

Settlement Principles

Embedded Generators

10 a). Embedded Generator in an Embedded Distributor

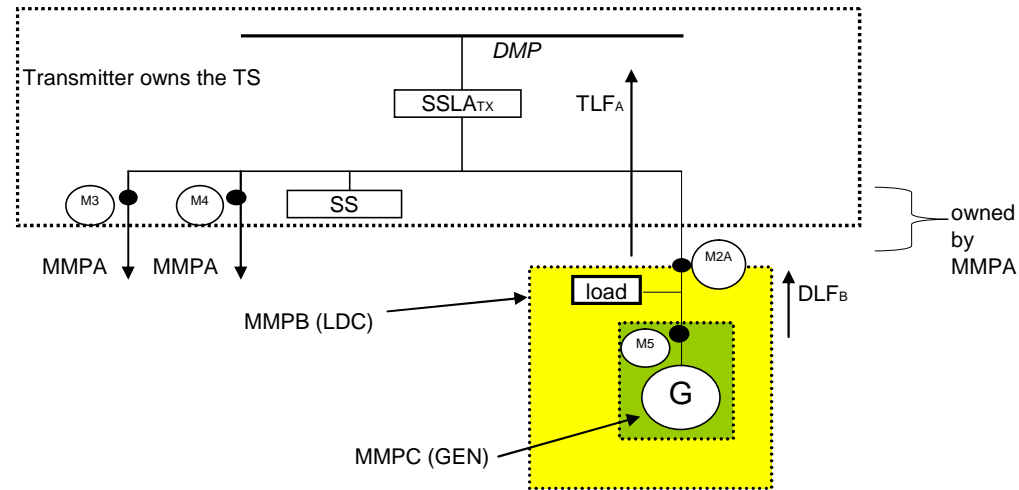

MMPA is directly connected
MMPA is the transmission customer
MMPB and MMPC are embedded

10 a)1. No agreement is required

MMPA _{Energy} =	M3+M4+SS+SSLAY	
MMPA _{TT} =	Check the appropriate transmission rate schedule for details	
MMPB _{Energy} =	M2A.TLF _A - (M5C12.(DLF _B .TLF _A) + M5C34.LF)	see note 3.
MMPC _{Energy} =	M5 _{1,2} .(DLF _B .TLF _A) delivered channels 1 & 2 = M5C12.(DLF _B .TLF _A) M5 _{3,4} . LF. (for received channels 3 & 4) = M5C34.LF = M5C12.(DLF _B .TLF _A) + M5C34.LF	see note 2.

- Note: 1. The embedded generator is an energy market participant
2. A loss factor (LF) default value of 1.0 will be used where not specified and agreed to by all parties
3. M5C12 and M5C34 are direction dependent
4. MMPA provides the loss calculations
5. MMPA responsible for station service metering
6. If the Generator output is higher than the Load MMPA should install feeder metering or agree with MMPB upon a correction factor (see example 10.b - LF1) to be applied to M2AC_{3,4}
The IESO will reject any correction factor that harms the Market.

Example of transmission tariff settlement:

Using HydroOne transmission rate schedule and assuming a new generator > 1 MW

MMPA_{TT network} = M3+M4+SS+SSLAY + M2A.TLF_A

MMPA_{TT connection} = M3+M4+SS+SSLAY + M2A.TLF_A + M5C34.LF

10 b). Embedded Generator in an Embedded Distributor

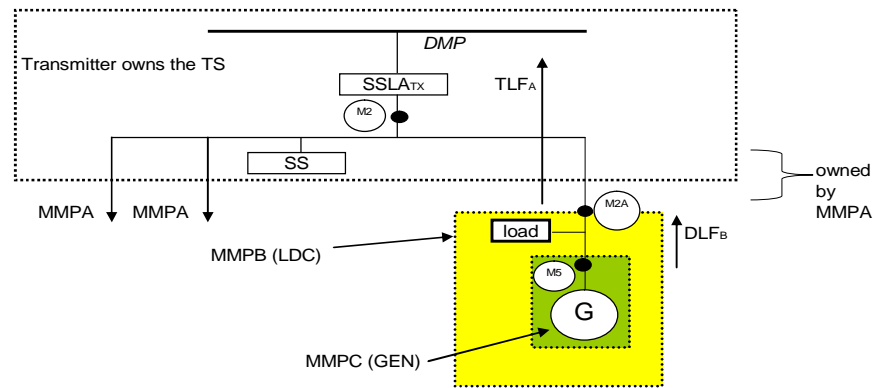

MMPA is directly connected
MMPA is the transmission customer
MMPB and MMPC are embedded

10 b)1. No agreement between MMPA and MMPB is required if:

In normal operating state the "load" is higher than the "generator" output.
M2A has constantly non-ZERO readings on Ch#1, ZERO on Ch#3.

An agreement is required between MMPB and MMPC

see note 2.

MMPA _{energy} =	M2+SSLA - M2A.TLFA	
MMPA _{TT} =	Check the appropriate transmission rate schedule for details	
MMPB _{energy} =	M2A.TLFA - (M5C12.(DLF _B .TLFA) + M5C34.LF)	see note 4.
MMPC _{energy} =	M5 _{1,2} .(DLF _B .TLFA) delivered channels 1 & 2 = M5C12.(DLF _B .TLFA)	
	M5 _{3,4} . LF. (for received channels 3 & 4) = M5C34.LF	see note 2.
	= M5C12.(DLF _B .TLFA) + M5C34.LF	

10 b)2. An agreement between MMPA and MMPB is required if:

In normal operating state the "generator" output is higher than the "load".
M2A has constantly ZERO readings on Ch#1, non-ZERO on Ch#3.

An agreement is required between MMPB and MMPC

see note 3.

MMPA _{energy} =	M2+SSLA - (M2AC12.TLFA + M2AC34.LF1)	see note 3.
MMPA _{TT} =	Check the appropriate transmission rate schedule for details	
MMPB _{energy} =	M2A _{1,2} .TLFA delivered channels 1 & 2 = M2AC12.TLFA	
	M2A _{3,4} . LF. (for received channels 3 & 4) = M2AC34.LF1	see note 3.
	=(M2AC12.TLFA + M2AC34.LF1) - (M5C12.(DLF _B .TLFA) + M5C34.LF)	see note 4.
MMPC _{energy} =	M5 _{1,2} .(DLF _B .TLFA) delivered channels 1 & 2 = M5C12.(DLF _B .TLFA)	
	M5 _{3,4} . LF. (for received channels 3 & 4) = M5C34.LF	see note 2.
	= M5C12.(DLF _B .TLFA) + M5C34.LF	

- Note: 1. The embedded generator is an energy market participant
2. A loss factor (LF) default value of 1.0 will be used where not specified and agreed to by all parties
3. If no agreement the equations are identical with 10 b)1. -> The loss factor LF1 = TLFA
4. M5C12 and M5C34 are direction dependent
5. MMPA provides the loss calculations
6. MMPA responsible for station service metering

Example of transmission tariff settlement:

Using HydroOne transmission rate schedule and assuming a new generator > 1 MW

MMPA_{TT} network = M2+SSLA

MMPA_{TT} connection = M2+SSLA+ M5C34.LF