

STANDARDS



---

# Site-Specific Loss Adjustments

## Requirements for Adjustment of Meter Readings for Site-Specific Losses in the IMO-Administered Market

---

Issue 3.0

This standard provides the principles, accountabilities, and requirements for *metering installations* used for *settlement* in the IMO-administered wholesale market.

## Disclaimer

The posting of documents on this Web site is done for the convenience of *market participants* and other interested visitors to the *IMO* Web site. Please be advised that, while the *IMO* attempts to have all posted documents conform to the original, changes can result from the original, including changes resulting from the programs used to format the documents for posting on the Web site as well as from the programs used by the viewer to download and read the documents. The *IMO* makes no representation or warranty, express or implied, that the documents on this Web site are exact reproductions of the original documents listed. In addition, the documents and information posted on this Web site are subject to change. The *IMO* may revise, withdraw or make final these materials at any time at its sole discretion without further notice. It is solely your responsibility to ensure that you are using up-to-date documents and information.

This document may contain a summary of a particular *market rule*. Where provided, the summary has been used because of the length of the *market rule* itself. The reader should be aware, however, that where a *market rule* is applicable, the obligation that needs to be met is as stated in the “*Market Rules*”. To the extent of any discrepancy or inconsistency between the provisions of a particular *market rule* and the summary, the provision of the *market rule* shall govern.

<b>Document ID</b>	MDP_STD_0005
<b>Document Name</b>	Site-Specific Loss Adjustments
<b>Issue</b>	Issue 3.0
<b>Reason for Issue</b>	Revised for Baseline 15.0
<b>Effective Date</b>	March 8, 2006

## Document Change History

Issue	Reason for Issue	Date
1.0	Issue for IMO Board Approval	December 3, 1999
2.0	Prepare for Baseline 11.1	June 2, 2004
3.0	Revised for Baseline 15.0	March 8, 2006

## Related Documents

Document ID	Document Title
MDP_PRO_0011	Market Manual 3: Metering Part 3.5: Site-Specific Loss Adjustments



# Table of Contents

---

**Table of Contents** ..... **iii**

**List of Figures** ..... **iii**

**List of Tables** ..... **iii**

**Table of Changes** ..... **iii**

**1. Introduction**..... **3**

    1.1 Purpose..... 3

    1.2 Scope..... 3

    1.3 Who Should Use This Document ..... 3

    1.4 Conventions ..... 3

**2. Accountability for Loss Adjustments** ..... **3**

**3. Documentation of Loss Adjustments** ..... **3**

**4. Basis for Calculation of Loss Adjustments**..... **3**

    4.1 Overview ..... 3

    4.2 Standard Loss Models ..... 3

    4.3 Loss Analysis ..... 3

    4.4 Radial Line Loss ..... 3

        4.4.1 Voltage-Dependent Loss ..... 3

        4.4.2 Current-Dependent Power Loss..... 3

        4.4.3 Other Loss ..... 3

    4.5 Transformer Loss..... 3

        4.5.1 Voltage-Dependent Power Loss ..... 3

        4.5.2 Other Loss ..... 3

    4.6 Method 1 ..... 3

    4.7 Method 2 ..... 3

**5. Data Required by Loss Models**..... **3**

    5.1 Voltage and Current Interval Data for Method 1 ..... 3

    5.2 Standardized Assumptions for Power Transformer..... 3

    5.3 Incomplete Metering Data ..... 3

**6. Development of Loss Adjustment Parameters** ..... **3**

6.1	Radial Lines.....	3
6.1.1	Radial Overhead Line.....	3
6.1.2	Radial Cable.....	3
6.1.3	Incomplete Line Data.....	3
6.2	Power Transformers.....	3
6.2.1	Factory Test Results.....	3
6.2.2	Incomplete Transformer Information.....	3
6.2.3	Factory Test Results of 'Equivalent' power transformers.....	3
<b>7.</b>	<b>Standard Loss Model – Example 1 .....</b>	<b>3</b>
7.1	Single-Power Transformer and Radial Line.....	3
7.2	Load Loss.....	3
7.3	No-Load Loss.....	3
7.3.1	Calculation of No-Load Losses.....	3
<b>8.</b>	<b>DESN Station – Example 2 .....</b>	<b>3</b>
<b>9.</b>	<b>Using Method 2 – Example 3.....</b>	<b>3</b>
<b>10.</b>	<b>Glossary of Terms.....</b>	<b>3</b>
<b>11.</b>	<b>References.....</b>	<b>3</b>
	<b>Appendix A: Calculation of Losses – Method 1 .....</b>	<b>A–3</b>
	<b>Appendix B: Application of Method 2.....</b>	<b>B–3</b>
	<b>References .....</b>	<b>3</b>

# List of Figures

---

Figure 4.1: Site-Specific Loss Adjustments .....	3
Figure 4.2: Per phase equivalent circuit .....	3
Figure 4.1: Standard Loss model - Method 1 .....	3
Figure 4.2: Loss Model for Method 2.....	3
Figure 7.1: Radial transmission line and power transformer installation .....	3
Figure 9.1: Three-winding (“Bermondsey”) power transformer .....	3
Figure 9.2: Losses calculated at each load point.....	3
Figure A.1: Calculation of losses in the transformer and line by Method 1.....	A-3
Figure A.2: Calculation of losses in the transformer and line.....	A-3
Figure A.3: Calculation of losses in the transformer and line (continued) .....	A-3
Figure A.4: Calculation of losses in the transformer and line (continued) .....	A-3
Figure A.5: Calculation of losses in the transformer and line for two-element metering by Method 1 .....	A-3
Figure B.1: Application of Method 2 to a three-winding power transformer.....	B-3
Figure B.2: Application of Method 2 to a three-winding power transformer (continued) .....	B-3
Figure B.3: Application of Method 2 to a three-winding power transformer (continued) .....	B-3

# List of Tables

---

None

# Table of Changes

Reference (Section and Paragraph)	Description of Change
Figure 8.1	Created new drawing image to replace image missing from previous version of document.
Section 8.	Corrected minor typographical error.



# 1. Introduction

---

## 1.1 Purpose

The *Market Rules* require *revenue meters* to be located as close as practicable to the defined point of sale. If the actual *meter point* is not located at the defined point of sale, the *Market Rules* require loss adjustments to be applied to the *meter* readings. The adjusted readings are equivalent to those that would have been obtained if the metering were at the defined point of sale.

This document provides the standards required to ensure equitable treatment of all *metered market participants*.

## 1.2 Scope

This procedure applies to all wholesale *meter* installations in the *IMO*-administered market where the actual *meter point* is not located at the *defined meter point*.

Site-specific loss adjustments can be made for power transformers and radial lines only. The methods described here cannot be used to adjust metering for network losses.

## 1.3 Who Should Use This Document

This document is intended for Professional Engineers preparing loss adjustment parameters for submission to the *IMO*.

## 1.4 Conventions

The following conventions are used throughout this document:

- a) The word “shall” denotes a mandatory requirement.
- b) *Italics* is used to indicate titles of acts or publications.

– End of Section –



## 2. Accountability for Loss Adjustments

---

The *metered market participant* is accountable for providing valid and accurate parameters for the site-specific loss adjustment models.

The *IMO* is accountable for:

- a) defining standard loss-adjustment models;
- b) defining the format for submission of parameters by the *metered market participant*;
- c) adjusting *metering data* for site-specific losses.

– End of Section –



## 3. Documentation of Loss Adjustments

---

The *IMO* provides separate loss models for lines and transformers. Often, assumptions must be made to calculate a set of parameters to be used for loss adjustment. These assumptions shall be documented and submitted to the *IMO* at the time of registration into the *metering registry*.

A registered professional engineer shall stamp the supporting documentation and the final loss adjustment parameters before submission to the *IMO*.

– End of Section –



# 4. Basis for Calculation of Loss Adjustments

## 4.1 Overview

Loss adjustments fall into two general categories. Site-specific loss adjustments are required because the actual *meter point* is not located at the *defined meter point*. If a participant is embedded within a distribution company, an additional adjustment is required to account for distribution losses as illustrated in the figure below:

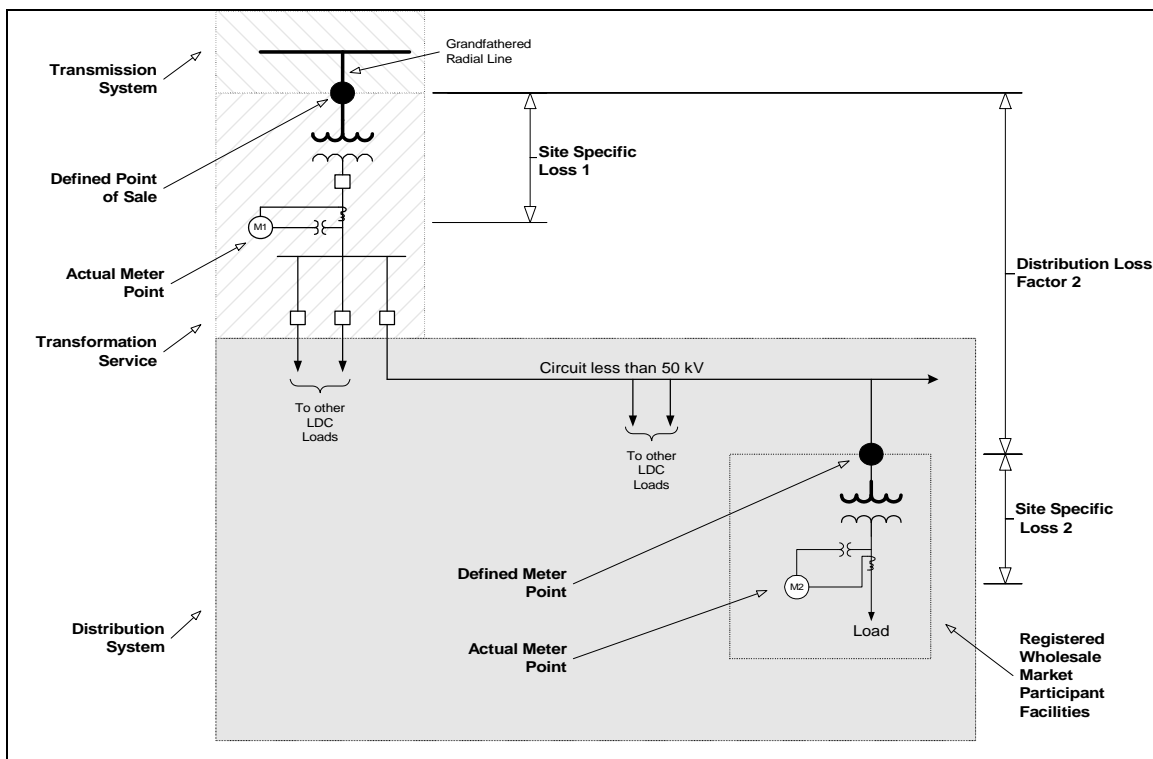

Figure 4.1: Site-Specific Loss Adjustments

## 4.2 Standard Loss Models

The Independent Electricity Market Operator (*IMO*) provides two loss-adjustment models. The first model, called Method 1, uses amp-squared-hour and volt-squared-hour data measured by the *meter* to calculate losses in each interval.

Method 1 shall be applied in all cases, except as approved by the *IMO*. Method 1 produces correct loss adjustments even when load changes rapidly during the metered interval. Development of coefficients is simpler using Method 1 and fewer assumptions are required.

Method 1 also has the advantage that line and transformer losses may be separately identified. It can be applied in any situation where the power transformer has two windings.

Method 2 analyzes the losses over a range of operating conditions, recording the losses for each. It then uses numerical curve fitting to determine a second order polynomial relationship between the apparent power measured by the *meter* and the loss in each interval. Examples where Method 2 may be applied include transformation *facilities* that have three-winding power transformers, radial untapped four-wire circuits, and untapped single-phase laterals.

Method 2 uses average interval *demand* to estimate losses. It produces loss estimates slightly lower than those of Method 1 when load is not constant during the *settlement* interval. For this reason, Method 2 is limited to those situations in which the nature of the equipment physically prevents the installation of the metering required to apply Method 1. Conservative assumptions shall be made in the engineering analysis to ensure that the *metered market participant* receives no long-term benefit through the application of Method 2.

The assumptions of Sections 4.2, 4.3 and 4.4 shall apply to all loss calculations submitted to the *IMO*. These loss models are based on the equivalent circuit of figure 4.2 illustrated below:

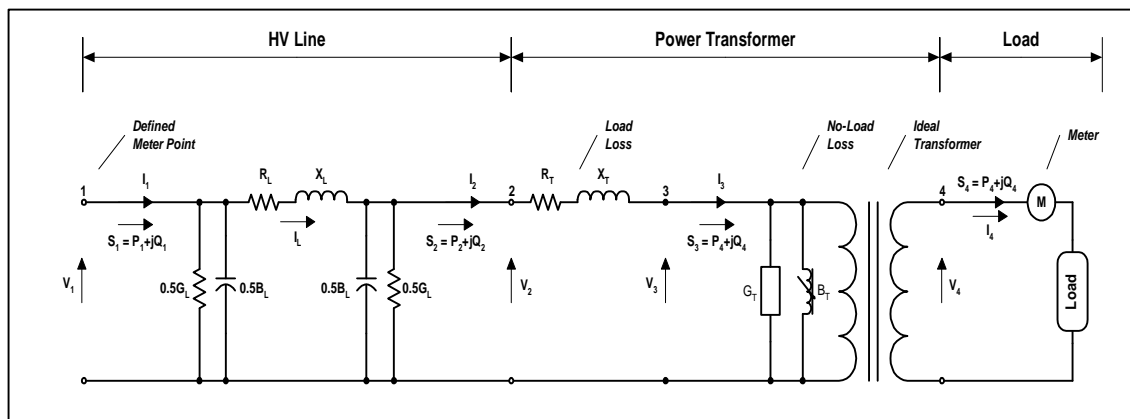

**Figure 4.2: Per phase equivalent circuit**

### 4.3 Loss Analysis

The active and reactive power losses in the transformer and radial line are determined at a reference power flow. This is normally the rated power flow for the power transformer. The active losses calculated at the reference power flow are then used to determine the constants of proportionality for the standard loss model (Method 1). If Method 2 is applied, several power flow studies shall be required under various conditions to determine the loss coefficients.

## 4.4 Radial Line Loss

### 4.4.1 Voltage-Dependent Loss

- a) Reactive power generated in the shunt capacitance of a radial line shall be assumed proportional to  $V^2$ .
- b) Dielectric loss, if any, shall be assumed to be proportional to  $V^2$ .

### 4.4.2 Current-Dependent Power Loss

- a) Both active and reactive power loss in the series portion of the line shall be assumed to be proportional to  $I^2$ .

### 4.4.3 Other Loss

- a) Corona loss shall normally be ignored.

## 4.5 Transformer Loss

### 4.5.1 Voltage-Dependent Power Loss

- a) The active power loss at no-load shall be assumed to be proportional to  $V^2$ .
- b) The reactive no-loss at no-load shall be assumed to be proportional to  $V^4$ .

### 4.5.2 Other Loss

- a) Both active and reactive loss in a series portion of the power transformer shall be assumed to be proportional to  $I^2$ .

## 4.6 Method 1

Many *metered market participants* want to separately identify losses in radial lines<sup>1</sup> and transformers. Physical losses depend on current and voltage. Method 1 uses engineering principles to convert measurements of current and voltage made by the *meter* into loss adjustments.

Voltage-dependent losses in lines and transformers are estimated differently. In a radial line, both active and reactive losses are proportional to the second power of voltage<sup>2</sup>.

In a transformer, an exact relationship between voltage and loss usually cannot be obtained. For this reason, active losses are assumed to be proportional to the second power of voltage, but reactive losses are assumed to be proportional to the fourth power of voltage.

---

<sup>1</sup> Note: The examples shown here assume the radial line has not been defined as part of the transmission system and those loss adjustments are in fact required. Contact the IMO to find out if such loss adjustments apply in your situation.

<sup>2</sup> Corona loss on radial lines is ignored at the present time by the IMO.

Where Method 1 is applied, losses will be calculated by the *IMO* for each interval using the loss model illustrated in the Figure 4.1 below. The active power loss is  $P_{Loss}$ . The reactive power loss  $Q_{Loss}$  is positive for lagging reactive power

$$\begin{aligned}
 P_{Tran} &= A(V2R + V2Y + V2B) + B(I2R + I2Y + I2B) \\
 Q_{Tran} &= C((V2R)^2 + (V2Y)^2 + (V2B)^2) + D(I2R + I2Y + I2B) \\
 P_{Line} &= E(V2R + V2Y + V2B) + F(I2R + I2Y + I2B) \\
 Q_{Line} &= G(V2R + V2Y + V2B) + H(I2R + I2Y + I2B)
 \end{aligned}$$

**Figure 4.1: Standard Loss model - Method 1**

The G coefficient (for  $Q_{Line}$ ) is negative. The losses in the radial line and power transformer are calculated separately from interval data recorded by the *meter*, where:

- $I2R$ ,  $I2Y$ , and  $I2B$  are the time integrals<sup>3</sup> of current squared ( $\int I^2 dt$ ) for each of the red, yellow, and blue phases. On a delta power system only R and B phases may exist.
- $V2R$ ,  $V2Y$ , and  $V2B$  are the time integrals of voltage squared ( $\int V^2 dt$ ) for each of the red, yellow, and blue phases. On a delta power system only R and B phases may exist.
- A, B, C, D, E, F, G, and H are constants of proportionality for current and voltage dependent losses. These may be determined as shown in Appendix A.

## 4.7 Method 2

Method 2 uses neither current nor voltage information<sup>4</sup>. Rather, losses are computed for each interval based on the active and reactive *energy* measured by the *meter*. The loss-adjustment equations take the form:

$$\begin{aligned}
 P_{loss} &= K_1 S_{Total}^2 + K_2 S_{Total} + K_3 \\
 Q_{loss} &= K_4 S_{Total}^2 + K_5 S_{Total} + K_6
 \end{aligned}$$

**Figure 4.2: Loss Model for Method 2**

In the equation:

- $P_{loss}$  is the combined active power loss in the radial line and three-winding transformer.
- $Q_{loss}$  is the combined reactive power loss in the radial line and three-winding transformer.
- $S_{Total}$  is the combined apparent power measured by the *meters* on the secondary and tertiary transformer windings.

On three-winding power transformers the division of load between the secondary and tertiary windings affects the loss-adjustment coefficients. Appropriate assumptions must be made regarding this split. When developing loss coefficients, the engineering analysis shall include the entire range of load splits observed over normal seasonal load cycles.

<sup>3</sup> This data will be available for each 5- or 15-minute interval and be recorded as if it were *energy* data.

<sup>4</sup> Even though these quantities are not used in loss calculations, the *IMO* requires them for data validation where metering, grandfathered into the market, cannot detect loss of current or voltage.

On four-wire circuits and single-phase laterals, losses in the neutral wire shall be accounted for. The maximum range of neutral currents expected over normal seasonal cycles shall be included when the loss coefficients are developed.

Establishing loss adjustment coefficients under Method 2 requires:

- a) establishing a one-line diagram and the electrical properties of the power transformers and radial line;
- b) establishing the full range of load sharing possibilities between windings, neutral current, power factor, upstream system voltage, and ULTC tap position that may be reasonably expected over the life cycle of the installation;
- c) using load-flow software to calculate the losses at several points over the range of each variable;
- d) graphing the losses as a function of the *demand* that would be observed by the metering;
- e) using numerical curve fitting software to determine the coefficients of the second order polynomial function to be used by the *IMO* to estimate losses;
- f) using the curve fitting software to determine a measurement of the quality of the resulting predictions ( $R^2$ ).

Values of  $R^2$  equal to or exceeding 0.90 provide reliable loss estimates. If the situation varies so widely that  $R^2$  is less than 0.80, a fixed percentage factor representing the worst-case loss adjustment shall be provided to the *IMO*.

– End of Section –



## 5. Data Required by Loss Models

---

### 5.1 Voltage and Current Interval Data for Method 1

The standard loss model used by the *IMO* assumes that loss can be calculated from three types of proportionality. Losses in the series portion of a line or transformer are proportional to the time integral of the square of the current. Commercially available *revenue meters* record this quantity in three data tracks, one for each current. Commonly called I2, I2H, or I<sup>2</sup> in the documentation, the measured quantity is  $\int I^2 dt$  over a 5- or 15-minute interval.

Multiplying the I2H interval data per phase by the resistance per phase results in the active power loss in the series components. Similarly, multiplying the I2H interval data by the reactance per phase results in the reactive loss in the series portion of the system being modeled. Summing the results over all three phases results in the total active and reactive loss. Because series power system impedance is almost always nearly balanced, the same result can be obtained by summing the I2H per phase and multiplying by the positive sequence impedance.

Losses in the shunt portions of the radial line, and some portions of the power transformer, are proportional to the time integral of the voltage squared. *Meter* manufacturers refer to this as V2, V2H, or V<sup>2</sup> in their documentation; however, the measured quantity is  $\int V^2 dt$ . The charging *energy* for a radial line is proportional to V2H as are the dielectric losses.

The active no-load loss of a power transformer is assumed to be proportional to V<sup>2</sup> and the reactive no-load loss is assumed to be proportional to V<sup>4</sup>.

### 5.2 Standardized Assumptions for Power Transformer

The active no-load loss in the power transformer is assumed to vary as the square of voltage. Also, the reactive power loss in the transformer at no-load is assumed to be proportional to V<sup>4</sup>.

For most transformers, the information needed to determine the actual no-load loss, as function of voltage, was not recorded during factory testing.

However a few transformers do have the required data. For these transformers, the no-load loss is observed to be proportional to V<sup>K</sup>. The K coefficient is constant for any particular power transformer but may vary from 1.5 to 4 for active no-load loss and 2 to 16 for reactive no-load loss in different units.

Because exact information is lacking on most transformers, North American industry has standardized the assumption that K = 2 for active no-load losses and K = 4 for reactive no-load losses. All *metered market participants* are treated equally by this rule; however, a small cross subsidy exists from those with *energy* efficient transformers to those with higher loss equipment.

On balance, the dollar value of this error is small compared to the value of the commodity actually traded. For this reason, the *IMO* has adopted the North American pattern but reserves the right to re-evaluate this assumption in future years.

### 5.3 Incomplete Metering Data

If the *meter* does not record  $V^2$  or  $I^2$ , or if it is unavailable owing to equipment failure, the *IMO* will assume a voltage and then calculate the average current from the active and reactive interval power recorded by the *meter*. Squaring this average current and multiplying by appropriate constants results in the loss adjustment.

If the *meter* does not record reactive power, the *IMO* may also assume a power factor before calculating the average current. In this case the *IMO* may assume a power factor either at the lower quartile of values observed or the lower limit allowed by power system controls and protections.

The assumed voltage, raised to the appropriate power, will be used to calculate the voltage-dependent losses using the appropriate constants.

– End of Section –

## 6. Development of Loss Adjustment Parameters

---

As discussed above, the *metering data* can be used to calculate losses based on actual power system conditions. In Method 1, the losses are combined into groups that are voltage dependent and current dependent. Each grouping results in four constant parameters, two for active power and two for reactive power in each component. Method 2 uses two polynomial functions to estimate interval losses based on total MVA *demand* in the interval.

Engineering analysis establishes the coefficients required for either of these methods. The analysis shall be included in the *meter point* documentation.

Sections 6.1 and 6.2, below, describe the factors to be included in the engineering analysis when loss adjustment parameters are prepared.

### 6.1 Radial Lines

In its final report the Ontario Market Design Committee recommended that existing transmission connections be grandfathered. As a result, some existing radial lines may be deemed to be part of the *IMO-controlled grid* while others may not.

If a radial line is deemed part of the *transmission system* by the *IMO*, no adjustment for loss is required.

If the line is not deemed part of the *IMO-controlled grid* the factors listed below must be included in the preparation of loss-adjustment parameters.

Impedance calculations shall be based on:

- a) George, J. Anders. *Rating of Electric Power Cables*. New York: IEEE Press, c1997.
- b) IEC Standard 287. Calculation of Continuous Rating of Cables (100% Load Factor), c1982.
- c) IEEE Standard 738. Standard for Calculating the Current-Temperature Relationship of Bare Overhead Conductors, c1993.
- d) Central Station Engineers. *Electrical Transmission and Distribution Reference Book*, Westinghouse Electric Corp., East Pittsburgh, PA, c1950. Available from ABB Power Systems Inc.
- e) Electrical Utility Engineers. *Electrical Utility Engineering Reference Book: Distribution Systems*, Westinghouse Electric Corp., East Pittsburgh, PA, c1959. Available from ABB Power Systems Inc.
- f) Blackburn, J. Lewis. *Symmetrical Components for Power System Engineering*. New York: Marcel Dekker Inc, c1993.
- g) *Aluminum Electrical Handbook* published by the Aluminum Association.
- h) Standard tables published by the IPCEA.

The basis for calculation of electrical losses on radial lines shall be:

– End of Section –

### 6.1.1 Radial Overhead Line

- a) Positive sequence series resistance at 50°C.
- b) Positive sequence series reactance.
- c) Positive sequence shunt reactance.
- d) If the nominal voltage is 161 kV or higher: dielectric loss at average operating voltage.
- e) Corona loss may be ignored.
- f) If the effect of harmonics exceeds 5% of the total loss at fundamental frequency, the effect shall be included.
- g) If the line exceeds 160 km in length, the  $R_L$ ,  $X_L$ ,  $G_L$ , and  $B_L$  shall be adjusted using the standard long-line model developed in section 6.7 of Grainger, John J. and Stevenson W. D. *Power System Analysis*. New York: McGraw-Hill Inc., c1994.

### 6.1.2 Radial Cable

- a) Positive sequence series resistance at ambient temperature plus one third of the maximum design temperature rise above ambient.
- b) Positive sequence series reactance.
- c) Positive sequence shunt reactance.
- d) Active and reactive loss in screens, sheaths, armour, and pipes.
- e) Dielectric loss at average operating voltage where nominal voltage equals or exceeds the value stated for the insulating material in the Anders or IEC references cited above.
- f) If the effect of harmonics exceeds 5% of the total loss at fundamental frequency, the effect shall be included.
- g) If the line exceeds 40 km in length, the  $R_L$ ,  $X_L$ ,  $G_L$ , and  $B_L$  shall be adjusted using the standard long-line model as shown in section 6.7 of Grainger, John J. and Stevenson W. D. *Power System Analysis*. New York: McGraw-Hill Inc., c1994.

### 6.1.3 Incomplete Line Data

If conductor size, conductor spacing, line length, or other necessary details are unavailable:

- a) The conductor shall be assumed to be the smallest size that would carry the rated load of the connected power transformers at a conductor temperature of 50°C.
- b) The conductor shall be assumed to be ASCR.
- c) Conductor spacing shall be estimated from field observations.
- d) Line section length shall be measured in the field or estimated from geographic maps.

– End of Section –

## 6.2 Power Transformers

### 6.2.1 Factory Test Results

The following factors shall be the basis for development of loss adjustment parameters for power transformers:

- a) factory test results corrected to 75°C;
- b) actual position of fixed taps;
- c) the most frequently occurring variable tap position, if fitted with an under load tap changer;
- d) linear interpolation shall be used when actual tap positions are intermediate to factory test results;
- e) average voltage in the vicinity of the installation.

The following data is required from the factory test results:

- a) percentage exciting current at rated voltage;
- b) percentage impedance at self-cooled rating;
- c) active and reactive no-load loss;
- d) active and reactive load loss.

### 6.2.2 Incomplete Transformer Information

If factory test results are unavailable, the transformer shall be assumed to be at the lower quartile of its class.

If general information on the class is unavailable, or if the class cannot be determined, the following assumptions shall be made:

- a) Active no-load loss shall be assumed to be 0.3%.
- b) Active load loss shall be assumed to be 0.7%.
- c) The exciting current at rated voltage shall be assumed to be 1.5%.

The assumptions result in a 1.0% active power loss at nameplate rating.

### 6.2.3 Factory Test Results of 'Equivalent' power transformers

If factory test results for a power transformer are unavailable, the *IMO* may authorize instead the use of test results of an 'equivalent' power transformer

Proof of equivalency shall be provided in the form of verifiable nameplate data, where the nameplate contains the required information and is affixed to the power transformers.

Two or more transformers are deemed 'equivalent' for the purpose of this Standard if the following information and parameters, are the same for both or all transformers:

1. Manufacturer
2. Same vintage /years of construction
3. Type / design
4. Apparent Power rating(s) - kVA or MVA
5. Number of windings and voltages - kV phase to phase
6. Impedance(s) on short circuit test\* - Percent of rated voltage

The sequence of serial numbers stamped by the manufacturer on the nameplate will also be considered in establishing equivalency.

\* Where all other parameters are the same, it is possible that impedance values of several transformers will vary within a range of 1%. In such cases, all 'equivalent' transformers for which test results are unavailable will be deemed to have the impedance that yields the highest losses.

**– End of Section –**

# 7. Standard Loss Model – Example 1

## 7.1 Single-Power Transformer and Radial Line

The figure below illustrates a radial transmission line and power transformer installation. The radial line is privately owned and built after the market opening in 2000. The *Market Rules* require that the losses on the radial line and power transformer be included in the *meter* readings.

Because the line is operated at less than 161 kV, dielectric loss may be neglected.

Transformer losses are based on factory test results obtained at nominal voltage and rated current, interpolated to the actual HV tap on which the transformer was placed in service.

If the line were deemed to be part of the *transmission system*, the losses on it would be ignored

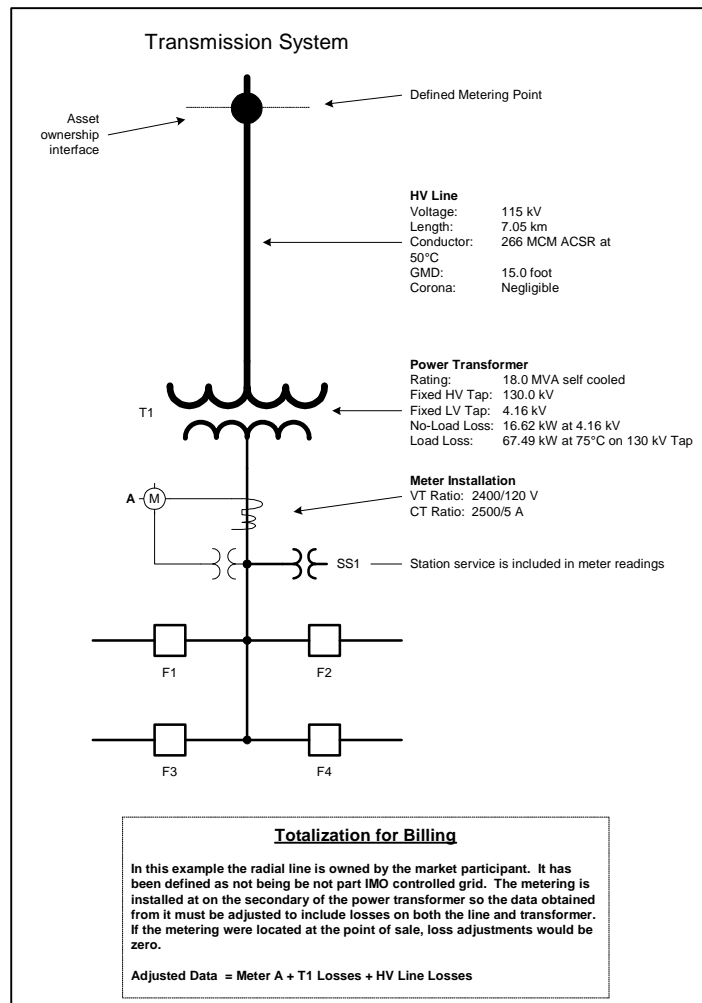

Figure 7.1: Radial transmission line and power transformer installation

Transformer losses are calculated based on the following field installation and factory test data:

<b>Transformer Data</b>		
<b>Item</b>	<b>Value</b>	<b>Unit</b>
Actual HV Tap	130.0	kV
Actual LV Tap	4.16	kV
Self Cooled Rating ( $S_{Rated}$ )	18.0	MVA
No-load Loss at 130 kV	16.62	kW
No-load Exiting Current at 130 kV ( $I_{ex}$ )	0.225	%
Load Loss at 18.0 MVA and 75°C	67.49	kW
Percent Impedance at 18.0 MVA and 75°C	9.32	%

As shown in Appendix A, when the transformer delivers rated power and rated voltage to the secondary bushings, the high-voltage bushings carry  $S_2$  MVA at  $V_2$  kV. These values are the receiving-end quantities for the radial line. The sending-end quantities are calculated based on the following field installation data and standard conductor tables:

<b>Radial Line Data</b>		
<b>Item</b>	<b>Value</b>	<b>Unit</b>
Nominal Voltage	115	kV
Length (L)	7.05	km
Conductor	266 ASCR	MCM
Geometric Mean Distance (d)	15.00	Feet
Positive sequence resistance per unit length at 50°C ( $r_a$ )	0.2392	Ohm/km
Positive sequence self-reactance per unit length ( $x_a$ )	0.2889	Ohm/km
Positive sequence mutual reactance per unit length ( $x_d$ )	0.2042	Ohm/km
Positive sequence self-capacitive reactance ( $x'_a$ )	0.1728	Megohm.km
Positive sequence mutual capacitive reactance ( $x'_d$ )	0.1292	Megohm.km
Positive sequence resistance ( $R_1 = r_a L$ )	1.6864	Ohm
Positive sequence reactance ( $X_1 = (x_a + x_d) L$ )	3.476	Ohm
Positive sequence shunt reactance ( $X'_1 = (x'_a + x'_d) / L$ )	42,847	Ohm

## 7.2 Load Loss

Some of the losses in the transformer and line are directly proportional to the square of the series current. Using the notation of Figure 4.2 above, the current-dependent losses occur in  $R_L$ ,  $X_L$ ,  $R_T$ , and  $X_T$ . Appendix A shows that these total 33.27 kW and 584.4 kVAR per phase.

If the *meter* installed records  $\int I^2 dt$  for each metered interval, that value, scaled by the appropriate factor, shall be used by the *settlement* system to calculate the losses using the A, B, C, D, and E coefficients.

If the *meter* does not record  $I^2 H^5$ , the *IMO* shall assume a voltage that is low to average for the vicinity in which the transformer is installed. The average current during the interval would then be calculated from the active and reactive power recorded by the *meter* and the assumed voltage. The *IMO* shall monitor the voltage ported during the on-site testing required by *market rule* 1.0 (Chapter 6, Appendix 6.3) and shall occasionally adjust the assumed voltage.

If the *meter* does not record reactive power, the *IMO* shall assume a power factor in the low to average range observed during *meter* testing carried out during the on-site test results reported by the *metering service provider*, as required by the *Market Rules* Chapter 6, Appendix 6.3.

## 7.3 No-Load Loss

### 7.3.1 Calculation of No-Load Losses

Some losses are directly proportional to the square of the voltage owing to the line charging current and the no-load loss in the power transformer. These occur in the shunt admittance  $G_L$ ,  $B_L$ , and  $G_T$ .

If the *meter* installed records  $\int V^2 dt$  for each billing interval, that value, scaled by the appropriate factor, shall be used by the *settlement* system to calculate the losses based on the A, B, C, D, and E coefficients.

If the *meter* does not record  $V^2 H^6$ , the *IMO* shall assume a voltage that is average to high in the range of values observed on-site, and reported by the *metering service provider* carrying out the on-site testing required by *market rule* 1.0 (Chapter 6, Appendix 6.3). The *IMO* may occasionally adjust the assumed voltage based on the observed values.

The reactive power loss in the transformer is assumed to be proportional to  $V^4$ . The transformer in the example would be modeled as having a no-load reactive power loss of 12.31 kVAR.

– End of Section –

<sup>5</sup> Most meter manufacturers refer to  $\int I^2 dt$  interval data as I2 or I2H in their documentation.

<sup>6</sup> Most meter manufacturers refer to  $\int V^2 dt$  interval data as V2 or V2H in their documentation.



# 8. DESN Station – Example 2

The following figure illustrates a transformer station supplying three distribution companies.

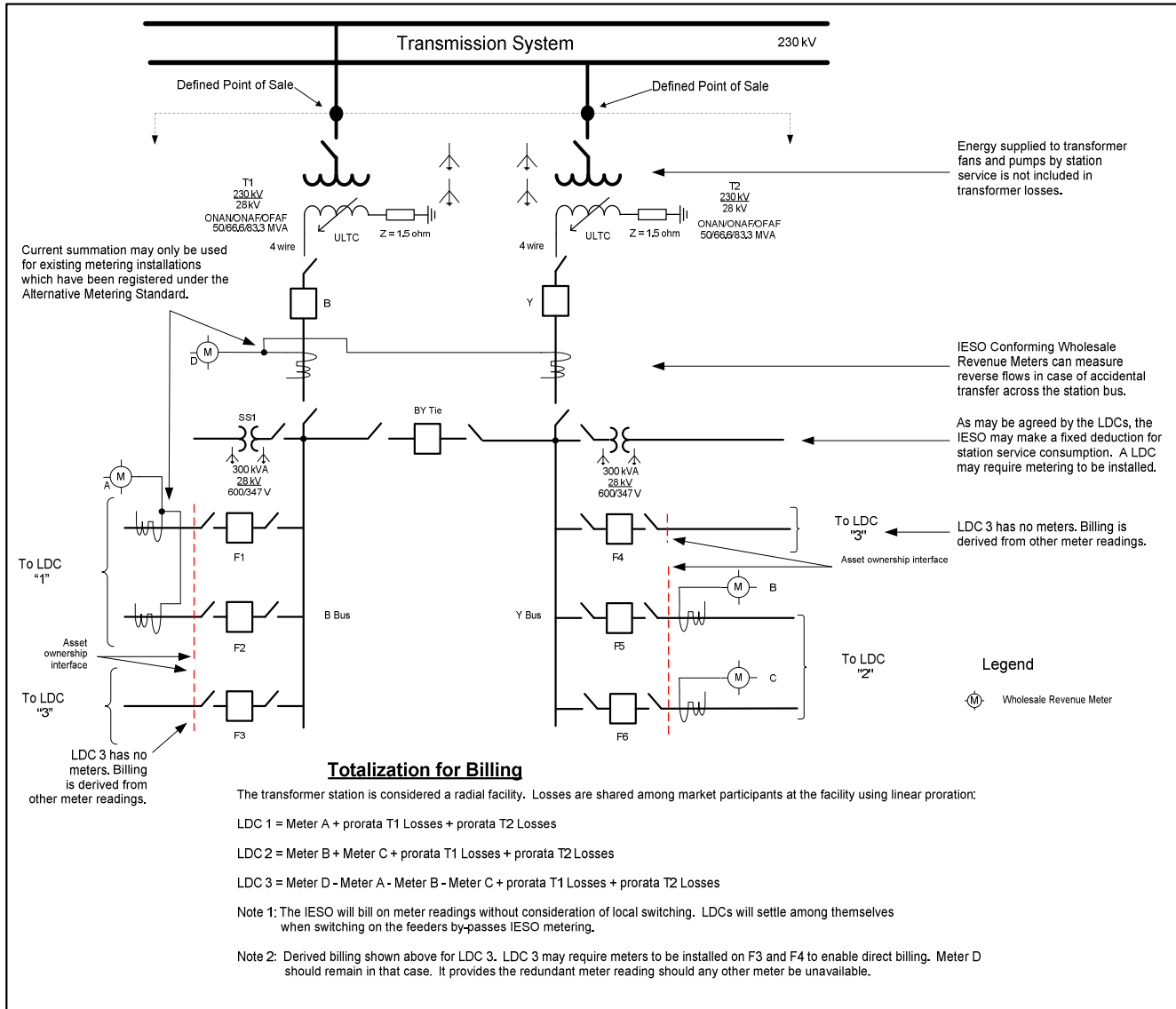

**Figure 8.1: Supply to three distribution companies**

A single *meter*, D, records the total consumption at the station. Two of the distribution companies have metering installed; the third derives from the difference between the station total and the other distribution companies.

The *IMO* shall settle the accounts of the three *metered market participants* using the *meters* as installed. Because consumption is calculated as a difference quantity, the *meter* readings for LDC3 include the *station service* consumption. If LDC3 does not own the transformation station it shall settle with the station owner on any mutually agreeable means.

The power transformers are fitted with fixed HV taps and voltage regulators on the secondary side. The transformer data required is in the same format as shown in Example 1 and the losses shall be calculated using the standard loss model.

If the transformers have:

- a) the same MVA ratings,
- b) nearly equal impedance, and
- c) the same HV and LV tap positions;

the coefficients for the standard loss model shall be calculated based on:

- a) The assumption that total load divides evenly between the two transformers.
- b) Factory test results, interpolated if the actual HV tap position is between positions tested in the factory.
- c) Factory test results, interpolated if the most frequently occurring LV tap position is intermediate between positions tested in the factory.
- d) Combined no-load losses.
- e) Combined load losses.

If the transformers are not similar, engineering analysis is required to establish the magnitude of the most frequently occurring circulating current, the individual loss in each power transformer, and the corresponding combined loss. This data would be used to determine the coefficients A through H for Method 1 or  $K_1$  through  $K_6$  for Method 2.

The interval data collected from *meter* D in the example would then be used by the *IMO* to calculate the combined loss in both power transformers.

If Method 1 is selected and the *meter* at D does not record  $V^2$ ,  $I^2$  or reactive power, the voltage and power factor will be assumed as described in Example 1.

The consumption of LDC3 is calculated as the difference between *meter* D and those of LDC 1 and LDC2.

- a) The *settlement* system shall maintain a virtual *meter* to record this data. Call this *meter* E.

Once the losses have been calculated, they shall be allocated to *meters* A, B, C, and E:

- b) Total losses allocated pro-rata based on apparent power (kVA *demand*), in each interval.
- c) If the total apparent power measured by the *meter* is zero and the transformer was energized throughout the interval, the voltage-dependent losses shall be divided equally between the *meters*.

– End of Section –

# 9. Using Method 2 – Example 3

Illustrated in the figure below is a three-winding (“Bermondsey”) power transformer. It has separately metered secondary and tertiary windings and is connected to the *transmission system* through a radial line operated at 230 kV. The self-cooled ratings of the windings are 50/30/20 MVA and the rated voltages are 230/44/27.6 kV. Because both secondary and tertiary windings supply the same municipality, the observed load share between them almost never varies from 1.5:1.

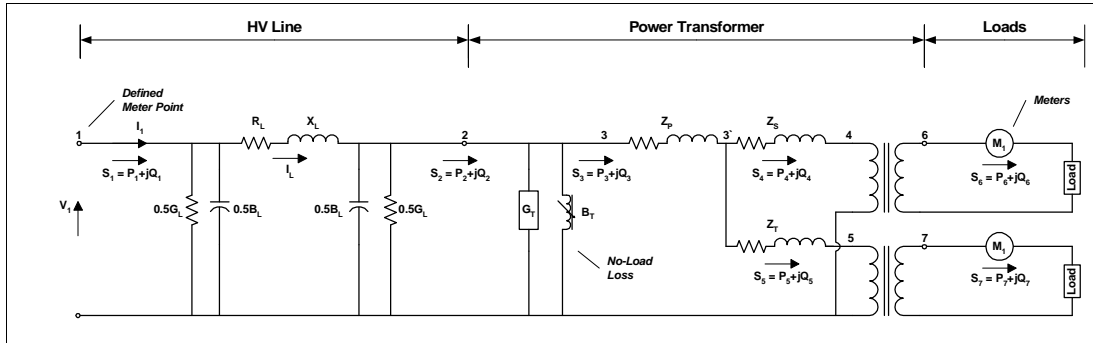
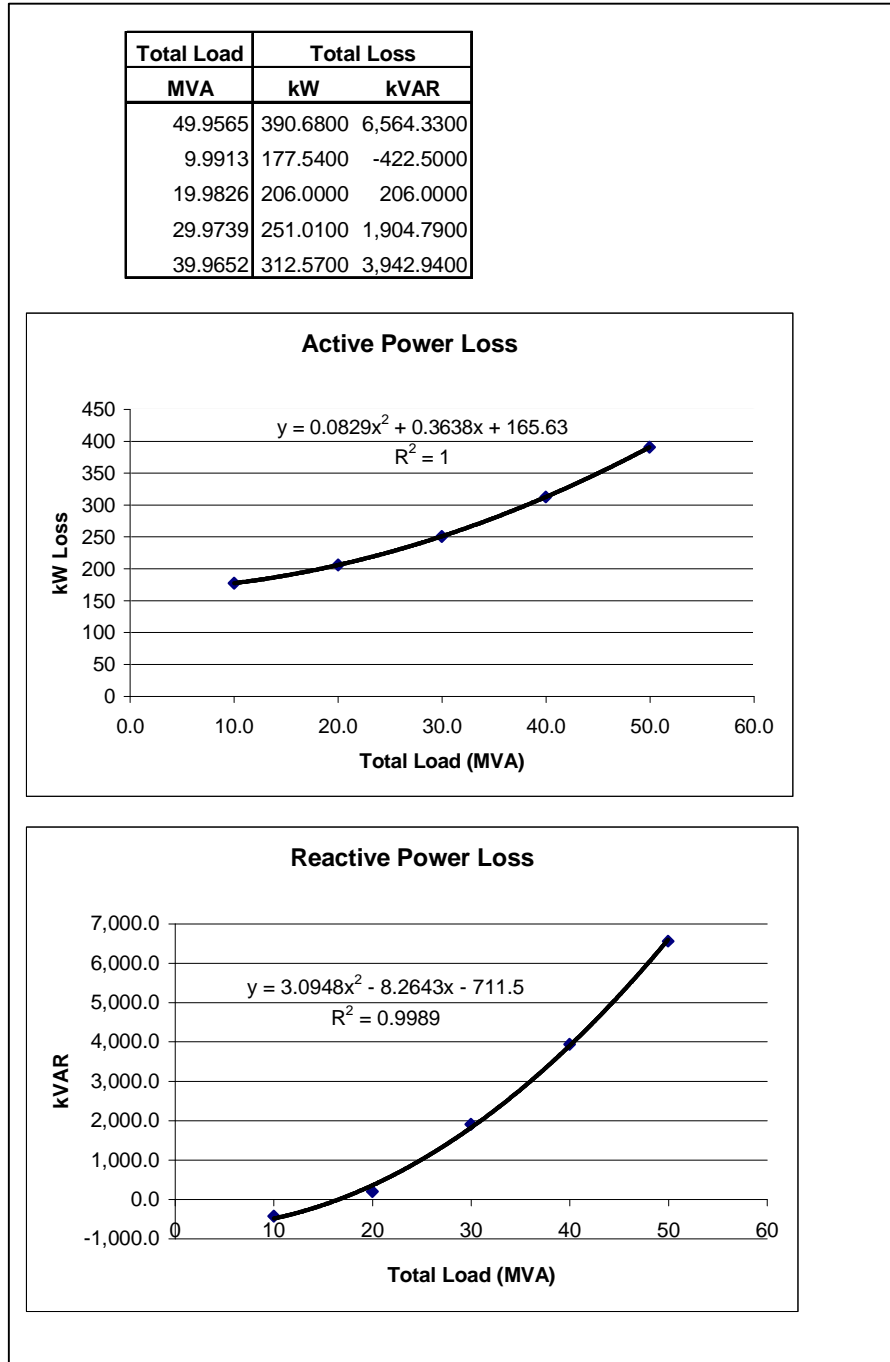

Figure 9.1: Three-winding (“Bermondsey”) power transformer

The figures below develop the required loss adjustment coefficients. In the figure below, a table showing the losses calculated at each load point is provided. The curves shown below indicate the resulting graph. Curve-fitting software was used to develop the K coefficients and the R<sup>2</sup> illustrated. Appendix B illustrates the calculations required to obtain these data points.



**Figure 9.2: Losses calculated at each load point**

– End of Section –

# 10. Glossary of Terms

---

The following terms were used in this standard:

**Actual meter point:** For loads, the physical location of the current transformers. For *generators* with the current transformers on the output side of the unit, the physical location of the current transformers. For *generators* with the current transformers on the grounded side of the unit, the output bushings of the *generator*.

**Alternate meter:** In a dual or partial redundant installation, one of the *meters* is arbitrarily designated alternate and will be used for validation of data from the main *meter*. Alternate data may be substituted when valid data from the main *meter* is unavailable. The term implies full compliance with the requirements of Measurement Canada.

**Check metering:** As defined in the *Market Rules*.

**Connection point:** As defined in the *Market Rules*.

**Current summation:** A method for deriving the combined power flow at two distinct *defined meter points*. A single main *meter* is supplied by the voltage transformers from one of the *meter points* and the paralleled secondaries of the current transformers at both *meter points*.

**Defined meter point:** A physical location either at the boundary of the *IMO-controlled grid*, or embedded within the *distribution system*, at which electrical quantities are either actually, or deemed to be, measured.

**Defined point of sale:** A physical location on the boundary of the *IMO-controlled grid* at which *settlement* transactions are deemed to take place.

**Instrument transformer:** As defined in the *Market Rules*.

**Main meter:** The only *meter* of a non-redundant location or the *meter* normally used for *settlement* in a redundant installation. In a dual or partial redundant installation, one of the *meters* is arbitrarily designated main and will be used for *settlement* unless valid data from it is unavailable, at which time data from the alternate *meter* may be substituted. The term implies both *meters* fully comply with the requirements of Measurement Canada.

**Meter installation:** As defined in the *Market Rules*.

**Meter point documentation:** A package of documents comprising a map or electrical one-line showing the location of the *defined meter point*, a totalization table and documentation supporting site-specific loss adjustment and error correction factors. Other information required in the package includes details needed for collection of data such as telephone number, password, and translation interface module (TIM). A copy of any analysis or power flow studies used to develop loss adjustments shall also be included. Other details required include, supply point details such as operating designation, voltage, *instrument transformer* ratios, multipliers, length of data storage and format, existence of redundant or check metering, names and telephone numbers to facilitate problem resolution.

**Meter point:** As defined in the *Market Rules*.

**Meter:** As defined in the *Market Rules*.

**Metered market participant:** As defined in the *Market Rules*.

**Metering maintenance:** Activities carried out to verify correct operation of the *meter* and *instrument transformers* installed at a *meter point*. Includes installation repairs, replacement and preparation of *meter point* documentation.

**Metering service provider:** As defined in the *Market Rules*.

**Metering register:** As defined in the *Market Rules*.

**Registered Wholesale Meter (RWM):** As defined in the *Market Rules*.

**Registration:** The entry of metering information into the *IMO* data collection system databases after comprehensive on-site and end-to-end testing to verify remote access to metered data and accurate replication of *meter* parameters and measured quantities at the *IMO*.

**Revenue metering:** As defined in the *Market Rules*.

**Site-specific loss adjustment:** If the actual *meter point* is not at the *defined meter point*, the *meter* readings shall be adjusted to account for the difference. Application of the loss adjustment results in the readings that would have been obtained if the *meter* had been installed at the *defined meter point*.

**Voltage transformer:** A device that scales down primary voltage supplied to a *meter* while providing electrical isolation.

**Wholesale metering:** All equipment installed to measure and record physical transactions at *defined meter point* in the *IMO* administered markets.

– End of Section –

# 11. References

---

1. George, J. Anders. *Rating of Electric Power Cables*. New York: IEEE Press, c1997.
2. IEC Standard 287. *Calculation of Continuous Rating of Cables (100% Load Factor)*, c1982.
3. IEEE Standard 738. *Standard for Calculating the Current-Temperature Relationship of Bare Overhead Conductors*, c1993.
4. Central Station Engineers. *Electrical Transmission and Distribution Reference Book*, Westinghouse Electric Corp., East Pittsburgh, PA, c1950. Available from ABB Power Systems Inc.
5. Electrical Utility Engineers. *Electrical Utility Engineering Reference Book: Distribution Systems*, Westinghouse Electric Corp., East Pittsburgh, PA, c1959. Available from ABB Power Systems Inc.
6. Blackburn, J. Lewis. *Symmetrical Components for Power System Engineering*. New York: Marcel Dekker Inc, c1993.
7. *Aluminum Electrical Handbook* published by the Aluminum Association.
8. Standard tables published by the IPCEA
9. Grainger, John J. and Stevenson W. D. *Power System Analysis*. New York: McGraw-Hill Inc., c1994.

– End of Section –



# Appendix A: Calculation of Losses – Method 1

The spreadsheet below calculates the losses in the power transformer and line. The transformer secondary delivers rated apparent power and secondary voltage. The power factor of the load is 0.92. Transformer characteristics are from factory test results. The line characteristics are from standard tables for overhead conductors

Definitions for this spread sheet

kVA := volt-amp·1000    MVA := 1000·kVA    kVAR := volt-amp·1000    MVAR := 1000·kVAR    pu := 1

**Transformer Data**

S<sub>Rated</sub> := 18·MVA    HV<sub>Tap</sub> := 130.0·kV    LV<sub>Tap</sub> := 4.16·kV    Z<sub>ShortCircuit</sub> := 9.32·%

NoLoadLoss := 16.62·kW    LoadLoss := 67.49·kW    I<sub>ex</sub> := 0.225·%

**Line Data, Positive Sequence**

R<sub>1</sub> := 1.686·ohm    X<sub>1</sub> := 3.7476·ohm    X'<sub>1</sub> := 42.847·KΩ    DielectricLoss := 0·kW

**Base Quantities, Per Phase**

$$S_b := \frac{S_{Rated}}{3} \quad V_b := \frac{HV_{Tap}}{\sqrt{3}} \quad I_b := \frac{S_b}{V_b} \quad Z_b := \frac{V_b}{I_b}$$

S<sub>b</sub> = 6.000·MVA    V<sub>b</sub> = 75.056·kV    I<sub>b</sub> = 79.941·amp    Z<sub>b</sub> = 938.889·ohm

**State at Node 4 set To 1 pu load and voltage**

PF := 0.92    V<sub>4</sub> := (1 + j·0)·pu    S<sub>4</sub> := 1·e<sup>j·acos(PF)</sup>·pu    I<sub>4</sub> :=  $\frac{S_4}{V_4}$     S<sub>4</sub> = 0.9200 + 0.3919j    I<sub>4</sub> = 0.9200 - 0.3919j·pu

**State at Node 3**

$$V_3 := V_4 \quad P_{NLL} := \frac{NoLoadLoss}{3 \cdot S_b} \quad Q_{NLL} := \sqrt{(V_3 \cdot I_{ex})^2 - P_{NLL}^2}$$

$$S_{NLL} := P_{NLL} + j \cdot Q_{NLL} \quad S_3 := S_4 + S_{NLL} \quad I_3 := \frac{S_3}{V_3}$$

S<sub>NLL</sub> = 0.000923 + 0.002052j·pu    S<sub>3</sub> = 0.9209 + 0.3940j·pu    I<sub>3</sub> = 0.9209 - 0.3940j·pu

$$G_T := \frac{P_{NLL}}{V_3^2} \quad G_T = 0.0009 \cdot pu$$

**State at Node 2**

$$I_{sc} := 1 \cdot pu \quad P_{LL} := \frac{LoadLoss}{3 \cdot S_b} \quad Q_{LL} := \sqrt{I_{sc}^4 \cdot Z_{ShortCircuit}^2 - P_{LL}^2} \quad S_{LL} := P_{LL} + j \cdot Q_{LL}$$

$$R_T := \frac{P_{LL}}{I_{sc}^2} \quad X_T := \frac{Q_{LL}}{I_{sc}^2} \quad Z_T := R_T + j \cdot X_T$$

S<sub>2</sub> := S<sub>3</sub> + S<sub>LL</sub>    I<sub>2</sub> := I<sub>3</sub>    V<sub>2</sub> := V<sub>3</sub> + I<sub>2</sub>·Z<sub>T</sub>

P<sub>LL</sub> = 0.003749·pu    Q<sub>LL</sub> = 0.093125·pu    S<sub>LL</sub> = 0.0037 + 0.0931j·pu

S<sub>2</sub> = 0.9247 + 0.4871j·pu    V<sub>2</sub> = 1.0401 + 0.0843j·pu    Z<sub>T</sub> = 0.0037 + 0.0931j·pu

3·S<sub>2</sub>·S<sub>b</sub> = 16.6441 + 8.7677j·MVA     $|V_2 \cdot \sqrt{3} \cdot V_b| = 135.6616 \cdot kV$

**Figure A.1: Calculation of losses in the transformer and line by Method 1**

Definitions for this spread sheet				
kVA := volt-amp·1000	MVA := 1000·kVA	kVAR := volt-amp·1000	MVAR := 1000·kVAR	pu := 1
Transformer Data				
S <sub>Rated</sub> := 18·MVA	HV <sub>Tap</sub> := 130.0·kV	LV <sub>Tap</sub> := 4.16·kV	Z <sub>ShortCircuit</sub> := 9.32·%	
NoLoadLoss := 16.62·kW	LoadLoss := 67.49·kW	I <sub>ex</sub> := 0.225·%		
Line Data, Positive Sequence				
R <sub>1</sub> := 1.686·ohm	X <sub>1</sub> := 3.7476·ohm	X' <sub>1</sub> := 42.847·KΩ	DielectricLoss := 0·kW	
Base Quantities, Per Phase				
$S_b := \frac{S_{\text{Rated}}}{3}$	$V_b := \frac{HV_{\text{Tap}}}{\sqrt{3}}$	$I_b := \frac{S_b}{V_b}$	$Z_b := \frac{V_b}{I_b}$	
S <sub>b</sub> = 6.000·MVA	V <sub>b</sub> = 75.056·kV	I <sub>b</sub> = 79.941·amp	Z <sub>b</sub> = 938.889·ohm	
Calculated Transformer Data				
Open Circuit Test:	V <sub>test</sub> := 1·pu	P <sub>NLL</sub> := $\frac{\text{NoLoadLoss}}{3 \cdot S_b}$	Q <sub>NLL</sub> := $\sqrt{(V_{\text{test}} \cdot I_{\text{ex}})^2 - P_{\text{NLL}}^2}$	
	S <sub>NLL</sub> := P <sub>NLL</sub> + j·Q <sub>NLL</sub>		S <sub>NLL</sub> = 0.0009233 + 0.0020518j·pu	
	G <sub>T</sub> := $\frac{P_{\text{NLL}}}{V_{\text{test}}^2}$	G <sub>T</sub> = 0.0009233·pu		
Short Circuit Test:	I <sub>test</sub> := 1·pu	P <sub>LL</sub> := $\frac{\text{LoadLoss}}{3 \cdot S_b}$	Q <sub>LL</sub> := $\sqrt{I_{\text{test}}^4 \cdot Z_{\text{ShortCircuit}}^2 - P_{\text{LL}}^2}$	
	S <sub>LL</sub> := P <sub>LL</sub> + j·Q <sub>LL</sub>	S <sub>LL</sub> = 0.003749 + 0.093125j·pu		
	R <sub>T</sub> := $\frac{P_{\text{LL}}}{ I_{\text{test}} ^2}$	X <sub>T</sub> := $\frac{Q_{\text{LL}}}{ I_{\text{test}} ^2}$	Z <sub>T</sub> := R <sub>T</sub> + j·X <sub>T</sub>	Z <sub>T</sub> = 0.003749 + 0.093125j·pu
Calculated Line Data				
Series Data:	R <sub>L</sub> := $\frac{R_1}{Z_b}$	X <sub>L</sub> := $\frac{X_1}{Z_b}$	Z <sub>L</sub> := R <sub>L</sub> + j·X <sub>L</sub>	Z <sub>L</sub> = 0.001796 + 0.003992j·pu
Shunt Data:	G <sub>L</sub> := $\frac{\text{DielectricLoss}}{3 \cdot S_b}$	B <sub>L</sub> := $\frac{Z_b}{X'_1}$	Y <sub>L</sub> := G <sub>L</sub> + j·B <sub>L</sub>	Y <sub>L</sub> = 0.0219j·pu

Figure A.2: Calculation of losses in the transformer and line

State at Node 4 at 1 pu load and 1 pu voltage

$$PF := 0.92 \quad V_4 := (1 + j \cdot 0) \cdot pu \quad S_4 := 1 \cdot e^{j \cdot \arccos(PF)} \cdot pu \quad I_4 := \sqrt{\frac{S_4}{V_4}} \quad S_4 = 0.9200 + 0.3919j \quad I_4 = 0.9200 - 0.3919j \cdot pu$$

State at Node 3

$$V_3 := V_4 \quad S_3 := S_4 + S_{NLL} \quad I_3 := \sqrt{\frac{S_3}{V_3}} \quad S_3 = 0.9209 + 0.3940j \cdot pu \quad I_3 = 0.9209 - 0.3940j \cdot pu$$

State at Node 2

$$I_2 := I_3 \quad V_2 := V_3 + I_2 \cdot Z_T \quad S_2 := V_2 \cdot \overline{I_2} \quad S_2 = 0.9247 + 0.4874j \cdot pu \quad |V_2| = 1.0436 \cdot pu$$

State at Node 1

$$I_L := I_2 + 0.5 \cdot Y_L \cdot V_2 \quad V_1 := V_2 + Z_L \cdot I_L \quad I_1 := I_L + 0.5 \cdot Y_L \cdot V_1 \quad S_1 := V_1 \cdot \overline{I_1}$$

$$|V_1| = 1.0470 \cdot pu \quad |I_1| = 0.9912 \cdot pu \quad I_L = 0.9200 - 0.3826j \cdot pu \quad S_1 = 0.9265 + 0.4674j \cdot pu$$

Transformer Losses, Per Phase

Voltage Dependent:  $P_{VT} := |V_3|^2 \cdot G_T \cdot S_b \quad Q_{VT} := Q_{NLL} \cdot V_3^4 \cdot S_b \quad P_{VT} = 5.54 \cdot kW \quad Q_{VT} = 12.31 \cdot kVAR$

Current Dependent:  $P_{IT} := |I_3|^2 \cdot R_T \cdot S_b \quad Q_{IT} := |I_3|^2 \cdot X_T \cdot S_b \quad P_{IT} = 22.57 \cdot kW \quad Q_{IT} = 560.60 \cdot kVAR$

Line Losses, Per Phase

Voltage Dependent:  $P_{VL} := 0.5 \cdot G_L \cdot S_b \cdot (|V_1|^2 + |V_2|^2) \quad Q_{VL} := 0.5 \cdot B_L \cdot S_b \cdot (|V_1|^2 + |V_2|^2)$

$$P_{VL} = 0.0000 \cdot kW \quad Q_{VL} = 143.65 \cdot kVAR \text{ (Leading)}$$

Current Dependent:  $P_{IL} := |I_L|^2 \cdot R_L \cdot S_b \quad Q_{IL} := |I_L|^2 \cdot X_L \cdot S_b \quad P_{IL} = 10.70 \cdot kW \quad Q_{IL} = 23.78 \cdot kVAR$

Check Calculations, Per Phase

$$0.5 \cdot \overline{Y_L} \cdot (|V_1|^2 + |I_L|^2 \cdot Z_L + 0.5 \cdot \overline{Y_L} \cdot |V_2|^2) = 0.001783 - 0.019978j \cdot pu \quad \text{Ok: Sum of losses in each line component equals the difference between the power in and the power out.}$$

$$S_1 - S_2 = 0.001783 - 0.019978j$$

$$|I_2|^2 \cdot Z_T + S_{NLL} = 0.004685 + 0.095485j \cdot pu \quad \text{Ok: Sum of losses in each transformer component equals the difference between the power in and the power out.}$$

$$S_2 - S_4 = 0.004685 + 0.095485j \cdot pu$$

$$P_{VT} + P_{IT} + P_{VL} + P_{IL} + j \cdot (Q_{VT} + Q_{IT} - Q_{VL} + Q_{IL}) = 38.81 + 453.04j \cdot kVA \quad \text{Ok: Power loss in line plus power loss in transformer matches difference between power at point of sale and actual meter point.}$$

$$(S_1 - S_4) \cdot S_b = 38.81 + 453.04j \cdot kVA$$

Loss for Three Phases

Transformer:  $3 \cdot S_b \cdot (S_2 - S_4) = 84.33 + 1718.73j \cdot kVA$

Line:  $3 \cdot S_b \cdot (S_1 - S_2) = 32.09 - 359.61j \cdot kVA$

Total:  $3 \cdot S_b \cdot (S_1 - S_4) = 116.42 + 1359.12j \cdot kVA$

Figure A.3: Calculation of losses in the transformer and line (continued)

Parameters for Loss Model, Per Phase on Secondary Side of Transformer

$$V_b := \frac{LV_{Tap}}{\sqrt{3}} \quad V_b = 2402 \cdot V \quad I_b := \frac{S_b}{V_b} \quad I_b = 2498.15 \text{ A}$$

$$VT_{ratio} := \frac{2400 \cdot V}{120 \cdot V} \quad CT_{ratio} := \frac{2500 \cdot A}{5 \cdot A}$$

The meter will report the metered current and voltage in each phase (labelled R, Y & B) as:

$$I2R := \left( \frac{|I_4| \cdot |I_b|}{CT_{ratio}} \right)^2 \quad I2R = 24.9630 \text{ A}^2 \quad V2R := \left( \frac{|V_4| \cdot |V_b|}{VT_{ratio}} \right)^2 \quad V2R = 14421 \cdot V^2$$

$$I2Y := \left( \frac{|I_4| \cdot |I_b|}{CT_{ratio}} \right)^2 \quad I2Y = 24.9630 \text{ A}^2 \quad V2Y := \left( \frac{|V_4| \cdot |V_b|}{VT_{ratio}} \right)^2 \quad V2Y = 14421 \cdot V^2$$

$$I2B := \left( \frac{|I_4| \cdot |I_b|}{CT_{ratio}} \right)^2 \quad I2B = 24.9630 \text{ A}^2 \quad V2B := \left( \frac{|V_4| \cdot |V_b|}{VT_{ratio}} \right)^2 \quad V2B = 14421 \cdot V^2$$

The parameters required for the standard loss model are:

Transformer Loss:

$$A := \frac{P_{VT}}{V2R} \quad B := \frac{P_{IT}}{I2R} \quad C := \frac{Q_{VT}}{V2R^2} \quad D := \frac{Q_{IT}}{I2R}$$

$$A = 3.842 \cdot 10^{-4} \frac{\text{kW}}{\text{volt}^2} \quad B = 0.9042 \frac{\text{kW}}{\text{amp}^2} \quad C = 5.919 \cdot 10^{-8} \frac{\text{kVAR}}{\text{volt}^4} \quad D = 22.4571 \frac{\text{kVAR}}{\text{amp}^2}$$

Line Loss:

$$E := 0.5 \cdot \frac{|V_1|^2 + |V_2|^2}{V2R} \cdot S_b \cdot G_L \quad F := \frac{|I_L|^2 \cdot R_L \cdot S_b}{I2R} \quad G := -0.5 \cdot \frac{|V_1|^2 + |V_2|^2}{V2R} \cdot S_b \cdot B_L \quad H := \frac{|I_L|^2 \cdot X_L \cdot S_b}{I2R}$$

$$E = 0.0000 \frac{\text{kW}}{\text{volt}^2} \quad F = 0.4285 \frac{\text{kW}}{\text{amp}^2} \quad G = -0.009961 \frac{\text{kVAR}}{\text{volt}^2} \quad H = 0.9524 \frac{\text{kVAR}}{\text{amp}^2}$$

**Note:** G is negative because the line supplies capacitive vars. All other var quantities are inductive and the corresponding coefficients are therefore positive.

The standard loss model will calculate the transformer and line losses as:

$$P_{Tran} := A \cdot (V2R + V2Y + V2B) + B \cdot (I2R + I2Y + I2B) \quad P_{Tran} = 84.33 \cdot \text{kW}$$

$$Q_{Tran} := C \cdot (V2R^2 + V2Y^2 + V2B^2) + D \cdot (I2R + I2Y + I2B) \quad Q_{Tran} = 1718.73 \cdot \text{kVAR} \quad (\text{Lagging})$$

$$P_{Line} := E \cdot (V2R + V2Y + V2B) + F \cdot (I2R + I2Y + I2B) \quad P_{Line} = 32.09 \cdot \text{kW}$$

$$Q_{Line} := G \cdot (V2R + V2Y + V2B) + H \cdot (I2R + I2Y + I2B) \quad Q_{Line} = -359.61 \cdot \text{kVAR} \quad (\text{Leading})$$

**Figure A.4: Calculation of losses in the transformer and line (continued)**

The figure below illustrates the development of coefficients for the standard loss model when two-element metering is deployed. The transformer, line and loading data are the same as Example 1, above.

**Parameters for Loss Model with Two Element Metering on Secondary Side of Transformer**

Note: The 4.16 kV system is normally four wire and would usually be metered with three element metering. The two element metering and the VT ratio illustrated here are for demonstration purposes only.

$LV_{Tap} = 4.16 \text{ kV}$        $V_b := LV_{Tap}$        $S_b := S_{Rated}$        $S_b = 18.0 \text{ MVA}$        $I_b := \frac{S_b}{\sqrt{3} \cdot V_b}$        $I_b = 2498.15 \text{ A}$

$VT_{ratio} := \frac{4200 \cdot V}{120 \cdot V}$        $CT_{ratio} := \frac{2500 \cdot A}{5 \cdot A}$

The meter will report the metered current and voltage in each phase (labelled R, B) as:

$I_{2R} := \left( \frac{I_4 \cdot I_b}{CT_{ratio}} \right)^2$        $I_{2R} = 24.9630 \text{ A}^2$        $V_{2R} := \left( \frac{V_4 \cdot V_b}{VT_{ratio}} \right)^2$        $V_{2R} = 14127 \text{ v}^2$

$I_{2B} := \left( \frac{I_4 \cdot I_b}{CT_{ratio}} \right)^2$        $I_{2B} = 24.9630 \text{ A}^2$        $V_{2B} := \left( \frac{V_4 \cdot V_b}{VT_{ratio}} \right)^2$        $V_{2B} = 14127 \text{ v}^2$

The parameters required for the standard loss model are:

**Transformer Loss:**

$A := \frac{3 \cdot P_{VT}}{V_{2R} + V_{2B}}$        $B := \frac{3 \cdot P_{IT}}{I_{2R} + I_{2B}}$        $C := \frac{3 \cdot Q_{VT}}{V_{2R}^2 + V_{2B}^2}$        $D := \frac{3 \cdot Q_{IT}}{I_{2R} + I_{2B}}$

$A = 5.882 \cdot 10^{-4} \frac{\text{kW}}{\text{volt}^2}$        $B = 1.3563 \frac{\text{kW}}{\text{amp}^2}$        $C = 9.253 \cdot 10^{-8} \frac{\text{kVAR}}{\text{volt}^4}$        $D = 33.6857 \frac{\text{kVAR}}{\text{amp}^2}$

**Line Loss:**

$E := 0.5 \cdot \frac{|V_1|^2 + |V_2|^2}{V_{2R} + V_{2B}} \cdot S_b \cdot G_L$        $F := \frac{I_L^2 \cdot R_L \cdot S_b}{I_{2R} + I_{2B}}$        $G := -0.5 \cdot \frac{|V_1|^2 + |V_2|^2}{V_{2R} + V_{2B}} \cdot S_b \cdot B_L$        $H := \frac{I_L^2 \cdot X_L \cdot S_b}{I_{2R} + I_{2B}}$

$E = 0.0000 \frac{\text{kW}}{\text{volt}^2}$        $F = 0.6427 \frac{\text{kW}}{\text{amp}^2}$        $G = -0.015252 \frac{\text{kVAR}}{\text{volt}^2}$        $H = 1.4287 \frac{\text{kVAR}}{\text{amp}^2}$

**Note:** G is negative because the line supplies capacitive vars. All other var quantities are inductive and the corresponding coefficients are therefore positive.

The standard loss model will calculate the transformer and line losses for a two element meter as:

$P_{Tran} := A \cdot (V_{2R} + V_{2B}) + B \cdot (I_{2R} + I_{2B})$        $P_{Tran} = 84.33 \text{ kW}$

$Q_{Tran} := C \cdot (V_{2R}^2 + V_{2B}^2) + D \cdot (I_{2R} + I_{2B})$        $Q_{Tran} = 1718.73 \text{ kVAR (Lagging)}$

$P_{Line} := E \cdot (V_{2R} + V_{2B}) + F \cdot (I_{2R} + I_{2B})$        $P_{Line} = 32.09 \text{ kW}$

$Q_{Line} := G \cdot (V_{2R} + V_{2B}) + H \cdot (I_{2R} + I_{2B})$        $Q_{Line} = -359.61 \text{ kVAR (Leading)}$

**Figure A.5: Calculation of losses in the transformer and line for two-element metering by Method 1**



# Appendix B: Application of Method 2

The calculations below illustrate the application of Method 2 to a three-winding power transformer.

Definitions for this spread sheet

kVA := voltamp-1000    MVA := 1000-kVA    kVAR := voltamp-1000    MVAR := 1000-kVAR    pu := 1

Transformer Data

U <sub>p</sub> := 50-MVA	U <sub>s</sub> := 30-MVA	U <sub>t</sub> := 20-MVA
Z <sub>ps</sub> := 14.7 %	Z <sub>pt</sub> := 23.1 %	Z <sub>st</sub> := 6.34 %
LoadLoss <sub>ps</sub> := 195.2-kW	LoadLoss <sub>pt</sub> := 67.45-kW	LoadLoss <sub>st</sub> := 88.62-kW
Tap <sub>p</sub> := 241.5-kV	Tap <sub>s</sub> := 44.0-kV	Tap <sub>t</sub> := 27.6-kV
NoLoadLoss := 165.62-kW	I <sub>ex</sub> := 1.34-%	

Base Quantities, Per Phase

$$S_b := \frac{U_p}{3} \quad V_b := \frac{\text{Tap}_p}{\sqrt{3}} \quad I_b := \frac{S_b}{V_b} \quad Z_b := \frac{V_b}{I_b}$$

S<sub>b</sub> = 16.667·MVA    V<sub>b</sub> = 139.430·kV    I<sub>b</sub> = 119.534·amp    Z<sub>b</sub> = 1166.445·ohm

Calculated Transformer Data

Open Circuit Test: V<sub>test</sub> := 1·pu    P<sub>NLL</sub> :=  $\frac{\text{NoLoadLoss}}{3 \cdot S_b}$     Q<sub>NLL</sub> :=  $\sqrt{(V_{\text{test}} \cdot I_{\text{ex}})^2 - P_{\text{NLL}}^2}$

S<sub>NLL</sub> := P<sub>NLL</sub> + j · Q<sub>NLL</sub>    S<sub>NLL</sub> = 0.003312 + 0.012984j·pu

G<sub>T</sub> :=  $\frac{P_{\text{NLL}}}{V_{\text{test}}^2}$     G<sub>T</sub> = 0.0033124·pu

Short Circuit Test:

I<sub>test</sub> := 1·pu    P<sub>LLps</sub> :=  $\frac{\text{LoadLoss}_{ps}}{3 \cdot S_b}$     Q<sub>LLps</sub> :=  $\sqrt{I_{\text{test}}^4 \cdot Z_{ps}^2 - P_{\text{LLps}}^2}$

R<sub>ps</sub> :=  $\frac{P_{\text{LLps}}}{I_{\text{test}}^2}$     X<sub>ps</sub> :=  $\frac{Q_{\text{LLps}}}{I_{\text{test}}^2}$     Z<sub>ps</sub> := R<sub>ps</sub> + j · X<sub>ps</sub>    Z<sub>ps</sub> = 0.003904 + 0.146948j·pu

P<sub>LLpt</sub> :=  $\frac{\text{LoadLoss}_{pt}}{3 \cdot S_b}$     Q<sub>LLpt</sub> :=  $\sqrt{I_{\text{test}}^4 \cdot Z_{pt}^2 - P_{\text{LLpt}}^2}$

R<sub>pt</sub> :=  $\frac{P_{\text{LLpt}}}{I_{\text{test}}^2}$     X<sub>pt</sub> :=  $\frac{Q_{\text{LLpt}}}{I_{\text{test}}^2}$     Z<sub>pt</sub> := R<sub>pt</sub> + j · X<sub>pt</sub>    Z<sub>pt</sub> = 0.001349 + 0.230996j·pu

P<sub>LLst</sub> :=  $\frac{\text{LoadLoss}_{st}}{U_s}$     Q<sub>LLst</sub> :=  $\sqrt{I_{\text{test}}^4 \cdot Z_{st}^2 - P_{\text{LLst}}^2}$

R<sub>st</sub> :=  $\frac{P_{\text{LLst}}}{I_{\text{test}}^2}$     X<sub>st</sub> :=  $\frac{Q_{\text{LLst}}}{I_{\text{test}}^2}$     Z<sub>st</sub> := R<sub>st</sub> + j · X<sub>st</sub>    Z<sub>st</sub> = 0.002954 + 0.063331j·pu

**Figure B.1: Application of Method 2 to a three-winding power transformer**

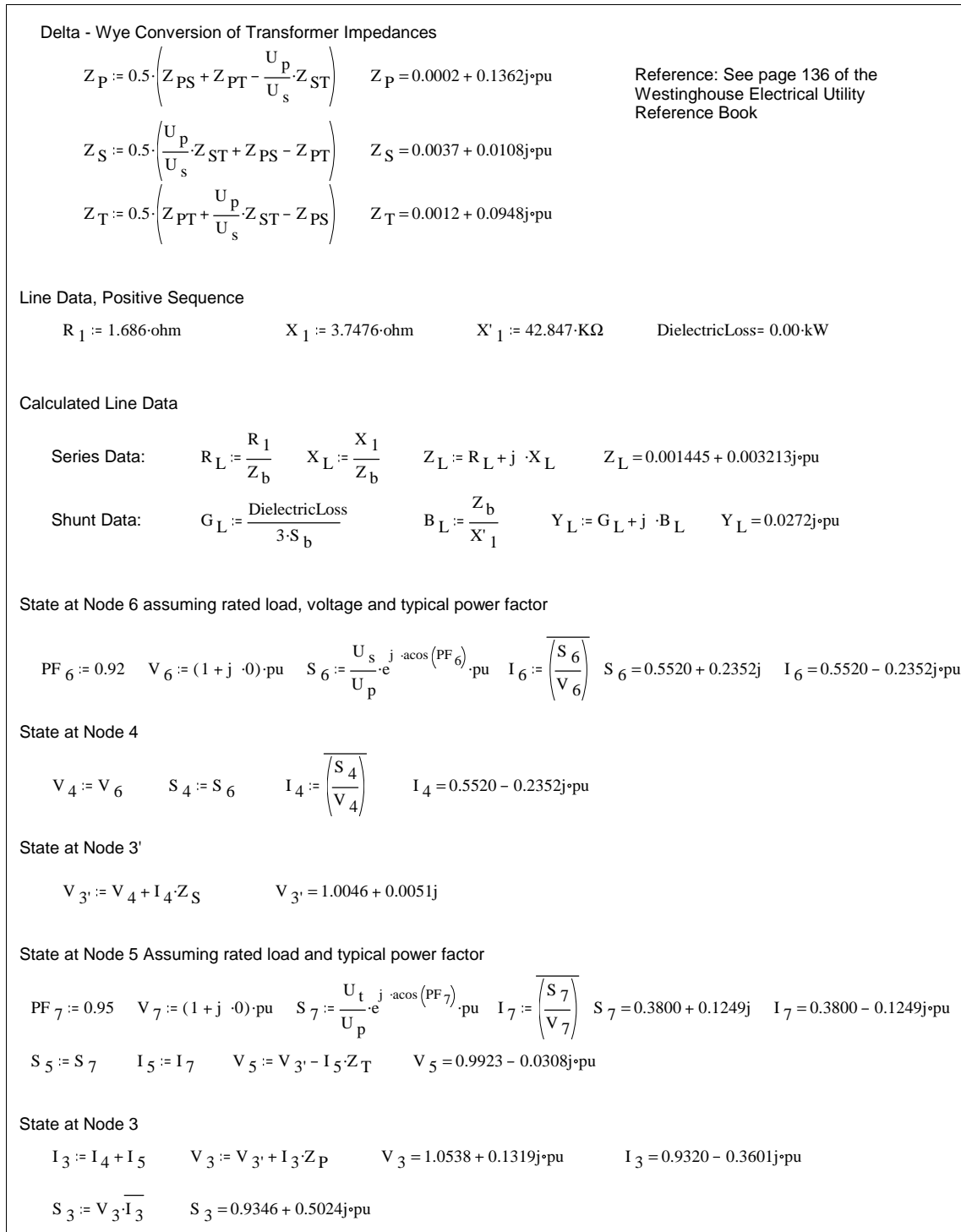

**Figure B.2: Application of Method 2 to a three-winding power transformer (continued)**

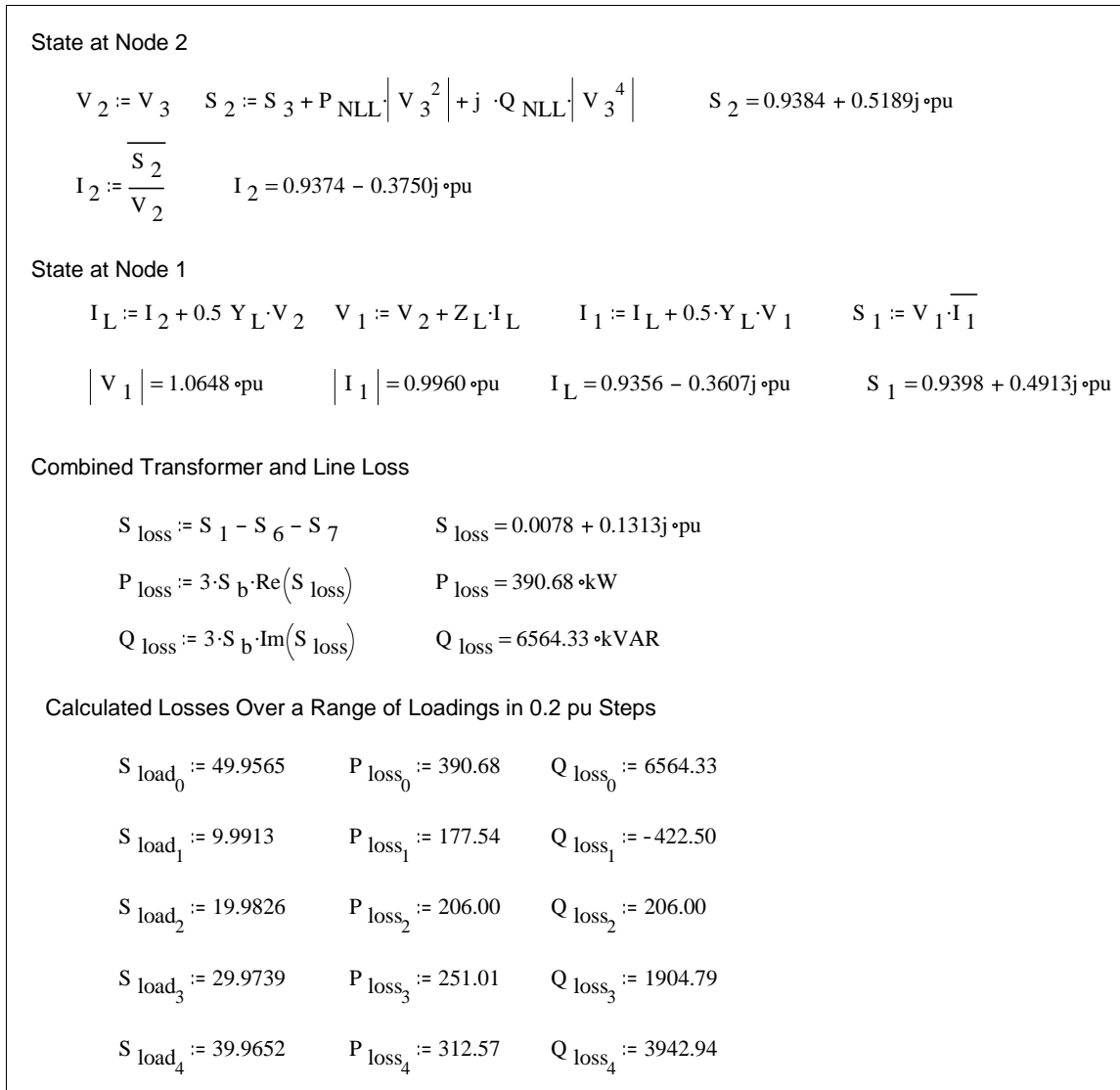

**Figure B.3: Application of Method 2 to a three-winding power transformer (continued)**

– End of Section –



# References

---

Document Name	Document ID

– End of Document –