

**UNITED STATES OF AMERICA
BEFORE THE
FEDERAL ENERGY REGULATORY COMMISSION**

Preventing Undue Discrimination and Preference in Transmission Services))))
Docket No. RM05-25-000

COMMENTS OF THE ISO/RTO COUNCIL

Pursuant to the Commission’s Notice of Inquiry (“Notice”) issued in the above-captioned proceeding, issued September 16, 2005, the ISO/RTO Council (“IRC”) respectfully submits these Comments concerning, among other things, “whether reforms are needed to the Order No. 888 Pro Forma Open Access Transmission Tariff (“OATT”) and the OATTs of public utilities to prevent undue discrimination and preference in the provision of transmission services.”¹ The nine functioning Independent System Operators and Regional Transmission System Organizations (“ISOs” and “RTOs,” respectively) in North America formed the IRC in April 2003. The IRC is comprised of the Alberta Electric System Operator (“AESO”), California Independent System Operator Corporation (“CAISO”), Electric Reliability Council of Texas (“ERCOT”), the Independent Electricity System Operator of Ontario (“IESO”), ISO New England Inc. (“ISO-NE”), Midwest Independent Transmission System Operator, Inc. (“MISO”), New York Independent System Operator, Inc. (“NYISO”), PJM Interconnection, L.L.C. (“PJM”), and the Southwest Power Pool (“SPP”). The IRC’s mission is to work collaboratively to develop effective processes, tools and standard methods for improving competitive electricity markets across North America. In fulfilling this mission, it is the

¹ 112 FERC ¶61,299 at P 2.

IRC's goal to provide a perspective that balances reliability standards with market practices so that each complements the other.

In these Comments, the IRC details how the ISO/RTO model addresses many of the concerns raised by the Commission in the Notice and provides specific examples as applicable.² Although the IRC does *not* seek to impose its structural model on other regions of the country, it does believe that the ways that ISO/RTOs address discrimination through their market rules and structure may help to inform judgments on the critical discrimination issues that the Commission raises. Moreover, the IRC believes it is equally important that the Commission not use this proceeding to order changes to established tariffs in regions which have moved significantly beyond the Order No. 888 OATT simply in the name of uniformity. ISOs and RTOs have used stakeholder processes to address many of the issues raised here and have used those processes to develop their present market structures which are designed to ensure non-discriminatory

² ERCOT has elected not to participate in these Comments. The IESO and AESO, of the respective Canadian Provinces of Ontario and Alberta, are not subject to the Commission's jurisdiction. Although IESO concurs with these Comments, such concurrence does not constitute agreement or acknowledgement that the IESO is subject to this Commission's jurisdiction. The AESO appreciates the opportunity to provide comments because the FERC's Order No. 888 Pro Forma Tariff does have an impact on Alberta. Although the AESO does not disagree with the overall intent of this submission, the substantive comments do not relate to the AESO due to Alberta's market structure. With that in mind, AESO will not join in these Comments, but will provide comments relevant to the AESO via a separate submission recognizing Alberta's market structure and unique situation of being connected to the rest of the Western Interconnection through British Columbia where FERC Order No. 888 Pro Forma Tariffs are applied. The IRC also notes that its RTO members are in various stages of market development. Consequently, the comment reflected herein should be understood in the context of the particular facts and circumstances of each member. Thus, for example, IRC members who have yet to implement bulk power markets have not fully considered or resolved issues concerning effective congestion management and/or embedded cost recovery. Such issues will be addressed as these entities transition to day-ahead and real-time markets. ISO-NE joins in these Comments with regard to its administration and provision of transmission service over regional network facilities (referred to in the ISO OATT as "Pool Transmission Facilities" or "PTF"), and not with regard to the manner in which transmission service is provided over either: (a) lower-voltage, local transmission facilities (referred to as "non-PTF") or (b) those transmission facilities whose costs are not included in regional rates that provide interties with neighboring control areas (referred to as "Merchant Transmission Facilities" or "Other Transmission Facilities").

access to the transmission grid in their respective regions.³ It is in this spirit that the IRC offers these Comments.⁴

I. Summary

The Commission's inquiry essentially focuses on what can be done to improve the Pro Forma OATT so as to address the potential for discrimination by an entity that both operates the transmission grid and serves as a market participant. The Commission also seeks to improve the rules regarding the purchase of transmission under the Order 888 paradigm, where transmission service is a discrete product corresponding to a particular physical-contractual path. Because of their inherent independence, the transparency of their procedures, and the progress achieved in developing effective financial and non-financial congestion management tools, ISO/RTOs are able to address structurally the continuing concerns of the Commission regarding persistent undue discrimination and preferences in the industry. The prevailing ISO/RTO model employs such tools as financially based network service and LMP⁵ to achieve more efficient use of the transmission system. Scarce transmission resources are better used where economic tools such as financial reservation transmission service and LMP rather than physical tools

³ The state commissions within each U.S. ISO/RTO footprint have played an extremely important role in the review of the ISO/RTOs market rules. Although not jurisdictional to the state commissions, each ISO/RTO is committed to working closely with its individual states and Regional State Committee (where such is formed), to continue to effectuate changes which provide benefits to ultimate consumers.

⁴ Although the IRC also offers commentary on the specific points raised in this proceeding by the Commission, certain IRC members plan to provide more detailed responses based on their operational experience and particular circumstances in individual comments submitted in this docket.

⁵ The CAISO, ERCOT, ISO-NE, MISO, NYISO and PJM either already have or are in the process of developing LMP systems. Although these systems are not always called "LMP," they are collectively referred to as "LMP" systems herein. Ontario's IESO utilizes an LMP dispatch process while settling participants using LMP at the seams and a uniform unconstrained price within the Province. SPP uses physical tools such as physical reservations and curtailments.

such as ATC reservations and TLR curtailments are employed.⁶ The ISO/RTOs utilize these market-based mechanisms to effectuate NERC reliability criteria and will do the same with ERO criteria.⁷

Moreover, the Commission should take care to preserve the progress that has been made in the ISO/RTO regions. A concern for uniformity does not justify blanket changes to ISO/RTO tariffs that would put at risk what has been achieved thus far and may take away from efforts to realize other goals on their and the Commission's agenda. Unlike regions without such institutions, regions hosting ISO/RTOs have open stakeholder processes where tariff changes are considered and voted upon by the ISO/RTO's independent board prior to their submission to the Commission. There is no reason to allow a generic docket to trump the very open and independent processes that this Commission has recognized in the past.⁸

Although the Commission may decide that blanket changes are necessary to the Pro Forma OATT for non-independent transmission providers, it should recognize that ISO/RTO regions have taken a variety of paths, each of which ensures that the fundamental objectives of open and nondiscriminatory access are achieved. Indeed, the Commission has approved RTO-specific innovations that promote the core values behind this Notice: non-discriminatory open transmission access, economically-efficient

⁶ As noted in Order No. 2000 (at pp. 31,126–27), an effective congestion management system, such as one using LMP essentially can achieve most, if not all, that the Commission would accomplish with this reform effort.

⁷ For this reason, the ISO/RTO Council urges the Commission to ensure that ERO standards are broad enough in scope and neutral as between market and non-market areas so as to be internationally enforceable without a plethora of regional differences. *See* Comments of the ISO/RTO Council on Proposed Regulations, Docket No. RM05-30-000 at 12–13, filed October 7, 2005.

⁸ *See, e.g., ISO New England, Inc., et al.*, 113 FERC ¶61,157 at PP 15, 24 (2005); *Midwest Independent Transmission System Operator, Inc., et al.*, 113 FERC ¶61,194 at PP 42–43 (2005).

markets, and reliable system operations.⁹ The existing OATTs of the ISO/RTOs reflect these innovations. They already differ significantly from the Pro Forma OATT of Order No. 888. Each ISO/RTO's OATT is the result of a process of adaptation to its region and to the particular circumstances of the system it operates.¹⁰ This is true for all ISO/RTOs, but especially so for those who have implemented LMP. Moreover, such adaptation has occurred with the benefit of input from a Commission-approved stakeholder process. As a result, current ISO/RTO OATTs are not only independently-administered and region-specific, but also the result of a transparent process. Were the Commission to place the ISO/RTOs under the aegis of another uniform tariff, this would disrupt this process of adaptation to the detriment of the progress that the Commission has made in approving individual RTO approaches and to the market participants and consumers who have benefited from regionally-adapted RTO market models. Such an approach would also forego the benefits of the progress ISO/RTOs have made in broadening the scope of their markets and in smoothing out the seams among their markets.

In many initiatives currently underway, the ISO/RTOs are working with the Commission to ensure that their markets work efficiently, send the right price signals for new investment in infrastructure, create seamless markets and implement effective longer term regional planning. Blanket changes to ISO/RTO tariffs rather than a more targeted approach addressing the particular issues existing in ISO/RTO regions, risks impeding

⁹ Examples includes PJM's development of ARRs to address the issue [of the extent of native load's entitlement to transmission], *PJM Interconnection, L.L.C.*, 102 FERC ¶61,276 (2003), *order denying reh'g*, 106 FERC ¶61,049 (2004).

¹⁰ For example, the Midwest ISO has filed over 100 revisions to the Pro Forma OATT to address issues related to the provision of regional transmission service and its multi-control area construct. A significant portion of these changes were vetted through the Midwest ISO stakeholder process and accepted by this Commission.

this momentum. Regardless of the degree of uniformity that the Commission concludes is necessary to achieve its objectives in areas where transmission providers are not independent of market participants, the Commission should be sure that customers in areas served by ISOs and RTOs that achieve the same objectives, are not forced to bear the costs that inflexible constraints sometimes impose.

In addition to providing a brief explanation of how ISO and RTOs resolve the problems in each of the areas that are of interest to the Commission, the IRC has endeavored, where available, to provide the Commission with data and analyses that support these claims.

II. Specific Comments

A. Undue Discrimination Generally

The administration of the OATT by an ISO/RTO substantially eliminates the problem of unduly discriminatory or preferential access to the existing transmission system in the ISO/RTO's region. Because they are independent, ISO/RTOs have no motivation to discriminate regardless of whether the tariffs or market rules would afford such opportunities.¹¹ Transparency and independence are two of the key elements that ensure nondiscriminatory operation of the grid. For example, all transmission service, not just that service remaining after consideration of native load, is ordered through the ISO/RTO.¹² Real-time information concerning the state of the grid is constantly updated.

¹¹ The IRC notes that the efficiency of the governance structures of ISOs and RTOs and the ability for ISO/RTO Boards to advance proposals to the Commission in the event of a lack of stakeholder consensus is critical to ensuring that RTOs exercise their independence and obligations to prevent undue discrimination in an effective manner.

¹² RTOs with organized markets do protect native load transactions but do so through use of financial transmission rights that protect native load from congestion costs rather than through physically trying to maintain one transaction over another.

By viewing the posted “costs” of congestion as well as day-ahead and real-time spot market prices, market participants can make informed economic decisions on whether they wish to continue their transactions. In addition, ISO/RTOs undertake longer term activities, such as analyses of the state of the market, management of interconnection queues and regional planning in a transparent and open process. This transparency not only serves as a check on the ISO/RTO’s practices but also reveals to all, any discriminatory conduct in the operation of the market that might otherwise occur.

Non-discrimination is also inherent in the system of security constrained economic dispatch process used by ISO/RTOs. The dispatch automatically takes into account price, ramp and transmission constraints, but never ownership, in an effort to meet load in the most reliable and economic manner. Afterwards, an independent market monitor can review this dispatch, providing for a further check on discrimination in the use of the transmission system.

Although one may posit that with the ownership of transmission assets comes some potential risk of an exercise of market power, the opportunity for harm to the marketplace has been substantially reduced under the ISO/RTO framework. The ability to exercise transmission market power is addressed structurally in the ISO/RTO environment as a result of the transmission owner turning over operational control and planning of its system to the ISO/RTO and as a result of the ISO/RTO’s market monitoring function and inherent transparency. Although one must remain vigilant to ensure against the exercise of market power as a result of vertical integration, the IRC believes that the ISO/RTO independent structure, as well as market rules that build on

that structure, work to effectively control the specific instances of undue discrimination or preferences referenced by the Commission in this proceeding.

B. Transmission Pricing

1. LMP Pricing

Under the LMP model, reserving transmission is essentially a financial rather than physical transaction. This allows market participants to value their transactions in true economic terms, focusing on the delivered costs of energy rather than on devising contract paths or facing the threat of curtailment. The residual concern from a delivery standpoint is the price of congestion, which can be hedged using the increasingly sophisticated and variable range of products that certain ISO/RTOs have developed and continue to improve. By treating efficient access to the transmission system through a financial model, it is possible to avoid the conundrum that the physical flows on the electric grid do not correlate with the contractual paths between the origin and destination of the delivered product. In the ISO/RTO regions, transmission customers are benefiting from extremely flexible terms of service, use of the system is maximized, and the disconnection between contract path and physical flow which can lead to the curtailment of specific transactions is eliminated.

Market participants in ISO/RTO-organized markets enjoy significant savings as a result of security constrained economic dispatch over a wide footprint coupled with a financial rather than physical system of access to the transmission grid. Within organized markets, every market participant can see pricing information and thereby avoid sub-optimal decisions using less efficient resources. ISO/RTOs use security-constrained unit commitment software to dispatch the units with the lowest bids consistent with

transmission availability and grid reliability requirements. ISO/RTOs inform all market participants on the state of grid conditions, market operations and other key system information on their websites. The posted nodal prices reflect these real-time system conditions. LMP provides very specific signals as to where more generation or power delivery is needed and valued. The Commission has recognized this benefit:

“locational marginal, day-ahead and real time process, along with capacity and ancillary services within ISO/RTO markets, are almost entirely transparent and make much information available in real time. Such transparency rests on standardized operations and large, centralized mechanisms to collect and disseminate the information. By contrast, most ... bilateral electric markets provide far less detailed information. Some electric power markets are almost entirely opaque to both regulators and to price-takers. In these markets (such as electricity in much of the southeast), so little information is available that price indices either do not develop or have little value in price discovery.”¹³

FERC has also noted:

“Customers in regions without organized markets had significantly less market information about prices, price formation, system conditions and transmission infrastructure needs than their counterparts in regions with organized markets. Outside organized markets there was limited market price information regarding the value of electricity over time and across locations of the regional needs for transmission and generation siting, resulting in:

- Opaque (non-transparent) prices,
- Less-efficient dispatch of power plants
- Use of less-efficient congestion management tools, and
- Muted or distorted signals for investment, particularly where it is most needed.

The poor quality of information outside organized markets limited the effective functioning of wholesale

¹³ FERC 2004 State of the Market Report at 36.

electric markets in those areas, potentially resulting in higher costs to customers.¹⁴

LMP dissuades use of the least efficient plants unless they are needed for system reliability. In contrast, outside organized markets, dispatch may not always use the most efficient generators over a large footprint. Lacking information about which plants are operating and at what cost, customers and regulators cannot observe and correct this inefficiency.

These benefits have been confirmed in a variety of studies and analyses performed by both the ISOs and RTOs and by independent entities. For example, ISO-NE reports that after adjusting for the increase in fuel prices, wholesale prices of electricity in New England have declined by 5.7 percent since 2000—the first full year of ISO/RTO-facilitated wholesale competition. This reduction equaled approximately \$400 million in annual savings to the wholesale market. In that same period, New England market participants saved an additional \$300 million each year by reducing generation uplift costs, decreasing requirements for regulation service, and through a three percent improvement in generation availability rates. Similarly, PJM reports that after its region expanded to integrate American Electric Power in Spring 2004, fuel-adjusted energy prices declined by 4.2 percent resulting in an annual savings estimated at \$500 million.¹⁵

Similarly, when MISO began energy market operations in April 2005, it estimated that total savings from the introduction of centralized security constrained economic

¹⁴ FERC 2003 State of the Market Report at 8–9.

¹⁵ Edward N. Krapels and Paul Fleming, *Impacts of the PJM RTO Market Expansion*, Energy Security Analysis, Inc. (“ESAI”) at 58 (November 2005).

dispatch using LMP would yield annual gross production cost savings of approximately \$255 million across the Midwest.¹⁶

A variety of independent studies have confirmed these savings to consumers:

- *The Value of Independent Regional Grid Operators: A Report by the ISO/RTO Council* (November 2005) (“White Paper”).¹⁷
- Global Energy Decision, *Putting Competitive Power Markets to the Test: The Benefits of Competition in America’s Electric Grid* (July 2005).¹⁸
- ESAI, *Impacts of the PJM RTO Market Expansion* (November 2005).¹⁹
- Cambridge Energy Research Associates, *Beyond the Crossroads: The Future Direction of Power Industry Restructuring* (October 2005).
- Electric Reliability Counsel of Texas, *Market Restructuring Cost-Benefit Analysis: Final Report* (November 30, 2004).²⁰
- Synapse Energy Economics, Inc., *Electricity Prices in PJM: A Comparison of Wholesale Power Costs in the PJM Market to Indexed Generation Service Costs* (June 3, 2004).²¹
- Bernard C. Lesieutre, Emily Bartholomew, Joseph H. Eto, Douglas Hale, and Thanh Luong, *The Potential Impacts of a Competitive Wholesale Market in the Midwest: A Preliminary Examination of Centralized Dispatch*, Lawrence Berkeley National Laboratory (July 1, 2004).²²

¹⁶ FERC Docket Nos. ER04-691 and ER04-104-000, Dr. R.R. McNamara at 51, June 25, 2004.

¹⁷ A copy of this report is provided as an attachment to this document.

¹⁸ A copy of the report can be found at <http://www.globalenergy.com/competitivepower/competitivepower.pdf>.

¹⁹ A copy of the report can be found at <http://www.pjm.com/documents/downloads/reports/20051101-impact-pjm-expansion.pdf>.

²⁰ A copy of the report can be found at <http://www.ercot.com/TNT/default.cfm?func=documents&intGroupId=83&b=>.

²¹ A copy of the report can be found at <http://www.pjm.com/documents/downloads/reports/synapse-report-pjm-electricity-prices.pdf>.

²² A copy of the report can be found at <http://repositories.cdlib.org/lbnl/LBNL-56503>.

- Midwest ISO, *The Benefits and Costs of Wisconsin Utilities Participating in Midwest ISO Energy Markets* (March 26, 2004).
- Midwest ISO, Docket No. ER04-691-000, *et al.* (June 25, 2004) (providing information regarding flowgate utilization during Transmission Loading Relief events and the impact of grandfathered transmission agreements).
- Catherine Wolfram, *The Efficiency of Electricity Generation in the U.S. After Restructuring*, Center for the Study of Energy Markets (June 1, 2003).²³

The increased liquidity provided by the large and transparent markets operated by ISO/RTOs also provide substantial benefits, in particular by reducing the upward bias in the forward market compared to the spot market. ESAI notes, for example, that in inefficient and illiquid markets, the forward price is much higher than the spot market price. With increased liquidity, the size of that spread declines, loads pay for the premium price of forward markets where they are unwilling to take the volatility risks of buying primarily in the spot market. ESAI concludes, in its recent analysis of PJM, that “if ... energy turns out to be only \$2/MWh less than in the world of monopoly agents, the economic benefits of the spread of PJM’s platform would be measured at \$1.4 billion per year.”²⁴

A study prepared in July, 2005, by Global Energy Decisions entitled “Putting Competitive Markets to the Test—The Benefits of Competition in America’s Electric Grid: Cost Savings and Operating Efficiencies” concluded (at ES-1) that wholesale electric “customers realized \$15.1 billion in value from wholesale electric competition in the 1999–2003 study period” across the Eastern Interconnection, compared to a

²³ A copy of the report can be found at <http://repositories.cdlib.org/ucei/csem/CSEMWP-111R>.

²⁴ ESAI, *Impacts of the PJM RTO Market Expansion* at 39.

simulation of grid operation without wholesale competition. These savings came from increased construction and operation of highly efficient power plants by independent producers, selling at lower prices than would have been charged under cost-of-service rates without wholesale competition.

A 2005 cost-benefit study for the SPP's Regional State Committee on the impact of an SPP market for energy imbalance service within SPP indicated that the entire Eastern Interconnection would realize \$1.2 billion in production cost savings over ten years, over half of which will directly flow to SPP customers.²⁵

A report produced by Cambridge Energy Research Associates (CERA), "Beyond the Crossroads," found that, "U.S. residential electric customers paid about \$34 billion less for the electricity they consumed over the past seven years than they would have paid if traditional regulation had continued."²⁶ The study found that, contrary to popular belief, "deregulation of the U.S. power business has lowered power prices for the majority of electricity customers"—on average, 16 percent lower—compared to prior periods and to what prices would have been under traditional regulation. CERA finds that the Northeast, which has been restructured for the longest period, enjoyed the greatest electricity price reductions from competition, with savings equal to \$7.30 per MWh since 1997.

As demonstrated above, the performance of LMP within the ISOs and RTOs has brought significant benefits to customers. Moreover, the ISO/RTO's use of LMP has

²⁵ Charles River Associates, *Cost-Benefit Analysis Performed for the SPP Regional State Committee, Final Report* (July 27, 2005).

²⁶ CERA, *Beyond the Crossroads—The Future Direction of Power Industry Restructuring* at ES-1 (October 2005).

achieved the goal of non-discriminatory access and transparency that the Commission's Order No. 888 was designed to achieve. In implementing LMP, however, the ISO/RTOs have in many cases moved far beyond the Pro Forma OATT to ensure that the access provisions remained fully integrated into the ISO/RTO markets. The Commission should thus take care not to require specific revisions to the OATT that, though they may improve the operation of the OATT in territories outside the ISO/RTO markets, would be incompatible with or inapplicable to the more developed ISO/RTO tariffs.²⁷

2. *Embedded Costs*

One of the advantages of an effective congestion management system is that it separates payment for actual usage of the grid from the recovery of the transmission owners' embedded costs. For the embedded-cost component, transmission owners within ISO/RTOs have established a number of different mechanisms for cost recovery. Each such recovery system, however, complements the efficient use of the transmission grid that occurs through an effective, separately priced congestion management system.

This Commission, along with the ISOs and RTOs, has sought actively to implement transmission pricing models that promote the creation and use of strong regional transmission networks. Before ISO/RTO formation, an energy buyer who wanted to import electricity from a distant generator would have to pay a fee to every transmission owner on the path between the producer and the delivery point on the grid. One of the most valuable benefits of ISO/RTO formation for electricity buyers has been

²⁷ To take one example, the Commission asks whether it should consider revising its "higher of" policy which caps the price of transmission assigned to secondary purchasers. Notice at P 12 (question 6). In an LMP market, transmission customers already have the opportunity to make efficient economic decisions concerning their purchase of transmission which is ascertained by their willingness to pay the congestion charges associated with a particular request. Application of a change of this nature to a tariff using LMP risks introducing unnecessary confusion.

to eliminate these “pancaked rates” within the ISO/RTO footprint, substituting a single rate for transactions across multiple transmission systems within an ISO/RTO footprint while ensuring that the transmission owners would still be able to recover their costs.

The impact of eliminating rate pancaking that is enabled under the ISO/RTO structure where there is an entity that can bill and settle across multiple transmission zones has been substantial. For example, after the formation of MISO and the adoption of a single regional tariff, the cost for transmission service to deliver 100 MW of coal production for one hour from a plant in Vectren’s Indiana system through the Cinergy, NIPSCO and ITC transmission systems to Detroit dropped \$1,254.²⁸ Consider also the case of the NYISO and ISO-NE, which worked to eliminate “Through-and-Out” transmission service charges for exports between the two regions, effective December 2004, increasing the range of potential suppliers in both regions. Last year, the CAISO successfully obtained approval for its uniform access charge for high voltage transmission facilities.²⁹ The CAISO now is nearly half-way through its ten-year transition to a single system grid-wide rate for high-voltage transmission (at or greater than 200 kV). In 2011, users of the ISO-controlled grid will pay a single charge for use of the high-voltage system regardless of location. By that time, savings to load-serving entities in California already will have reached as high as \$23.9 million per year.³⁰ By the same token, in the PJM region, stakeholders are exploring the maintenance of license plate rates versus more flow-based pricing of the Extra High Voltage (EHV) system. In

²⁸ White Paper at 17.

²⁹ See *California Independent System Operator Corporation*, 109 FERC ¶ 61,301 (2004) (Opinion No. 478), *order on reh’g and clarification*, 111 FERC ¶61,337, *order denying reh’g and granting clarification*, 111 FERC ¶61,337 (2005).

³⁰ White Paper at 18.

New England, an eleven-year transition to a single transmission rate for regional transmission facilities will be completed in 2008. The common theme of these pricing models is that the recovery of embedded costs must, and can, complement rather than interfere with the most efficient dispatch of generation and demand-side response.³¹

C. Network and Point-to-Point Transmission Service

Although ISO/RTOs using LMP may still employ the OATT labels of “network” and “point to point” in their tariffs, they now have different meanings. Specifically, whether a customer orders network or point-to-point service in an ISO/RTO environment, the financial consequences are defined without reference to the physical flows, thus providing a significant degree of flexibility (and leaving the operator of the grid to focus on the physical flows, and reliability, without concern for the contract paths). Thus, as a practical matter, the Commission’s questions in this area do not apply to an LMP regime and hence to ISO/RTO tariffs.³² In the non-ISO/RTO world, some customers may still choose to purchase point-to-point service because the network service in the Pro Forma Tariff is significantly less flexible than an ISO/RTO’s product, essentially due to its “physical” rather than “financial” characteristics (*see supra* Sect. A). Consequently, the Commission should refrain from blanket revision to ISO/RTO tariffs with respect to point-to-point service because there is no distinction between different tiers of physical entitlements to the transmission system in an organized market environment.

³¹ By the same token, the Commission should ensure that its collection of its regulatory fees are neutral and non-discriminatory between ISO/RTO regions and non-ISO/RTO regions. Presently, ISO/RTO regions bear a far greater share of FERC fees than do non-ISO/RTO regions of comparable size and scope.

³² The CAISO does not separate network and PTP services. All transmission service (except that pursuant to existing transmission service contracts (ETCs) essentially is a network-type service that offers even more flexibility than traditional network service.

D. Untimely Processing of Requests for Transmission Service

ISO/RTOs are independent, having no affiliates active in the markets they administer, and operate according to transparent procedures and business practices. For an ISO/RTO to discriminate for or against any customer would be fundamentally contrary to its nature and purpose. The activities of ISO/RTOs do not implicate the Commission's concerns in the regions where they operate. Thus, there is no need to require blanket changes to the tariffs of ISO/RTOs in order to address the concerns that drive the Commission's inquiries with respect to the timing of requests for transmission service.

The ISO/RTO's performance reflects this lack of bias. ISO/RTOs can demonstrate an effective track record of processing transmission service requests in a non-discriminatory manner. The CAISO, for example, approves equal access to all available capacity on a daily basis. In PJM, all transactions are made financially firm on a day ahead basis with numerous private hedging instruments available for those who seek greater certainty along with a useful "self-supply" option.

Moreover, one benefit of the establishment of ISO/RTOs with a large footprint is to internalize what, in non-ISO/RTO areas, amounts to a cumbersome process of requesting transmission service from multiple entities. Where market participants once made multiple requests to every transmission provider along the path, with potentially different or incompatible timing and availability, customers now place a single request for service anywhere within or across the ISO/RTO region. As a result, generators taking

network service in PJM or MISO, for example, can reach millions of retail electric customers in 23 states and provinces and the District of Columbia.³³

E. Remedies, Penalties and Enforcement

Remedies, penalties and enforcement mechanisms of the sort under discussion here do not necessarily apply to ISO/RTOs. The incentive structure is market-based, and the market extracts “penalties” through higher costs such as congestion payments. Market Participants address these risks by using Auction Revenue Rights and Financial Transmission Rights. In other cases, such as operating reserves, the costs of reserve shortages are spread evenly over the market. An entity that is short of reserves will suffer the economic consequences of its actions. In our view, these economic impacts are both more equitable and more effective than relying on a system of pre-identified penalties to discourage “free riding.” For these reasons, the Commission should not order changes to ISO/RTO tariffs that relate to incentives for performance under a different model.

To the extent the Commission determines that remedies, penalties and enforcement provisions applicable to market participants operating in an ISO/RTO environment or the ISO/RTO itself may be appropriate, the Commission should take into account the transparency afforded under an ISO/RTO-administered platform. The Commission should not impose inapposite requirements or otherwise interfere with the business activities of market participants operating in a transparent ISO/RTO framework merely to maintain consistency with business practices in non-ISO/RTO administered regions.

³³ White Paper at 17.

F. Changes in Receipt and Delivery Points (Redirects)

Where ISOs and RTOs use LMP, the service offered to customers with respect to receipt and delivery points is extremely flexible, thus obviating the need for any additional tariff language to address the issue in RTO/ISO areas. No transmission customer is able to exploit its control of a constrained path to deny access to others and then convert its actual use of the system with a re-assignment of points of delivery and/or origin. Moreover, were it even possible to engage in this type of activity, such activity would be quickly detected by ISO/RTO operations and by the market monitor.

G. Rollover Rights

The ability to accommodate the rollover of pre-Order No. 888 contracts differs among the ISO/RTO regions, but such differences do not raise an issue of discriminatory treatment or undue preference because ISO/RTOs do not take service on the systems that they operate. Consequently, the IRC recommends that the Commission refrain from imposing particular tariff language with respect to rollover rights in RTO or ISO areas.

H. Rules, Standards and Practices Governing the Provision of Transmission Service

In this section, the Commission seeks comment on whether business practices of transmission providers should be included in a public utilities' OATTs or whether a posting on OASIS should be considered as a reasonable substitute. The IRC believes that the Commission's precedents as well as those of the courts are largely dispositive of this issue and should be followed. As detailed below, the courts have recognized that a "rule of reason" should apply as to what constitutes a matter to be included in a tariff versus those which can be addressed through operating practices. Moreover, the courts have recognized that there may be different applications of the rule, depending upon, for

example, whether the parties are competitors such that the exercise of a non-tariffed practice could lead to undue discrimination.

As stated by then Circuit Judge Scalia in *City of Cleveland v. FERC*, 773 F.2d 1368, 1370–71, 1376 (D.C. Cir. 1985):

An understanding of the current controversy requires appreciation of two underlying facts: First, that it is no more possible to set forth *all* of the practices affecting rates and services than it is to set forth *all* of the terms and conditions of a contract, leaving nothing whatever to be implied or to be governed by an unspecified standard of reasonableness. In the normal situation of ongoing purchase-sale relationships between utilities and their customers the specification of minor practices is not often the subject of dispute. The second underlying fact causes the present case not to be the normal situation—to wit, the hostile relationship of these two reluctant commercial partners...

...

As we observed earlier, there is an infinitude of practices affecting rates and service. The statutory directive must reasonably be read to require the recitation of only those practices that affect rates and service *significantly*, that are realistically *susceptible* of specification, and that are not so generally understood in any contractual arrangement as to render recitation superfluous.

The Commission has applied this rule of reason in addressing this issue, most recently concerning the Midwest ISO:

Under our existing ‘rule of reason’ policy, we see no reason to require that the Midwest ISO file the Business Practices Manuals. The Business Practices Manuals implicate our jurisdiction because, generally, they involve ‘the installation, operation, or use of facilities for the transmission or delivery of power...in interstate commerce.[’] [footnote omitted] However:

There is infinitude of practices affecting rates and service. The statutory

directive [of section 205(c)] must reasonably be read to require the recitation of only those practices that affect rates and services significantly, that are *realistically* susceptible of speculation, and that are not so generally understood as to render recitation superfluous... [footnote omitted]

... The Commission will not require a section 205 filing of the Business Practices Manuals because, while implicating our jurisdiction, they mostly involve general operating procedures. However, the Midwest ISO must make the documents available for public inspection on a permanent basis. We will require the Midwest ISO to revise the TEMT and any agreement on file with the Commission to the extent that they define rates, terms and conditions of service by reference to the Business Practices Manuals. Any reference to the specific rates, terms and conditions must be set forth in the TEMT and rate schedules as well.

Midwest Independent Transmission System Operator, 108 FERC ¶61,163 at PP 656, 658 (2004). The IRC believes the Commission's approach remains sound. The IRC members already post their operating practices and business rules that implement the provisions of their Commission-approved tariffs on their websites and review them with their stakeholders in their open stakeholder process. The Commission believes that this approach provides the best balance that provides the needed transparency without overburdening the Commission's approval process and the transmission operator's needed flexibility in changing these very specific operating practices. The Commission can apply its "rule of reason" to continue the RTO/ISO practices.

Moreover, the Commission has a basis to apply the *City of Cleveland* precedent to differentiate, if it so chooses, its application of its "rule of reason" between ISO/RTOs versus vertically integrated transmission providers. The *Cleveland* case noted (at 1376) the appropriateness of applying the "rule of reason" more strictly in a situation where

there is the potential for discrimination in the application of business practices. By definition, an ISO/RTO is an independent entity that is not a market participant so that the “rule of reason” can allow for continuation of the existing ISO/RTO practice of posting business practices without triggering concerns about the potential for undue discrimination.

I. Joint Transmission Planning

ISO/RTOs maintain a regional perspective that facilitates planning on a large scale, and ISO/RTOs work with stakeholders and each other to conduct holistic, integrated system planning. This process examines and evaluates all system drivers and potential solutions to identify the most efficient, effective means to meet the reliability and economic needs of the region(s). ISO/RTOs identify and resolve transmission constraints, generation and demand-side concerns, and other system problems, in order to promote robust competitive markets and reliable operations.

Most ISO/RTOs have an internal process to coordinate projects with their transmission owning members. Members are obligated to build projects needed for reliability, and in certain ISO/RTO footprints, they are also obligated to build projects upon a determination that they are needed for economic reasons.³⁴

ISO/RTOs’ regional planning has produced significant results:

- Between 1999 and 2004, PJM’s Regional Transmission Expansion Process has approved and directed more than \$1 billion in new transmission investments. Although load and transaction volumes have grown markedly over approximately the same period, these investments

³⁴ Independent observers have praised these processes for their comprehensiveness and depth. In a June 2004 study, *U.S. Transmission Capacity: Present Status and Future Prospects*, Eric Hirst reviewed 20 transmission plans, including those from ISOs, RTOs, regional reliability councils, utilities and transmission companies. Hirst concluded that the best planning documents included those prepared by the ISO-NE, MISO and ERCOT. *Id.* at 44.

have held PJM's congestion costs between 7 and 9 percent of total electricity costs, with only one percent of that congestion unhedged.³⁵

- Since the CAISO began its transmission planning role in 1998, it has approved \$3.32 billion in grid expansion projects. Upgrades to the southern California high voltage system alone in the past year have produced congestion savings of more than \$170 million in 2005 as compared to the same time period in 2004.
- Under ERCOT's planning regime, transmission owners in Texas have completed or have in development almost \$4.8 billion in new transmission investments.³⁶
- Since ISO-NE's commencement of regional planning in 2001, over 75 transmission projects have been placed in service, totaling over \$217 million in new construction investment. ISO-NE's current transmission plans call for an additional estimated transmission investment of \$2–4 billion. Although these projects comprise all types of transmission upgrades and replacement, the majority of that investment is in five major 345 kV projects throughout New England.
- MISO's 2005 transmission expansion plan identifies 615 planned or proposed transmission facility additions and enhancements, representing a total investment of \$2.9 billion through 2009.³⁷ The California ISO has approved \$3.32 billion in transmission upgrades.³⁸

A sum of greater than \$19.8 billion of new transmission investment has been built or planned in ISO/RTOs over the past five years, and the track for projects incorporated and analyzed within ISO/RTO regional plans shows a high probability of regulatory approval and completion. The Edison Electric Institute's 2005 Electric Transmission Capital Budget and Forecast Survey of investor-owned utility (IOU) transmission owners found that those IOUs within ISO/RTOs will contribute approximately 70 percent (\$19.8

³⁵ White Paper at 33.

³⁶ *Id.*

³⁷ *Id.*

³⁸ *Id.*

million in 2003 dollars) of planned investment to the grid between 2004 and 2008.³⁹ The Commission has recognized the contrast with utilities in areas lacking ISO/RTO markets⁴⁰ and a formal planning process.⁴¹

Given the existence of such processes, the Commission's fundamental goal of ensuring joint planning that incorporates generators and load needs as well as transmission owner requirements is largely achieved from a structural viewpoint. This does not mean that enough has been done in ISO/RTO areas, or in the rest of the nation, to spur new investment in transmission. The structure of the ISO/RTO planning process represents a foundational building block that can, coupled with other initiatives, such as incentive rates in order to achieve the desired level of infrastructure. The Commission should ensure that planning efforts in non-ISO/RTO areas work with adjacent ISO/RTO planning processes. The TVA/PJM/MISO⁴² and the NYISO/PJM/ISO-NE planning protocols provide two such examples.

J. Obligation to Expand Capacity

The IRC does not favor any blanket changes to ISO/RTO tariffs in this area.

K. Joint Ownership

The ISO/RTO structure accommodates joint ownership of transmission facilities because it does not accord different treatment to assets based on their ownership either in

³⁹ E-mail from Edison Electric Institute staff, July 2005.

⁴⁰ FERC 2004 State of the Market Report at 61.

⁴¹ *Id.* at 27.

⁴² Modeled after the PJM/MISO planning protocol, this three-way protocol provides for similar coordination of interconnection, transmission service requests and regional expansions plans. Such planning enables identification of cross-border loop-flow impacts of system developments and affords an opportunity to resolve these impacts in efficient and equitable ways.

the planning process or in the operation of the grid. Indeed, IRC members encourage joint ownership or a consortium approach as a means to involve multiple interests in the development of large and complex transmission projects. Moreover, ISO/RTO planning processes can serve to facilitate a coordinated approach to aging infrastructure issues, including maintaining an appropriate system-wide inventory of spare transformers and other major capital assets. Any reforms in this area should build on the existing collaborative processes in place through the ISO/RTO planning processes.

L. Tariff Compliance Reviews

To the extent the Commission undertakes tariff compliance reviews of all transmission providers, it may wish to initiate this process in non-ISO/RTO areas prior to devoting its resources to tariff compliance reviews in ISO/RTO areas. The level of transparency in an ISO/RTO is far greater than in a vertically integrated transmission provider and the motivations to discriminate are not present. All of the ISO/RTOs already undertake extensive SAS 70 audits, a process for evaluating the reasonableness and effectiveness of controls of a service organization to its user organizations. The IRC is not aware of any similarly rigorous process in place applicable to non-ISO/RTO transmission providers. Moreover, a number of the ISO/RTOs have market monitors in place whose role includes the ISO/RTOs compliance with its tariffs.

The Commission also should consider imposing less onerous compliance reviews on transmission owners that are members of ISO/RTOs in recognition of their participation in transparent processes administered by the ISO/RTO and given that they are subject to an additional level of scrutiny from the market monitoring function.

M. Hoarding of Transmission Capacity

ISO/RTOs are independent, and do not participate themselves in the markets they administer. Where LMP is used, hoarding is not feasible by anyone. ISO/RTOs using LMP continually provide, or provide the equivalent of, real-time Available Transmission Capacity and inter-system transfer capabilities in order to make maximum use of the transmission system subject to their control consistent with reliability. To “hold” transmission, a transmission customer must buy energy and deal with congestion costs. Even so, the availability of non-firm transmission to others still is limited practically by the amount that this customer is willing to pay for congestion. Thus, LMP effectively prevents the hoarding of concern to the Commission here. Moreover, even if it were possible for transmission customers to hoard capacity in the first instance, such behavior would be unlikely to escape notice by the market monitor.

N. Curtailments

Because ISO/RTOs are independent and their procedures for determining curtailments are transparent, the Commission’s concerns about transmission providers manipulating curtailments to unduly preference market affiliates do not apply to ISO/RTOs. Consequently, there is no reason to change the provisions concerning curtailments in the OATTs administered by ISO/RTOs in this proceeding.

O. Reservation Priority

These questions have no relevance to ISO/RTOs with organized markets. In the LMP model used by ISO/RTOs, assuming no system reliability issues arise, transmission comes automatically with all transactions that clear the market subject only to a transmission customer’s willingness to pay for the costs of any associated congestion.

Customers may hedge these costs through participation in markets for the relevant financial products. Consequently, the operation of the market rather than a scramble for a place in the queue apportions scarce supply of transmission capacity.

P. Designation of Network Resources

These questions have no relevance for ISO/RTOs with organized markets. An ISO/RTO that offers financial reservation-based transmission service in the form of “network service” evaluates all requests for transmission service, regardless of whether it is associated with a generator, in the same manner as requests for point-to-point service. The process is transparent, as it appears on OASIS, and affords no opportunity for discrimination. ISO/RTOs, of course, have no affiliates for whom they would seek to preserve advantage. Nor is there any opportunity here for a transmission owner with affiliated generation to interfere at this stage of the interconnection process.

Q. Queuing for Long-Term Transmission Service

The IRC regards the issues raised in this area as inapplicable to ISO/RTOs. In most ISO/RTOs, generators enter a queue for interconnection and receive FTRs as an offset for their funding the cost of upgrades. Since service is arranged financially rather than physically, a variety of hedging tools, such as FTRs and Auction Revenue Rights are available to ensure long-term access to the transmission grid. Consistent with the Energy Policy Act of 2005, the ISO/RTOs are committed to working with the Commission on a longer term FTR product.

R. Ancillary Services

The Commission correctly identified the ancillary services common to most electric grids in Order No. 888. The IRC does not support altering the existing services

or establishing new ones on a pro forma basis. The need for and price of additional services should be determined by the ISO/RTO and the market participants in accordance with their particular circumstances. Also, although IRC members prefer and have implemented market-based approaches to ancillary services, and may have additional ancillary services than those provided for under Order No. 888, this preference should be weighed against the physical realities of the particular service and its impact on the potential exercise of market power. A good example is the need for reactive power, which, because it must be provided locally, raises market power issues that need to be addressed in any market design.

S. Pro Forma OATT Definitions

As the IRC previously noted in its comments provided in response to the Commission's inquiry concerning the standardization of Available Transfer Capability, standard definitions as devised by the Commission in that proceeding for "Available Transfer Capacity (ATC)", "Available Flowgate Capacity (AFC)", "Capacity Benefit Margin (CBM)" and "Transmission Reliability Margin (TRM)" would be helpful. This could be accomplished in part through the vehicle of OATT reform.⁴³

T. ISO, RTO and ITO and ITC Tariffs

The Commission's questions in this area suggest a recognition that the fundamentally independent and transparent structures of ISO/RTOs may obviate the need for significant changes to their tariffs through this proceeding. As discussed above, the ISO/RTO paradigm fully addresses the Commission's concerns regarding unduly

⁴³ Comments of the ISO/RTO Council, *Information Requirements for Available Transfer Capability*, Docket No. RM05-17-000, filed August 15, 2005.

discriminatory and preferential practices. The Commission should refrain from making unnecessary sweeping changes to ISO/RTO tariffs because there are significant costs associated with such disruption. For example, investor confidence in the stability of the rules governing ISO/RTO markets is crucial the long-term viability of those markets.

ISO/RTOs are ready to move beyond the issues confronted by the Commission in Order No. 888. Each confronts difficult challenges, and they have risen to meet them in proceedings now pending before this Commission. The agenda for ISO/RTOs includes developing markets that send efficient signals, encouraging new investment in infrastructure appropriate for competitive regional wholesale energy markets, adapting the available regulatory and monitoring tools to ensure orderly markets, and the continual fine tuning of ISO/RTO designs to improve their internal efficiency and efficient exchanges among themselves. The IRC supports the Commission's effort in this proceeding to address the uneven progress towards realization of the important goals the Commission set forth in Order No. 888 for reforming the nation's energy regulatory policies. We urge, however, that the Commission allow the momentum toward achieving its objectives of open, non-discriminatory access that has developed in ISO/RTO areas to continue and not slow that momentum in its important and timely efforts to address problems in areas without such structures.

III. Conclusion

The IRC asks that the Commission consider these Comments and avoid supplanting individual stakeholder processes or changing already approved market designs arising from those processes in this docket. The IRC stands ready to work with

the Commission on those issues which may need further development in individual ISO/RTO dockets as a result of Commission action pursuant to this Notice.

Respectfully submitted,

/s/Craig Glazer & Jeffrey Mayes

Craig Glazer
Vice President–Federal Government Policy
Jeffrey W. Mayes
Senior Counsel
PJM Interconnection, L.L.C.
1200 G Street, N.W., Suite 600
Washington, D.C. 20005

/s/Steven Kozey

Steven G. Kozey
Vice President and General Counsel
Midwest Independent Transmission
System Operator, Inc.
701 City Center Drive
Carmel, Indiana 46032

/s/Matthew Goldberg

Matthew F. Goldberg
Senior Regulatory Counsel
ISO New England Inc.
One Sullivan Road
Holyoke, Massachusetts 01040

/s/Anthony Ivancovich

Charles Robinson
Vice President and General Counsel
Anthony Ivancovich
Assistant General Counsel–Regulatory
California Independent System
Operator Corporation
151 Blue Ravine Road
Folsom, California 95630

/s/Kim Warren

Kim Warren
Manager, Regulatory Affairs
Independent Electricity System
Operator of Ontario
655 Bay Street, Suite 410
Toronto, Ontario, MSG-2K4 Canada

/s/Robert Fernandez

Robert E. Fernandez
Vice President and General Counsel
New York Independent System Operator, Inc.
290 Washington Avenue Extension
Albany, N.Y. 12203

/s/Stacey Duckett

Stacey Duckett
General Counsel & Corporate Secretary
Southwest Power Pool
415 North McKinley
#140, Plaza West
Little Rock, Arkansas 72205-3020

Dated: November 22, 2005

The Value of Independent Regional Grid Operators

*a report by
the ISO/RTO Council*

November 2005

ISO/RTO COUNCIL

"Promoting communication, providing mutual assistance, developing effective processes and tools, and coordinating in areas of mutual consent."

Independent Electricity System Operator, ISO-New England, California ISO, New York Independent System Operator, Southwest Power Pool, The Electricity Reliability Council of Texas, Inc., Alberta Electric System Operator, PJM Interconnection, Midwest Independent System Operator

November 14, 2005

The ISO/RTO Council (IRC) is an industry organization that includes the seven Independent System Operators (ISOs) and Regional Transmission Organizations (RTOs) responsible for delivering two-thirds of the electricity consumed in the United States to two-thirds of its population. The Council has recently completed the enclosed report highlighting the value of independent regional grid operators.

This paper explains the core functions and key benefits of ISOs and RTOs. It notes many of the financial benefits of increased reliability and more efficient use of the grid, reduced reserve requirements, and coordinated planning for new generation and transmission resources.

We hope this document will create greater awareness of the functions ISOs/RTOs perform and the value they deliver. We trust you will find it useful and informative.

Sincerely,



James P. Torgerson
Chairman, ISO/RTO Council



The Value of Independent Regional Grid Operators

TABLE OF CONTENTS

EXECUTIVE SUMMARY	7
1 Introduction	9
Information availability.....	10
2 ISO/RTOs maintain and improve grid reliability	11
Grid management is more complex	11
Coordination is essential	13
Sophisticated tools and training	14
Advanced physical infrastructure for grid reliability	17
Operator staffing and training	18
3 ISO/RTOs improve operating efficiencies	19
Elimination of pancaked rates.....	21
Efficiency improvements from RTO-facilitated competition	23
4 ISO/RTOs operate markets that lower customer energy costs	24
Savings from organized markets.....	25
Price transparency has value	26
Market liquidity.....	27
Risk management.....	28
Market monitoring	29
Challenges ahead.....	29
5 ISO/RTOs provide fair, independent and open markets and transmission access	30
Demand response growing in ISO/RTOs.....	31
6 ISO/RTOs provide effective regional planning	32
Economic transmission projects.....	33
Regional system planning works	34
Cost certainty enhances grid investment.....	35
Generation interconnection	36
7 RTO costs flatten with size and experience	36
ISO/RTO cost factors	39
ISO/RTO cost management.....	41
Challenges ahead.....	42
8 Conclusions	42
APPENDIX A - ISO/RTO COST DETAILS	43

The Value of Independent Regional Grid Operators

EXECUTIVE SUMMARY

In the 1990s, as states and regions within the United States established wholesale competition for electricity, groups of utilities and their federal and state regulators began forming independent, unbiased transmission operators to ensure equal access to the power grid for new, non-utility competitors. Today, the seven Independent System Operators and Regional Transmission Organizations (ISO/RTOs) in the United States coordinate reliable power grid operations for two-thirds of its population and two-thirds of its electric generation.¹

ISO/RTOs coordinate generation and transmission across a wide geographic area, matching generation instantaneously to the demand for electricity. They forecast load and schedule generation to assure that sufficient generation and back-up power is available in case demand rises or a power plant or power line is lost. ISO/RTOs are improving grid reliability and driving innovation in grid management technology and effectiveness, including data visualization for system operators, faster contingency analysis and data interpretation, and cyber-security protection measures. The result is an offering of extensive services and value to all participants, including those who previously had little grid or market access.

ISO/RTOs perform more than the traditional duties of transmission utilities or control areas. They provide many new, more extensive grid reliability services and transaction support services that didn't exist previously. ISO/RTOs provide non-discriminatory transmission access, facilitating competition among wholesale suppliers to improve transmission service and provide fair electricity prices. The range and quality of services they provide – regional planning, energy and/or capacity market operation, outage coordination, transactions settlement, billing and collections, risk management, ancillary services, credit risk management, and more – has broadened significantly in recent years. Across large regions, they schedule the use of transmission lines; manage the interconnection of new generation without any possible conflict of interest; and provide or support market monitoring services to ensure fair and neutral market operations for all participants. Providing these services regionally offers superior value to grid users relative to providing them on a smaller-scale, utility-by-utility.

Today's power industry is far more than a collection of power plants and transmission lines. Maintaining an effective grid requires management of three different but related sets of flows – the flow of energy across the grid; the exchange of information about power flows and the equipment it moves across; and the flow of money between producers, marketers, transmission owners, buyers, and others. ISO/RTOs play essential roles in managing and improving all three of these flows. This paper shows that ISO/RTOs play a critical, necessary and unprecedented role in the nation's electric grid and offer significant benefits for a limited cost, including:

- Grid reliability, where they perform many sophisticated, information technology-intensive tasks to manage a highly interdependent and complex grid;
- Improved operating efficiencies, including seams coordination, market-based congestion management processes, and the elimination of multiple charges for transmission service;
- Regional planning, which take a broad analytical approach to intra- and inter-regional infrastructure expansion for reliability and economic improvement;
- Open markets and transmission access that are managed in a fair and independent manner; and
- Market operations that lower consumer energy costs.

¹In the United States, ISOs are single-state or multiple-state entities established under Order 888 of the Federal Energy Regulatory Commission. RTOs perform similar or expanded services across a multi-state area, and have been approved by the FERC as meeting the requirements of FERC Orders 2000 and 2001.

The Value of Independent Regional Grid Operators

The paper also reviews the costs of operating ISO/RTOs. It shows that those costs are related to the number of services they provide and that as ISO/RTOs mature, their costs stabilize or fall with the growth in the amount of load served. The paper also discusses several of the factors that drive ISO/RTO costs.

This study shows that ISO/RTOs provide a wide variety of high-value services that cannot be performed by smaller, less sophisticated organizations. Finally, it concludes that the total value of these services and the savings and efficiencies they bring to America's electricity markets far exceeds the funds that ISO/RTOs expend to provide these services.

1 Introduction

Two-thirds of Americans live in regions served by Regional Transmission Organizations (RTOs) and Independent System Operators (ISOs).² In 2004 ISO/RTOs delivered 2.19 million gigawatt hours (GWh) of electricity – 62 percent of the electricity consumed in the U.S. – and 58 percent of the peak load. They oversee more than 272,000 miles of high-voltage transmission lines and coordinate power production from 585,000 megawatts (MW) of generation (67 percent of the U.S. total).

The Federal Energy Regulatory Commission (FERC) proposed ISOs in 1996, in response to the Energy Policy Act of 1992. FERC's Order 888 allowed the creation of ISOs to consolidate and manage the operation of transmission facilities to provide open, non-discriminatory transmission service for all generators and transmission customers. In Order 2000, FERC officially endorsed the role of RTOs to oversee electric transmission and operate wholesale markets across a broad territory.

ISO/RTOs are independent entities, unaffiliated with any market participant, that serve large regions of the grid. Their many functions include day-to-day grid operations, long-term regional planning, billing and settlements, and various wholesale electric market services. RTOs are recognized by FERC as fulfilling the requirements laid out in Order 2000; ISOs perform equivalent services but tend to be smaller in geographic size, or are not subject to FERC jurisdiction (as in Canada and central Texas).

There are nine ISO/RTOs in the United States and Canada:

- Alberta Electric System Operator (AESO, an ISO);
- California Independent System Operator (California ISO);
- Electric Reliability Council of Texas (ERCOT, an ISO);
- Ontario's Independent Electricity System Operator (IESO, an ISO);
- ISO New England (ISO-NE, an RTO);
- Midwest Independent Transmission System Operator (Midwest ISO, an RTO);
- New York Independent System Operator (NYISO);
- PJM Interconnection (PJM, an RTO); and
- Southwest Power Pool (SPP, an RTO).

ISO/RTOs delivered 2.19 million GWh of electricity – 62 percent of the electricity consumed in the U.S. – and 58 percent of the peak load.

²In the United States, ISOs are single-state or multiple-state entities established under Order 888 of the Federal Energy Regulatory Commission. RTOs perform similar or expanded services across a multi-state area, and have been approved by FERC as meeting the requirements of FERC Orders 2000 and 2001. This white paper is a U.S. - focused report and, as such, does not include data and other information from Canadian members of the ISO/RTO Council (IESO and AESO).

One of the most important responsibilities of ISO/RTOs is to make information transparent and available to all market participants and stakeholders.

Figure 1 —
Map of
Existing and
Proposed ISO/
RTOs

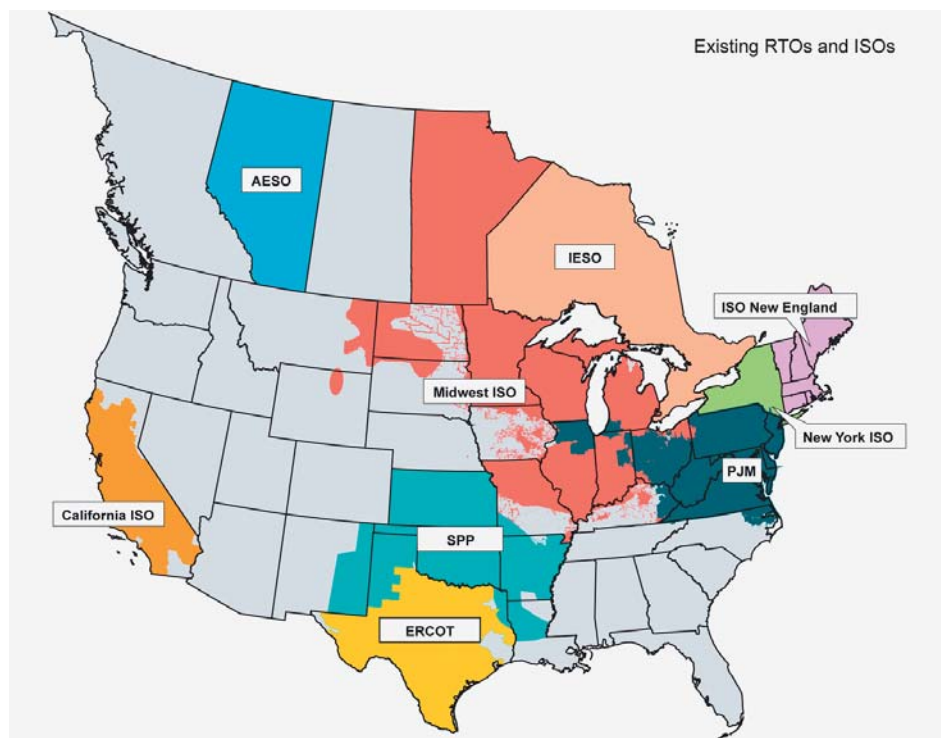

Information availability

While this report describes many of the accomplishments and activities of ISO/RTOs, it offers few comparisons to areas that do not host an ISO or RTO. Detailed comparisons between the areas organized into ISO/RTOs and other portions of the nation are impossible because there is very little systematic, comparable, detailed data on the non-organized regions. The problem of insufficient and inconsistent data on transmission infrastructure, grid operations and market transactions has been documented by sources including the Energy Information Administration and the Edison Electric Institute.³

ISO/RTOs document and quantify every aspect of their activities – costs, prices, transactions, loads, demand response, new investment, and more – because one of their most important tasks is to make information transparent and available to all market participants and stakeholders. But no comparable documentation exists among the diverse investor-owned utilities, federal power agencies, generation and transmission cooperatives, distribution cooperatives, municipal power companies, and others that make up the electric power industry outside ISO/RTO footprints. There are few regulatory requirements for information collection about these entities, and government or industry initiatives have produced little useful information. Therefore, while it is possible to collect and compare costs and accomplishments for the ISO/RTOs and their members, the costs and accomplishments in the rest of the nation are relatively undocumented and are difficult, if not impossible, to collect.

³See, for example, Energy Information Administration, “Electricity Transmission in a Restructured Industry: Data Needs for Public Policy Analysis,” December 2004, and Energy Security Analysis, Inc., for Edison Electric Institute, “Meeting U.S. Transmission Needs,” July 2005.

2 ISO/RTOs maintain and improve grid reliability

Unlike other commodities, electricity generally cannot be stored for later use; it must be used as it is generated. Therefore, generation must be dispatched instantaneously to respond to real-time changes in consumers' demand for electricity. To support these energy flows, grid operation encompasses scheduling and managing flows over transmission lines and coordinating the operation of the transmission network equipment.

All grid operators are charged with maintaining the reliability of the systems under their control. Within their footprints, ISO/RTOs oversee and direct the high-voltage, bulk power system and coordinate electricity generation to maintain a reliable supply of electric power to electricity users. ISO/RTOs provide critical reliability services including outage coordination, generation scheduling, voltage management, ancillary services provision, load forecasting, and more. They improve reliability in part because of their large scope – by consolidating control areas, they reduce the number of decision makers managing the grid, which simplifies coordination and improves reliability.

ISO/RTOs use complex computer models to analyze the real-time state of electrical flows on the grid and identify potential problems. ISO/RTO system operators oversee grid functions and make necessary corrections to ensure reliability on a minute-to-minute basis, around the clock. ISO/RTOs may offer wholesale markets for energy and ancillary services, such as reserves, frequency and voltage regulation, and voltage support. These ancillary services help ensure reliability and help system operators react quickly and effectively to changing conditions on the grid, such as the loss of a generating unit or a transmission line.

ISO/RTOs' scale of operations allows them to see a broader picture of grid conditions than the typical, smaller, stand-alone grid operator. Because of their "big picture" view, they are better positioned to detect developing problems on the grid. Because of their scope and sophistication, they have increased flexibility to respond to the situations they detect. In the event of a system emergency, the ISO/RTO is the central authority within its footprint, determining what actions transmission and generation owners should take to protect the grid.

As part of grid operations, ISO/RTOs meet or exceed the reliability standards set by the North American Electric Reliability Council (NERC) and its regional councils. Adhering to NERC standards ensures that the entire grid in North America operates at appropriate levels of reliability. All ISO/RTOs are members of NERC and participate in regional reliability councils. SPP and ERCOT also serve as NERC reliability councils on behalf of their control areas

Grid management is more complex

Grid management has become notably more complex over the past decades.

Between 1980 and 2002:

- Non-coincident peak load grew 67 percent, from 427,058 to 714,565 GW;
- Generation capacity grew 49 percent, from 572,195 to 850,984 GW;

The Value of Independent Regional Grid Operators

- Total electricity consumption per year grew 75 percent, from 2,094 to 3,660 billion kilowatt hours (KWh); and
- Net generation per year grew 68 percent, from 2,286 to 3,839 billion KWh.⁴

The level of grid usage increased markedly in every region. High asset utilization is a good thing in principle because it means that resources are being used cost-effectively. However, consistently high utilization of critical assets in a network often means that those assets have become bottlenecks limiting the use of the network and its ability to serve demands at every level consistently and reliably. These points on the grid create transmission constraints. In some cases they create congestion by limiting buyers' ability to secure energy from the most economical source, necessitating purchase from closer, more costly generators. In other cases, transmission constraints such as Path 26 in Southern California, southwest Connecticut, or those in Wisconsin and Michigan's upper peninsula can cause a reliability problem when customer demands exceed transmission system delivery capabilities plus local generation.

New transmission investments can have a critical impact on grid operations. The California ISO worked with utilities to upgrade three major weak links in the Southern California portion of its grid, adding more than 1,000 MWs in extra capacity just in time to relieve bottlenecks during record demand in summer 2005. The projects – the Path 26 upgrade, the South of Lugo upgrade serving the Los Angeles Basin, and the Miguel-Mission Line near San Diego – have helped lower costs for customers by delivering more low-cost electricity to southern California customers, reducing congestion costs by more than \$170 million in the first eight months of 2005.

Many of the most heavily loaded points on the North American grid exist near the interfaces between two control areas,⁵ where two utility transmission systems meet. These heavy loadings reflect the historical reality that each utility planned and invested in transmission to meet its internal needs, and did not look or spend money beyond its service area, even as it increasingly relied on imports for low-cost energy to meet native load needs. This was true operationally as well – most utilities only monitored grid conditions within their own footprints, and controlled their own facilities and no others with limited coordination and communication beyond those boundaries.

With increasing power flows over a grid with rapidly changing electrical topologies, the local utility was no longer able to see and manage every factor affecting the flows upon its share of the transmission grid. The scope of grid monitoring and control that worked effectively in the days of high capacity margins and limited inter-utility flows were no longer sufficient. As it became more clear in the 1990s that higher grid usage was causing greater reliability challenges, policy-makers and utilities determined that increasing the size of grid oversight and control organizations was the only effective way to deal with these challenges. ISO/RTOs have the size, scope, scale, tools, information and authority to be more effective grid managers than the smaller control areas that once performed these tasks for smaller loads with local generation and limited interconnections.

⁴United States Statistical Abstract, 1995 and 2004 editions, Energy chapters.

⁵A control area is an electric power system that is managed under a common automatic control scheme that maintains frequency by balancing load with production. Historically, a utility ran its own control area, regulating frequency, balancing its load to owned generation and purchased energy and capacity, and maintaining operating reserves as needed. Many large utility control areas served smaller in-area and near-by utilities as well. Today, some control areas exist to manage only generation, but most balance both generation and load. Many control areas that existed historically have been consolidated as ISO/RTOs and offered system balancing and management services that the control area no longer had to self-provide.

Coordination is essential

The ability to monitor and understand the grid across wide regions is crucial for grid optimization and flow management. Every part of the interconnected grid can be affected by conditions at distant nodes, and electrical events that threaten reliability can occur with little or no warning. Therefore, ISO/RTOs have worked aggressively and cooperatively to expand their understanding of grid conditions within and beyond their service areas, and to remove any obstacles to either operational reliability or the flow of market transactions.

Some of the measures ISO/RTOs have taken to improve grid visibility and cooperative management include:

- Developing coordination agreements and market-based congestion management processes between each ISO/RTO and its neighbors, addressing data exchanges, compatible flow, transaction and market scheduling, improved communications protocols, emergency power transfers, and more, to give each other an unobstructed view into the neighbor's footprint. One example is the Midwest ISO, PJM and the Tennessee Valley Authority (TVA) Joint Reliability Coordination Agreement, that provides for comprehensive reliability management and congestion relief within the three power systems, which together serve over a third of the nation.
- Working with Energy Management System (EMS) software vendors to develop common protocols and formats for grid and transactions information, to assure effective and accurate communications and data comprehension.
- Working with the U.S. Department of Energy to implement the Eastern Interconnection Phasor Project, a grid monitoring system that will provide consistent, detailed information on reliability conditions and metrics across the entire eastern grid. Similar monitoring is being undertaken in California.
- PJM, NYISO, IESO, and utilities in the Midwest developed the Lake Erie Emergency Redispatch Agreement to deal with loop flows on transmission around Lake Erie. Unscheduled loop flows can limit throughput on transmission lines, cause congestion, and threaten reliability. Under the redispatch agreement and related agreements, the RTOs and their partners will coordinate between all affected transmission owners and reliability coordinators to monitor and analyze grid conditions and loop flows, mitigate the flows as necessary, and coordinate emergency redispatch when needed to avoid cutting customer loads.
- Given their role as information hubs for grid and market data, the ISO/RTOs were leaders of the effort to develop cyber-security guidelines and standards to protect industry information and management hardware and software tools and equipment. Their efforts culminated in the adoption of the first voluntary cyber-security standard adopted in any industry.
- NYISO, ISO-NE and PJM have signed a gas operations coordination agreement to assure that potential natural gas problems do not compromise electric reliability. Because the northeast has a high proportion of gas-fired electric generation, the three regions will share information and coordinate operations in the event of cold weather or abnormal natural gas supply or delivery conditions.
- ISO-NE, NYISO and IESO have implemented a facilitated check-out process that shares information on every transmission transaction between the three grid operators, to ensure that every transaction is scheduled and accepted across all three systems.
- SPP works with ERCOT and western utilities to coordinate operations over the direct current (DC) ties that connect the eastern and Texas interconnections, including market to non-market coordination between ERCOT and SPP.

ISO/RTOs have worked aggressively and cooperatively to expand their understanding of grid conditions within and beyond their service areas.

It is feasible to develop and implement such coordination and sharing agreements because there are a limited number of ISO/RTOs, each performing near-identical responsibilities over a large geographic scope. NERC reports that after the formation of ISO/RTOs and the consolidation of many of the control areas associated with ISO/RTO development, there are currently 130 control areas in North America. Thirty-three of these are in areas served by ISO/RTOs; the remaining 97 serve the remainder of the country. It would be difficult to develop comparable agreements between control areas because the number of control areas and their generally limited level of resources make it prohibitively difficult to negotiate and implement comparable measures at that level.

The independent status of ISO/RTOs facilitates development of coordination and information sharing agreements, because the ISO/RTO can act as an objective broker and facilitator, and no market participant has to fear that the ISO/RTO will misuse its private information. The ISO/RTO can bring together all stakeholders across a broad geographic region to address challenging issues. As an example, the comprehensive congestion management processes implemented in recent seams agreements required allocation of the existing capacity on transmission system facilities. Because they do not own transmission assets but coordinate transmission services, the ISO/RTOs were able to do critical data compilation and grid capacity calculations and propose and facilitate agreements on these complex allocation issues.

Sophisticated tools and training

Effective reliability software and communications methods are crucial to effective grid management. Grid operators use extensive software to manage the grid and operate markets. Table 1, developed by Gestalt LLC, lists and describes these applications. Gestalt explains that the nine market administration applications – which include meter data acquisition (A14), settlement (A13) and billing (A12), functions that are needed for non-market tariff administration as well as market management – stand upon a foundation of grid management and reliability coordination tasks. Therefore, the 10 applications used for short-term system reliability provision – five for open transmission access, and two suites used for market monitoring and transmission planning applications – represent the bulk of ISO/RTO software uses.

Some of the software used by ISO/RTOs performs the same function as that used by control areas. However, the ISO/RTOs use software that works on a wider scale and higher level of technical sophistication, to suit the ISO/RTOs' wider responsibilities and more challenging tasks.

The large footprints of ISO/RTOs, as well as the vast amounts of energy they manage, give them the resources to fund and maintain these powerful tools, spreading the costs over a large number of users in a highly cost-effective way.

ISOs' and RTOs' large footprints, as well as the vast amounts of energy they manage, give them the resources to fund and maintain powerful reliability tools, spreading the costs over a large number of users in a highly cost-effective way.

Table 1
Power System Operations Applications and Descriptions

FERC IT Guidelines Project - ISO/RTO Applications			
	Appl#	Application Name	Function
Open Access Transmission Service Applications	A01	External Transaction Scheduler	Used to schedule external transactions, including through and out transactions.
	A02	Open Access Same Time Information System	Management of transmission service requests
	A03	Total Transfer Capability (TTC) Calculator	Analysis package that calculates transmission system import/export capability between control areas.
	A04	Available Transfer Capability (ATC)	Analysis package that adjusts TTC to account for confirmed transmission reservations.
	A05	Transmission Tariff Settlement System	Calculation of Tariff charges/credits
Market Applications	A06	Participant Bidding System	Offer/Bid processing including submission of internal bilateral transactions (financial schedules);
	A07	Day-Ahead SCUC/SCED - LMP	Security Constrained Day-Ahead unit commitment and economic dispatch with LMP market clearing calculations.
	A08	Real-Time SCED - LMP	Generate dispatch instructions on a 5 minute basis utilizing security constrained Optimal Power Flow (OPF). Calculate real-time LMPs.
	A09	FTR Auction System	FTR Auctions, Simultaneous Feasibility Test system.
	A10	Ancillary Service Auction System	Market clearing for regulation, operating reserves, installed capacity
	A11	Customer Service, Credit & Registration	Customer service, asset registration & credit management systems
	A12	Billing System	Invoicing and Funds transfer. Daily/weekly/ monthly billing system
	A13	Market Settlement	Commercial model, settlement calculations
	A14	Meter Data Acquisition	Data acquisition, verification and error reporting.
Short-Term Transmission System Reliability Applications	A15	Energy Management System (EMS)	SCADA system, State estimator, Network Model, AGC, VAR/voltage control, Reserve Monitor (real and reactive).
	A16	Dynamic Scheduling System	System that enables the calculation of dynamic schedules for use by control areas under the RTO footprint. Requires RTO EMS to CA EMS link to update tie-schedules such that updated CA tie schedules are included in ACE calculation.
	A17	Day Ahead SCUC/SCED	Security constrained unit commitment and reliability assessment tool. Need to perform Security Coordination duties. Market clearing function not included.
	A18	Network Analysis Package	Contingency Analysis, Optimal Power Flow, Stability Analysis. Includes power flow for use in study mode.
	A19	Real-Time security constrained economic dispatch.	Generate dispatch instructions on a 5 minute basis utilizing security constrained Optimal Power Flow (OPF).
	A20	RCIS	Reliability Coordinator Information System - allows for easy transfer of data between Reliability Coordinators. Provides input to IDC.
	A21	Interchange Distribution Calculator (IDC)	Automatically calculates transaction flow distribution on monitoring transmission interface. Needed for implementation of NERC TLR procedures.
	A22	Outage Scheduler	Coordinate generation and transmission planned outages and record and track generator forced outages
	A23	Load Forecasting	Load forecasting suite with integrated weather forecast inputs.
	A24	Dispatcher Training Simulator (DTS)	Redundant EMS for use in training system operators.
Market Monitoring	A25	IMM	Independent market monitoring and mitigation
Trans Plan	A26	Transmission Planning Analysis Suite	Long Term load forecasting, power flow (PSS/E), stability analysis, short circuit analysis.
Corporate Admin. Applications	A27	Compensation & Benefits	Payroll & Benefits software
	A28	Human Resources	HR System
	A29	Customer Information	Customer Information and Relationship management
	A30	Accounting	Accounting System including: GL, Accounts Receivable/Payable, fixed assets, treasury, purchasing, budgeting, time reporting.

Source: Gestalt LLC, "Information Technology Guidelines for Power System Organizations" April, 2005, p. 39, available at www.ferc.gov.

The Value of Independent Regional Grid Operators

ISO/RTOs meet enhanced reliability requirements because they are dictating and driving development of more sophisticated grid management software and raising the bar for reliability and market performance capabilities.

In a FERC technical conference on information technology for reliability and markets, Dr. Frank Macedo, a consultant to FERC, offered a list of best practices and minimum requirements for reliability software. His list and conclusions, which are now being used in a reliability tools study by NERC’s Operations Committee, reviewed critical reliability tools such as network analysis capabilities (e.g. contingency analysis and state estimator tools), monitoring (energy management systems and SCADA (supervisory control and data acquisition systems), and real-time enablers (alarm processing, block load shedding, back-up facilities). They also use operations support tools such as season-ahead, day-ahead and hour-ahead system planning.⁶

As Table 2 shows, most of the ISO/RTOs have IT systems that meet Dr. Macedo’s criteria for “best practices” reliability tools, that facilitate and sustain reliable grid operations day in and day out. Every ISO/RTO has reliability tools that meet or greatly exceed the minimum standards. For example, the Midwest ISO’s real-time contingency analysis program uses up-to-date data on grid conditions and reviews 8,500 possible contingencies in and around its region every three minutes to understand potential problems and prevent or mitigate them.

Table 2
Evaluation of ISO/RTO Reliability Tools Against FERC-Identified Best Practices

Reliability Tools	CAISO	SPP	ISONE	Midwest ISO	PJM	ERCOT	NYISO
Network Analysis	P	P	P	B	P	B	B
Monitoring & Visualization	B	B	B	B	B	B	B
Real Time Enablers	B	M	B	B	B	P	B
Operations Planning	P	M	B	B	B	B	B
Transactions Scheduling	P	P	B	B	B	B	B
History & Forecasting	B	M	B	B	B	P	B
Best Practice = B Partial Best Practice = P Minimum Standard = M							
Source: ISO/RTO data, July 2005							

By contrast, NERC’s reliability readiness reviews, conducted for all reliability coordinators (including all ISO/RTOs) and many control areas since early 2004, indicate that many control areas have reliability tools that are closer to the minimum standard than the best practice capabilities – if they have the tools at all.⁷ For instance, a number of control areas lack functioning state estimators or real-time contingency analysis tools that meet Dr. Macedo’s minimum standards, so they do not have broad visibility and understanding of the grid.

ISO/RTOs meet these enhanced reliability requirements in large part because they are dictating and driving development of more sophisticated grid management software and raising the bar for reliability and market performance capabilities. The large geographic size of regions like PJM and Midwest ISO necessitate

⁶Dr. Frank Macedo, “Reliability Software – Minimum requirements and best practices,” with additional detail in a companion presentation, both presented at the FERC July 14, 2004 technical conference on Information Technology for Reliability and Markets, available at <http://www.ferc.gov/EventCalendar/EventDetails.aspx?ID=1102&CalType=%20&Date=7%2f14%2f2004&CalendarID=0>.
⁷NERC reliability readiness reviews are posted at <http://www.nerc.com/~rap/index.html>.

management tools that are scaled to cover more nodes and transactions than ever before. In addition, the ISO/RTOs' high demands for real-time reliability call for faster solution times with higher accuracy and precision than ever before. The ISO/RTOs have been working closely with IT vendors for the past decade to conceptualize, develop, test and perfect these new tools. Once the resulting products are proven within the ISO/RTO service areas, these enhanced reliability tools are being offered and purchased for use in control area operations outside ISO/RTO areas.

Table 3 shows the scope of the regions that ISO/RTOs are monitoring and analyzing for real-time reliability management. The table tallies the number of grid elements such as generators, transformers, and other SCADA/EMS points each grid operator monitors and models. In every case, the number of points monitored extends well beyond the ISO/RTO's service area to assure that it has effective visibility within and beyond its borders.

Number of Items Monitored	CAISO	SPP	ISONE	Midwest ISO	PJM	ERCOT	NYISO
Generators	1,500	966	662	1,511	1,167	583	1,500
Buses	1,600	12,600	1,700	13,773	12,735	4,860	3,360
Miles of Line	25,529	36,800	8,454	97,000	56,070	37,770	10,775
Transformers Monitored	565	888	500	4,258	5,571	1,500	1,110
Buses Monitored	2,200	2,027	1,300	18,258	7,052	4,860	1,173
SCADA/EMS points	72,000	38,000	17,000	44,320	68,036	54,750	18,382

Source: ISO/RTO data, July 2005

With all key points on the grid monitored, the grid operator uses the reliability tools discussed above to be sure grid conditions are safe and understand what might go wrong. For example, ISO-NE has developed and implemented real-time interface limit calculation software to let system operators calculate real-time first and second contingency transfer limits for thermal, voltage and stability conditions. ISO-NE compares real-time grid conditions against 1,000 specified system contingencies and models and checks every one in real-time and day-ahead in its security-constrained economic dispatch calculations. Doing this as an automated process for the day-ahead market has minimized manual interventions to commit power plants, produced more reliable and secure operational schedules with lower energy costs, and reduced execution time by as much as 40 percent.

Advanced physical infrastructure for grid reliability

ISO/RTOs use advanced information technology hardware and software to protect regional reliability. All of the ISO/RTOs use a combination of public and private communications networks with extensive cyber-security protections to send and receive data between monitoring points and control devices. PJM, for example, sends and receives approximately 25 terabytes of data every two to four seconds in network monitoring and management across its 13-state footprint. The communications networks are extensive – the California ISO, for example, uses a 4,500-mile-long private communications network that spans most of the state of California.

Each ISO/RTO has fully redundant computer systems if anything happens to the primary system, and has a back-up control room that can be activated quickly if anything happens to the primary facility.

Grid operators use the reliability tools discussed above to assess activity on the grid and ensure its safe and reliable operation. These can include primary control rooms with extensive, dynamic map boards and visualization tools. Each ISO/RTO has fully redundant computer systems to fill in if anything happens to the primary system, and has a back-up control room that can be activated quickly if anything happens to the primary facility.

Many transmission equipment elements, such as transformers, are highly specialized, time-consuming and costly to replace. PJM is working with its members to develop a coordinated program to replace transformers that are near the end of their useful lives and to develop standard transformer designs for some replacement transformers. The program would reap significant savings by combining buying power across multiple equipment owners, and the greater interchangeability of transformers means lower inventory costs and faster equipment replacement. Farther north, ISO-NE is working with New England stakeholders to develop a strategic spare parts inventory of critical transmission equipment the region can use to deal cost-effectively with equipment failures and maintenance needs.

Operator staffing and training

ISO/RTOs make a greater commitment to operator staffing and training than many transmission owners and control areas. Reliable grid operations require adequate staffs of highly trained, expert operators who can quickly evaluate the information before them about current grid conditions and possible threats to grid reliability, and make near-instant decisions about actions necessary to protect the grid. This is not possible without significant investments in recruiting and training a large corps of highly skilled operators and support staff (including supervisors, near-term system planners and information technology support staff).

ISO/RTOs systems operators run two or three shifts all day, every day, with five to 13 individuals in the control room on every shift. While one complement is on duty in the control room, another group is either on leave or undergoing training. As Figure 2 shows, ISO/RTO grid operators receive an average of 135 hours of training per year in everything from how to operate new equipment and software to how to recognize and manage system emergencies. Looking ahead, the NERC Personnel Certification Training

Figure 2 —
Operator Training at ISO/RTOs

Source:
ISO and RTO data

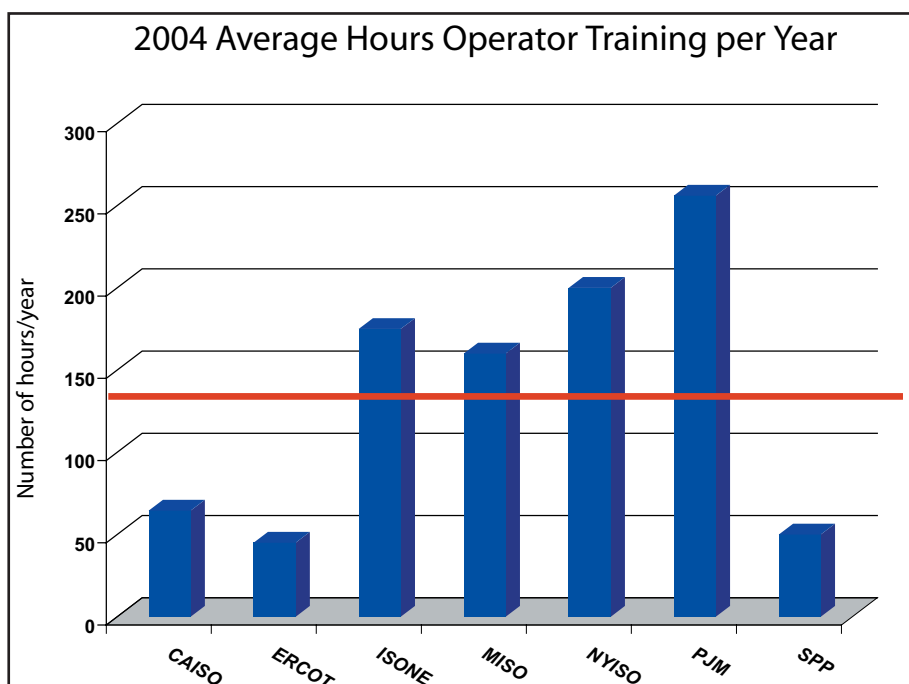

Committee has recommended that grid operators receive between 140 and 200 hours of training (depending on the operator's responsibilities) for operator re-certification (which occurs every three years).⁸

The NERC recertification recommendation for on-going operator training recommends that every operator receive a minimum of 30 hours of simulator training. Many of the ISO/RTOs make extensive use of system simulators for operator training. The United States military, Federal Aviation Administration and other organizations that rely on sophisticated human operator judgments view advanced simulators as the most effective way to build operator experience and understanding, particularly for training in how to deal with emergency conditions and issues effectively. NERC formally commends PJM and NYISO, along with TVA, for their operator training and simulator programs in the "Examples of Excellence" identified in the NERC Readiness Audit programs.

The California ISO, which plans to achieve 200 hours per operator of training in the next two years, started an operator training program that was the first to be certified by NERC. The self-paced program trains new operators for jobs in the control room, requiring trainees to absorb 33 training modules and 130 operating procedures. ERCOT has budgeted \$5.1 million from 2005 to 2007 to build and install an operator training simulator facility. Few control areas have comparable investments in simulator technology and usage.

3 ISO/RTOs improve operating efficiencies

During the hot summer of 2005, ISO/RTOs were able to meet high demands through aggressive system coordination, sharing reserves and extensive communications.

ISO/RTOs provide increased market efficiency through centralized operation of the electric system over a broad region. ISO/RTOs operate across larger regions with more generating facilities than most traditional vertically integrated utilities and can leverage the resources in this expanded area to meet customer demands more efficiently and economically.

Control areas need generation or dispatchable load for operating reserves. These NERC-required reserves handle unexpected system contingencies and are required for following changing energy consumption pattern. ISO/RTOs' enhanced sharing of resources ultimately lowers the costs of maintaining operating reserves. During the hot summer of 2005, ISO/RTOs in the Eastern Interconnection were able to meet high demands through aggressive system coordination, sharing reserves and protecting reliability with extensive communications and evaluation to facilitate the high inter-area power flows.

By managing across a large region, ISO/RTOs can use the most cost-effective units available to serve demand and standby needs, lowering reserve costs. In addition, in several areas ISO/RTOs operate reserve markets, creating additional market efficiencies. For example:

- The New England and New York regions were able to reduce costs to customers through a reserve-sharing agreement that improved reliability and reduced costs. Through the ability to draw upon its neighbor's reserves under specified conditions, New England has saved millions of dollars in energy uplift payments by reducing payments to generators that would otherwise operate out-of-merit to meet reliability reserve requirements.
- As PJM has integrated new areas it has been able to reduce the reserve margin of installed capacity required to assure an adequate cushion of generation above demand within the region. For the Mid-Atlantic region, reserve sharing has allowed the area to shrink the reserve margin by about 2,000 MW, which represents a significant savings in capacity payments for affected loads.
- In 2004, California's ancillary services (operating reserves) prices fell by 12 percent, while fuel-price-adjusted energy costs have fallen to 2000 levels. These cost reductions are due in part to a five-percent

⁸NERC Personnel Certification Governance Committee, "System Operator Certification Program," David Carlson, presentation to the NERC Stakeholders Committee and Board of Trustees, May 5, 2005.

The Value of Independent Regional Grid Operators

increase in low-cost energy imports enabled by added transmission capacity, and an 18 percent increase in the overall supply of electricity to the California ISO from 2003 to 2004.

A study by Global Energy Decisions, LLC, looked particularly at the effect of integrating Commonwealth Edison, American Electric Power and Dayton Power & Light into the PJM regional power market in 2004 and 2005. GED concludes that the production cost savings associated with the reduction of seams between the new utilities and PJM's energy markets equaled about \$70 million for PJM in 2004 (annualized; the integration occurred in October 2004) and \$85 million for the entire Eastern Interconnection. Furthermore, these production cost savings from the expansion will continue year after year, lowering costs for PJM wholesale electricity buyers.⁹

Often, ISO/RTOs can optimize regional operating practices to reduce wholesale buyers' costs, lowering transmission rates and reducing the cost of operating the transmission system:

- ERCOT began using real-time dynamic transmission line ratings in March 2005. The new system sets real-time dynamic line ratings as a function of ambient temperatures (cooler lines can carry more electricity) to ensure that transmission lines are at their optimal level for system reliability, market effectiveness and efficiency. This is estimated to save up to \$33 million per year in congestion costs.
- The NYISO replaced its existing computing platform with a state-of-the-art Real-Time Scheduling system. In the past, the NYISO's Day-Ahead and Real-Time markets operated on two different computer platforms, which created inefficiencies between the day-ahead market and real-time markets. The new system cost \$32 million and is expected to pay for itself in two years.
- In 2004, PJM began using new software that uses advanced mathematical techniques for unit commitment, to optimize power plant scheduling, and to be sure that the most efficient units are available when needed for generation or reserves. The new system has produced estimated savings to customers of \$56 million per year.
- The Midwest ISO and PJM signed a joint operating agreement in 2004 that established procedures to improve coordination of regional congestion management and data exchange, beginning in late 2004. Coordination of the market-to-market power flows began on April 1, 2005. The two RTOs will expand coordinated operations through enhancements to the joint and common market, spanning 239,000 MW of load and 282,240 MW of generation. Coordinated operations and constraint management will ensure that wholesale electric purchasers in both markets receive the lowest cost generation available from resources in both markets on a highly reliable system.
- ISO-NE's forward reserve market has attracted a significant increase in supply offers to provide contingency coverage with fast-start resources, improving reliability and market efficiency while reducing the need for new plants.
- ERCOT created and implemented remedial action plans and special protection schemes to protect reliability. These schemes have reduced congestion costs in the ERCOT market by over \$70 million per year.
- Working through the Southwest Transmission Expansion Planning (STEP) sub-regional planning group, the California ISO and neighboring control areas developed a plan to improve the flow of electricity across the southwest. More than 6,000 MW in new generation has been built in the region in recent years, much of which is now shipping power into California.

Every ISO/RTO performs outage coordination, looking several months ahead at asset owners' forecasts of maintenance and planned outages for all generation and transmission assets (at 69 kV and above) to be sure

⁹Global Energy Decisions, LLC, "Putting Competitive Power Markets to the Test – The Benefits of Competition in America's Electric Grid: Cost Savings and Operating Efficiencies", July 2005, at RS-15.

Every ISO/RTO performs outage coordination to be sure that the combination of outages does not violate local or regional reliability criteria while accommodating the maintenance needs of grid equipment.

that the combination of outages does not violate local or regional reliability criteria while accommodating the maintenance needs of grid equipment. Through this coordination, the ISO/RTO can minimize the effect of simultaneous outages on reliability and develop special solutions for any reliability or congestion problems that might arise.

Outage coordination is a significant task. In New England, for example, an average of 30 assets per day is scheduled to be out of service (excluding unplanned outages), so ISO-NE requires outage schedules to be submitted 12 months in advance and can deny and reschedule outages that might compromise reliability or market efficiency. When market operations began in 1999, ISO-NE did not perform outage coordination, and annual congestion costs reached \$150 million per year. After they began outage coordination in 2000, congestion costs dropped by \$40 million each year, saving customers at least \$160 million in avoided congestion costs, lowering locational marginal prices, and reducing the number and magnitude of price spikes. Further south, PJM was able to significantly reduce congestion costs on the Delmarva Peninsula by rescheduling transmission maintenance at the head of the Peninsula to times when loads on the Peninsula were lower.

Elimination of pancaked rates

By combining a number of transmission systems into a large, unified service area, ISO/RTOs reduce the fees paid by wholesale customers for wheeling energy through the area. Before RTO formation, an energy buyer who wanted to import electricity from a distant generator would have to pay a fee to every transmission owner on the path between the producer and the delivery point on the grid. One of the most valuable benefits of ISO/RTO formation for electricity buyers has been to eliminate these “pancaked rates,” substituting a single rate for the wheel through an ISO/RTO region.

At the same time, the process of requesting and receiving transmission service over a long distance has been made much easier for the buyer. The process once required multiple requests for every transmission provider, with potentially different or incompatible timing and availability. With ISO/RTOs in place, the buyer makes a single request for transmission service anywhere within or across the ISO/RTO region and gets a single response that assures reliable transmission service for the transaction. Additionally, generation within that footprint receives network transmission service across the region – which, as in PJM or the Midwest ISO, reaches millions of retail electric customers in many states.

The impact of eliminating rate pancaking has been substantial. As illustrated in Figure 3, before the formation of the Midwest ISO, it cost \$1,718 for transmission service to deliver 100 MW of coal production for one hour from a plant in Vectren’s Indiana system through the Cinergy, NIPSCO and ITC transmission systems to Detroit. After the Midwest ISO system adopted a single regional tariff, the cost for the same transaction dropped to \$464 per hour, a savings of \$1,254 in transmission costs for the single transaction. These savings add up quickly – for 1,000 MWh wheeled across this path, the purchaser would save \$1.254 million from the Midwest ISO tariff’s elimination of pancaked rates. Given the number of transactions that flow through multiple systems across the Midwest and other regions managed by ISO/RTOs, the savings from rate pancaking are substantial.

Consider also the case of the New York and New England ISOs, which worked with regional transmission owners, state regulators and stakeholders to eliminate “through-and-out” (TOUT) transmission service charges for exports between the two regions, effective December 2004. The TOUT charges on flows between the two regions created a barrier that increased the cost of trading between the two regions, raising the costs of every import to its buyers and burdening many potential trades with TOUT costs that rendered

them uneconomic. With the removal of TOUT charges, exports from the neighboring region should become more cost-competitive with in-region generation, and the level of trading and flows between the two regions will increase, producing lower electricity costs in both regions.

At its start-up, the California ISO applied an ISO-wide transmission access charge. Since then, starting in 2001, the California ISO has been transitioning from individual rates for ten transmission owners, including investor-owned utilities, municipal utilities, a merchant and a federal power administration, and is making a transition over a 10-year period, to apply a single grid-wide rate for the entire ISO. When the transition is completed in 2010, annual transmission cost savings to some load-serving entities will reach as high as \$23.9 million per year.

Figure 3 — Transmission Rate Pancaking Illustration

One of the most valuable benefits of ISO/RTO formation for electricity buyers has been to eliminate "pancaked rates."

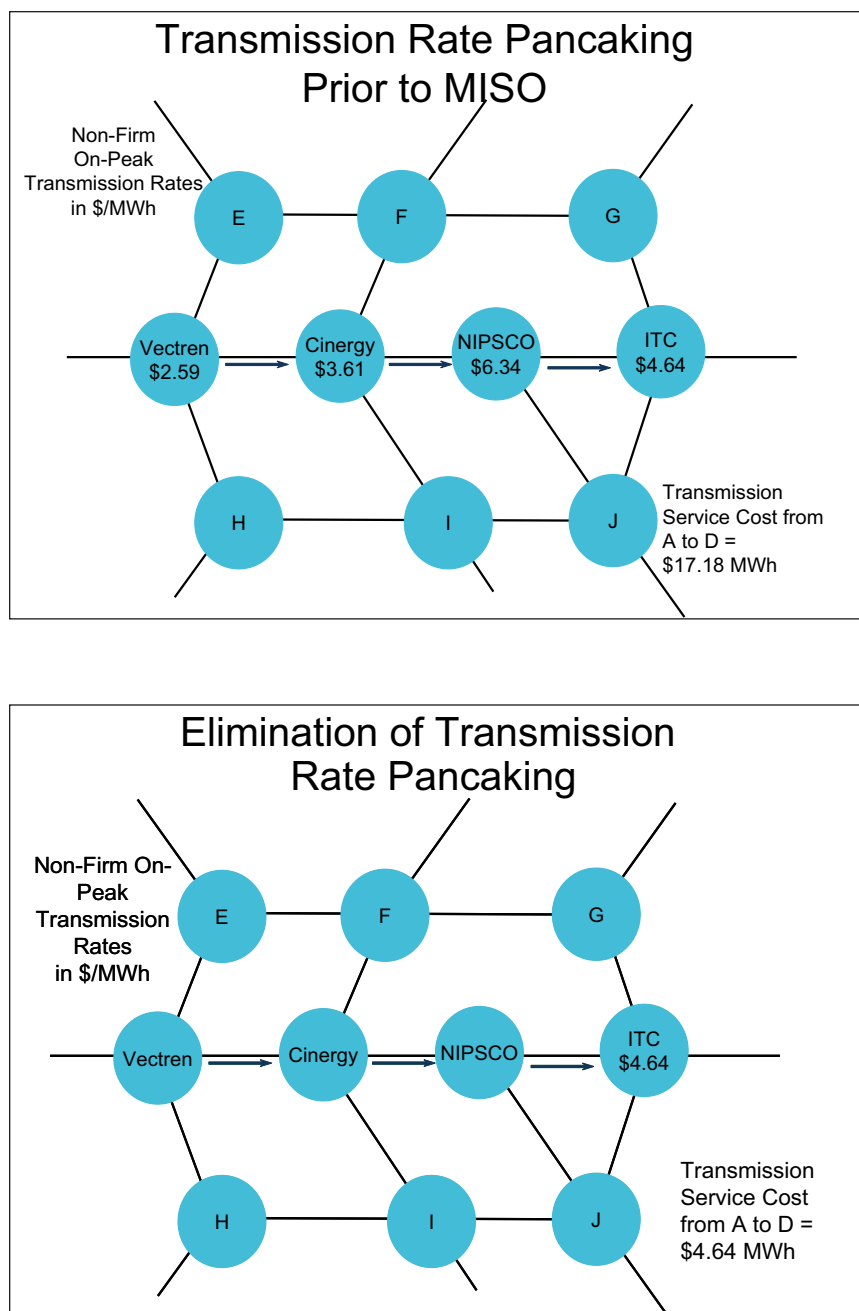

Efficiency improvements from RTO-facilitated competition

Analyses of wholesale competition in numerous regions have concluded that competition between generators has driven wholesale electricity prices down. This occurs because of several factors:

- Construction of new generators (many facilitated and hastened by ISO/RTO generation interconnection queue management) has brought efficient new power plants on line with lower heat rates and lower operations and maintenance costs. These units have gained fair, independent access to transmission services and potential buyers through ISO/RTO administration of transmission scheduling and information posting.
- Competition among generators – particularly through economic dispatch run by ISO/RTOs, and bid-based spot markets administered by ISO/RTOs – has forced older units to become more efficient, with equipment upgrades and improved maintenance that have improved unit heat rates (Btu/KWh) and capacity factors. The result has been more efficient use of fuel and higher output for the region as a whole, reducing the need for new plant construction. Many older units that were too costly and inefficient have been mothballed or retired, leaving a more efficient fleet with a lower net and marginal heat rate.

In New England, ISO-NE found that overall system production costs dropped because the system-wide weighted average heat rate has declined by 5.6 percent since 2000. The percentage of time that generation units are available for dispatch has increased from 81 percent in 2000 to 88 percent in 2004.¹⁰ In New York, competitive pressures have improved power plant availability during critical summer months, with the result that on-peak plant availability improved from 86.5 percent before NYISO operation to 90.3 percent today.

The Global Energy Decisions study concludes that wholesale competition dramatically improved power plant efficiencies. “The skill of experienced fleet operators, the standardization of procedures and maintenance, and the combined buying power for fuel, equipment and supplies have produced dramatic improvements in capacity factors and plant performance,” the study concluded.¹¹ GED found significant cost savings and energy efficiency from reduced refueling outages, improved load factors and reliability across the generation fleet. GED also concluded that industry restructuring and consolidation of the nuclear fleet under experienced operators has produced shorter refueling outages, higher capacity factors, and lower nuclear operations and maintenance expenses for those plants that are competitively owned, with similar results for coal-fired plants.

TXU Energy has looked at the effect of \$15 billion in new generation investments within ERCOT upon that region’s heat rates and costs. TXU concluded that incremental heat rates within ERCOT fell from about 14,000 MMBtu/MWh in 1999 to 8,000 MMBtu/MWh in 2004 – a 40 percent increase in the efficiency of the marginal unit, which was reflected in lower marginal price bids in ERCOT’s long-term contract and spot markets. TXU then estimated the impact of this improvement upon customer prices, normalizing for the sustained increase in natural gas and coal prices since 2000, and concluded that ERCOT’s customers have saved over \$10 billion from these efficiency improvements.¹²

¹⁰ISO New England Annual Markets Report, 2005.

¹¹Global Energy Decisions, LLC, “Putting Competitive Power Markets to the Test – The Benefits of Competition in America’s Electric Grid: Cost Savings and Operating Efficiencies,” July 2005, at RS-8.

¹²Presentation by Paul O’Malley, CEO, TXU Energy, February 8, 2005, “Electric Competition in Texas – A Success Story,” presentation by C. John Wilder, CEO, TXU, “Texas Electric Market Restructuring – A Customer Success Story,” and discussion with Jonathan Siegler, TXU.

While estimates of the cost savings from generation fleet efficiency improvements clearly differ, there can be no dispute that these efficiency improvements have had marked impacts on the air pollution emissions resulting from electricity production over the past few years. With every improvement in fleet-wide power plant efficiency, and with every KWh generated from a more efficient new plant rather than an older, less efficient plant – as occurs with ISO/RTO-coordinated economic dispatch – emissions of sulfur dioxide, mercury, nitrogen oxides, particulates and carbon become marginally lower and North American airsheds become cleaner. ISO-NE estimates that the addition and use of 9,450 MW of new, low-polluting generation capacity in that region has reduced nitrogen oxides emissions by 32 percent, sulfur dioxide emissions by 48 percent, and carbon dioxide emissions by six percent (relative to the existing units).¹³

4 ISO/RTOs operate markets that lower customer energy costs

ISO/RTOs conduct various activities that improve accessibility for market participants, including improving the coordination and compatibility of billing and settlements for trading within and between regions; increasing the consistency of bidding protocols across regions, including creating single-point regional transaction entry; allowing cross-border congestion hedges; and moving toward wide-area locational marginal pricing (LMP) dispatch that can increase the efficiency of inter-ISO/RTO energy trading.

Most electricity transactions in North America occur through bilateral agreements, in which two market participants enter directly into a contract. Most of the electricity traded in bilateral contracts is for the forward sale of electricity for a period ranging from one month to several years, at a price that is locked in under the contract. By examining reported energy trades, FERC estimates that about 28 percent of reported U.S. electricity wholesale sales were delivered under long-term contracts of one year or longer.¹⁴ Forward contracts are critical for risk management, allowing the participants to create price certainty and reduce exposure to future price changes or volatility.

In the regions where ISO/RTOs operate bid-based markets for spot market energy, those may be for real-time (every 5 minutes), hourly in the day-ahead, and ancillary services markets. Where a central organized market exists, short-term electricity transactions in those regions are conducted in the ISO/RTO market rather than through bilateral contracts (such as those in the Pacific Northwest). ISO/RTO spot market prices influence and sometimes index bilateral agreements and inform forward prices.

ISO/RTOs use proprietary market technology to sort and match market participant offers and bids and determine the most efficient transaction price. In day-ahead markets, market participants lock in the cost of their energy with a higher degree of price certainty than is available in the more volatile real-time market. Day-ahead markets contribute to system reliability by providing a financial incentive to ensure that sufficient generating resources will be available in advance to meet real-time energy demand.

Energy needs not covered by long-term or day-ahead market transactions will be served in the balancing or real-time market. Real-time markets typically have higher levels of price volatility (fluctuations) than other markets due to unforeseen conditions, including changes in the weather, generator and transmission outages, or other factors that may affect supply or demand. The amount of energy traded in real-time markets varies across ISO/RTOs but typically is about five percent of total load.

¹³ISO-NE Annual Markets Report, 2005.

¹⁴FERC 2003 State of the Market Report at 20.

The Global Energy Decisions study concluded that wholesale electric "customers realized \$15.1 billion in value from wholesale electric competition in the 1999-2003 study period" across the eastern inter-connection.

Savings from organized markets

Wholesale electric competition in the ISO/RTO-organized markets has created significant savings for electricity buyers. ISO-NE reports that with market operations beginning in 2000, adjusted wholesale prices of electricity in New England declined by 11 percent from 2001-2004 (after adjusting for the increase in fuel prices). This reduction saved approximately \$400 million per year for the wholesale market. In that same period, New England saved an additional \$300 million each year by reducing generation uplift costs, decreasing requirements for regulation service, and improving generation availability rates by three percent. Similarly, PJM reports that after its region expanded to integrate American Electric Power in Spring 2004, fuel-adjusted energy prices declined by 4.2 percent.

A Midwest ISO study of the cost savings expected from the operation of real-time and day-ahead energy markets beginning in April 2005 concluded that the implementation of organized markets in place of non-organized markets would drive down spot energy prices, producing potential annual savings of \$713 million to Midwest electricity customers.¹⁵ When the Midwest ISO began energy market operations in April 2005, it estimated that total savings from the introduction of centralized security constrained economic dispatch using LMP would yield annual gross production cost savings of approximately \$255 million across the Midwest.¹⁶

A study of the Midwest ISO-PJM-SPP common market proposal by Energy Security Analysis, Inc. concluded that lower energy prices resulting from the combined market would produce savings of \$7 billion for electricity customers over 10 years. Author Edward Krapels found that one of the most important market benefits comes from the interaction between forward and spot markets. Specifically he notes that in inefficient and illiquid markets, the forward price is much higher than the spot market price but with increased liquidity the size of that spread declines. Loads pay for the premium price of forward markets because they are unwilling to take the volatility risks of buying primarily in the spot market. As liquidity increases and drives down the spread between forward and spot prices, Krapels concludes that every \$1/MWh reduction in the forward market premium in the Midwest would deliver savings to customers of \$1.7 billion per year.¹⁷

A 2005 cost-benefit study for the SPP's Regional State Committee on the impact of an SPP market for energy imbalance service within SPP indicated that the entire Eastern Interconnection would realize \$1.2 billion in production cost savings over ten years, over half of which will directly flow to SPP customers.¹⁸

The Global Energy Decisions study concluded that wholesale electric "customers realized \$15.1 billion in value from wholesale electric competition in the 1999-2003 study period" across the Eastern Interconnection, compared to a simulation of grid operation without wholesale competition.¹⁹ These savings came from increased construction and operation of highly efficient power plants by independent producers, selling at lower prices than would have been charged under cost-of-service rates without wholesale competition.

¹⁵FERC Docket Nos. ER04-691-00 and ER04-104-000, Dr. R.R. McNamara at 50, June 25, 2004.

¹⁶Id. At 51."

¹⁷Presentation by Edward Krapels, "Analysis of Effects of Single Midwest ISO-PJM-SPP Market", July 11, 2002, ESAI.

¹⁸Charles River Associates, "Cost-Benefit Analysis Performed for the SPP Regional State Committee, Final Report," July 27, 2005.

¹⁹CERA, "Beyond the Crossroads -- The Future Direction of Power Industry Restructuring," October 2005. pp ES-1., I-4, I-12.

The Value of Independent Regional Grid Operators

The CERA report *Beyond the Crossroads* finds that, “U.S. residential electric customers paid about \$34 billion less for the electricity they consumed over the past seven years than they would have paid if traditional regulation had continued.” The study finds that, contrary to popular belief, “deregulation of the U.S. power business has lowered power prices for the majority of electricity customers” – on average, 16 percent lower - compared to prior periods and to what prices would have been under traditional regulation. CERA finds that the Northeast, which has been restructured for the longest period, enjoyed the greatest electricity price reductions from competition, with savings equal to \$7.30/MWh since 1997.

The Midwest ISO reports that while its market operation costs are estimated at about \$11.3 million per month, the new Midwest wholesale market have produced between \$59 and \$154 million in production cost savings (depending on modeling assumptions), with a benefit/cost ratio between 5:1 and 14:1.

Price transparency has value

Within organized markets, every market participant can see pricing information and thereby avoid using the least efficient plants. ISO/RTOs use security-constrained unit commitment software to dispatch the units with the lowest bids consistent with transmission availability and grid reliability requirements. The result creates prices that every market participant can see and benefit from, and avoids using the least efficient plants unless they are needed for dispatch adequacy or reliability. In contrast, dispatch outside organized markets may not always use the most efficient generators, but the lack of market prices and transparency about which plants are operating and at what cost, means that customers and regulators cannot see the excess costs.

FERC observes that:

Locational marginal, day-ahead and real time process, along with capacity and ancillary services within ISO/RTO markets, are almost entirely transparent and make much information available in real time. Such transparency rests on standardized operations and large, centralized mechanisms to collect and disseminate the information. By contrast, most ... bilateral electric markets provide far less detailed information. Some electric power markets are almost entirely opaque to both regulators and to price-takers. In these markets (such as electricity in much of the southeast), so little information is available that price indices either do not develop or have little value in price discovery.²⁰

FERC also notes that:

Customers in regions without organized markets had significantly less market information about prices, price formation, system conditions and transmission infrastructure needs than their counterparts in regions with organized markets. Outside organized markets there was limited market price information regarding the value of electricity over time and across locations of the regional needs for transmission and generation siting, resulting in:

- ◆ Opaque (non-transparent) prices;
- ◆ Less-efficient dispatch of power plants;
- ◆ Use of less-efficient congestion management tools; and
- ◆ Muted or distorted signals for investment, particularly where it is most needed.

The poor quality of information outside organized markets limited the effective functioning of wholesale electric markets in those areas, potentially resulting in higher costs to customers.²¹

²⁰FERC 2004 State of the Market Report at 36.

²¹FERC 2003 State of the Market Report at 8-9.

ISO/RTOs enhance reliability by informing all market participants on the state of grid conditions and market operations through the public posting of electricity prices and other key system information on their websites. Market prices in ISO/RTO markets reflect real-time system conditions. Higher prices signal to loads that generation supply has tightened, enabling loads and off-line generators to respond in a timely manner. In the markets where LMP is used, high LMPs give very specific signals as to where more generation or power delivery is needed and valued, while lower LMPs indicate the reverse.

LMPs produce results. Since 1999, 3,710 MW of new generation has come on-line within the NYISO control area. Most was built in New York City, on Long Island and in other areas where load growth and wholesale energy prices are the highest in the state. These investments clearly followed the price signals sent by New York's locational and energy capacity markets about where power would be needed and valued most.

Spot market prices and trading hub price indexes serve as a benchmark for prices in many long-term contracts, and can be used by energy regulators to evaluate regulated load-serving entities' electricity portfolios. Where market prices and other transaction information are liquid and transparent, that information allows buyers and investors to evaluate potential generation, transmission and demand response opportunities, and encourages new merchant activities.

Market liquidity

Market liquidity exists when a buyer or seller can easily and quickly transact at a prevailing price in the marketplace because there are enough other buyers and sellers to take the trade at a market-established price. High liquidity requires a high volume of units traded. Prices in markets with higher liquidity tend to be less volatile. FERC and others studying regional electric markets have found that "electricity price volatility generally declined in regions with organized markets, but generally increased in regions without organized markets."²² Liquidity is affected by the number of participants and the availability of information, capital and credit within a market.

Where liquid electricity physical markets exist due to the open, centralized and standardized approach to grid operations, liquid financial electricity markets have arisen. These financial markets trade in commercial paper and derivatives based on the electricity commodities traded at liquid hubs. For example, the New York Mercantile Exchange has established liquid financial electricity-based markets for NYISO Zones A, G and J; the New England Hub and the PJM Western Hub; and recently added eight peak- and off-peak Midwest trading hubs.

Table 4 illustrates liquidity differences, showing the volumes of electricity traded on the Intercontinental Exchange (ICE) in 2004. FERC reports that traded volumes tend to be higher in the long-established markets and hubs (PJM, Cinergy and Mid-Columbia in particular). The high trading volumes at the Pacific Northwest and Palo Verde hubs reflect their proximity to the California market and the California ISO's organized market – California has the largest loads in the West and insufficient in-state generation, so many of the trades occurring in the Pacific Northwest and Southwest eventually sink in California and will be influenced by California ISO spot market prices.

²²FERC 2003 State of the Market Report at 7.

Table 4		
Daily Average and Maximum Trade Volumes on the Intercontinental Exchange For 2004, by Region and Hub		
	TRADE VOLUMES (MWh traded / day)	
REGION AND HUB	Average	Maximum
ISO / RTO Organized Market		
CAISO	16,852	50,400
ERCOT	6,193	31,200
ISO-NE	5,163	24,000
Midwest ISO Cinergy	53,647	133,600
NYISO	3,455	18,400
PJM		
PJM-West	28,314	84,000
Northern Illinois	7,450	31,200
Non-Organized markets		
Northwest		
Mid-C	23,626	72,000
COB	8,156	30,400
Southeast	none	none
Southwest		
Palo Verde	20,953	49,600
Four Corners	3,800	14,400
Mead	7,116	22,400
Source: FERC 2004 State of the Market Report, Regional Market Profiles		

If a market has low liquidity, the losses to buyers and sellers will be higher. In a high liquidity market, prices are more predictable because there is a higher probability that the next trade will close at the same price as the last price; in a low liquidity market, prices are more volatile and therefore the costs and revenues from trade are riskier and less predictable. Low liquidity also means that when a buyer or seller needs to place a trade quickly to balance a position or expected demand, there may be no counterparty available to transact with, so the buyer or seller may end up with higher costs absent the ability to trade.

Risk management

Congestion occurs on the transmission system when there are limits on the capability of the system to deliver scheduled transactions that would be economically desirable or optimal, so the buyer's demand must be served from more costly sources (for instance, from redispatch of local power plants). Congestion costs are the costs of that redispatch relative to the lower cost transactions foreclosed by the physical delivery limitation. Although grid flows are managed to assure that every customer receives sufficient electricity, ISO/RTOs track and account for the transactions that are blocked due to grid congestion, and tabulate the increased costs of the transactions that occur in their stead.

ISO/RTO regions that run competitive wholesale markets using locational marginal pricing or zonal pricing use those pricing signals to manage congestion. Load-serving entities can manage congestion costs using financial hedging instruments (usually called financial transmission rights or FTRs), which are generally distributed to historical users of the grid (primarily those serving loads) and sometimes through auction. Once issued, FTRs can be traded in annual and monthly auctions administered by the ISO/RTO, or traded bilaterally with other market participants.

In contrast to ISO/RTOs, where congestion is explicitly recognized and quantified, areas run by an integrated transmission and generation company internalize congestion and redispatch costs and allocate them across all customers. This means that the congestion points and highest cost areas on the company’s grid are not obvious to outside observers, and it is more difficult to identify where new investment in generation, transmission and demand management are needed to improve grid reliability and economics.

Organized markets offer the most options for risk management and risk reduction. These include a mix of long-term, day-ahead and real-time markets to structure an electricity portfolio with predictable electricity prices. Since most organized markets also have one or more liquid trading hubs, entities like the New York Merchantile Exchange can establish financial markets based on electricity commodity prices at the trading hubs, creating another way for market participants to manage financial risks.

Virtual bidding is a particular risk management option offered in the New York ISO since 2001. Under virtual bidding, market participants with qualifying credit levels can buy and sell energy in the day-ahead market and sell it in the real-time market, or cover a day-ahead sale with a real-time energy purchase, with “virtual” but not actual physical energy holdings. The difference between the prices in the day-ahead and real-time markets will determine the gain or loss realized by the virtual bidder. Virtual bidding is an arbitrage mechanism that helps to converge prices in the two markets. Its use has caused market price differentials in New York to decrease by 11 percent over the past four years, yielding price savings for New York electricity customers.

Market monitoring

One thing that distinguishes ISO/RTOs from traditional systems is that each ISO/RTO has a market monitoring function or is associated with an independent market monitor that, like the ISO/RTO, is unaffiliated with any market participant. Market monitors observe and analyze the behavior of market participants to protect against the exercise of market power (the ability of a market participant to unilaterally influence market prices through supply withholding or other means).

Market monitors help ensure that market prices remain fair and competitive. In most organized markets, FERC has approved a set of market mitigation procedures that re-set prices from market levels when conditions indicate that market power could have affected price levels; the market monitor oversees market mitigation operations. The market monitor also scrutinizes the region’s markets and circumstances and offers recommendations to the ISO/RTO and FERC about how to improve conditions and assure sound market operations to complement and improve grid reliability.

The ISO/RTO market monitors’ data collection and analyses generally offer the best source of information about what is occurring in the nation’s organized markets. Most monitors post annual and monthly analyses and statistical compendia on their RTOs, and report quarterly to FERC on activities and characteristics of the markets they oversee.

Challenges ahead

Wholesale electric markets are generally sound, but there remain several significant challenges to be resolved. These include:

- Current FTRs have a one-year term. But many market participants seek longer-term transmission rights to gain greater assurance that long-term contracts and native load requirements will be deliverable into the future. They argue that these longer-term rights will reduce risk and increase certainty for

Market monitors help ensure that market prices remain fair and competitive.

both sides of the deal. However, where long-term FTRs make the holders indifferent to the costs of congestion, or cannot be matched to the actual realities of grid transmission flows, such FTRs could compromise market effectiveness.

- Better mechanisms are needed to provide sufficient certainty and incentives to get new generation and transmission built in a timely fashion.
- Although it is economically appropriate to charge electricity users the true value of the energy they consume, there are legitimate equity issues with respect to congestion and locational marginal pricing. Firm cost allocation principles may break down when not all benefits are spread equally. Similarly, FTRs are a hedge against congestion pricing and high LMPs, but when some parties face high prices and others do not – or when market buyers choose to ignore or misuse the hedging tools made available – the high cost consequences will have political implications for all market participants.
- Until demand response is fully realized and integrated as a market resource, and every region has a high proportion of customers who can see price and reliability signals and change their electricity consumption quickly in response, the benefits of wholesale electric markets will not be fully realized. In addition, considerable work will be required to develop effective demand response programs, secure transmission owner and load-serving entity and state regulatory support for those programs, build customer understanding and participation, install effective communications and software infrastructure before demand response can fully participate in wholesale markets and eliminate the need for ex post market mitigation.

5 ISO/RTOs provide fair, independent and open markets, and transmission access

By allowing equal access to the grid, ISO/RTOs facilitate greater competition between power suppliers, allowing all parties to spread their risks and lower their costs.

ISO/RTOs were created as independent, unaffiliated grid operators to provide unbiased, open access to all grid users. By allowing all buyers and sellers equal access to the grid at equal prices and terms, ISO/RTOs facilitate greater competition between power suppliers, allowing all parties to spread their risks and lower their costs. The independent grid operators ensure that competitors do not gain unfair market advantages and enable independent generators to interconnect their facilities to the transmission grid without fear of discrimination from an incumbent utility.

One of the most important roles ISO/RTOs play is to facilitate entry for new generators into the power market by managing grid interconnection and transmission access. FERC has an extensive roster of cases in which independent power producers (IPPs) complain that where incumbent vertically integrated utilities manage grid interconnection processes, the utility discriminated against the IPP by delaying interconnection evaluation or improperly overstating the cost of the interconnection construction needed. Once the independent plant is built, there are numerous cases filed concerning an IPP's complaint that the incumbent utility favored its own generation by denying grid access and transmission services to the independent generation competitor. Documented discriminatory practices have included withholding or miscalculating available transfer capability postings and capacity benefit margins, using discriminatory dispatch to block an IPP's scheduled transactions, and interpreting contract provisions to impede the IPP's transactions while favoring the incumbent's affiliated generation.²³

ISO/RTO management of generation interconnection enables entry of new generators into the wholesale market. The ISO/RTOs perform objective, unbiased management of the generation interconnection queue, interconnection engineering studies, and transmission access calculations. Lacking affiliation to any market participants, the ISO/RTO interprets the rules consistently and fairly for every competitor.

²³FERC 2003 State of the Market Report at 28.

Renewable technologies, particularly wind generators, have benefited from ISO/RTO-managed open access.

Renewable technologies, particularly wind generators, have benefited from ISO/RTO-managed open access. Clear market and technology rules for wind-powered generators help the wind companies better assess the viability of their potential investment. ISO/RTOs are also supporting renewables by improving their ability to compete in markets, as well as their interconnection. After discovering that specific terms and conditions in their market rules were unintentionally harming wind generators by lowering their revenues, the California ISO worked with members of the wind industry to develop revised rules for wind integration into the spot market. Today the California ISO's terms for wind settlements have improved the economics for wind generators in the state. ERCOT has worked with wind generators to develop improved models to forecast wind farm behavior and impacts on the grid, causing modifications to wind interconnection analyses. And ERCOT's 2005 analysis of wind transmission and interconnection issues informed the Texas Legislature when it approved a new law to double the state's Renewable Portfolio requirements.

In regions where there are state-established Renewable Energy Credit trading programs to monetize the value of renewable energy, the ISO/RTOs – including ERCOT, ISO-NE and PJM – are administering renewable energy credit trading programs, providing low-cost, high-value services that benefit renewable resources and improve electricity retailers' ability to offer "green" electricity products cost-effectively. In 2002, New England implemented a Generation Information System that supports compliance for several states' renewable portfolio standards and air pollution compliance requirements, using tradable attribute "tags" for each MW generated.

Demand response growing in ISO/RTOs

Demand response — the ability of customers to see the cost and value of electricity over time and place, and to moderate their usage in response to that cost or value – is critical to the long-term health and effectiveness of wholesale power markets. By giving the customer the ability to say "no" to high prices and choose to consume less electricity, demand response can help moderate supplier market power, improve reliability by substituting for inefficient or inadequate supply-side reserves, moderate electricity price volatility, and improve reliability. A FERC benefit-cost study on RTOs estimated that increasing the demand response programs in use in RTOs would reduce electricity costs by over five percent, for savings totaling \$60 billion in net present value terms.²⁴

ISO/RTOs are working to foster the growth of demand response, with the ultimate goal of building competition and balance between generation, transmission and demand solutions. The bulk of the nation's demand response program growth is occurring within ISO/RTO service areas, facilitated by the availability of real-time LMPs that reveal the value of electricity across time and place:

- ISO-NE and NYISO have developed economic bidding and reliability protection programs to give customers the opportunity to bid their load reductions into the wholesale electric market, with systematic evaluation of demand response impacts. New York offers three demand response options to purchase load curtailments from large industrial and commercial customers. More than 2,300 customers participate and have received over \$75 million in capacity revenues for their load reductions.
- In ERCOT, industrial customers representing more than 2.5 percent of total load are registered to provide responsive reserve service in the market-based Load Acting as a Resource demand response program.

²⁴ICF Consulting. "Economic Assessment of RTO Policy," 2002.

- In New England, load participating in emergency demand response programs has reached up to five percent of ISO-NE system peak demand.
- PJM has participated in the Mid-Atlantic Distributed Resources Initiative, which brought four states and the District of Columbia together to develop common rules and programs for both demand response and distributed generation interconnection and integration.
- California has about 500 MW of load enrolled in its Save-A-Watt Voluntary Load Reduction Program, which gives participants advance notification when energy reserves drop to five percent or less, so participants can lower their loads to help avoid blackouts. Between demand response and voluntary responses to statewide appeals, the California ISO estimates that Californians lowered grid demand by more than 800 MWs during peak hours in summer 2005.

New York, New England and PJM are working to harmonize their demand response programs so customers will see similar programs and terms in all three regions. Ultimately, they may be able to fully compete against transmission and generation alternatives across the entire Northeastern U.S. New England's ancillary services market project is integrating demand response into real-time operations to better balance load and generation, and using more cost-effective communications and telemetry solutions to allow small demand response and distributed generation to satisfy reserve requirements. And if California's plans to install smart meters through most of its customer base succeed, the California ISO will host an unprecedented concentration of customers and load able to see time-specific electricity prices and moderate usage through the use of smart meters.

ISO/RTOs are uniquely able to foster demand response programs and businesses because as large regional service providers, ISO/RTOs provide a platform for regional management of demand response. When the ISO/RTO develops a common approach for demand response integration into the wholesale electricity market – particularly where the ISO/RTO can secure the agreement of several state regulatory agencies to a common set of programs and market terms and conditions – it gives the demand response provider the chance to capture economies of scale through access to a large group of customers spanning many transmission owners and retail service providers, and potentially several states and regulatory schemes. This allows the demand response provider to build a larger group of customers (demand response responders) and to keep them in a stable program for several years with a stable market offering. These factors improve the demand response provider's business model and likelihood of success. With state and federal regulatory support, these programs will hasten the day when customer demand response acts as a healthy counter-balance to supply in wholesale electric markets.

6 ISO/RTOs provide effective regional planning

ISO/RTOs conduct long-term regional planning to identify system upgrade and expansion needs for reliability and increasingly, for economic benefit. Unlike stand-alone utilities which look at reliability needs only within their borders, ISO/RTOs look at the needs across all of the utilities and loads within their much broader boundaries, and explore opportunities for inter-regional benefit. In many regions, their work is complemented by the efforts of Regional State Committees that advise and contribute to the grid operator's planning activities and use the ISO/RTO's resources to conduct additional planning activities.

In a June 2004 study, Eric Hirst reviewed 20 transmission plans, including those from ISOs, regional reliability councils, utilities and transmission companies.²⁵ Hirst concluded that the best planning

²⁵Hirst, Eric, "U.S. Transmission Capacity: Present Status and Future Prospects," June 2004, prepared for Edison Electric Institute and US Department of Energy, Office of Electric Transmission and Distribution

documents were prepared by ISOs, transmission-only companies, and the Seams Steering Group of the Western Electricity Coordinating Council, which he views as having ISO-like characteristics.²⁶ He found that “few of the studies took a broad view of transmission needs and studied both reliability and economics, as well as interconnection and equipment replacement issues.”²⁷ Furthermore, few of the studies looked at transmission project costs or transmission losses, or attempted to analyze the economic benefits or wealth transfers that would result from the projects.²⁸ Hirsch found no detailed transmission plans for the southeast (which has no RTO) or Florida.

Another study for the Edison Electric Institute finds that, “regional transmission expansion planning by ISOs and RTOs has put into play a process that compels the building-out of their transmission systems to maintain reliability across larger and larger market footprints.”²⁹ That study concludes that the most active regional transmission planning exists in the New England and PJM regions, which “lay out comprehensive arrays of transmission projects in pursuit of various well-defined objectives.”³⁰

ISO/RTOs coordinate their planning activities with neighboring areas. Because each ISO/RTO serves a wide region and includes a broad set of stakeholders from the region in the planning process, it can explore a breadth of alternatives to address the reliability problems or economic opportunities identified. This improves the effectiveness of regional system planning and assures that the chosen outcomes will be cost-effective as well as widely accepted and understood. By identifying system expansion opportunities in advance of the need, the planning process gives market participants time to assess the alternatives and propose either a market-based solution (e.g., a merchant transmission line, power plant or demand response) or regulated solution (e.g., a rate-based transmission line).

As the planning organization and stakeholder relationships grow stronger, the plans grow in scope and complexity, starting with work to improve intra-regional flows, then moving to inter-regional reliability and economic or environmental improvement projects. Often the next step is to strengthen the plan to address a particular system need or policy issue that exceeds reliability alone. A classic example is the goal-driven work done by the Midwest ISO’s collaboration in the “Wind on the Wires” effort to determine what additional infrastructure will be needed to build market access for potential new wind production in the upper Midwest. ERCOT conducted a similar effort with its stakeholders to determine the most cost-effective ways to deliver existing and proposed wind power production in West Texas to population centers to the east.

After the ISO/RTO’s planners and transmission owners become comfortable with regionally integrated reliability planning, the next step is to look at intra-regional and inter-regional economic opportunities, where new transmission investment can significantly increase inter-regional flows and reduce costs. These opportunities may open the door for merchant as well as classic regulated transmission.

Economic transmission projects

Over the past 20 years, transmission construction took a back seat to generation. Incumbent transmission owners have been reluctant to build wires when their shareholders or retail customers may not directly benefit from such construction. However, an ISO/RTO views system needs from a broader perspective than

²⁶Op cit at 51.

²⁷Ibid, at 43.

²⁸Ibid.

²⁹Energy Security Analysis, Inc., “Meeting U.S. Transmission Needs” July 2005, Edison Electric Institute, at vii.

³⁰Ibid at 5.

An ISO/RTO views system needs from a broader perspective than an individual utility, considering the requirements of the larger grid.

an individual utility, considering the requirements of the larger grid. Because ISO/RTO prices quantify the value of congestion, stakeholders evaluate the economic benefits of building new transmission facilities. This benefit is illustrated in the following examples.

- The California ISO uses a formal economic methodology to evaluate the benefits – including lower transmission congestion costs – of transmission expansion. The ISO/RTO-produced economic justification helped convince regulators to approve a new transmission line serving California’s infamous Path 15 bottleneck. The new high-voltage line added in December 2004 has already reduced congestion by about 40 percent on the north-south backbone of California’s transmission system.
- In the SPP service territory, the congested La Cygne-Stillwell transmission line could not be upgraded by the incumbent utility because that utility could not justify the costs of a stand-alone project. With SPP facilitation, the area’s transmission owners developed an innovative agreement for sharing the costs of the line. The owner completed line expansion work in only four months, and region-wide congestion dropped significantly. Cost recovery for this project was achieved in less than two years.
- In 2005, ERCOT and member transmission owner Centerpoint designed a suite of transmission line upgrades to relieve congestion, increase reliability, and provide operational flexibility for maintenance outages in the Houston area. ERCOT estimates annual production cost savings resulting from the completion of the project at \$63 million per year.

Regional planning and the new transmission investment that result from those plans help to bring some stability to regional congestion levels. Within PJM, for example, although load and transaction volumes have grown markedly over the past five years, continuing upgrades and investments across the PJM system have held PJM’s congestion costs between seven and nine percent of total electricity costs over the past five years, with only one percent of that congestion unhedged.

The information provided through locational marginal prices and extensive transactions enables merchant transmission companies to evaluate building market-based transmission. To date, two merchant lines have been built, and another eight have been proposed or are now under development within or between ISO/RTOs. Merchant transmission, which is built without any risk imposed on ratepayers, appears to be feasible only where organized electricity markets provide sustainable price signals and visibility about the revenues as well as the costs of the project. Such price signals for new transmission do not exist absent locational marginal pricing for electricity.

Regional system planning works

A significant amount of new transmission has been built as a result of regional planning by ISO/RTOs.

- Since ERCOT first began regional planning in 1999, aided by a regulator-approved cost allocation plan, transmission owners in Texas have invested almost \$2 billion in new wires and other transmission system equipment such as transformers and capacitor banks. Another \$2.8 billion in new transmission investment is currently in development.
- Under PJM’s Regional Transmission Expansion Process, utilities in the PJM states have invested more than \$550 million in new transmission lines and equipment since 1999, improving grid reliability and relieving congestion to benefit over 25 million people. Investments for reliability upgrades have eliminated about \$220 million in congestion, with another \$20 million reduction from economic upgrades. Another \$450 million in transmission investments have been identified through the PJM RTEP, and are in various stages of development at this time.
- ISO New England’s planning process has identified the need for over 270 transmission projects totaling nearly \$4 billion. Of these, five major bulk transmission projects have received state siting approval

to date, and a sixth is in process. When the Southwest Connecticut transmission improvements are completed, they will improve reliability and reduce congestion and out-of-market reliability contract costs that today cost Connecticut customers about \$300 million annually. ISO-NE's allocation of transmission costs moderates the cost impacts of local transmission siting configurations, which eases local transmission siting approvals.

- The Midwest ISO's 2005 transmission expansion plan identifies 615 planned or proposed transmission facility additions and enhancements. These represent a total investment of \$2.9 billion through 2009. The plan also lays out various longer-term options that offer wide regional benefit. And thanks to the coordination agreements with PJM, the two RTOs are discussing possible new bulk inter-regional transmission lines to enhance reliability and trade between the two regions.
- The California ISO's grid planning process develops five- and ten-year transmission plans. If the utilities do not step forward to build planned projects, the ISO will solicit third parties to pursue the expansions. Since it began its grid planning role, the California ISO has approved \$3.32 billion in transmission upgrades.

Recent experience across the nation has shown that projects incorporated and analyzed within ISO/RTO regional plans have a high probability of regulatory approval and completion. In New England, Texas, and other RTO regions, transmission projects that were studied and endorsed by an experienced ISO/RTO planning group and process entered the regulatory process with high credibility and stakeholder support, with a clear reliability and/or economic justification provided by the ISO/RTO.

Looking ahead, the Edison Electric Institute's 2005 Electric Transmission Capital Budget and Forecast Survey of investor-owned utility (IOU) transmission owners found that those IOUs within ISO/RTOs will contribute approximately 70 percent (more than \$16 billion in 2003 dollars) of planned investment to the grid between 2004 and 2008.³¹ NERC data indicate that over 2,175 circuit-miles of new transmission (230 kV and above) are planned for construction within ISO/RTOs between 2005 and 2009.

In contrast, "utilities in regions without RTO markets don't get the price signals to invest in load pockets."³² Additionally, the lack of a formal planning process can impede area infrastructure development. FERC has concluded that, "attempts to enhance the links among Southern California, the Pacific Northwest, and the Southwest are impeded by the absence of a formal regional planning organization."³³

Cost certainty enhances grid investment

When transmission owners have certainty about the manner, likelihood and timing of investment recovery, they are more likely to commit to significant new transmission investments. Experience in ERCOT and SPP illustrates this.

In ERCOT, the transmission regulator established a policy that transmission costs should be shared equally by all ERCOT loads and ratepayers, because all would benefit from the reliability and economic benefits of transmission improvements. Consistent with this policy, all new transmission investments are allocated and collected by load-ratio share to all ERCOT transmission customers, and then repaid to the transmission investor. This long-established cost allocation rule, along with aggressive regional planning, facilitated significant new investment – almost \$5 billion invested, planned, or under construction to date – fully half of the investment tabulated by EEI from investor-owned utilities for the past five years.

³¹E-mail from Edison Electric Institute staff, July 2005.

³²FERC 2004 State of the Market Report, at 61.

³³Op cit at 27.

SPP has two programs to promote transmission expansion. One program allows customers to pre-pay for short-term transmission service, with the funds used for system upgrades that will directly improve short-term transmission service availability. SPP has also proposed a transmission cost allocation program to fund upgrades needed to improve grid reliability and economics-driven upgrades. The allocation offers a pre-established sharing for new transmission between the entire SPP region and the specific zones that benefit from the new transmission.

Generation interconnection

Closely related to the long-term regional planning process, ISO/RTOs manage the analytical and administrative processes of generation interconnection. This entails receiving interconnection requests, conducting impartial, expeditious technical analyses of the impact of each generator individually – and groups of generators, collectively – interconnecting to the grid, and determining and allocating the costs of new transmission construction to connect the new generator to the bulk power system. Effective queue management requires a significant commitment of technical staff in every ISO/RTO, and has freed up technical staff and resources within the utilities that once performed such work (sometimes with less prompt and impartial results).

In one example of effective interconnection queue management, SPP has streamlined its interconnection request process by aggregating interconnection and transmission service request studies. This allows them to expedite the study process and better identify the cumulative impact of new interconnections upon the regional grid.

7 RTO costs flatten with size and experience

ISO/RTO costs to customers vary with the size of the load served and the number of services and level of functionality that each ISO/RTO offers. While the total cost growth of ISO/RTOs has slowed markedly, the cost per customer has flattened or fallen across the board as ISO/RTO services and organizations have matured. ISO/RTO costs are low compared to the benefits discussed above.

Figure 4 shows ISO/RTO revenue requirements per MWh served, averaged across the seven U.S. ISOs and RTOs over time. The industry average cost per MWh of load served grew as the ISO/RTOs were increasing

Figure 4 —
ISO/RTO Costs Per Megawatt Hour of Load Served
(in dollars per megawatt hour)

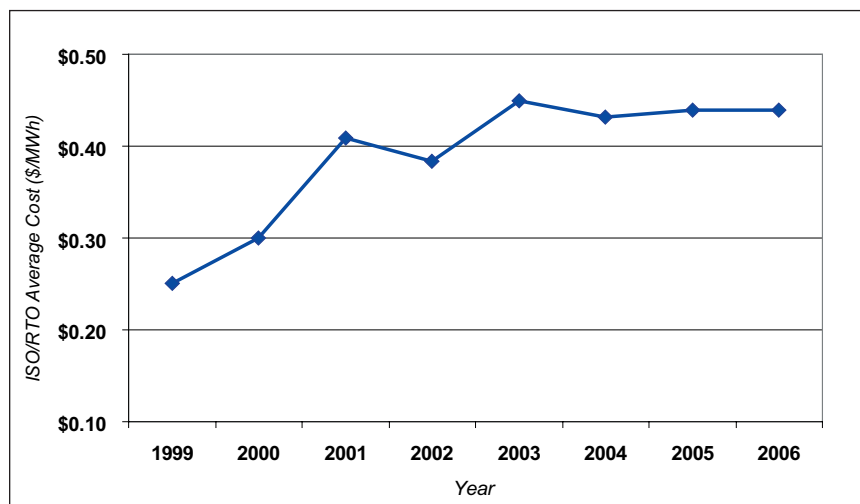

The costs of ISO/RTOs are quite small relative to the end-use customers' delivered electric bills.

their service offerings from 1999 through 2002, but has been relatively constant from 2003 through 2006 (as projected).

The total cost across all ISO/RTOs has increased from approximately \$280 million in 1999 to a projected \$1.1 billion in 2006. While costs increased, load served by ISO/RTOs has grown from 1.1 billion MWh in 1999 to a projected 2.5 billion in 2006. Thus, industry average costs per MWh have been flat since 2003. Information on each individual ISO/RTO's costs over time is provided in Appendix A.

The increase in average cost per MWh from 1999 to 2003 is explained primarily by the increase in the number of services provided by the ISO/RTOs during this period of time. ISO/RTOs began operating real-time markets with market-based solutions for transmission congestion management in the late 1990s. Today nearly all ISO/RTOs operate spot markets, with SPP scheduled to begin market operations in 2006.

The costs of ISO/RTOs are quite small relative to the end-use customers' delivered electric bills. For example, the typical residential customer in New England pays about \$0.60 per month for the market operations, grid management and planning services of ISO-NE. In the Midwest the average customer pays only \$0.35 per month for the Midwest ISO's services, while the average customer in the PJM region pays \$0.33 per month for the full suite of RTO services. ISO/RTO costs are similar in other regions. ERCOT's average fees equal about \$5 per year; the NYISO residential customers' fees average \$4.56 per year; and California households pay an average of \$5.16 per year for the ISO's services.

As Table 5 shows, ISO/RTO service offerings are growing over time as relationships between members and their respective ISO/RTOs strengthen and the ISO/RTOs' capabilities grow. ISO/RTOs are at different stages of evolution, driven by differing regional priorities and needs, so they do not all provide identical or fully consistent services at a given point in time. Organizations such as ERCOT and SPP have spent or will spend several years performing day-one grid management and planning services only without moving to day-two markets, while other ISO/RTOs began offering day-two market services relatively early on.

As an example of the impact of expanded services upon costs, consider the Western Electricity Coordinating Council. Although WECC is not an ISO or RTO, it is performing services similar to those provided by ISO/RTOs. WECC's board recently approved a 40-percent budget increase for 2006. WECC explains that this increase is needed to cover its growing core expenses, which include its reliability center (representing 37 percent of its total 2006 budget), NERC activities, training, and planning and analysis to deal with four major new transmission projects.³⁴

³⁴WECC Board-Approved 2006 Budget documents, October 2005 www.wecc.biz.

The Value of Independent Regional Grid Operators

Table 5							
Services Provided by ISOs and RTOs							
Services Provided	ISO-NE	NYISO	PJM	MISO	SPP	ERCOT	CAISO
Grid Operations	1997	1998	1997	2002	1997	1996	1998
Transmission Scheduling	Y	Y	Y	Y	Y	Y	Y
Regional Economic Dispatch	Y	Y	Y	Y	2006	Y	Y
Transmission Planning	1997	1999	1997	2002	1998	1997	2002
Regional Transmission Planning	Y	Y	Y	Y	Y	Y	Y
Regional Interconnection	Y	Y	Y	Y	Y	Y	Y
Transmission Cost Allocation Method	Y	Y	Y	N	Y	Y	Y
Wholesale Market Operations	1999	1999	1998	2005	2006	2001	1998
Real-time energy market	Y	Y	Y	Y	2006	Y	Y
Locational energy price	Y	Y	Y	Y	2006	2008-09	Y
Hourly energy price	Y	Y	Y	Y	2006	Y	Y
Congestion price	Y	Y	Y	Y	2006	Y	Y
Losses price	Y	Y	Cost	Y	2006	Y	Y
Day-ahead energy market	Y	Y	Y	Y	N	2008-09	2007
Virtual bidding	Y	Y	Y	Y	N	2008-09	N
Ancillary services market	Y	Y	Y	Cost	Cost	Y	Y
Regulation	Y	Y	Cost	Cost	Cost	Y	Y
Operating reserves	Y	Y	Y	Cost	Cost	Y	Y
Financial transmission rights	Y	Y	Y	Y	2006	Y	Y
Capacity market	Y	Y	Y	N	N	N	N
Settlements and billing	Y	Y	Y	Y	2006	Y	Y
Retail Market Operations						2001	
Renewable Energy Credits	N	N	N	N	N	Y	N
Retail customer registration	N	N	N	N	N	Y	N
Load profiling	N	N	N	N	N	Y	N
Data aggregation	N	N	N	N	N	Y	N
Market Oversight	1997	1999	1998	2005	2006	2004	1998
Independent market monitor	Y	Y	Y	Y	N	Y	Y
Market mitigation	Y	Y	Y	2005	2006	Y	Y
Y = yes, market-based Cost = cost rather than market-based payment '06 = year service will start							
Based on FERC 2004 State of the Markets Report, Tables 1 & 2, pages 51-52, and ISO/RTO data.							

ISO/RTO services don't appear out of thin air to be forced onto their members. An ISO/RTO develops its services in response to members and regulator requests, and designs the features of each service through an extensive stakeholder process to ensure that the service meets its members' needs and its region's characteristics. In most cases, the addition of major new services is accompanied by a formal cost-benefit analysis to be sure that the member and aggregate regional benefits of a major change has value in excess of its costs. For example, the NYISO has adopted formal capital budgeting guidelines recommended by its members requiring the NYISO to provide estimated cost-benefit analyses for all initiatives exceeding \$500,000. Most services must be approved by FERC (or, for ERCOT, the Public Utility Commission of Texas); significant changes directed by the regulator (including an expedited implementation date) may increase the costs of service provision. Following regulatory approval – during which the service proposal, purpose and design are fully considered by the regulator, usually with extensive input from the submitting ISO/RTO's members and stakeholders – the ISO/RTO begins working to implement the service. When a new service entails development of a new information systems platform, service start-up costs may be significant, but costs stabilize and fall as the service moves into full operation.

ISO/RTO cost factors

Several factors characterize ISO/RTO costs: costs are largely fixed for each ISO/RTO; a high proportion is related to highly skilled labor costs; and there is a heavy dependence on specialized information technology (IT) tools.

Reliability and market services rely upon a high level of fixed cost elements. The magnitude and quality of critical elements such as information technology (hardware and software such as EMS/SCADA and state estimators or market management and billing systems) and control room operators vary little with the volume of services provided – MWh flows, transactions processed, or customers served. For example, PJM's expansions in 2004-05 (integrating Commonwealth Edison, American Electric Power, Dayton Power and Light, Duquesne Light Company, and Dominion) caused its load to double, but its total costs increased by 45 percent while its cost per MWh of load served actually decreased nearly 30 percent from 2003 to 2005. In a business where economies of scale are potent, the size of the load served does not have a huge effect on the ISO/RTO's costs, but it directly affects the ISO/RTO's cost per MWh. As an ISO/RTO's load increases, it allows the entity to leverage its technology and labor across a larger group of beneficiaries.

A significant portion of ISO/RTO cost is driven by reliability operations – grid operator salaries and training, data management, SCADA/EMS, software licenses, computer hardware, and extensive telecommunications networks. PJM reports that 60 percent of its budget is driven by real-time grid operations and system planning (including IT support), while ISO-NE spends less than one quarter of its total budget on grid reliability (with more for associated IT). One factor affecting ISO/RTO reliability costs is the number of control rooms and back-up centers it operates and maintains for 24x7 reliable operations – a large regional footprint may require two control rooms, as well as back-up control rooms and fail-over computer systems for complete control redundancy. In California, a satellite control center is maintained nearly 400 miles away from the main operations center given the possibility of earthquake damage, and a high-reliability communications system links the two centers.

An ISO/RTO's level of market evolution also affects its costs, because many market services require complementary services. Once an ISO/RTO offers any market services – real-time, day-ahead, ancillary services or capacity market operation – it will soon need formal market monitoring, which can cost \$1 million or more per year. As real-time or day-ahead market trading volumes increase, market participants begin requesting credit screening and management services and settlement netting to facilitate transactions flows. Market operations also require a full suite of metering, settlement, billing, and auditing services, with supporting data management systems.

ISO/RTO IT applications are highly specialized and many are unique to the power industry.

As noted in the reliability section, ISO/RTO services depend heavily upon a sound IT platform. This has several implications for ISO/RTO costs:

ISO/RTO IT applications are highly specialized and many are unique to the power industry. These applications are offered by a limited number of vendors and development costs cannot be spread across a large user base. Furthermore, because there are few vendors, there is less inter-vendor competition to drive down software costs.

- Although most reliability software applications – state estimator, contingency analysis, EMS/SCADA – are relatively consistent across all ISO/RTOs and the wider utility community, most market applications are relatively specialized around the wholesale power markets’ characteristics. Because market software is highly customized around each ISO/RTO’s market design, it is more costly to design and develop than IT used in many other industries.
- The requirement that grid and market operations operate with very high levels of reliability around the clock places very high demands upon ISO/RTO IT systems and raises the costs for redundant hardware and software systems and support operations.
- Because so many ISO/RTO jobs require a high level of IT sophistication, the work force is highly skilled and requires a high level of training to maintain high expertise. Both factors raise ISO/RTO labor costs.
- Due to rapid technological change, many elements of IT hardware and software become obsolete quickly and require replacement within three to five years of initial purchase. To deal with this, more ISO/RTO software is being designed and built to evolve with market and reliability requirements, reducing costs relative to the alternative of full software replacement to meet changing functionality needs.
- ISO/RTOs manage a great deal of confidential information for their members. Appropriate IT security design and implementation can be costly given the rapid change in potential methods for cyber-security attacks.

A recent FERC staff study of ISO/RTO costs found that a significant amount of start-up costs for Day-One ISO/RTOs³⁵ are dedicated to pure reliability functions – both short-term tasks, such as OASIS information posting, transmission service operations, scheduling authority, Available Transmission Capacity determinations, outage coordination, redispatch for congestion, ancillary services coordination, and parallel flow mitigation, and longer-term responsibilities, such as planning, interregional coordination and market monitoring. The FERC report concluded that, “the direct impact of a new Day-One ISO/RTO should be less than one-half of one percent of a retail customer’s bill,” approximately 0.02 cents/KWh or \$2.31 per year for a typical retail customer.³⁶ FERC staff further noted that when the ISO/RTO begins performing grid operations tasks such as scheduling, system control and load dispatch, it displaces costs for such operations now being performed by numerous control areas and transmission owners.³⁷

³⁵FERC defines Day-One services as including “open access transmission service, scheduling authority, available transmission capacity determination, redispatch for congestion management, ancillary services provision, planning, parallel path flow mitigation, interregional coordination and market monitoring.” Day-Two functions include some combination of real-time and day-ahead energy markets based on “bid-based, security-constrained economic dispatch, unit commitment, locational prices, financial transmission rights, and capacity market operation.” Federal Energy Regulatory Commission Staff, “Staff Report on Cost Ranges for the Development and Operation of a Day-One Regional Transmission Organization,” October 2004, at i.

³⁶FERC Staff Report, op cit, at ii.

³⁷Op cit. at 23.

A study on information technology guidelines for power system operators, prepared by Gestalt LLC for FERC,³⁸ found that there are significant increases in cost and complexity to develop a system operator from control area functions to reliability coordinator functions (which include some of the FERC Day One RTO tasks) to Market Administration (the remaining FERC Day One and Day Two RTO functions). Required technology investments increase substantially as the functions increase in complexity and responsibility.³⁹ Those who complain about the current costs of RTOs relative to control areas' past costs neglect to consider the vast difference between the scale, scope and functions that RTOs perform relative to those performed by control areas or reliability coordinators.

IT costs add up. NYISO spends approximately 30 percent of its total budget for IT, and this level will increase with hardware replacement needs. The California ISO spends 32 percent of its total budget on IT, the majority for software and hardware maintenance and telecommunications; software development costs for the California ISO's new market design are counted separately. PJM spends 40 percent of its corporate budget on IT.

This level of technological sophistication produces a very high level of benefits, as discussed previously. The result is that ISO/RTOs can reliably maintain very high transactions and data management levels. For perspective, consider that PJM processes more than nine million transactions per minute, moves 70 kilobytes per second across its communications and IT network, and stores about 70 terabytes of data. These volumes of information handled are equivalent to those handled by VISA, the credit card transactions processor. ERCOT's 400 servers process seven terabytes of data per day. Monthly, ISO New England's Web site receives 67 million hits and serves 28 million pages of information.

ISO/RTO cost management

ISO/RTOs work carefully to contain costs and manage their budgets. With reliability and market services stabilizing, the costs are stabilizing as well. Some of the cost management techniques include:

- Managing the balance of internal employees versus consultants and vendors for new software development;
- Negotiating telecommunications and networking arrangements and providers to achieve multi-million dollar cost reductions;
- Evaluating lease versus purchase options for computer hardware acquisition;
- Designing IT architecture for long-term sustainability, to support more cost-effective software evolution;
- Increasing stakeholder participation in market planning to assure that the labor and other software development costs of wholesale market changes can be effectively phased and managed;
- Setting and keeping careful limits on software-driven capital and operations expenses; and
- Monitoring costs of peers and adopting best practices.

After seven years of operation, the California ISO recently announced it will roll back its Grid Management Charge by 15 percent in 2006, with another 30 percent drop by 2010. As the not-for-profit public benefit corporation pays off the debts incurred during start-up and market redesign, its fees should fall to around 60 cents per MWh with no reduction in service. PJM has proposed to use a "stated rate," asking FERC to

³⁸Federal Energy Regulatory Commission Staff Report on Information Technology Guidelines for Power System Organizations," Gestalt, LLC, April 2005.

³⁹Op cit at 21-39.

approve its cost tariff as a charge for services that will be fixed at a flat rate (less than \$0.40/MWh) for five years, to establish budget and cost stability for both the RTO and its members at rates below 2002 levels. ISO-NE implemented a long-term finance strategy that disciplines the capital expenditure program by requiring funding for new investment to be provided from funds recovered for depreciation. As a result, the capital expenditure program for the next nine years is planned to be at 50 percent of 2002 spending levels. NYISO created five-year budget targets in 2003 for the period 2004 to 2008 that should limit aggregate annual budget increases to only two percent over the five-year period.

ISO/RTOs are using the principles of standardized technology development and common architectures in several initiatives today. The grid operators are formally coordinating their efforts in the areas of operations and grid reliability, finance, legal, communications and information technology, to learn from each other and lower costs. One of the most exciting initiatives involves joint development of grid visualization tools, used by system operators to monitor and manage grid conditions in real time. In an effort to help control room operators maintain reliability, the ISO/RTO Information Technology Committee is developing common specifications and exploring new technologies for control room display boards. The committee is also working closely with the leading EMS software vendors to develop a common architecture for EMS and related reliability software elements, which will improve inter-operability between vendors' products, reduce the costs of EMS quality improvements and thus enhance grid reliability. ISO/RTOs are also collaborating on a web-server investment project to facilitate transmission schedule verification procedures.

Challenges ahead

Now that the pace of change has slowed and operational efficiencies are being realized, the greatest challenge for ISO/RTOs is to continue creating value for their members. In the process of creating this additional value, ISO/RTOs will continue to work with regulators and stakeholders to stabilize and refine the information technologies that make up the bulk of their operating costs.

8 Conclusions

This paper has reviewed the high-value services that ISO/RTOs provide, from reliability, operational efficiencies, grid planning and open access to market operation. Few of these services can be performed by an entity other than an ISO/RTO because of the need for technological sophistication, a large geographic footprint, and access to resources to develop innovative new technologies and services for member benefit. The total value of these services and the savings and efficiencies they bring to America's electricity markets far exceeds the funds that ISO/RTOs spent to provide these services – and as ISO/RTOs mature and work together more effectively, their per-unit costs of doing business are declining.

APPENDIX A ISO/RTO COST DETAILS

Figure A-1 shows ISO/RTO costs as a function of revenue requirement per unit of load served. This shows that while per-unit costs increased in the early years as each ISO/RTO began building its capabilities and experience, those costs have leveled off or dropped as the organizations and their offerings are stabilizing. It also shows a marked distinction between the ISOs and RTOs serving relatively smaller footprints and loads (New England, New York and California) relative to those providing grid and market services to large footprints and loads (ERCOT, Midwest ISO and PJM). While the costs per MWh are quite similar within each group, the smaller ISO/RTOs have relatively higher costs per MWh because they have fewer units to spread their fixed costs across. That said, the value of the benefits delivered by these companies exceeds the costs incurred resulting in a positive cost/benefit ratio. Analysis performed by ISO-NE reveals the cost/benefit ratio to be 1:7, meaning \$1 spent returns \$7 of benefits.

Figure A-1
ISO RTO Costs per Megawatt-hour of Load Served
(\$/MWh)

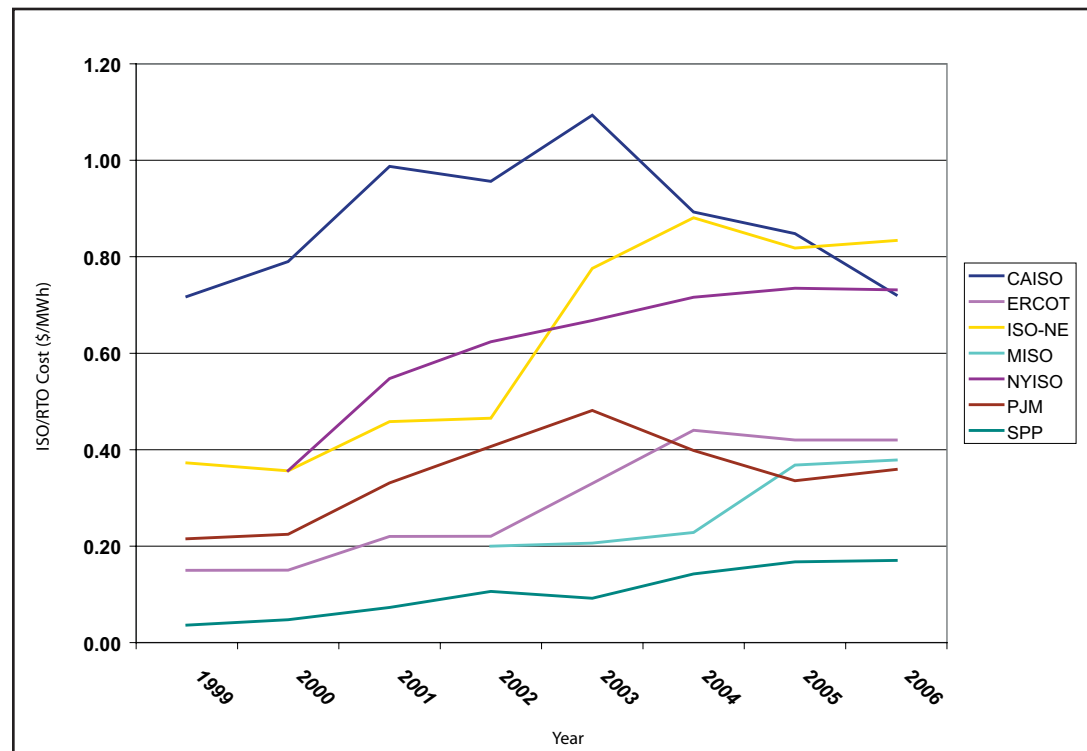

The Value of Independent Regional Grid Operators

Total ISO/RTO costs offer other insights. Figure A-2 shows ISO/RTO revenue requirements since 1999. It shows that costs increase as services increase (as with the Midwest ISO, SPP, and the PJM expansions); that costs flatten as the organization matures and its services stabilize (as with NYISO, ISO-NE, and ERCOT); that ISO/RTOs with large footprints and loads (PJM and the Midwest ISO) have higher costs than small ones (ISO-NE, NYISO, and ERCOT); and that small ISOs have similar cost profiles (again, ISO-NE, NYISO and ERCOT).

Figure A-2
Annual Revenue Requirements for ISOs and RTOs

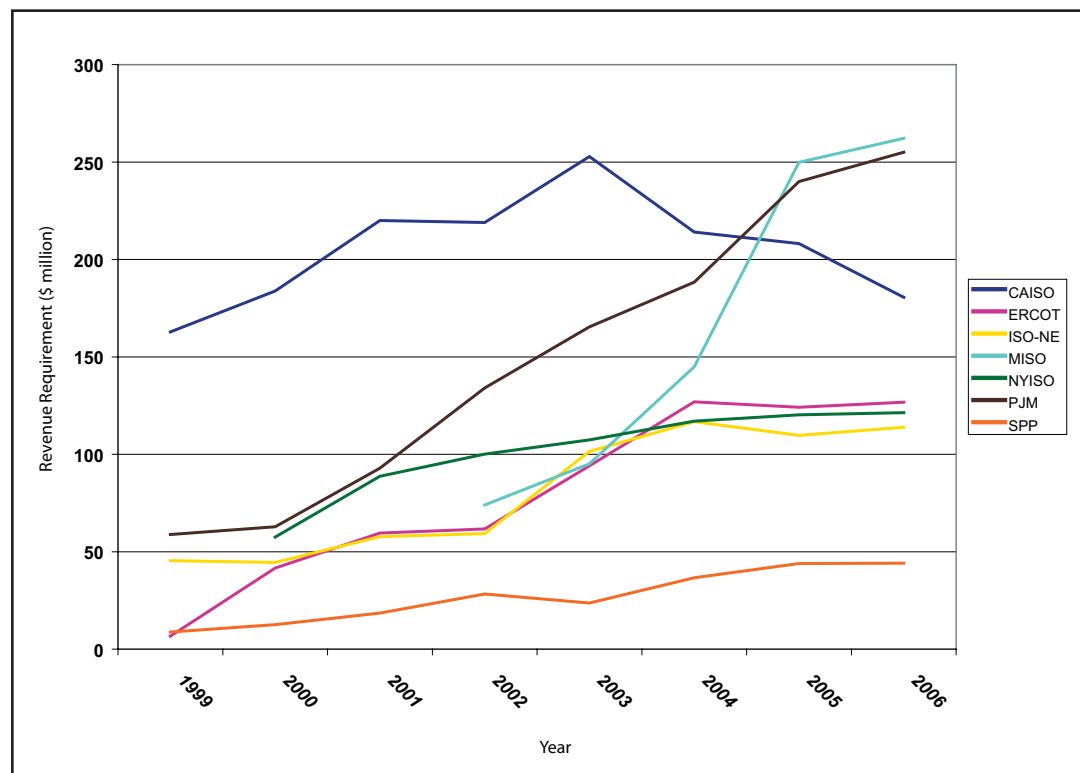



Submission Contents

Comments of the ISO/RTO Council ISORTOCouncilComments.pdf.....	1-30
Attachment (RTO White Paper) to the Comments of the ISO/RTO Council Attachment-IRCWhitePaper.pdf.....	31-76