

Enhanced Day-Ahead Commitment Operations DWG – Detailed Design Elements

Bringing It All Together
July 8, 2009



- Provide DWG Stakeholders with an overview of the EDAC Detailed Design Elements discussed to date
- Slides have been revised to reflect design changes since last presented to the ODWG
- Changes will be discussed during the presentation

- EDAC Objectives and Benefits
- PCG Eligible Resources
- Pseudo Unit Model Definition
- Enrolment Requirements
- EDAC Data Submission Requirements
- Data Submission Prior to **Optimization**
- Linked Wheels
- EDAC **Optimization Process**

- EDAC Calculation Engine Initialization at Midnight Boundary
- EDAC Calculation Engine
- Data Submission During **Optimization**
- Reporting and Notifications
- EDAC Results Integration In Real Time
- Data Submission in Real-Time
- Withdrawal and De-commit

Objectives and Benefits



Enhanced DACP improves efficiency of current process for scheduling/committing resources required to provide electricity on a daily basis by optimizing existing and anticipated generation more effectively while maintaining system reliability

- Optimizes energy and operating reserve over a 24 hour dispatch day
- Optimizes using 'total' costs for committable generators (start-up, speed-no-load, and incremental energy costs via three part offers)
- Inclusion of exports and linked wheel transactions
- Inclusion of combined-cycle modelling

Production Cost Guarantee Eligible Resources



- A dispatchable generator will be deemed eligible for DA-PCG if:
 - not a quick start facility; **and**
 - has a minimum loading point greater than zero; **and**
 - has a minimum generation block run-time greater than one hour; **and**
 - has a need to initiate start up sequences greater than one hour in advance of the hour in which they first receive a schedule, in order to respond to a dispatch associated with their constrained schedules.

- Three-part offers include:
 1. Start-Up – value to bring generator up to minimum loading point (may also include amounts associated with ramp down from minimum loading point) - \$ per start
 2. Speed No-Load – notionally the cost to maintain a generator synchronized with zero net energy injected into the system - \$ per hour
 3. Incremental Energy – energy offers for entire operational range of generator - \$/MWh

Thee Part Offer and Cost Terms

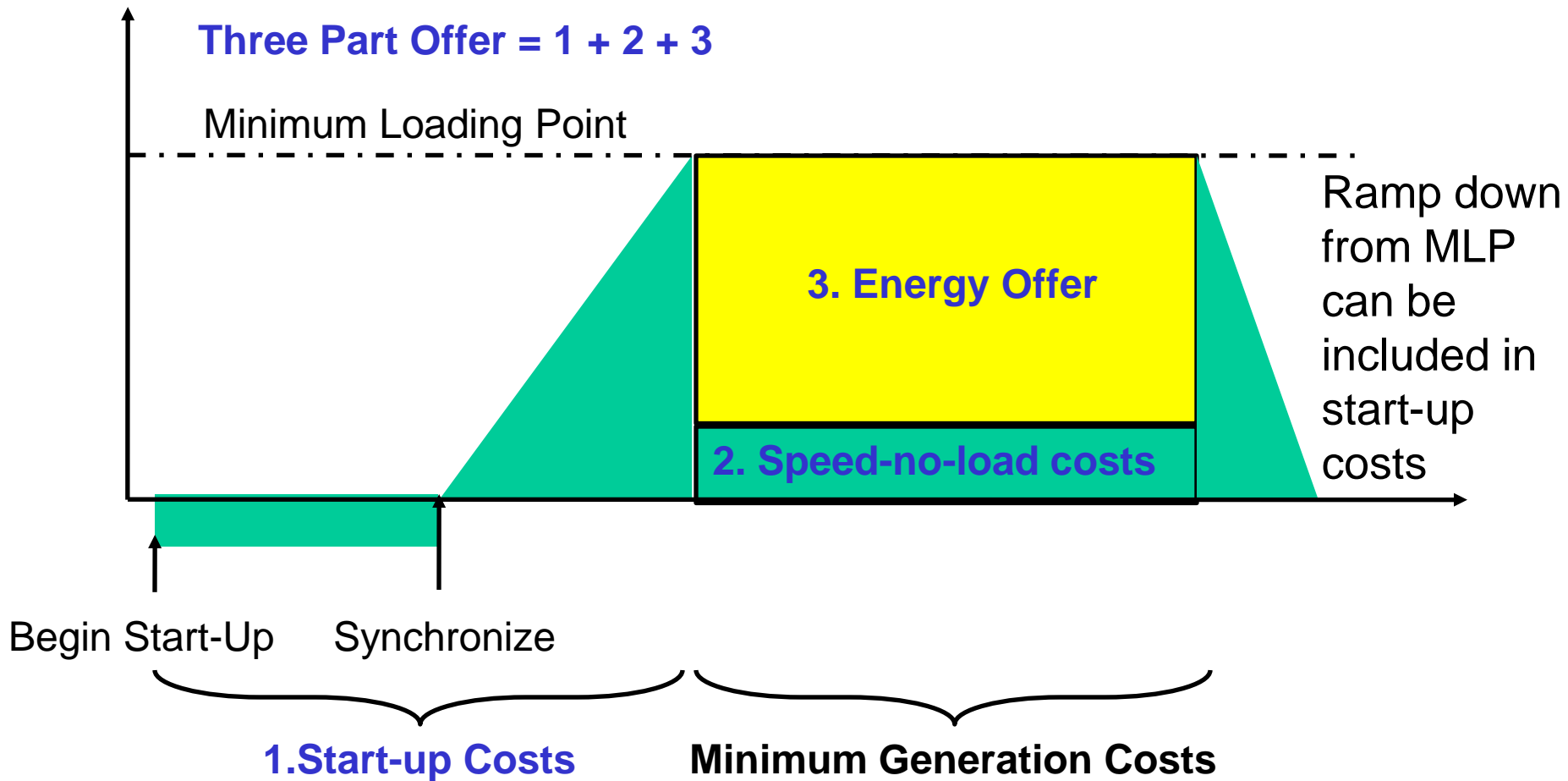

 Fixed Costs

Pseudo Unit Model Definition



The EDAC Pseudo-Unit (PSU) model represents a Combined Cycle Plant (CCP) with one or more Combustion Turbines (CT) and a single Steam Turbine (ST) as one or more PSUs, each comprised of a single CT and its associated portion of the ST capacity

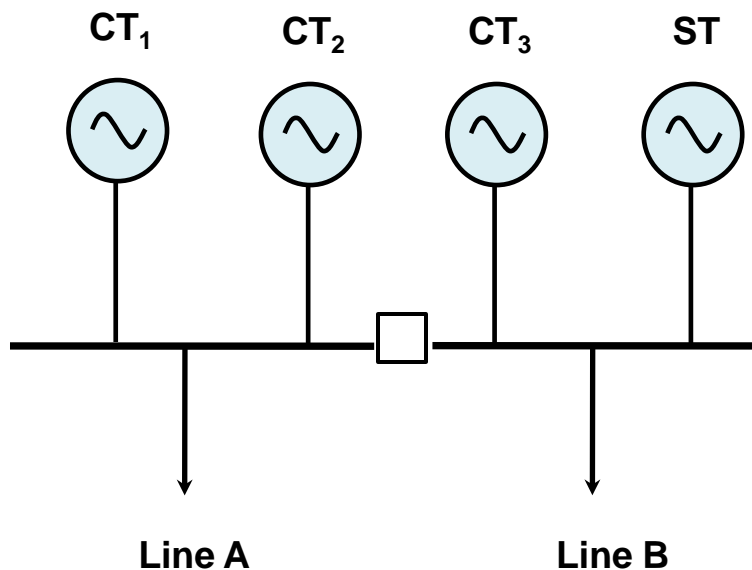

Physical Units

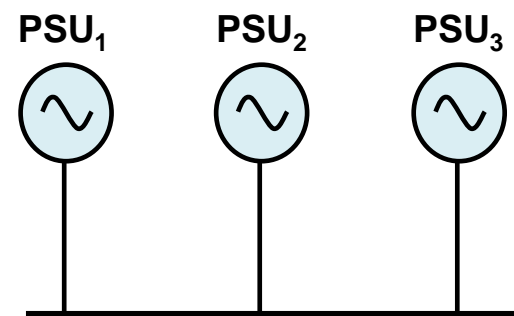

$$PSU_1 = CT_1 + 1/3 ST$$

$$PSU_2 = CT_2 + 1/3 ST$$

$$PSU_3 = CT_3 + 1/3 ST$$

Pseudo Units

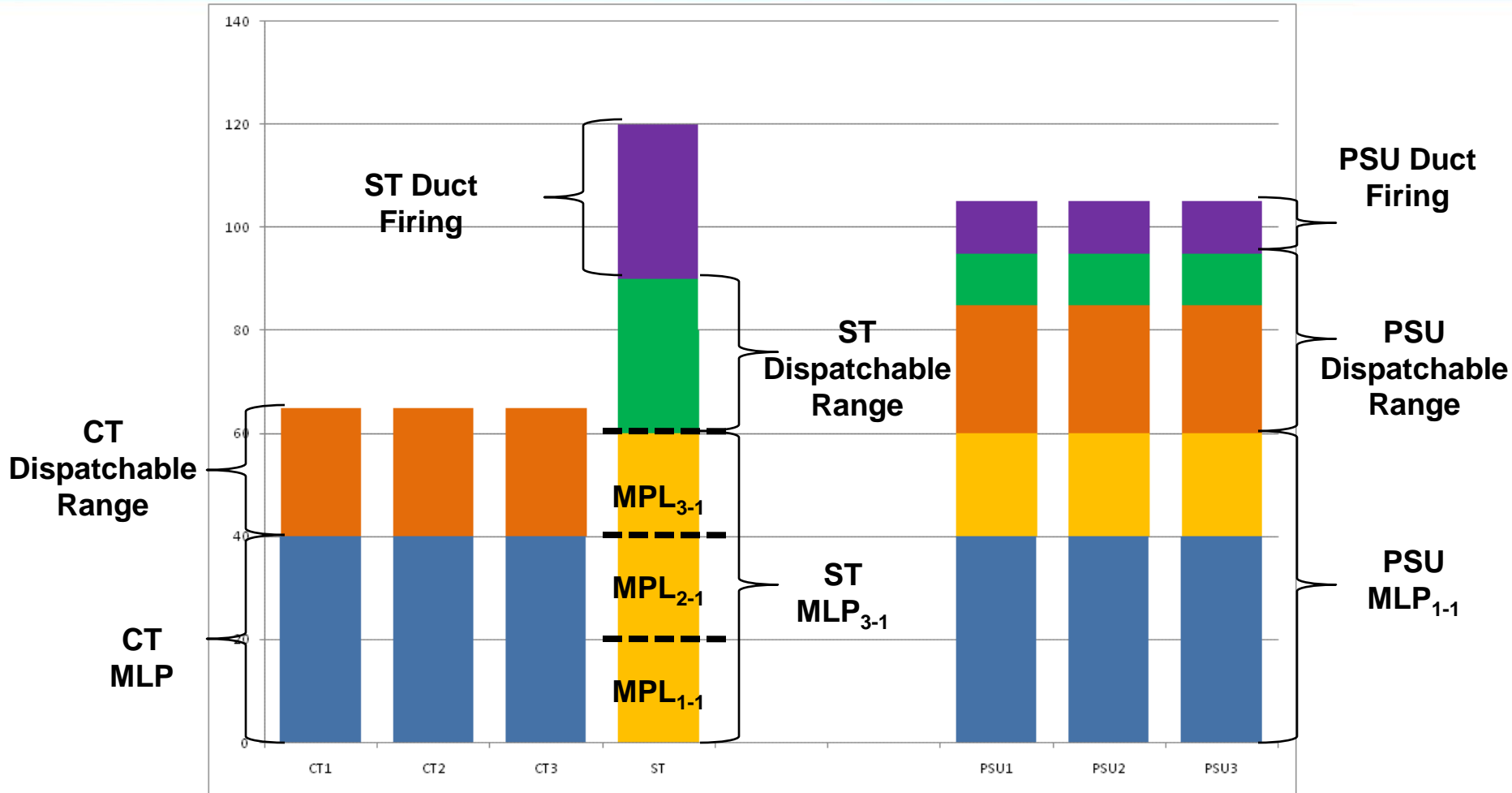

Physical Units

Pseudo Units

- Offered into EDAC using three-part offers that are specific to the pseudo unit
 - Offers for CT and ST physical resources associated with a pseudo unit will be ignored during EDAC timeframe
 - Incremental energy offers (P,Q pairs) cannot cross sharing regions
- Optimized as any other non-quick start resource offered day-ahead
- The maximum output of the PSU offer will be limited by de-ratings or outages to the physical CT and ST resources, and transmission limitations
- EDAC commitments and constraints to PSUs will be translated to physical CT and ST for use in real-time
 - ST constraint will reflect scheduled PSU configuration, and will equal $MLP_{N-1,\dots}, MLP_{2-1}, MLP_{1-1}$

Enrolment Requirements



- EDAC calculation engine will respect the physical characteristics of generation resources
- Static physical characteristics will be registered through Market Entry
 - Variable physical characteristics will be recorded into daily generator data and may be overwritten daily if equipment or regulatory conditions warrant
- Changes to registration data will be implemented within 6 business days
 - Registration data will be captured using existing forms, where possible

- EDAC related registration data include:
 - MLP & MGBRT (already being registered)
 - MLP Limit
 - MGBRT Limit
 - Dispatch Elapsed Time
 - Minimum Hydraulic Time Lag
 - Combined Cycle Data – ST MLP_{n-on-1} Limit
 - Pseudo Unit Data (~~covered in PSU section~~)

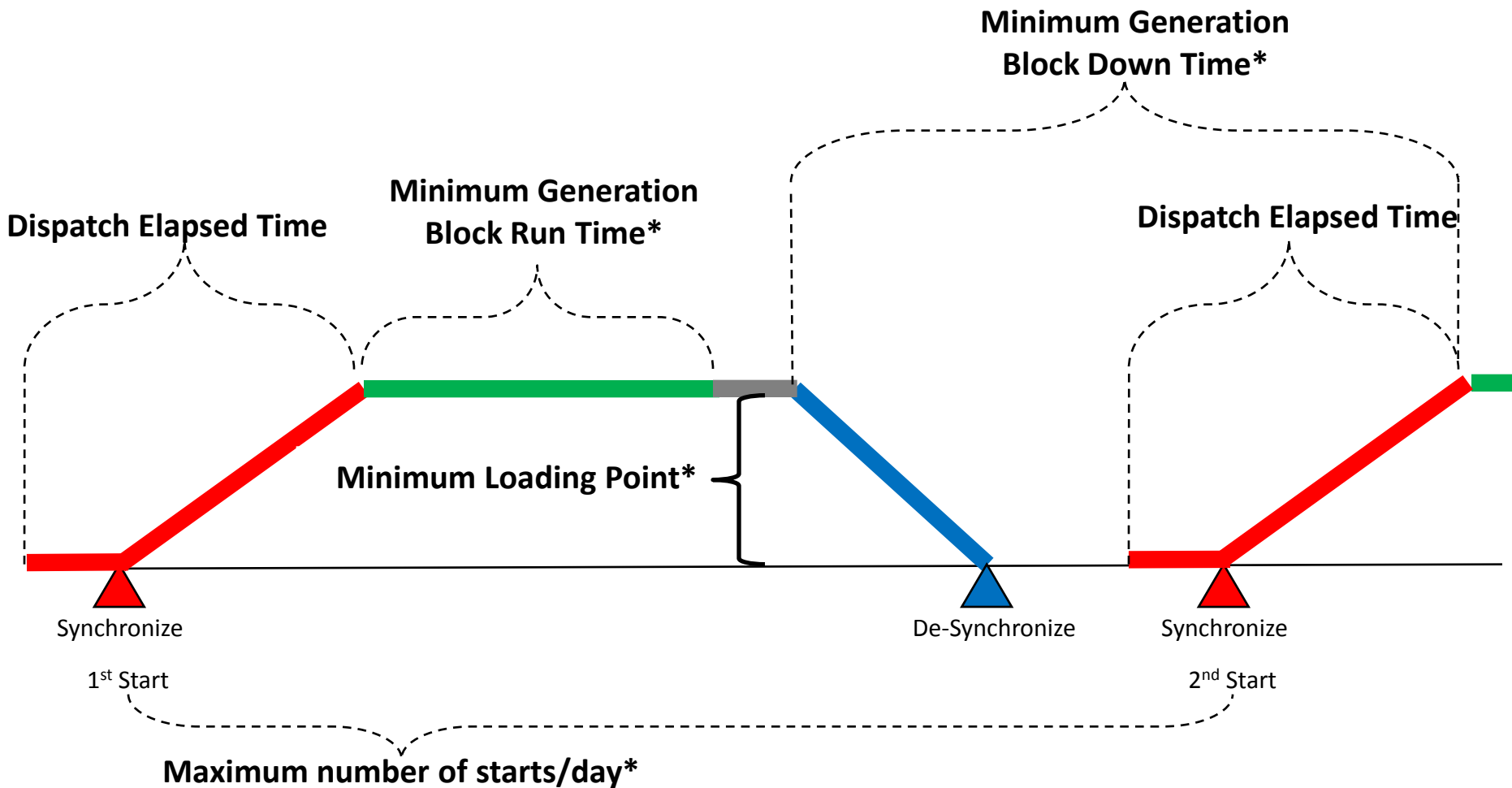

***daily values submitted through Daily Generator Data**

- Captured on Form 1552 today
- Validation rules:
 - Generator must not be a quick start generation unit
 - Number format XXX.X MW
 - A single registered quantity for each resource
 - $0 \leq \text{MLP} \leq \text{Maximum generator capability}$
 - Must reflect the technical capability of the generator
 - All resources that have a technical requirement for MLP must submit this quantity to the IESO

- The MLP Limit is the highest MLP that is required for anticipated operating conditions
- MLP Limit is intended to cover operating conditions that are regularly encountered but not all *possible* operating conditions.
- MLP Limit is used to validate DGD MLP submissions, will be registered on Form 1552
 - DGD MLP is recorded into daily generator data and may be overwritten daily if equipment or regulatory conditions warrant

- MLP Limit will be used to provide a range by which day ahead changes will be evaluated for approval
- If $MLP_{(DGD)} \leq MLP \text{ Limit}$
 - it will be automatically approved
- If $MLP_{(DGD)} > MLP \text{ Limit}$
 - Automatically approved and flagged for compliance review

- Captured today on Form 1552
- Validation rules:
 - Generator must not be a quick start generation unit
 - Number format XX hours (integer)
 - A single registered quantity for each resource
 - $0 \leq \text{MGBRT} \leq 24$
 - Must reflect the technical capability of the generator
 - All resources that have a technical requirement for MLP must submit this quantity to the IESO
 - If no MLP is registered, no MGBRT can be registered

- The MGBRT Limit is the highest MGBRT that is required for anticipated operating conditions
- MGBRT Limit is intended to cover operating conditions that are regularly encountered but not all *possible* operating conditions.
- MGBRT Limit is used to validate daily generator data submissions, will be registered on Form 1552
 - MGBRT is recorded into daily generator data and may be overwritten daily if equipment or regulatory conditions warrant

- MGBRT Limit will be used to provide a range by which day ahead changes will be evaluated for approval
- If $MGBRT_{(DGD)} \leq MGBRT \text{ Limit}$
 - it will be automatically approved
- If $MGBRT_{(DGD)} > MGBRT \text{ Limit}$
 - Automatically approved and flagged for compliance review

- Dispatch Elapsed Time is the minimum amount of time, **in minutes**, between the time at which a generator initiates its start-up sequence and the time at which it can respond to IESO dispatch signals
 - For a non-quick start, this means that the generator has reached MLP
- Must be submitted by all dispatchable generators, will be registered on Form 1181
 - This applies to existing resources as well as newly registered resources

- This is a new definition for EDAC
- Validation rules:
 - Must reflect the technical capability of the resource
 - Number format xxx minutes (integer)
 - A single registered quantity for each resource
- **Quick Start Flag Determination**
 - If Dispatch Elapsed Time > 5 minutes **then** Quick Start Status = N
 - If Dispatch Elapsed Time ≤ 5 minutes **then** Quick Start Status = Y

- This is a new definition for EDAC
- Validation rules:
 - The selected value for Registered Resource Fuel Type must = 'WATER'
 - Number format xx hours
 - The entered value must be ≥ 0 ~~and~~ < 24
 - Mandatory entry for any resource that is has a cascading hydroelectric dependency
 - Entry prohibited if Registered Resource Fuel Type is not 'WATER'

- **Eligible Energy Limited Resources (EELRs)** are cascading hydroelectric generation facilities with registered water travel time (minimum hydraulic time lag) between upstream or downstream plants of less than 24 hours will be allowed to resubmit for this purpose (based on Minimum Hydraulic Time Lag submission)
- **Eligible Energy Limited Resource Determination**
If $0 \leq \text{Minimum Hydraulic Time Lag} < 24$ and Fuel Type = 'WATER'
Then EELR Status = Y
Otherwise EELR Status = N

ST Minimum Loading Point Limit (2-on-1, 3-on-1, ... n-on-1)

- Submission includes specification of the Combustion Turbines and Steam Turbine (Resource Name & ID that are a part of the combined cycle facility)
- Registered MLP_{n-on-1} Limit specify the highest MLP that is required for anticipated operating conditions based on n-on-1, CT-on-ST scheduled configuration
- MLP_{n-on-1} Limit is intended to cover operating conditions that are regularly encountered but not all *possible* operating conditions.
- MLP_{n-on-1} Limit is used to validate **Combined Cycle** ST Unit Daily Generation Data MLP_{n-on-1} submissions
- MLP_{n-on-1} Limit will be captured on a new/revised IESO Form
- If EDAC MLP_{n-on-1} (DGD) > MLP_{n-on-1} Limit, DGD revision will be flagged for compliance review

- Physical Unit registration data will be captured using existing forms
 - Physical registration is as documented in Facility Registration, Maintenance and Deregistration Procedure
 - Physical resources must not be aggregated
- Pseudo Unit registration data will be captured using a new/revised IESO Form
 - Registration includes all physical resources (all CT's with an output relationship with ST)
- Changes to registration data will be implemented within six business days
 - Variable physical characteristics will be recorded into daily generator data and may be overwritten daily if equipment or regulatory conditions warrant

- Market Participants using the PSU model in EDAC must register with the IESO:
 1. Physical facilities:
 - a. CT *generator* Resource(s)
 - b. ST *generator* Resource
 2. CT and ST Resource association per PSU Resource
 3. Duct Firing Capacity available on the ST
 4. ST Capacity Share Percentage per PSU Resource
 5. **ST Minimum Loading Point Limit (2-on-1 and 3-on-1)**

*PSU registration of items 2 through 5, will be through a form for Pseudo Unit Parameters

Physical unit registration data (both ST and CT) used by the PSU will include:

1. Maximum Capacity Rating (MCR)
2. Minimum Loading Point Limit (1-on-1)
3. Minimum Generation Block Run Time Limit
4. Market Type (Energy, Operating Reserve markets)
5. Resource Type (Dispatchable, Self-Scheduling)
6. Registration Parameters associated with determining PCG eligibility

*PSU characteristics for items 3 through 6, will be based on those of the CT

CT and ST Association per PSU Resource

- Submission includes specification of the Combustion Turbine and Steam Turbine (Resource Name & ID that will make up each PSU Resource)
- Value will be captured on a new/revised IESO Form
- Based on submission a relationship between physical and pseudo resources is established
 - Relationship is used for calculation/validation of group PSU parameters, and translation and transfer of PSU schedules into physical equivalents
 - Physical resources associated with a PSU receive a flag identifier for the purposes of ignoring of physical offers during EDAC
 - Pseudo unit receive a flag identifier for the purposes of ignoring of pseudo unit offers outside of EDAC

- Submission specifies the amount of capacity that is generated from duct burner operation
- Required for calculation of Steam Turbine operating range that is dependant on Combustion Turbine output
- Value will be captured on a Form
- Validation rules:
 - Number format xxx.x MW
 - Must reflect the technical capability of the steam turbine generator

- Registers the percentage of Steam Turbine capacity that should be allocated to PSU Resource
- Percentage value determines that amount of:
 - ST capacity that is contributed to each PSU resource
 - Duct Firing component that is contributed to each PSU resource
- Value will be captured on new/revised IESO Form
- Validation rules:
 - Sum of ST shares to all PSUs at one facility must be 100%
 - Must reflect the technical capability of the generator
 - Expressed as a percentage of ST maximum capability
 - Number format XXX.X %

- EDAC will continue to use the Pseudo Unit model to schedule Combustion and Steam resources associated with a registered Pseudo Resource, until the time of de-registration.
- Market participant submits request for Pseudo Unit Facility de-registration to the IESO
 - Provided that physical units are not being de-registered, no technical assessment will be required
- De-registration includes all pseudo unit resources at a combined cycle plant

- Once de-registered:
 - Physical resources will be scheduled individually according to economic merit (independent of proportions of gas and steam outputs)
 - CTs in Schedule of Record will be constrained to the MLP submitted in the daily generation data
 - ST constraints will reflect the scheduled CT configuration in Schedule of Record, and will equal MLP_{N-1} provided that N number of CTs were scheduled and the ST was in the Schedule of Record for at least the MLP_{N-1} amount
 - If the ST is not scheduled up to MLP_{N-1} it will receive a constraint to the next lowest MLP configuration that was scheduled
 - If the ST is not scheduled above MLP_{1-1} it will not receive a constraint

EDAC Data Submission Requirements



- EDAC Data types
 - Enrolment data (previously covered)
 - Daily Generator Data
 - Dispatch Data

Data Type	Data Description	Unit/Update Frequency	Resource Type							
			Dispatchable Generators DET > 1Hour	Dispatchable Generators 5 Min < DET ≤ 1Hour	Pseudo Units	Dispatchable Generators DET < 5 Min	TSG, INT/S Generators	Dispatchable Load	Imports	Exports
Dispatch Data	Start-Up Cost	\$/Start/daily	X	X	X					
	Speed No-Load Cost	\$/h/daily	X	X	X					
	Incremental Energy Bid	\$/MWh/daily						X		X
	Incremental Energy Offer	\$/MWh/daily	X	X	X	X		X	X	
	Incremental Energy Quantity	MWh/ daily	X	X	X	X		X	X	X
	Incremental OR Offer	\$/MWh/ daily	X	X	X	X		X	X	X
	Incremental OR Quantity	MWh/ daily	X	X	X	X		X	X	X
	Energy Ramp Up	MW/min/ daily	X	X	X	X				
	Energy Ramp Down	MW/min/ daily	X	X	X	X				
	OR Ramp Up	MW/min/ daily	X	X	X	X				
Daily Generator Data	Energy Limit	MWh/daily	X	X	X	X				
	Schedules and Forecasts	MWh/daily					X			
	Minimum Loading Point	MWh/daily	X	X						
	Minimum Down Time	Hours/daily	X	X						
	Min Gen Block Run Time	Hours/daily	X	X						
Registration Data	Max Number of Starts	#/daily	X	X						
	Single Cycle Flag (CT Only)	Y/N / daily	X							
	Dispatch Elapsed Time	Minutes/Weekly	X	X		X				
	Minimum Hydraulic Time Lag	Hours/Weekly				X				
	MLP	MWh/Weekly	X	X						
	MGBRT	Hours/Weekly	X	X						
	MLP Limit	MWh/Weekly	X	X	X					
	MGBRT Limit	Hours/Weekly	X	X	X					
	PSU Association	Relationship/Weekly			X					
	PSU - ST Capacity Contribution (share) to Each CT	%/weekly			X					
Miscellaneous Data	ST MLP Limit (2 on 1, 3 on 1...)	MW /weekly			X					
	ST Duct Burner Capacity	MW/weekly			X					
	NERC Tag Identifier	Tag code/daily							X	X
	Market Scheduling Point and Boundary Entity Resource	POR/POD/daily							X	X
Miscellaneous Data	AGC Offers	Price/quantity/daily	X	X		X				
	SMO Outage Requests	Times/daily				X				

Daily Generator Data

- Generator data that can be updated on a daily basis in EDAC only:
 - Minimum Loading Point (MLP)
 - Minimum Generation Block Run Time (MGBRT)
 - Minimum Down Time
 - Maximum Number of Starts per Day
 - Single Cycle Mode (CT Only) Flag
- Submission in an electronic format
- Validation will be performed on submission
- Last submitted value is default value
- Tool Validation for MLP and MGBRT follows same rules as Enrolment

- Submission of Daily Generator Data:
 - DGD updates can be submitted at any time – EDAC will use the last submitted value
 - All DGD updates after 10:00 will be used on the next EDAC day
 - DGD updates above the MLP & MGBRT Limit (established at registration) will be flagged to compliance for review
 - ~~– All DGD updates between after 10:00 & 14:00 will be flagged to compliance for review used on the next EDAC day~~
 - ~~– DGD updates after 14:00 will be used for the next days EDAC run (unless revised)~~

Maximum Number of Starts per Day

- Maximum number of starts per day is the number of times that a generation unit can be started up within a day.
- The Maximum Number of Starts per Day is a single value for all hours the EDAC day. The data will be validated on submission based on the following validation rules:
 - Must not be a quick start generation unit
 - Number format xx starts
 - Must be a non-negative integer
 - Maximum of one quantity (applied to all hours of the EDAC day)
 - Must be $0 \leq \text{Max Starts} \leq 24$

Minimum Generation Block Down Time

- **Minimum Generation Block Down Time** is defined as the minimum time, in hours, between the time a generator is last at its minimum loading point before de-synchronization and the time the generator reaches its minimum loading point again after synchronization.
- The Minimum Down Time is a single value for all hours of the EDAC day. The data will be validated on submission based on the following validation rules:
 - Must not be a quick start generation unit
 - Number format xx hours
 - $0 \leq \text{MGBDT} \leq 24$
 - Must be a non-negative integer
 - Maximum of one quantity (applied to all hours of the EDAC day)

- submitted by market participant, allows MP to manage resource on physical level
- CT related entries include:
 - Minimum Loading Point (MLP)
 - Minimum Generation Block Run Time (MGBRT)
 - Minimum Generation Block Down Time (MGBDT)
 - Maximum # of Starts per Day
- ST related entries include:
 - Minimum Loading Points (MLP_{1-on-1} , MLP_{2-on-1} , MLP_{3-on-1} , MLP_{4-on-1}),
also applicable to ST at a Combine Cycle facility that is not part of a PSU
- Combined Cycle vs. Single Cycle
 - Combined Cycle Mode Flag
- MLP and MGBRT entries validated against registered limits

- Checkbox available on daily generator data of a combustion turbine resource that has been registered and associated to a pseudo unit
- Checkbox allows the combined cycle operator to toggle between single cycle and combined cycle mode for a PSU
- When selected for single cycle mode, the downstream calculations (PSU Calculated Parameters and PSU Sharing Data) for the pseudo unit resource associated with the CT will ignore any ST contribution
- Used when the combined cycle operator is aware of a ST derating or transmission limitation that limits the scheduling of the ST

- Whether the PSU can be scheduled depends on the magnitude of the ST de-rating.
 - If the ST de-rated capacity associated with a PSU is below the MLP_{1-1} , a PSU operating in combined cycle mode will not receive a schedule (cannot schedule the correct gas-to-steam proportions for the PSU_MLP)
 - In the same situation a PSU operating in single cycle mode will be scheduled independent of ST availability ($PSU_MLP = CT_MLP$)
- Only PSU's scheduled in Combined Cycle mode will count toward MLP commitments placed on ST due to scheduled configuration

- Calculated by the IESO based on Market Participant submission of registration data and daily generation data

- Entries include:

- Maximum Capacity Rating

$$\mathbf{PSU_{(n)}MCR = CT_{(n)}MCR + (ST_MCR \times ST_{(n)}Share\%)}$$

- Minimum Loading Point (MLP_{1-on-1})

$$\mathbf{PSU_{(n)}MLP = CT_{(n)}MLP + ST_MLP_{1-1}}$$

- Minimum Generation Block Run Time (MGBRT)

$$\mathbf{PSU_{(n)}MGBRT = CT_{(n)}MGBRT}$$

- Minimum Generation Block Down Time (MGBDT)

$$\mathbf{PSU_{(n)}MGBDT = CT_{(n)}MGBDT}$$

- Maximum # of Starts per Day

$$\mathbf{PSU_{(n)}Max\#ofStarts = CT_{(n)}Max\#ofStarts}$$

- Provides capacity contributed proportions between CT and ST across Pseudo Resource operating range
- Calculated by the IESO based on Market Participant submission of registration data and daily generation data
- Entries include:
 - Both Operating Range Amount (MW) & ST Proportion Percentage for:
 - a.) PSU Minimum Loading Point (MLP_{1-on-1}) Range
 - b.) PSU Dispatchable Range
 - c.) PSU Duct Firing Range
- Values used to translate pseudo unit schedules to physical resource schedules

PSU Minimum Loading Point Range	Range Quantity (MW)	$CT_{(n)}MLP + ST_MLP_{1-1}$
	ST Share (%)	$ST_MLP_{1-1} \div (CT_{(n)}MLP + ST_MLP_{1-1})$
PSU Dispatchable Range	Range Quantity (MW)	$CT_{(n)}MCR + ((ST_MCR - ST_DuctFiring) \times ST_{(n)}Share\%) - CT_{(n)}MLP - ST_MLP_{1-1}$
	ST Share (%)	$((ST_MCR - ST_DuctFiring) \times ST_{(n)}Share\% - ST_MLP_{1-1}) \div (CT_{(n)}MCR + ((ST_MCR - ST_DuctFiring) \times ST_{(n)}Share\%) - CT_{(n)}MLP - ST_MLP_{1-1})$
PSU Duct Firing Range	Range Quantity (MW)	$ST_DuctFiring \times ST_{(n)}Share\%$
	ST Share (%)	100%

- First operating region (Lower Region) must represent the region between 0 and PSU MLP
- Second operating region (Middle Region) must represent the region between PSU MLP and PSU capacity without ST share for duct firing
- Third operating region (Upper Region) must represent the region between upper bound of Middle Region and PSU maximum capacity (not required if the plant has no duct firing capabilities)
- The MW sum of all ST shares to the PSU operating regions must be equal to the MW value of the maximum ST contribution share to the PSU
- Similarly, the MW sum of all CT shares to the PSU operating regions must be equal to the MW of the maximum CT contribution to the PSU

Pseudo Unit - Example of Calculation Spreadsheet

Physical Unit Registration Data

Resource Type	Physical Facility				
Technical Data	CT1	CT2	CT3	CT4	ST
Max Capacity	100.0	100.0	105.0	99.0	360.0
MLP Limit (1-on-1)	65.0	65.0	65.0	65.0	35.0
MGBRT Limit	6	6	6	6	

Pseudo Unit Registration Data

Technical Data	Pseudo Facility				ST
	PSU1	PSU2	PSU3	PSU4	
ST Capacity Share	24.5%	25.5%	26.0%	24.0%	
Power Augmentation Capacity					120.0
MLP Limit (2-on-1)					70.0
MLP Limit (3-on-1)					105.0
MLP Limit (4-on-1)					140.0

Physical Unit Daily Generator Data

Resource Type	Physical Facility				
Technical Data	CT1	CT2	CT3	CT4	ST
MLP (1-on-1)	65.0	60.0	59.0	62.0	35.0
MLP (2-on-1)					70.0
MLP (3-on-1)					105.0
MLP (4-on-1)					140.0
MGBRT	6	6	6	6	
MGBDT	2	2	2	2	
Max Starts	1	1	1	1	
Single Cycle (Ignore ST Capacity)	1	1	1	1	

(0-Single Cycle, 1-Combined Cycle)

Pseudo Unit Calculated Parameters

Resource Type	Pseudo Facility			
Technical Data	PSU1	PSU2	PSU3	PSU4
Max Capacity	188.2000	191.8000	198.6000	185.4000
MLP (1-on-1)	100.0000	95.0000	94.0000	97.0000
MGBRT	6	6	6	6
MGBDT	2	2	2	2
Max Starts	1	1	1	1

Calculated Values -
 MP Entered Values -
 Not Required Values -
 Error -

Physical Registration -
 Pseudo Registration -
 Physical DGD -
 Pseudo DGD -
 Pseudo Sharing Data -

PSU Sharing Data

Resource Type	Pseudo Facility							
	PSU1		PSU2		PSU3		PSU4	
Technical Data	Operating Range	ST Share	Operating Range	ST Share	Operating Range	ST Share	Operating Range	ST Share
Minimum Loading Point Range	100.0	35.0%	95.0	36.8%	94.0	37.2%	97.0	36.0%
Dispatchable Range	58.8	40.4%	66.2	39.5%	73.4	37.3%	59.6	37.9%
Duct Firing Range	29.4	100.0%	30.6	100.0%	31.2	100.0%	28.8	100.0%

- EDAC results for PSU will be translated to physical CT and ST schedules and **committed** for use in real-time
 - Each CT in Schedule of Record will be constrained to the MLP submitted in the daily generation data
 - ST constraint will reflect scheduled PSU configuration in Schedule of Record, and will equal $MLP_{N-1, \dots}, MLP_{2-1}, MLP_{1-1}$

# of PSU's Scheduled	ST Committed to
1	MLP_{1-1}
2	MLP_{2-1}
...	...
N	MLP_{N-1}

- Constraint Schedules will be reported on physical units

Combined Cycle Facilities EDAC Commitments

- Resources at a Combined Cycle Facility that are scheduled in EDAC will be committed for use in real-time
 - Each CT in Schedule of Record will be constrained to the MLP submitted in the daily generation data
 - ST constraint will reflect scheduled CT configuration in Schedule of Record, and will equal $MLP_{N-1, \dots}, MLP_{2-1}, MLP_{1-1}$

# of CT's Scheduled	ST Committed to
1	MLP_{1-1}
2	MLP_{2-1}
...	...
N	MLP_{N-1}

- If the ST is not scheduled up to MLP_{N-1} it will receive a constraint to the next lowest MLP configuration that was scheduled

EDAC Dispatch Data

- Three Part Offers for dispatchable **not** quick start generators
 - Start-up cost
 - Speed-no-load cost
 - Incremental energy
- No changes to dispatch data for other resources:
 - Dispatchable Load
 - Dispatchable quick start generators
 - Non-dispatchable generators
 - Imports/exports

Start-up Cost

- The Start-Up Cost is a single value for each hour of the EDAC day. The data will be validated on submission based on the following validation rules:
 - Must not be a Quick Start generation unit
 - Number format xxxxxx.xx \$/start
 - Up to 24 quantities, one for each hour of the EDAC day
 - ≥ 0
 - Must be non-negative

Speed No-Load Cost

- The Speed-No Load Cost is a single value for each hour of the EDAC day. The data will be validated on submission based on the following validation rules:
 - Must be not be a Quick Start generation unit
 - Number format xxxxx.xx \$/hour
 - Up to 24 quantities, one for each hour of the EDAC day
 - ≥ 0
 - Must be non-negative

Incremental Energy Bids/Offers

- No change to existing bid/offer structure and validation
- Approved offers will be used by both EDAC and pre-dispatch (with the exception of pseudo-units)
- Incremental energy offers may be adjusted after the EDAC schedule of record is issued in accordance with existing submission window rules
- Pre-dispatch only considers incremental energy offers (ignores SNL & Start-up costs)
- Offers (for non-quick start generation units) may need to be changed after EDAC for hours where no EDAC schedule exists

- Price of MLP quantity can't be increased after the EDAC Schedule of Record
- MLP Price Cap – based on MLP price and quantity used to determine the EDAC Schedule of Record

*****Solution will be complex*****

- Requests for SMO on day 1 received before 9:00 will be approved/rejected by the EDAC Operator before 10:00
- Requests for SMO on day 1 received between 9:00 and 10:00 will be approved/rejected on an best-effort basis
- Requests for SMO on day 1 received after 10:00 will not be approved until 14:00 (may be rejected at any time)
- SMO requests must be for discrete days. Requests submitted Day 0 for Day 2 and beyond will be assessed by 9:00 day-ahead

Data Submission Prior to Optimization



- IESO issues 9 EST Day 1 System Status Report including (all items below are related to inputs for the EDAC Calculation Engine):
 - Ontario Demand Forecast
 - Ontario Supply Forecast
 - Operating Reserve Requirement
 - Ancillary Services
 - Transmission Interface Limitations
- Market Participants submit dispatch data and daily generation data (subject to data validation and approval rules) to be included in EDAC

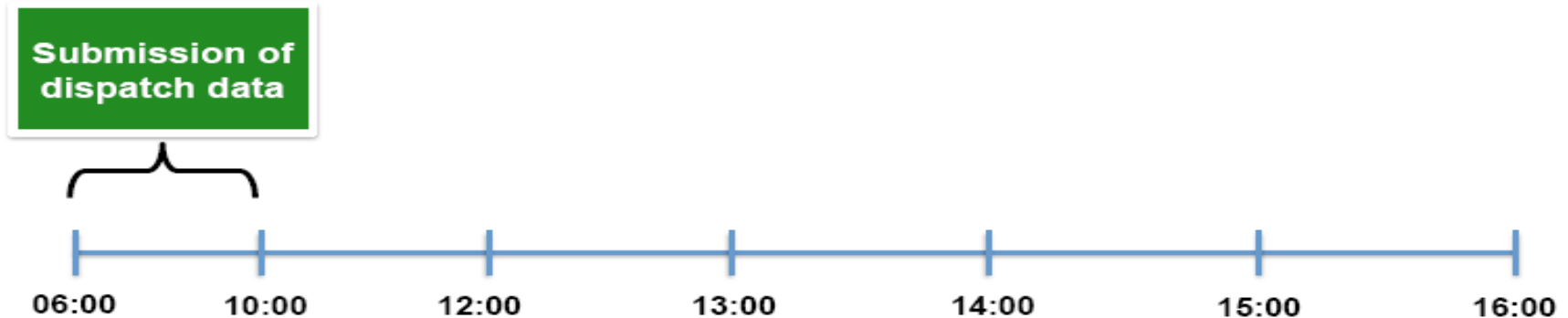

- Initial data submission window 06:00 -10:00 day ahead.
- Internal dispatchable resources must submit by 10:00 day ahead if they want to participate in real-time

EDAC Data Submission Timeline

EDAC - Data Submission Timeline

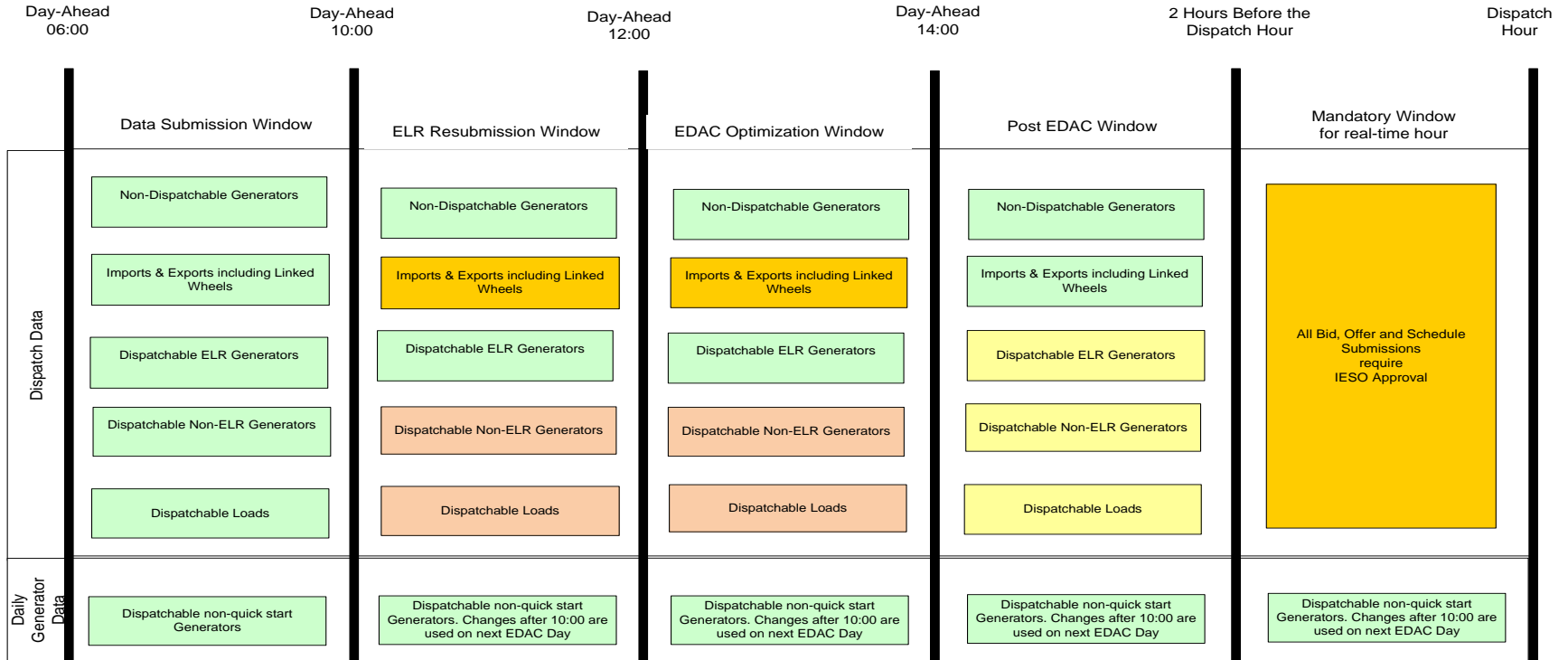

LEGEND

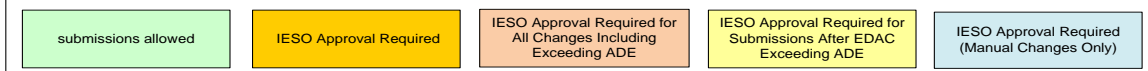

- A **not quick start** generator can submit three part energy offers
 - minimum loading point > 0 MW
 - minimum generation block run-time > 1 hour
 - ~~– Has a start up sequence > 1 hour in advance of the hour in which they first receive a schedule, so they can respond to dispatch instructions~~
- Dispatchable loads, imports, exports, and all other dispatchable generators continue to submit single part energy offers or bids

- For non-quick and not so quick start generation
- Daily Generator Data consists of
 - Minimum Loading Point
 - Minimum Generation Block Run Time
 - Minimum Generation Block Down Time
 - Maximum Number of Starts
 - Single Cycle Mode (CT Only) Flag
- Can be submitted daily, but will default to last set of values if no update provided

Linked Wheels



- The bid to export and offer to import associated with linked wheels will be scheduled based on economics
- The amount of energy scheduled for the export bid will be equal to the energy scheduled for the import offer

- An import and export are linked interchange schedules of the same wheeling through interchange schedule if:
 - the export is bid at +MMCP
 - the import is offered between -\$50 and –MMCP and
 - the associated NERC e-Tag IDs submitted by market participants along with their dispatch data have been edited to follow this formatting convention:
 - For import: **WI_SourceCA...SinkCA**
 - For export: **WX_SourceCA...SinkCA**

- Where:
 - “SourceCA...SinkCA” is the unique NERC e-Tag ID obtained from the NERC Tagging system for the wheeling interchange schedule.
 - WI is a delimiter indicating that the interchange schedule is the import leg of a wheel. The delimiter is added by the market participant to the NERC e-Tag ID submitted to the IESO as dispatch data for the import; and
 - WX is a delimiter indicating that the interchange schedule is the export leg of a wheel. The delimiter is added by the market participant to the NERC e-Tag

- Wheels are economically assessed against internal resources
- ~~Wheel respects transmission constraints~~
- Internal generation is ~~not constrained down for an economic~~ dispatched to respect transmission constraints with the linked wheel in place

EDAC Optimization Process



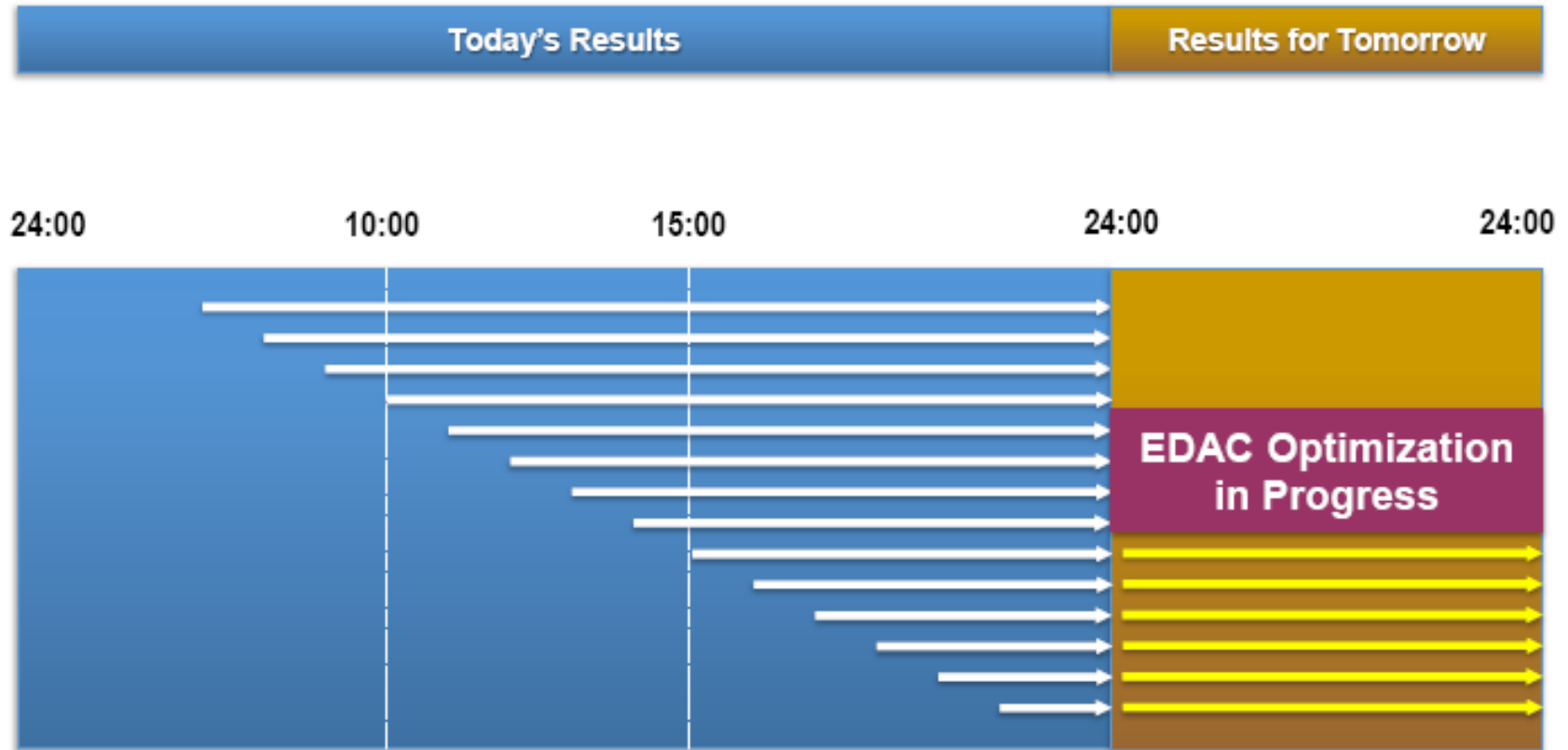

Pre-dispatch runs every hour; subsequent runs produce results that decrement by one hour

EDAC Commitment runs for tomorrow take place from 10:00 -15:00 at the same time pre-dispatch runs for the remainder of today are taking place

Pre-dispatch for tomorrow starts after 15:00 and includes EDAC outcomes

- Validating Inputs, Running the Calculation Engine and Verifying Results can all occur within a 1 hour timeframe.
- The number of EDAC runs that can be performed in a day is based on these assumptions.
- Depending on the actual runtime of the Calculation Engine, the following timeline may have to be revised.

Valid Results

- correct calculation indicating no problems
- correct calculation indicating a problem that the Market may be able to resolve

Invalid results

- correct calculation but based on incorrect inputs
- incorrect results because of a tool problem
- correct calculation but unacceptable results that the market cannot solve

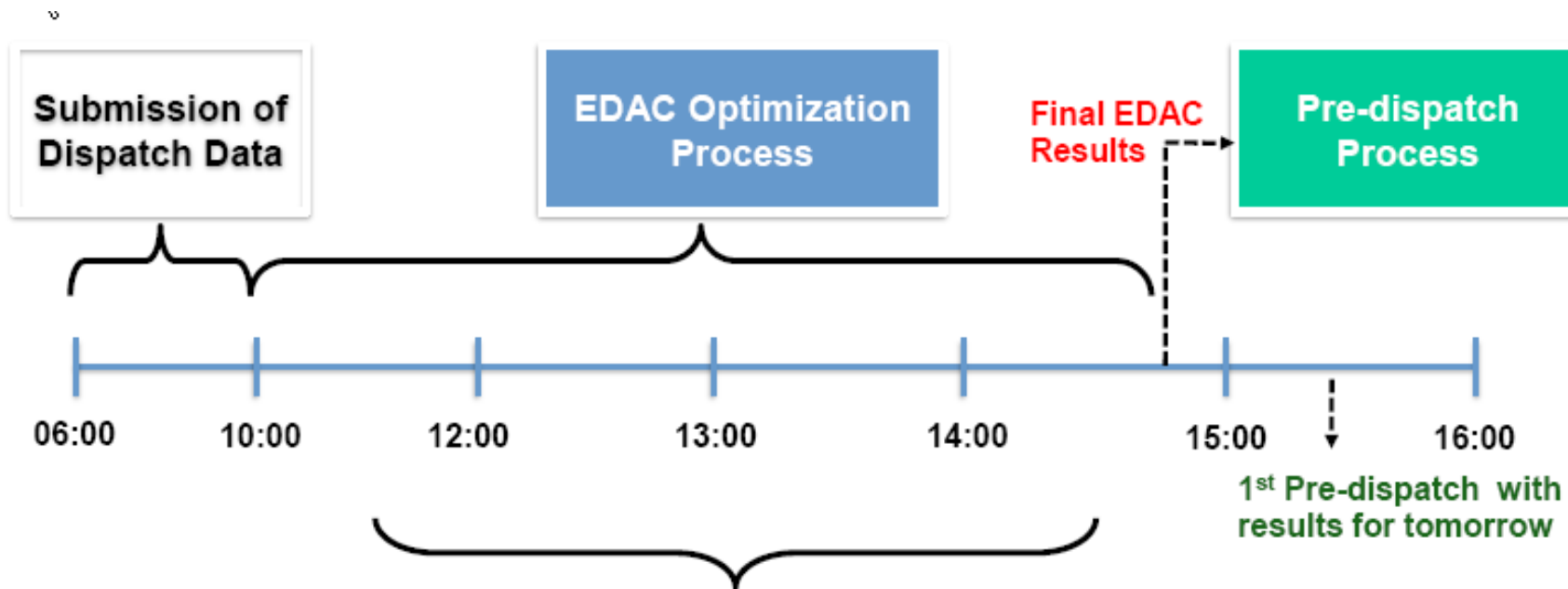

- Multiple runs
- Energy limited resources have one opportunity to resubmit data
- Pass 3 results published after each successful run

- Starts @ 10:00
- After run completes, EDAC operator validates results
 - Valid results are published, ELR Window opened at 11:00
 - Invalid results are not published. Initial run is declared a failure. Provided there is time, the initial run is rescheduled and the ELR window is delayed

Optimization Window For Eligible Energy Limited Resources (EELR) Open from 11:00 until 12:00

- Revised EELR Offers accepted
 - Must have offer with Daily Energy Limit in prior to 10:00
- Will also include:
 - Revised Non-dispatchable generation schedules/forecasts
 - Any recorded changes
 - Approved Dispatch Data ~~and Daily Generator Data~~

- After ELR Window closes
- ELR Optimization run start @ 12:00 EST
(provided that there was no delay from a failed initial run)
- EDAC Operator validates results:
 - Valid results are published
 - Invalid results are not published. ELR Optimization run is declared a failure and re-scheduled, time permitting

- capacity or energy shortfall
- generating unit change $\geq 400\text{MW}$
- operating security limit change $\geq 400\text{ MW}$
- intertie scheduling limit change $\geq 400\text{ MW}$
- ~~primary~~ demand forecast change $\geq 400\text{ MW}$
- reserve requirement change $\geq 400\text{ MW}$

In any hour of the EDAC Day (Day 1)

- Any subsequent run after the ELR Optimization run will be made if:
 - It is no later than 13:59 EST (to allow for validation and publishing before 15:00)
- AND**
- An EDAC Re-Run Criteria is met
- MPs will be notified that an ERC is met and when the subsequent run is scheduled for via an urgent Day 1 System Status Report
- Run is manually triggered by EDAC operator

- Calculation Engine does not initiate
- Calculation Engine starts but does not produce results
- Calculation Engine produces results that are invalid
- Results based on inputs that are no longer valid, due to material change, does **not** constitute failure

- The EDAC Schedule of Record is the most recent set of valid results published for the EDAC day
- If no valid results can be produced from the initial run (multiple attempts), then there is no EDAC Schedule of Record and EDAC is declared a failure that day

- Reports will be Published as ready
 - Normal completion time should be 13:00
- EDAC Schedule of Record will be Published no later than 15:00
 - Notification could be as early as 14:00
- Notification of EDAC Failure
 - If Results are not available or they cannot be published to the Market Participants
 - Market participants will be advised as soon as we know, but no later than 15:00

EDAC Possible Outcomes

10 EST	11 EST	12 EST	13 EST	14 EST	15 EST
Initial Run Valid	ELR Window Opens	ELR Optimization Run Valid	No Subsequent Run	No Subsequent Run	EDAC Successful
Initial Run Valid	ELR Window Opens	ELR Optimization Run Valid	Subsequent Run Valid	No Subsequent Run	EDAC Successful
Initial Run Valid	ELR Window Opens	ELR Optimization Run Valid	Subsequent Run Fails	No Subsequent Run	EDAC Successful
Initial Run Valid	ELR Window Opens	ELR Optimization Run Valid	No Subsequent Run	Subsequent Run Valid	EDAC Successful
Initial Run Fails	Initial Run Valid	ELR Window Opens	ELR Optimization Run Valid	No Subsequent Run	EDAC Successful
Initial Run Fails	Initial Run Valid	ELR Window Opens	ELR Optimization Run Valid	Subsequent Run Valid	EDAC Successful
Initial Run Fails	Initial Run Valid	ELR Window Opens	ELR Optimization Run Valid	Subsequent Run Fails	EDAC Successful
Initial Run Fails	Initial Run Fails	Initial Run Valid	ELR Window Opens	ELR Optimization Run Valid	EDAC Successful
Initial Run Fails	Initial Run Fails	Initial Run Fails	Initial Run Valid	No time for ELR Run, but Subsequent Run Possible	EDAC Successful
Initial Run Fails	Initial Run Fails	Initial Run Fails	Initial Run Fails	Initial Run Fails	EDAC Failure

Initialization Issues at Midnight for EDAC Calculation Engine



- The EDAC calculation engine will be initialized with the following variables:
 - Initial resource schedule
 - Initial hours of operations
 - Net interchange schedule
- The initialization will be based on the outcome of the most recent pre-dispatch DSO run for the day prior to EDAC day

- Determined only for dispatchable generators and loads
- Represents the dispatchable resource's initial schedule in HE24 of Day 0 (i.e., the last hour of the day) before the EDAC Day 1
 - if the dispatchable resource has a schedule different from zero or null in HE24 of Day 0 then the resource operation status shall be deemed to be **in operation** at the end of the day before the EDAC day

- Used by the engine to ensure the resource's hourly ramp rate is respected for the first hour of the EDAC Day 1, i.e., HE1
- Used to further determine the initial number of consecutive hours a dispatchable generator was in operation at the end of Day 0
- Pseudo-unit initial resource schedule will be determined based on the pre-dispatch schedule corresponding to the combustion turbine (CT) associated with the pseudo-unit

- Shall be determined only for dispatchable generators
- The pseudo-unit initial hours of operations will be determined based on the corresponding initial hours of operations of the combustion turbine (CT) associated with the pseudo-unit
- Represents the initial number of consecutive hours the dispatchable generator has a schedule greater than zero (i.e., in operation) at the end of Day 0 prior to the EDAC Day 1

- Process the resource's start up *offers* for generators at the beginning of the EDAC Day 1, i.e., HE1.
 - The engine will not consider the start-up *offers* for dispatchable generators that are already in operation in last hour of the day prior to the EDAC day (i.e., HE24 of Day 0) in determining the schedule for the first time point of the study (i.e., HE1 of EDAC Day 1)

- Satisfy the generator's MGBRT across midnight

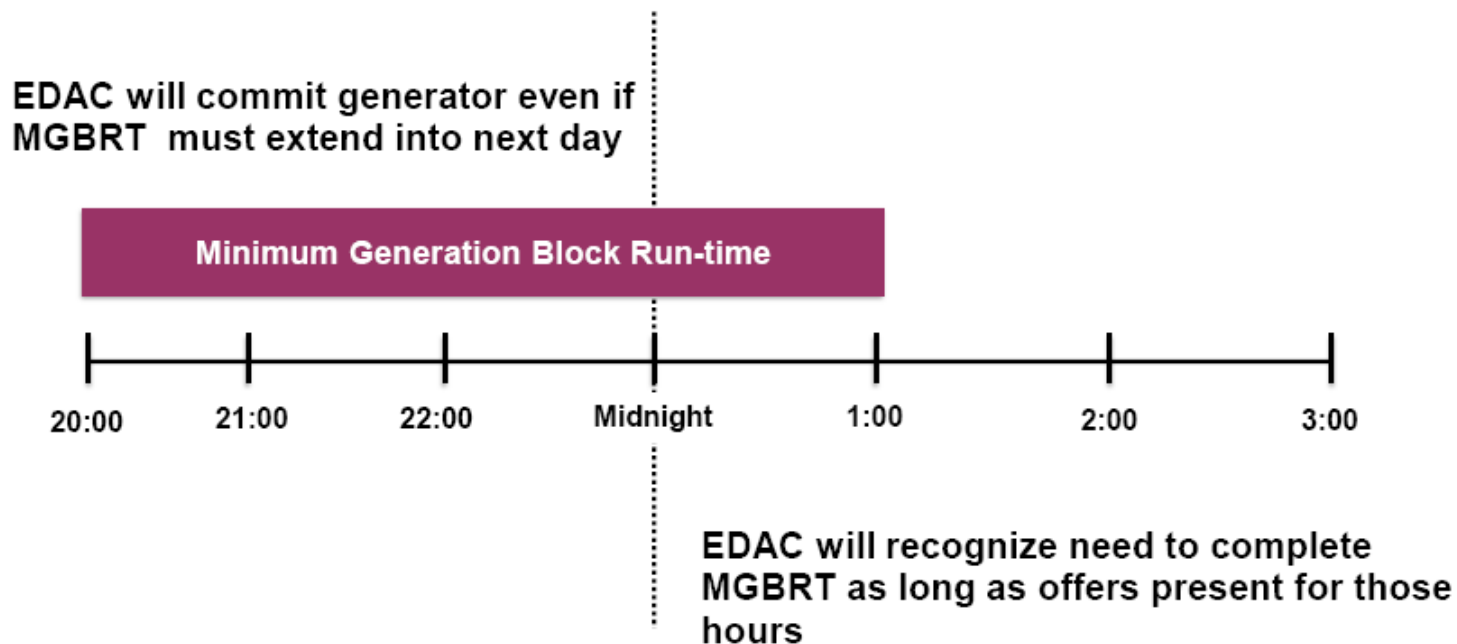

- A generator will have its MGBRT honoured across midnight **if it is:**
 1. **a** non-quick start generator; **and**
 2. **has** valid offers for all the hours required to satisfy its MGBRT in EDAC Day 1; **and**

The minimum of:

3. **in** operation in HE24 of Day 0 **for IHO hours** as determined by the most recent pre-dispatch DSO run for Day 0; **or**
4. **has** been constrained-on in HE24 of Day 0 **for IHO hours** as determined by the EDAC Day -1 run for Day 0

3. **IHO=Initial hours of Operation**

- Based on the initial hours in operation, the engine will commit the generator at the beginning of EDAC Day 1 for a minimum number of hours to satisfy its MGBRT
 - the most recent MLP and MGBRT (i.e., EDAC Day 1) daily generator data will be used to commit the generator at the beginning of EDAC day

- Generators may submit multi-part offers with escalating start-up costs at the end of the EDAC day in order to recover their start-up and minimum generation costs within that day

Start-up Offer and MGBRT Treatment at Midnight - Rationale

Case	EDAC Schedule HE24 in Day 0 (from EDAC Day -1 run) Generator Schedule	Contract Manager HE24 Day 0 (based on A & DA-PCG status) Generator Constrain-ON	Pre-Dispatch HE24 in Day 0 Generator Schedule	Generator Initial Hours of Operations (<i>IHO</i>) (based on B & C)	Consider Start-Up Offer For HE1 Day 1 (based on D)	Satisfy MGBRT Across Midnight (based on B & D)
	A	B	C	D	E	F
	$\neq 0$ = in operation 0 = not in operation	YES = constrain-ON in CM NO = no constraint in CM	$\neq 0$ = in operation 0 = not in operation	> 0 = in operation 0 = not in operation	YES = start-up offer is considered NO = start-up offer is not considered	YES = MGBRT is satisfied NO = MGBRT is not satisfied
1	$\neq 0$	YES	$\neq 0$	$0 < iho \leq 24$	NO	YES
2	$\neq 0$	NO	$\neq 0$	24	NO	NO
3	0	NO	$\neq 0$	24	NO	NO
4	$\neq 0$	YES	0	0	YES	NO
5	$\neq 0$	NO	0	0	YES	NO
6	0	NO	0	0	YES	NO
	Information	Input Data		Calculated Value	Treatment by EDAC Calculation Engine	

- Represents the Day 0, HE24 net schedule value of all Imports and Exports of synchronous interties
 - A single value, reported in MW

- EDAC respects all minimum down times within the day, but is not initialized with the remaining hours a generator needs over midnight to respect its minimum down time
- It is up to the generator to offer in a manner to ensure that minimum down time is respected over midnight

EDAC Calculation Engine



- Performs two functions, commitment and scheduling.
- The final output is:
 - Schedules for all committed resources (non-quick start generators and imports), quick start facilities, dispatchable loads and exports, to meet average forecast demand.
- Co-optimizes energy and operating reserve over 24 hours of the next day
- Uses three passes each time it runs to determine the final set of day-ahead commitments and schedules

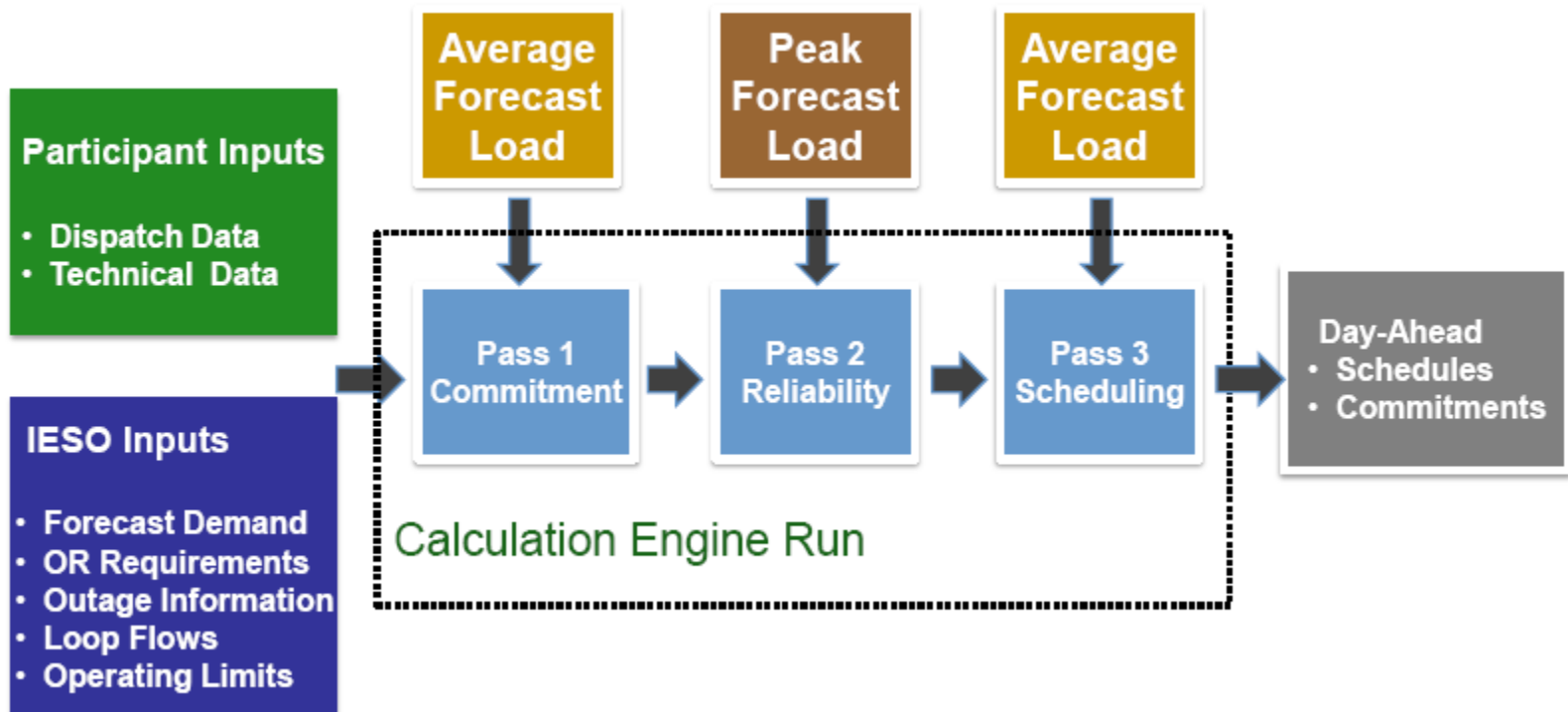

- Minimizes total costs to serve average demand for the next day
- Average rather than peak is used to prevent over-commitment

- Minimizes any additional commitment costs to meet peak demand, which normally occurs for one interval
- Options:
 - Ramp up quick start or already committed non-quick start generator
 - Ramp down dispatchable load
 - Schedule **an** import (must reduce generation in other intervals)
 - Reduce an export (must reduce generation in other intervals)
 - Commit an additional non-quick start generator

- Offers from non-quick starts committed in Pass 1 and all offers from quick starts that are greater than their shadow prices in Pass 1 are evaluated:
- This averages out the cost per interval
- Bids for dispatchable loads are treated similarly

- Schedule the remaining capacity above the minimum loading point of non-quick start generators committed in Pass 1
- Schedule quick start generators
- Imports committed in Pass 1 cannot be scheduled lower than their Pass 1 amounts
- Exports and dispatchable loads can be reduced from their Pass 1 amounts

- Least cost, security constrained scheduling to meet average demand and operating reserve requirements for each hour of the next day
- Produces the final day-ahead constrained schedules used for the determination of day-ahead guarantees for committed imports and non-quick starts

- Committed non-quick starts from Passes 1 and 2 are scheduled to at least their minimums
- Committed imports are scheduled to at least their schedules in Pass 2
- Exports ~~and dispatchable loads~~ are scheduled to no greater than their Pass 2 schedules
- Considers the energy from non-quick starts ramping up to their minimum loading points when determining the schedules for all resources

Data Submission While Optimization is in Progress



EDAC Data Submission Timeline

EDAC - Data Submission Timeline

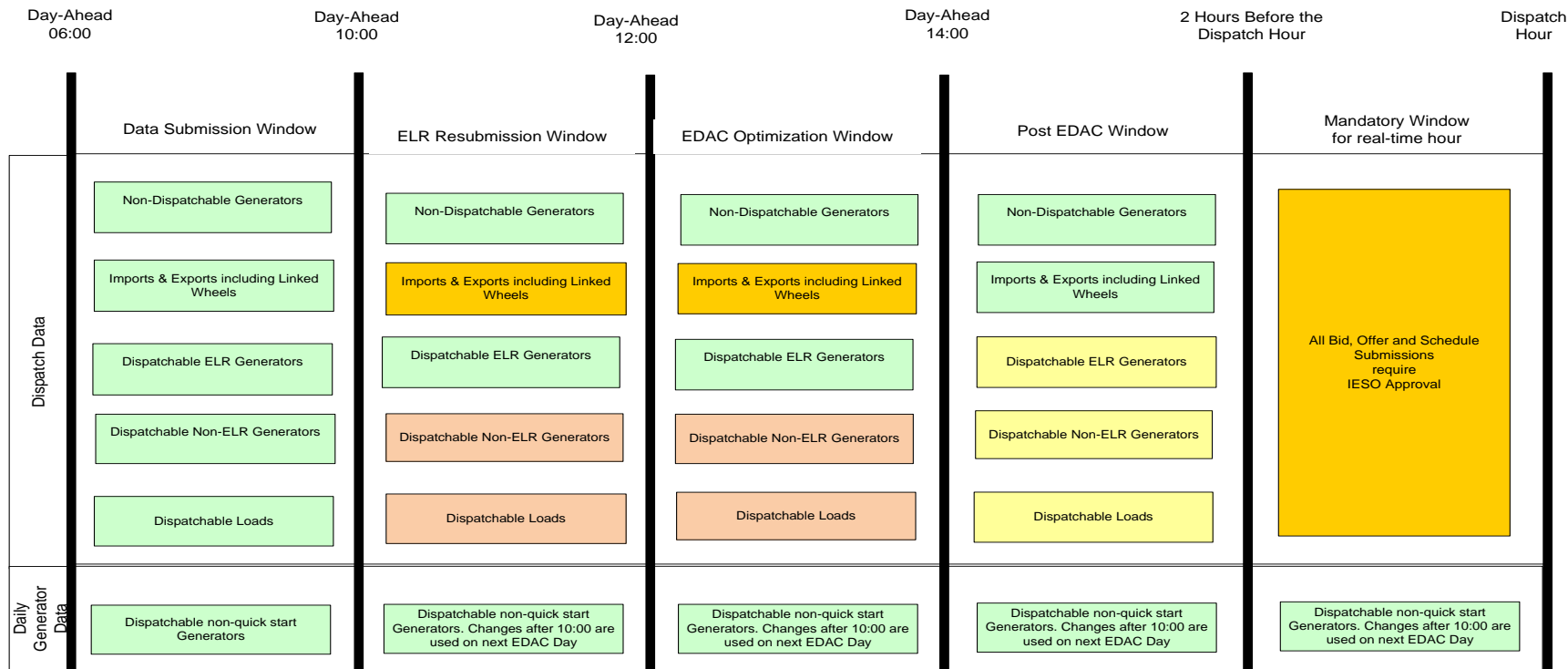

LEGEND

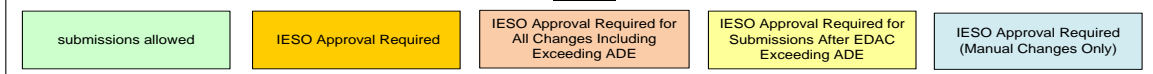

- The first run of EDAC is initiated at 10:00.
- From 11:00 to 12:00 no restrictions will apply to *Dispatch Data* changes from Eligible Energy Limited Resources (all new submissions, revisions, and cancellation requests) applicable for any hours of the next day which submitted energy offers before 10:00
- From 10:00 to 14:00, Dispatch Data changes from Dispatchable Generators and Dispatchable Loads (all new submissions, revisions, and cancellation requests) applicable for any hours of the next day will require operator approval

- Dispatch Data submissions from Dispatchable Generators or Dispatchable Loads which are subject to operator approval must be accompanied by one of the currently defined reason codes. If “OTHER” is selected, a corresponding text description must be included. If a reason code is not included, the bid/offer will be automatically rejected with a validation error issued
- Dispatch Data for Dispatchable Generators or Dispatchable Loads waiting for operator approval at 14:00, will be automatically rejected
 - Any dispatch data from other resources waiting for operator approval at 14:00, will be automatically accepted (subject to validation)
- ~~All changes to Daily Generator Data are automatically approved and flagged to Compliance used on the next~~ **EDAC Day** ¹¹³

Reporting and Notification



- Other than the deletion of the 10:30 SSR, the timing and the content of SSRs will remain the same as current
- Prior to closure of the EDAC bid/offer window, the 9 EST system status report detailing the operating state of the IESO-controlled grid is published to aid market participants in making market and operational decisions
- Day 1 SSR will also be used to convey EDAC notifications

- A summary of projected shortfall/surplus of energy based on offers for the next day
- Information Included
 - Demand, OR Requirement, Energy Scheduled by East and West Zone
 - Imports – by Intertie Zone
 - Scheduled exports and average forecast demand will be included as above
 - Aggregate import/export bids and offers by intertie zone

DACP Adequacy

Created at May 12, 2009 14:18:42
For May 13, 2009

Ontario			Hour																							
			1	2	3	4	5	6	7	8	9	10	11	12	13	14	15	16	17	18	19	20	21	22	23	24
Ontario Demand			12189	11985	11850	12157	12919	14332	15603	16139	16341	16544	16734	16749	16833	16613	16519	16436	16429	16288	16180	16344	16150	15390	14034	12865
OR Requirements			1400	1400	1400	1400	1400	1400	1400	1400	1400	1400	1400	1400	1480	1480	1480	1480	1480	1480	1480	1480	1480	1480	1480	1480
Total Requirement			13589	13385	13250	13557	14319	15732	17003	17539	17741	17944	18134	18149	18313	18093	17999	17916	17909	17768	17660	17824	17630	16870	15514	14345
Internal Resources	Internal Generation	Offered	22595	22595	22595	22595	22595	22643	22705	22734	22735	22735	22735	22732	22710	22710	22710	22755	22755	22755	22755	22755	22755	22644	22638	
		Scheduled	11985	11781	11646	11953	12559	14127	15284	15643	16117	15937	16223	16342	16284	16345	16352	16266	15868	16270	16196	16364	16163	15352	13830	12661
	Dispatchable Loads	Bid	-391	-391	-391	-391	-391	-381	-331	-331	-332	-331	-331	-331	-331	-331	-331	-331	-331	-321	-391	-391	-297	-297	-297	
		Scheduled	-391	-391	-391	-391	-391	-381	-331	-331	-332	-331	-331	-331	-331	-331	-331	-331	-331	-321	-391	-391	-297	-297	-297	
	Total	Offered/Bid	22986	22986	22986	22986	22986	23024	23036	23065	23067	23066	23066	23086	23063	23041	23041	23041	23086	23076	23146	23146	23052	23052	22941	22935
		Scheduled	12376	12172	12037	12344	12950	14508	15615	15974	16449	16268	16554	16673	16615	16676	16683	16597	16199	16591	16587	16755	16460	15649	14127	12958
Scheduled Imports	Manitoba	0	0	0	0	0	0	0	0	0	0	0	0	0	0	0	0	0	0	0	0	0	0	0	0	
	Minnesota	40	40	40	40	40	40	2	32	0	40	0	28	40	40	40	40	40	36	0	1	0	40	40	40	
	Michigan	0	0	0	0	155	0	0	0	0	50	0	0	0	0	0	0	0	0	0	0	0	0	0	0	
	New York	0	0	0	0	0	0	0	0	0	0	0	0	0	0	0	0	0	0	0	0	0	0	0	0	
	Quebec	0	0	0	0	0	0	152	318	243	541	541	409	541	254	152	152	541	0	0	0	0	0	0	0	
	Total	40	40	40	40	195	40	154	350	243	631	541	437	581	294	192	192	581	36	0	1	0	40	40	40	
Capacity Excess/Shortfall			9841	10045	10180	9873	9111	7737	7019	6512	6311	6108	5918	5923	5736	5934	6028	6111	6163	6417	6472	6308	6408	7291	7995	9035
Resources Not Scheduled			11001	11205	11340	11033	10426	8897	7752	7422	6949	7128	6843	6744	6779	6696	6690	6775	7217	6807	6950	6782	6889	7702	9112	10275
Supply Cushion %			72.4	75.0	76.8	72.8	63.6	49.2	41.3	37.1	35.6	34.0	32.6	32.6	31.3	32.8	33.5	34.1	34.4	36.1	36.6	35.4	36.3	43.2	51.5	63.0

East			Hour																							
			1	2	3	4	5	6	7	8	9	10	11	12	13	14	15	16	17	18	19	20	21	22	23	24
Demand			11725	11535	11402	11713	12452	13833	15072	15598	15893	16088	16265	16273	16353	16090	15961	15896	15867	15730	15624	15783	15582	14828	13492	12345
	Internal Generation	Offered	21605	21605	21605	21605	21605	21653	21715	21745	21745	21745	21745	21765	21742	21720	21720	21765	21765	21765	21765	21765	21765	21654	21648	
		Scheduled	11376	11188	11053	11360	11966	13534	14648	15007	15481	15301	15587	15735	15701	15762	15769	15654	15256	15634	15560	15728	15514	14716	13251	12131

- Report contains Shadow Prices at selected nodes within Ontario.
- Information Included
 - Shadow Price
 - Node
 - Shadow Price Type - Energy, 10S, 10N, 30R

Nodes	Type	Shadow Price for Hour...																							
		1	2	3	4	5	6	7	8	9	10	11	12	13	14	15	16	17	18	19	20	21	22	23	24
ABITIBIMN-LT.TT_LF	Energy	3.94	26.85	29.07	29.06	32.70	34.73	33.59	33.57	8.87	21.28	5.22	13.09	8.17	15.40	10.42	10.42	5.21	8.17	5.21	8.17	22.84	39.91	29.55	32.40
	10S	21.85	0.01	40.36	0.01	0.01	0.01	0.00	39.23	0.00	0.00	0.00	0.00	0.00	0.00	0.00	0.00	0.00	0.00	0.00	0.01	0.01	0.01	0.00	0.00
	10N	21.85	0.01	40.36	0.01	0.01	0.01	0.00	39.23	0.00	0.00	0.00	0.00	0.00	0.00	0.00	0.00	0.00	0.00	0.00	0.01	0.01	0.01	0.00	0.00
	30R	4.89	-16.95	4.90	-64.63	-72.70	-29.51	-69.82	7.79	-83.32	-587.61	-149.91	-159.00	-289.80	-244.28	-584.23	-591.21	-310.52	-271.51	-592.00	-599.52	-569.79	-181.40	-314.60	-79.63
ABKENORA-LT.AG	Energy	-39.58	-12.06	-12.19	-12.19	-12.40	-12.51	-12.45	6.43	7.82	7.56	4.99	7.82	7.82	7.82	7.82	7.82	4.99	7.82	4.99	7.82	7.82	10.78	6.71	6.47
	10S	21.85	21.85	40.36	69.54	77.61	34.42	77.61	39.23	104.52	601.23	165.51	171.77	302.58	257.06	597.00	603.22	322.53	283.52	604.01	612.31	582.58	194.18	319.51	84.54
	10N	21.85	21.85	40.36	69.54	77.61	34.42	77.61	39.23	104.52	601.23	165.51	171.77	302.58	257.06	597.00	603.22	322.53	283.52	604.01	612.31	582.58	194.18	319.51	84.54
	30R	4.89	4.89	4.90	4.90	4.90	4.90	7.79	7.79	21.20	13.61	15.60	12.77	12.78	12.78	12.77	12.01	12.01	12.01	12.01	12.78	12.78	12.77	4.90	4.90
AGUASABON-LT.AG12	Energy	3.68	25.26	27.35	27.35	30.78	32.68	31.61	31.61	8.36	20.05	4.91	12.33	7.69	14.51	9.82	9.82	4.91	7.69	4.91	7.69	21.52	37.59	27.83	30.50
	10S	21.85	0.01	40.36	0.01	0.01	0.01	0.00	39.23	0.00	0.00	0.00	0.00	0.00	0.00	0.00	0.00	0.00	0.00	0.00	0.01	0.01	0.01	0.00	0.00
	10N	21.85	0.01	40.36	0.01	0.01	0.01	0.00	39.23	0.00	0.00	0.00	0.00	0.00	0.00	0.00	0.00	0.00	0.00	0.00	0.01	0.01	0.01	0.00	0.00
	30R	4.89	-16.95	4.90	-64.63	-72.70	-29.51	-69.82	7.79	-83.32	-587.61	-149.91	-159.00	-289.80	-244.28	-584.23	-591.21	-310.52	-271.51	-592.00	-599.52	-569.79	-181.40	-314.60	-79.63
ALEXANDER-LT.AG_T1	Energy	3.62	24.85	26.91	26.91	30.28	32.15	31.09	31.09	8.22	19.72	4.83	12.13	7.57	14.27	9.66	9.66	4.83	7.57	4.83	7.57	21.17	36.98	27.38	30.01
	10S	21.85	0.01	40.36	0.01	0.01	0.01	0.00	39.23	0.00	0.00	0.00	0.00	0.00	0.00	0.00	0.00	0.00	0.00	0.00	0.01	0.01	0.01	0.00	0.00
	10N	21.85	0.01	40.36	0.01	0.01	0.01	0.00	39.23	0.00	0.00	0.00	0.00	0.00	0.00	0.00	0.00	0.00	0.00	0.00	0.01	0.01	0.01	0.00	0.00
	30R	4.89	-16.95	4.90	-64.63	-72.70	-29.51	-69.82	7.79	-83.32	-587.61	-149.91	-159.00	-289.80	-244.28	-584.23	-591.21	-310.52	-271.51	-592.00	-599.52	-569.79	-181.40	-314.60	-79.63

- Provides Operating Reserve shortfalls in each hour for an EDAC day, by dispatch areas.
- Information Included:
 - Dispatch Area Total Requirement
 - 10S Scheduled
 - 10N Scheduled
 - OR Shortfall

Predispatch Area Operating Reserve Shortfalls

[Help](#)

Created at May 19, 2009 10:10:10
For May 19, 2009

Area	Quantity	MW for Hour																							
		1	2	3	4	5	6	7	8	9	10	11	12	13	14	15	16	17	18	19	20	21	22	23	24
Area Total	Total Required	0	0	0	0	0	0	0	0	0	0	0	0	0	0	0	0	0	0	0	0	0	0	0	0
	Total Scheduled 10S	1612	1385	1385	1499	832	1193	1360	1597	1796	1863	1905	1998	1965	2004	2004	1918	1951	1951	1951	2149	2149	2149	1948	1386
	Total Scheduled 10N	2909	3304	3259	2684	2996	2310	2181	1901	1651	1582	1463	1300	1323	1284	1284	1448	1415	1415	1414	1153	1153	1153	1811	2551
	Total Shortfall	0	0	0	0	0	0	0	0	0	0	0	0	0	0	0	0	0	0	0	0	0	0	0	0
ALLANBURG	Min. Required	0	0	0	0	0	0	0	0	0	0	0	0	0	0	0	0	0	0	0	0	0	0	0	
	Scheduled 10S	0	0	0	2	2	30	87	96	105	149	108	40	31	40	40	77	86	86	86	130	130	130	128	15
	Scheduled 10N	98	127	127	127	199	103	103	104	85	131	88	12	2	12	12	53	63	63	63	185	185	185	114	233
	Shortfall	0	0	0	0	0	0	0	0	0	0	0	0	0	0	0	0	0	0	0	0	0	0	0	0
BRUCEB	Min. Required	0	0	0	0	0	0	0	0	0	0	0	0	0	0	0	0	0	0	0	0	0	0	0	
	Scheduled 10S	0	0	0	0	0	0	0	0	0	0	0	0	0	0	0	0	0	0	0	0	0	0	0	0
	Scheduled 10N	12	12	12	12	12	12	12	12	12	12	12	12	12	12	12	12	12	12	12	12	12	12	12	12
	Shortfall	0	0	0	0	0	0	0	0	0	0	0	0	0	0	0	0	0	0	0	0	0	0	0	0

- Contains the internal Operating Reserve Constraints produced by the EDAC Calculation Engine for each hour of the EDAC day
- Information Included:
 - Region
 - Operating Reserve Type 10S, 10N and/or 30R
 - Constrained MW

Predispatch Area Reserve Constraints Report

[Help](#)

Created at May 19, 2009 10:10:14
For May 19, 2009

Region	Type	Constrained MW for Hour																							
		1	2	3	4	5	6	7	8	9	10	11	12	13	14	15	16	17	18	19	20	21	22	23	24
ALLANBURG	10S	0	0	0	0	0	0	0	0	0	0	0	0	0	0	0	0	0	0	0	0	0	0	0	0
ALLANBURGN	10N	0	0	0	0	0	0	0	0	0	0	0	0	0	0	0	0	0	0	0	0	0	0	0	0
	30R	0	0	0	0	0	0	0	0	0	0	0	0	0	0	0	0	0	0	0	0	0	0	0	0
ALLANBURGX	10N	9999	9999	9999	9999	9999	9999	9999	9999	9999	9999	9999	9999	9999	9999	9999	9999	9999	9999	9999	9999	9999	9999	9999	9999
BRUCEA	10S	0	0	0	0	0	0	0	0	0	0	0	0	0	0	0	0	0	0	0	0	0	0	0	0
BRUCEAN	10N	0	0	0	0	0	0	0	0	0	0	0	0	0	0	0	0	0	0	0	0	0	0	0	0
	30R	0	0	0	0	0	0	0	0	0	0	0	0	0	0	0	0	0	0	0	0	0	0	0	0
BRUCEAX	10N	9999	9999	9999	9999	9999	9999	9999	9999	9999	9999	9999	9999	9999	9999	9999	9999	9999	9999	9999	9999	9999	9999	9999	9999
BRUCEB	10S	0	0	0	0	0	0	0	0	0	0	0	0	0	0	0	0	0	0	0	0	0	0	0	0
BRUCEBN	10N	0	0	0	0	0	0	0	0	0	0	0	0	0	0	0	0	0	0	0	0	0	0	0	0
	30R	0	0	0	0	0	0	0	0	0	0	0	0	0	0	0	0	0	0	0	0	0	0	0	0
BRUCEBX	10N	9999	9999	9999	9999	9999	9999	9999	9999	9999	9999	9999	9999	9999	9999	9999	9999	9999	9999	9999	9999	9999	9999	9999	9999
CANYON115	10S	0	0	0	0	0	0	0	0	0	0	0	0	0	0	0	0	0	0	0	0	0	0	0	0
CANYON115N	10N	0	0	0	0	0	0	0	0	0	0	0	0	0	0	0	0	0	0	0	0	0	0	0	0
	30R	0	0	0	0	0	0	0	0	0	0	0	0	0	0	0	0	0	0	0	0	0	0	0	0
CANYON115X	10N	9999	9999	9999	9999	9999	9999	9999	9999	9999	9999	9999	9999	9999	9999	9999	9999	9999	9999	9999	9999	9999	9999	9999	9999

- Provides a forecast of expected load, available energy, OR requirements and losses for each hour of the EDAC constrained schedule
- Information Included:
 - Total Energy
 - Total Dispatchable Load
 - Total Load
 - Total Loss
 - Total 10N, 10S, 30R

Predispatch Constrained Totals Report

[Help](#)

Created at May 19, 2009 10:10:08
For May 19, 2009

Hour	MW						
	TOTAL ENERGY	TOTAL LOSS	TOTAL LOAD	TOTAL DISP LOAD	TOTAL 10S	TOTAL 10N	TOTAL 30R
1	13310.1	435.6	12874.4	204.8	400.2	579.8	540.0
2	13382.1	466.5	12915.6	169.0	343.5	636.5	540.0
3	13264.9	469.9	12795.0	168.8	343.5	636.5	540.0
4	13641.0	467.9	13173.0	168.8	389.7	590.3	540.0
5	14273.3	492.5	13780.8	211.7	264.6	715.4	540.0
6	15436.9	535.4	14901.5	0.0	378.6	601.4	540.0
7	16738.8	589.2	16149.6	0.0	415.1	564.9	540.0
8	17176.7	612.1	16564.6	0.0	479.2	500.9	540.0
9	17459.1	647.4	16811.7	0.0	529.5	450.5	540.0
10	17194.7	649.4	16545.3	0.0	546.4	433.6	540.0
11	17345.7	642.5	16703.2	0.0	576.2	403.8	540.0
12	17196.6	643.9	16552.7	0.0	617.0	363.0	540.0
13	17379.5	642.7	16736.8	0.0	610.1	369.9	540.0
14	17184.0	628.5	16555.5	0.0	619.9	360.1	540.0
15	16936.0	628.0	16308.0	0.0	619.9	360.1	540.0
16	16762.9	623.8	16139.1	0.0	578.9	401.1	540.0
17	16772.1	615.7	16156.4	0.0	587.2	392.8	540.0
18	16525.5	608.4	15917.1	0.0	587.2	392.8	540.0
19	16368.1	600.4	15767.8	0.0	587.2	392.8	540.0
20	16482.6	605.7	15876.9	0.0	652.6	327.4	540.0

- The intertie scheduling limits used as inputs to the EDAC calculation engine
- Information Included:
 - Intertie Zone
 - Scheduling Limit

Predispach Intertie Scheduling Limits Report

[Help](#)

Created at May 19, 2009 10:09:47
For May 19, 2009

Hour	EnergyMW																											
	Manitoba		Michigan		Minnesota		New York		Quebec B5D-B31L		Quebec D5A		Quebec D4Z		Quebec H9A		Quebec H4Z		Quebec P33C		Quebec Q4C		Quebec X2Y		Manitoba SK1			
	to	from	to	from	to	from	to	from	to	from	to	from	to	from	to	from	to	from	to	from	to	from	to	from	to	from		
1	-25	225	-2270	1180	-140	65	-1000	1200	0	390	-190	240	0	0	0	0	-85	0	0	335	0	0	0	65	0	50		
2	-25	225	-2270	1180	-140	65	-1000	1200	0	390	-190	240	0	0	0	0	-85	0	0	335	0	0	0	65	0	50		
3	-25	225	-2270	1180	-140	65	-1000	1200	0	390	-190	240	0	0	0	0	-85	0	0	335	0	0	0	65	0	50		
4	-25	225	-2270	1180	-140	65	-1000	1200	0	390	-190	240	0	0	0	0	-85	0	0	335	0	0	0	65	0	50		
5	-25	225	-2270	1180	-140	65	-1000	1200	0	390	-190	240	0	0	0	0	-85	0	0	335	0	0	0	65	0	50		
6	-25	225	-2270	1180	-140	65	-1000	1200	0	390	-190	240	0	0	0	0	-85	0	0	335	0	0	0	65	0	50		
7	-25	225	-1870	1580	-140	65	-1400	1110	0	790	-190	240	0	0	0	0	-85	0	0	335	0	0	0	65	0	50		
8	-25	225	-1870	1580	-140	65	-1400	1110	0	790	-190	240	0	0	0	0	-85	0	0	335	0	0	0	65	0	50		
9	-25	225	-1870	1580	-140	65	-1400	1110	0	790	-190	240	0	0	0	0	-85	0	0	335	0	0	0	65	0	50		
10	-25	225	-1870	1580	-140	65	-1400	1110	0	790	-190	240	0	0	0	0	-85	0	0	335	0	0	0	65	0	50		
11	-25	225	-1870	1580	-140	65	-1400	1110	0	790	-190	240	0	0	0	0	-85	0	0	335	0	0	0	65	0	50		
12	-25	225	-1870	1580	-140	65	-1400	1110	0	790	-190	240	0	0	0	0	-85	0	0	335	0	0	0	65	0	50		
13	-25	225	-1870	1580	-140	65	-1400	1110	0	790	-190	240	0	0	0	0	-85	0	0	335	0	0	0	65	0	50		
14	-25	225	-1870	1580	-140	65	-1400	1110	0	790	-190	240	0	0	0	0	-85	0	0	335	0	0	0	65	0	50		
15	-25	225	-1870	1580	-140	65	-1400	1110	0	790	-190	240	0	0	0	0	-85	0	0	335	0	0	0	65	0	50		

- A list of binding security constraints for the EDAC run



Created at May 19, 2009 10:10:10
For May 19, 2009

Hour	Constraint	
1	BASE CASE	0 CR-LIM.NE.MaxFS
1	BASE CASE	0 CR-LIM.NW.MaxEWTE
1	BASE CASE	0 CR-LIM.NW.MaxMissEcctE
1	BASE CASE	0 H9K.KAXCA
1	BASE CASE	0 H9K.TEXFA
1	BASE CASE	0 NANT.UNIT.TOTAL-G1G4.EQ03(G1~0
1	BASE CASE	0 NE-FNFS.S.ALLI/S.2
1	BASE CASE	0 NW.T1.EWTEm
1	BASE CASE	0 NW.T1.MEE1
1	BASE CASE	0 NW.T1.NW4
1	BASE CASE	0 NW.T1.NW6
1	BASE CASE	0 NW.T17.EWTEm
1	BASE CASE	0 NW.T17.MEE1
1	BASE CASE	0 NW.T5A.EWTEm
1	BASE CASE	0 NW.T5A.MEE1
1	BASE CASE	0 NW115T.K23D_O/S_30C.K3D_E1
1	BASE CASE	0 S-CLAN-CLAS.ALL(I/S).EQ2-S
1	P13T_SCT	1 H7T.HUXWA
1	S4S_SCT	1 H9K.KAXCA

- Provides the MP with confirmation of their dispatch data submissions used for EDAC and ADE
- Information Included:
 - MP Resource, NERC Tag (if required), Energy PQ pairs, DEL, Hours 1-24

DACP Check Source / ADE

[Help](#)

For Market Participant #1
Created at Jan 06, 2009 14:15:22
For Jan 07, 2009

Resource ID	NERC Tag ID (if applicable)	Hour	Energy (PQ Pairs)	Daily Energy Limit (if applicable)
GENERATOR.G1		1	{5.00,0.0}{5.00,10.0}{13.00,47.0}{15.00,17.0}{20.00,20.0}	448
		2	{5.00,0.0}{5.00,10.0}{13.00,47.0}{15.00,17.0}{20.00,20.0}	
		3	{5.00,0.0}{5.00,10.0}{13.00,47.0}{15.00,17.0}{20.00,20.0}	
		4	{5.00,0.0}{5.00,10.0}{13.00,47.0}{15.00,17.0}{20.00,20.0}	
		5	{5.00,0.0}{5.00,10.0}{13.00,47.0}{15.00,17.0}{20.00,20.0}	
		6	{5.00,0.0}{5.00,10.0}{13.00,47.0}{15.00,17.0}{20.00,20.0}	
		7	{5.00,0.0}{5.00,10.0}{13.00,47.0}{15.00,17.0}{20.00,20.0}	
		8	{5.00,0.0}{5.00,10.0}{13.00,47.0}{15.00,17.0}{20.00,20.0}	
		9	{5.00,0.0}{5.00,10.0}{13.00,47.0}{15.00,17.0}{20.00,20.0}	
		10	{5.00,0.0}{5.00,10.0}{13.00,47.0}{15.00,17.0}{20.00,20.0}	
		11	{5.00,0.0}{5.00,10.0}{13.00,47.0}{15.00,17.0}{20.00,20.0}	
		12	{5.00,0.0}{5.00,10.0}{13.00,47.0}{15.00,17.0}{20.00,20.0}	
		13	{5.00,0.0}{5.00,10.0}{13.00,47.0}{15.00,17.0}{20.00,20.0}	
		14	{5.00,0.0}{5.00,10.0}{13.00,47.0}{15.00,17.0}{20.00,20.0}	
		15	{5.00,0.0}{5.00,10.0}{13.00,47.0}{15.00,17.0}{20.00,20.0}	
		16	{5.00,0.0}{5.00,10.0}{13.00,47.0}{15.00,17.0}{20.00,20.0}	
		17	{5.00,0.0}{5.00,10.0}{13.00,47.0}{15.00,17.0}{20.00,20.0}	
		18	{5.00,0.0}{5.00,10.0}{13.00,47.0}{15.00,17.0}{20.00,20.0}	
		19	{5.00,0.0}{5.00,10.0}{13.00,47.0}{15.00,17.0}{20.00,20.0}	
		20	{5.00,0.0}{5.00,10.0}{13.00,47.0}{15.00,17.0}{20.00,20.0}	
		21	{5.00,0.0}{5.00,10.0}{13.00,47.0}{15.00,17.0}{20.00,20.0}	
		22	{5.00,0.0}{5.00,10.0}{13.00,47.0}{15.00,17.0}{20.00,20.0}	
		23	{5.00,0.0}{5.00,10.0}{13.00,47.0}{15.00,17.0}{20.00,20.0}	
		24	{5.00,0.0}{5.00,10.0}{13.00,47.0}{15.00,17.0}{20.00,20.0}	

- Provides energy schedules for each hour of the next day
- Information Included
 - MP Resource, Constrained, NERC tag, Hours 1-24

DACP Predispatch Energy

[Help](#)

For Market Participant A
Created at Apr 13, 2011 12:15:22
For Apr 14, 2011

Resource ID	C / U / Tag	MW Scheduled for Hour																							
		1	2	3	4	5	6	7	8	9	10	11	12	13	14	15	16	17	18	19	20	21	22	23	24
GENERATOR.G1	C	47.0	47.0	47.0	47.0	47.0	47.0	47.0	47.0	47.0	47.0	47.0	47.0	47.0	47.0	47.0	47.0	47.0	47.0	47.0	47.0	47.0	47.0	47.0	47.0
	U	47.0	47.0	47.0	47.0	47.0	47.0	47.0	47.0	47.0	47.0	47.0	47.0	47.0	47.0	47.0	47.0	47.0	47.0	47.0	47.0	47.0	47.0	47.0	47.0
GENERATOR.G2	C	25.0	25.0	25.0	25.0	25.0	25.0	25.0	25.0	25.0	25.0	25.0	25.0	25.0	25.0	25.0	25.0	25.0	25.0	25.0	25.0	25.0	25.0	25.0	21.1
	U	25.0	25.0	25.0	25.0	25.0	25.0	25.0	25.0	25.0	25.0	25.0	25.0	25.0	25.0	25.0	25.0	25.0	25.0	25.0	25.0	25.0	25.0	25.0	21.1
GENERATOR.G3	C	101.9	101.9	101.9	101.9	101.9	101.9	101.9	101.9	101.9	101.9	101.9	101.9	101.9	101.9	101.9	101.9	101.9	101.9	101.9	101.9	101.9	101.9	9.4	
	U	101.9	101.9	101.9	101.9	101.9	101.9	101.9	101.9	101.9	101.9	101.9	101.9	101.9	101.9	101.9	101.9	101.9	101.9	101.9	101.9	101.9	101.9	101.9	9.4
GENERATOR.G4	C	50.0	50.0	50.0	50.0	50.0	50.0	50.0	50.0	50.0	50.0	50.0	50.0	50.0	50.0	50.0	50.0	50.0	50.0	50.0	50.0	50.0	50.0	14.2	
	U	50.0	50.0	50.0	50.0	50.0	50.0	50.0	50.0	50.0	50.0	50.0	50.0	50.0	50.0	50.0	50.0	50.0	50.0	50.0	50.0	50.0	50.0	50.0	14.2
GENERATOR.G5	C	75.0	75.0	75.0	75.0	75.0	75.0	75.0	75.0	75.0	75.0	75.0	75.0	75.0	75.0	75.0	75.0	75.0	75.0	75.0	75.0	75.0	75.0	16.3	
	U	75.0	75.0	75.0	75.0	75.0	75.0	75.0	75.0	75.0	75.0	75.0	75.0	75.0	75.0	75.0	75.0	75.0	75.0	75.0	75.0	75.0	75.0	75.0	16.3
GENERATOR.G6	C	0.0	0.0	0.0	0.0	0.0	0.0	0.0	76.0	76.0	76.0	76.0	76.0	76.0	0.0	0.0	76.0	76.0	76.0	76.0	76.0	76.0	76.0	36.5	0.0
	U	0.0	0.0	0.0	0.0	0.0	0.0	0.0	76.0	76.0	76.0	76.0	76.0	76.0	0.0	0.0	76.0	76.0	76.0	76.0	76.0	76.0	76.0	76.0	0.0
GENERATOR.G7	C	0.0	0.0	0.0	0.0	0.0	0.0	5.2	5.2	5.2	5.2	5.2	5.2	5.2	5.2	5.2	5.2	5.2	79.9	79.9	79.9	5.2	5.2	5.2	56.5
	U	0.0	0.0	0.0	0.0	0.0	0.0	5.2	5.2	5.2	5.2	5.2	5.2	5.2	5.2	5.2	5.2	5.2	79.9	79.9	79.9	5.2	5.2	5.2	56.5
GENERATOR.G8	C	0.0	0.0	0.0	0.0	0.0	0.0	0.0	5.2	5.2	5.2	5.2	5.2	0.0	0.0	5.2	5.2	80.1	80.1	80.1	5.2	5.2	57.7	0.0	
	U	0.0	0.0	0.0	0.0	0.0	0.0	0.0	5.2	5.2	5.2	5.2	5.2	0.0	0.0	5.2	5.2	80.1	80.1	80.1	5.2	5.2	57.7	0.0	
GENERATOR.G9	C	45.0	45.0	45.0	45.0	45.0	45.0	45.0	45.0	45.0	45.0	45.0	45.0	45.0	45.0	45.0	45.0	45.0	45.0	45.0	45.0	45.0	45.0	45.0	
	U	45.0	45.0	45.0	45.0	45.0	45.0	45.0	45.0	45.0	45.0	45.0	45.0	45.0	45.0	45.0	45.0	45.0	45.0	45.0	45.0	45.0	45.0	45.0	
GENERATOR.G10	C	0.0	0.0	0.0	0.0	0.0	0.0	0.0	0.0	0.0	0.0	0.0	0.0	0.0	0.0	0.0	0.0	0.0	0.0	0.0	0.0	0.0	0.0	0.0	
	U	0.0	0.0	0.0	0.0	0.0	0.0	0.0	0.0	0.0	0.0	0.0	0.0	0.0	0.0	0.0	0.0	0.0	0.0	0.0	0.0	0.0	0.0	0.0	
GENERATOR.G11	C	0.0	0.0	0.0	0.0	0.0	0.0	0.0	0.0	0.0	0.0	0.0	0.0	0.0	0.0	0.0	0.0	0.0	0.0	0.0	0.0	0.0	0.0	0.0	
	U	0.0	0.0	0.0	0.0	0.0	0.0	0.0	0.0	0.0	0.0	0.0	0.0	0.0	0.0	0.0	0.0	0.0	0.0	0.0	0.0	0.0	0.0	0.0	

- The amount of generation that has been committed for the acceptance of the DA-PCG
- Information Included
 - MP Resource, MW constrained for PCG by Hour
- Issued only once, after EDAC Schedule of Record is declared and constraints for PCG eligible resources have been applied in the market tools

DACP Commitments

[Help](#)

for Market Participant #2
Created at Jan 06, 2009 15:50:09
For Jan 07, 2009

Resource ID	REL / GCG	MWConstrained for Hour																							
		1	2	3	4	5	6	7	8	9	10	11	12	13	14	15	16	17	18	19	20	21	22	23	24
GENERATOR.G1	REL																								
	GCG										100.0	100.0	100.0	100.0	100.0	100.0									
GENERATOR.G2	REL																								
	GCG						50.0	50.0	50.0	50.0	50.0	50.0	50.0	50.0	50.0										
GENERATOR.G3	REL																								
	GCG																		15.0	15.0					
GENERATOR.G4	REL																								
	GCG													60.0	60.0	60.0	60.0	60.0	60.0						
GENERATOR.G5	REL																								
	GCG								60.0	60.0	60.0														

Note: REL constraint to be removed

- A design requirement has been created to save the same data between passes as what is published at the conclusion of pass 3
- This data will be made available in the post-EDAC timeframe

- Primary means of communication will be via the Day 1 SSR
- Notification Messages will be sent for:
 - Delayed Results
 - Extension of ELR Re-Submission Window
 - No ELR Optimization
 - EDAC Re-Run Criteria being met
 - EDAC Failed
 - Solicitation of Bids/Offers for Reliability

- Initial Results should be available by 11:00
 - If not, the following notification will be sent
- ‘Initial Results Delayed’ and ‘ELR Window Extended’ as one notification including:
 - the time to expect results
 - the time the window will remain open, and
 - ELR Optimization Results will also be delayed

- ELR Optimization Results should be available by 13:00
- If not already delayed as per the previous slide a notification that 'ELR Results Delayed' will be sent when the ELR Optimization run is delayed, or must be re-run, for other reasons

- A notification of 'No ELR Optimization' is sent:
 - when there is not enough time remaining to complete a Run prior to 15:00, or
 - the Schedule of Record is published after a failed ELR Optimization run
- Notification that 'EDAC Re-Run Criteria has been met' and a subsequent run is required would be sent when conditions warrant.

- A notification of 'EDAC Failed' will be sent on the occasion that no EDAC Results have been produced, or the Results cannot be published to the Market Participants
 - If invalid results were inadvertently published as the Schedule of Record, an EDAC failure would also be declared
- System Advisories soliciting Bids/Offeres for:
 - over-generation, under-generation, O/R shortfall
 - A notification that the 'Condition is Rectified' will be sent when EDAC results indicate the above conditions have been resolved

- With the successful completion of EDAC, the Schedule of Record (SOR) is declared.
- Reports that comprise SOR are
 - Day Ahead Scheduled Energy – private report
 - Day Ahead Check/Source ADE – private report
- If any of the reports that comprise the ESOR fail to publish, EDAC fails

Note: The Public Day Ahead Adequacy Report no longer forms the SOR

- SOR will always be published by 15 EST
- SOR will be declared most days at 14 EST
- The set of valid results that was chosen to be the SOR will be stamped as such and republished; i.e., if the ELR Optimization Run results which are published by 14 EST are declared to be the SOR, they will be republished before 15 with a label to clearly identify them as the SOR

Real Time Market Integration of EDAC Results



- The incremental energy component of (new) Three-Part Offers accepted in EDAC will flow through to Real-Time
- Single-Part offers accepted in EDAC will flow through to Real-Time (as now)
- There will be no translation of Pseudo Unit Offers - Offers for physical units will be required in Real-time

- Bids/offers for Dispatchable Loads, Imports, Exports accepted in EDAC will flow through to Real-time
- Forecasts/Schedules for Non-Dispatchable resources accepted in EDAC will flow through to Real-time

- Bids and Offers **not** approved in EDAC will be flushed from the system at 14:00. They will **not** be carried forward for use in Real-time
- Daily Generator Data after 10:00 ~~the completion of EDAC will not be rejected and~~ will be used in the next days EDAC run (unless changed)

- Availability Declaration Envelope is established by 10:00 (or approved before 14:00) dispatch data:
 - All Dispatchable Resource *Dispatch Data* changes for the current day and the next day after the completion of EDAC (14:00) must not exceed the maximum bid/offer for each hour set during the previous day's EDAC process.
- RT changes to ADE must be IESO Approved

- Committed PCG eligible generators will have constraints applied into pre-dispatch and real-time scheduling process
- Minimum generator constraints are applied for the generator submitted MLP for a period equal to its EDAC schedule
- Participants cannot reject the commitment as a means to remove the constraints

Data Submission in RT



EDAC Data Submission Timeline

EDAC - Data Submission Timeline

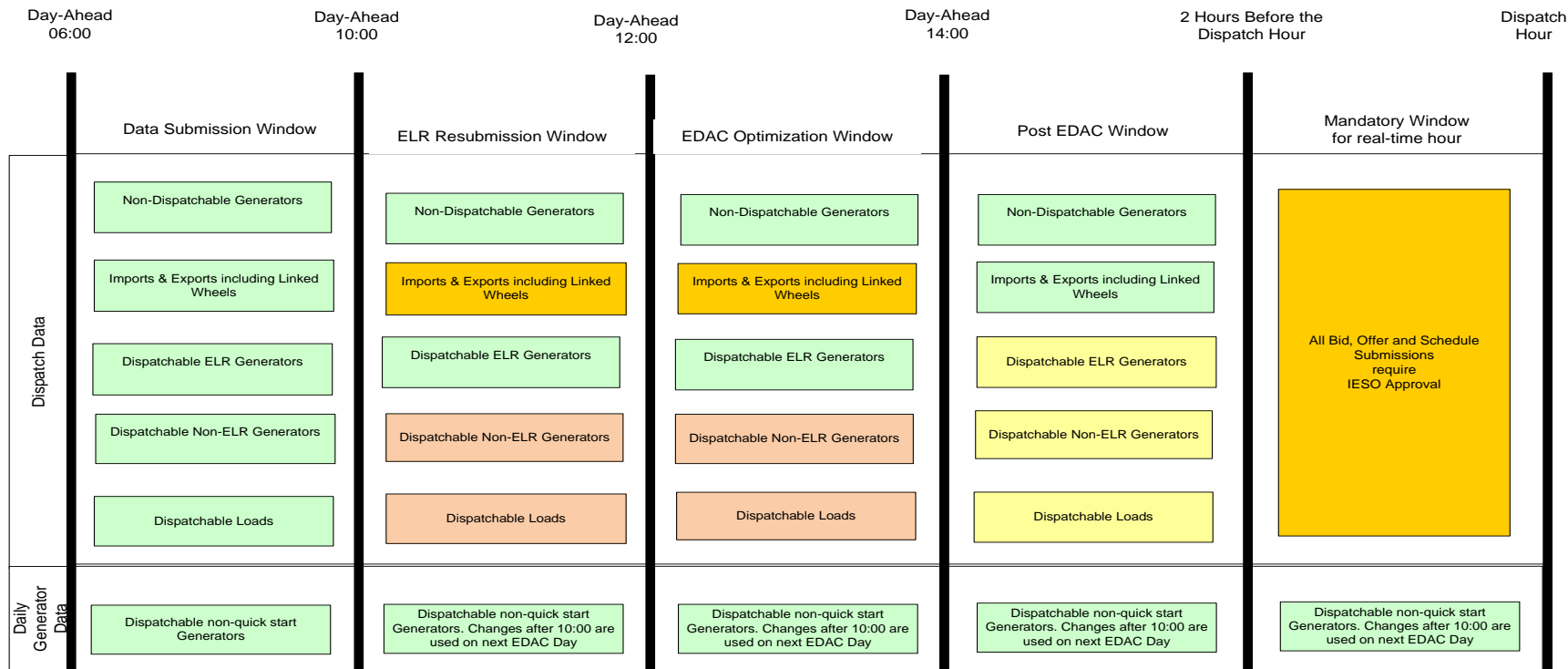

LEGEND



- All current rules apply for revisions to Dispatch Data
- MPI will automatically approve all valid submissions
- Revisions that exceed ADE will be scrutinized after the fact by Compliance (same as today)

Additionally:

- MLP price revisions to be validated
- Physical unit offers associated with pseudo units will be automatically approved, ADE established by pseudo unit offers in EDAC

- All current rules for revisions to dispatch data apply
 - Replacement energy offers allowed
 - IESO direction to submit for reliability
 - Changes in operational status of a facility to prevent violation of applicable law, endanger the safety of any person or damage property or the environment
 - Quantity in the current pre-dispatch schedule differs from the quantity that the MP reasonably expects to be delivered
- All submissions will be held for CRO approval

- The MLP Price submitted in EDAC sets the MLP Price Cap
- Revisions to MLP Price in RT will be validated against the Cap. If validation fails, the revision is automatically rejected and MP is informed that revision needs to be corrected and re-submitted
- Price of MLP in RT \leq Price of MLP in EDAC
- MLP Quantity can be determined in RT from the Daily Generator Submission
- MLP Price from the RT offer can be calculated

*****Solution will be complex*****

- Physical units and pseudo unit offers must be submitted before 10 EST of the EDAC Day
- At 10 EST a comparison is done to ensure that the MLP Prices of the CT and ST do not violate the associated PSU MLP Price
 - If n pseudo units are offered, then
 - CT_n MLP Price $<$ PSU_n MLP Price
 - ST_1 MLP Price $<$ $\max_{1 < x < n} PSU_x$ MLP Price
- MLP Price Cap for pseudo units and physical units is established in the same manner as other PCG eligible resources
- RT revisions to MLP Price of the physical units are validated like any other resource

Withdrawal and De-commit



- No change from current practices
- De-commitment will be at IESO direction for reliability concerns only, NOT economics
- Current Market Rules related to compensation will continue to apply

- MP calls CRO with withdrawal request
 - At time of request, MP must state if withdrawal is within their control or not
- CRO logs time and nature of request
- MP submits revised dispatch data
- Settlements will retrieve information to determine Withdrawal Charge (if any)

- A withdrawal request now includes a new Withdrawal Charge
- The Withdrawal Charge is calculated for a generator if the following 2 conditions are met:
 - The withdrawal was within the generator's control;
AND
 - It fails a price test
- The Withdrawal Charge will be assessed and applied if a generator withdraws prior to completion of its day-ahead commitment

- The Withdrawal Charge is assessed and applied in 2 ways according to when the notification occurred:
 - If withdraw notification is received at or 4 hours prior to real time (PD – 4), then the lesser of the PD Ontario MCP (PD-1) or the real-time Ontario MCP is used in the calculation
 - If withdraw notification is received later than PD-4, then, the real-time Ontario MCP is used in the calculation

- If withdrawal is outside of MP's control
 - PCG is prorated to the part of the MP's EDAC schedule that was delivered in RT
 - Resource must reach at least MLP to receive the prorated amount
- If withdrawal is inside of MP's control
 - Resource is not eligible for PCG