



CONNECTION ASSESSMENT & APPROVAL PROCESS

Preliminary Assessment Report

For 348 MVA New Generation at Thorold Proposed by Northland Power

Final Version

Long Term Forecasts & Assessments Department

December 8, 2000

Preliminary Assessment Report

For the proposed 348 MVA Development at Thorold
By Northland Power Inc.

Acknowledgement

The IMO wishes to acknowledge the assistance of Hydro One in completing some of the studies for this assessment.

Disclaimers

IMO

This report has been prepared solely for the purpose of assessing, on a preliminary basis, whether the connection applicant's proposed connection with the IMO-controlled grid would have an adverse impact on the reliability of the integrated power system and whether a System Impact Assessment of the proposed connection should be conducted under Chapter 4, section 6 of the Market Rules. This report has not been prepared for any other purpose and should not be used or relied upon by any person for another purpose. This report has been prepared solely for use by the connection applicant, Hydro One and the IMO in accordance with Chapter 4, section 6 of the Market Rules. The IMO assumes no responsibility to any third party for any use which it makes of this report. Any liability which the IMO may have to the connection applicant in respect of this report is governed by Chapter 1, section 13 of the Market Rules. In the event that the IMO provides a draft of this report to the connection applicant, you must be aware that the IMO may revise drafts of this report at any time in its sole discretion without notice to you. Although the IMO will use its best efforts to advise you of any such changes, it is the responsibility of the connection applicant to ensure that it is using the most recent version of this report.

Hydro One

Special Notes and Limitations of Study Results

The results reported in this preliminary feasibility study are based on the information available to Hydro One, at the time of the study, suitable for a preliminary assessment of a new generation or load connection proposal.

The results reported in this preliminary feasibility study are based on the information available to Hydro One, at the time of the study, suitable for a preliminary assessment of a new generation or load connection proposal.

The short circuit and thermal loading levels have been computed based on the information provided by the connection proponent at the time of the study. These levels may be higher or lower if the connection information changes as a result of, but not limited to, subsequent design modifications or when more accurate test measurement data is available.

This study does not assess the short circuit or thermal loading impact of the proposed connection on facilities owned by other load and generation (including OPGI) customers.

In this preliminary feasibility study, short circuit adequacy is assessed only for Hydro One breakers and does not include other Hydro One facilities. The short circuit results are only for the purpose of assessing the capabilities of existing Hydro One breakers and identifying upgrades required to incorporate the proposed connection. These results should not be used in the design and engineering of new facilities for the proposed connection. The necessary data will be provided by Hydro One and discussed with the connection proponent upon request.

The ampacity rating of Hydro One facilities are established based on assumptions used in Hydro One for power system planning studies. The actual ampacity ratings during operations may be determined in real-time and are based on actual system conditions, including ambient temperature, wind speed and facility loading, and may be higher or lower than those stated in this study.

The additional facilities or upgrades which are required to incorporate the proposed connection have been identified to the extent permitted by a preliminary assessment. Additional facility studies may be necessary to confirm constructability and the time required for construction. System impact or further studies at more advanced stages of the project development may identify additional facilities that need to be provided or that require upgrading.

Preliminary Assessment Report

For the proposed 348 MVA Development at Thorold
By Northland Power Inc.

Executive Summary

This Preliminary Assessment investigates the impact of the proposed Thorold development on the reliability of the local system, in isolation of other proposed developments.

Incorporation of Proposed Project

Northland Power Inc. proposes to construct two gas-turbine generators, 116 MVA each and one steam turbine generator of 116 MVA, for a total of 348 MVA in a new generating facility on the Donahue site in Thorold. It is proposed to connect the new generating facility to the transmission system via a 230 kV tap off 230 kV circuit Q10P in the proximity of the Donahue complex. The proposed project will be connected to the single circuit line Q10P, which is normally supplied from the 230 kV line Q32A or alternatively supplied from the 230 kV line Q26A.

The proposal is to connect each generator unit through a step-up transformer, and a HV breaker to a new 230 kV bus. The new 230 kV bus will be connected to the existing system through a HV breaker, a 400 meter line and a disconnect switch designated as 89-LI-Q10P-X.

Impact on Transfer Capability

The studies which were performed indicate that the addition of the proposed 348 MVA project at Thorold has the following impact on the transfer capability of the local transmission facilities:

- overloading of the 230 kV circuit Q10P above its continuous rating;
- increased flow through the Allanburg transformer T4 (but the resulting power did not exceed the continuous of post-contingency transformer rating); and,
- increased flow over the Queenston Flow West interface by a maximum of 238 MW (but the operating limit was not exceeded).

This report identifies measures that need to be taken to mitigate the impact of the proposed project on the local transfer capability; however, a feasibility assessment of these measures was not carried out.

Impact on Fault Levels

The fault analysis studies which were performed indicate that due to the increased fault levels resulting from the addition of the Northland Power development at Thorold:

- the capability of four of the 230 kV breakers at Beck GS#2 will be exceeded;
- the capability of eight 115 kV breakers at Allanburg will be exceeded; and,
- the capability of the 230 kV breakers at Middleport will not be exceeded.

Consequently, it is necessary to further investigate remedial options that will resolve the breaker overloading problem at Allanburg and Beck GS#2 before allowing the incorporation of the proposed 348 MVA development at Thorold.

1. Background

Northland Power Inc. proposes to construct two gas-turbine generators, 116 MVA each and one steam turbine generator of 116 MVA, for a total of 348 MVA in a new generating facility on the Donahue site in Thorold. It is proposed to connect the new generating facility via a tap off 230 kV circuit Q10P in the proximity of the Donahue complex.

The proposed in service date for the project is late 2001.

The geographical location of the proposed new generating station is shown in figure 1. Figure 2 represents a schematic diagram of the transmission system in the area of the proposed connection.

2. Connection Arrangement

The proposed project will be connected to the single circuit line Q10P, which is normally supplied from the 230 kV line Q32A or alternatively supplied from the 230 kV line Q26A as shown in Figure 3. This Figure shows details related to the proposed arrangement of the generating facility as well as the existing Q10P connection arrangement onto Q26A and Q32A. As shown, Q10P is a 1.8 km single circuit line equipped with 795kcmil conductor tapped off from Quno junction. Quno Junction is about 2 km away from the tap points on Q26A and Q32A.

The proposal is to connect each unit through a step-up transformer, and a HV breaker to a 230 kV bus. The new 230 kV bus will be connected to the existing system through a HV breaker, a 400 meter line and a disconnect switch designated as 89-LI-Q10P-X. The single line diagram submitted by the proponent, designated 1252ESK indicates that the disconnect switch is not motorized.

3. Data Verification

The data provided by the connection applicant was incomplete in some areas. It has been agreed with the applicant that, where possible, typical data will be used in the Preliminary Assessment, with the understanding that all of the required information will be supplied for the System Impact Assessment.

3.1 Generator Model

The inertia constant 'H' for the generators was not provided, a value of 4.5 is assumed for each generator. Data for each generator model is shown in Figure 3 attached.

The 'Estimated Reactive Capability Curves' provided by the applicant indicate that, at rated active power output and 40⁰ C ambient temperature, each unit is only capable of absorbing about 16 MVARs. This does not meet the Market Rules requirement of about 34 megavars. The Market Rules state that each synchronous facilities connected to the IMO-Controlled Grid shall have the capability to supply reactive power within the range between 90% lagging (overexcited) and 95% leading (underexcited) power factor based on rated active power at rated voltage. However, from the same curve it can be estimated that the reactive power producing capability each of the unit is 60 MVARs which exceeds the 44 MVARs required capability corresponding to the Market Rules

requirements. Therefore, it is considered that the range of reactive power capability meets the 15% range specified in the Market Rules.

Historical records of voltages in the area show that maximum voltage at Beck could reach 239 kV and minimum can go as low as 226 kV. These records indicate that voltages in the area do not present a problem. Hence, it is concluded that the lower than required MVAR absorbing capability of the generating units will not have a detrimental impact on the of the local area voltages.

3.2 Governor Model

The connection applicant did not provide a governor model . The PTI governor model 'IEEEG1' was assumed. The block diagram and the data used for this governor are shown in Appendix 1, and the governor response test is shown in Appendix 2.

3.3 Excitation System

The exciter model provided for each unit (IEEE ST4B - EX2000 Busfed Exciter Model) is a non Standard PTI model. In order to verify the exciter data provided a similar PTI model, 'EXPIC1', was used. The block diagram and the data for this exciter are shown in Appendix 3. Open circuit test results on this excitation model are shown in Appendix 4.

Power system stabilizers are missing from the data supplied. Due to the proposed size of each generator, IMO's requirement is to have a stabilizer installed on all the units at the station. The data on the power system stabilizer will have to be provided before the start of the System Impact Assessment.

3.4 Synchronizing Breaker on the LV side of the Step Up Transformer

The Transmission System Code requires any generator or load connected to the IMO-controlled grid, to have a point of isolation from the transmission system via a high-voltage interrupting device (HVI). The configuration proposed by the applicant shows a disconnect switch (89-LI-Q10P-X) in place of the HVI device. This arrangement does not correspond to the requirements of the code. However, the TSC leaves it up to the transmitter, Hydro One in this case, to authorize alternate interrupting device installations. In this case the additional 400m of line construction into the station will marginally increase the exposure to faults, which may be deemed negligible by the transmitter, thus allowing the HV breaker (52-Q10P) to clear the system faults.

The single line diagram provided does not show a LV synchronizing breaker. According to the Transmission System Code, a synchronizing breaker on the LV side is required. This breaker should be able to interrupt all fault current from all the system as well as from the generator itself. In the absence of the LV breaker, the HT breakers '52-Q10P-X', '52-GTG-1', '52-GTG-2' and '52-GTG-3' should be rated such that they are capable of interrupting the full fault current from the system as well as from the generator.

An alternative to the use of a HT synchronizing breaker is to install a LV synchronizing breaker with a disconnect switch on the HV side. Details for this arrangement can be obtained from the Transmission System Code.

3.5 Unit Transformer Rating (IEEE Recommended Standard)

Based on the IEEE Guide for Transformers, the highest unit transformer tap should be rated at 5% below the maximum system voltage. The maximum voltage on the 230 kV system is 250 kV in Ontario.

3.6 Drawing '1252ESK1' dated July 25, 2000

The above single line diagram did not show how the station service load is to be fed. A drawing similar to the Kirkland Lake Unit 3 Protection (Drawing No. 1245XE01) would be helpful in understanding the connectivity of the proposed site.

4. Short Circuit Assessment

Based on a preliminary review of the impact of the proposed connection on the short circuit levels in the area, it was identified that a large number of breakers may be exposed to fault levels above their ratings, both at Allanburg TS and Beck #2 GS.

Fault level studies were performed to determine more accurately the effect of the proposed connection on the existing transmission facilities. The study case was configured to represent all generation in service, which creates the worst possible scenario for fault levels.

The following assumption were made when conducting the studies:

- All existing transmission facilities in service,
- Sithe 800 MW and 900 MW developments in Mississauga and Brampton respectively in service,
- Transalta Energy Corp. 580 MVA development in Sarnia in service,
- AES Power 625 MVA development at Leamington in service,
- ATCO Power 680 MVA development in Windsor in service,
- ENRON 610 MVA development at Lambton in service,
- The 115 kV bus at Allanburg was operated solid,
- Nanticoke has eight units in service,
- Middleport bus is operated split (required operation for full Nanticoke output)
- Pickering A units in service,
- Prefault voltages of 127 kV and 250 kV on the 115 kV and 230 kV systems, respectively,
- All Beck units in service.

Initial analysis of the short circuit levels indicates that as a result of connecting the new generators, the short circuit ratings may be exceeded for a number of breakers at the neighbouring stations. The rated capability of the breakers was used in assessing the breaker capability to interrupt the current resulting from the fault.

It has been estimated that the contribution to short circuit levels of the new proposed Sithe development, together with the Sarnia-Winsor developments, is very small, and only amounts to about 50 A.

4.1 Fault Levels at Allanburg

The maximum fault levels at Allanburg before and after the incorporation of Thorold development are summarized in Tables 1 and table 2 respectively.

Table 1. Fault Levels at Allanburg – Without the Thorold Development

Breaker	Rated Sym (kA)	Rated Asym (kA)	Breaker Interrupting Fault Level (kA)				Percentage of Rating			
			3-Phase		Line-to-Ground		3-Phase		Line-to-Ground	
			Sym	Asym	Sym	Asym	Sym	Asym	Sym	Asym
D1D2	40.2	46.5	37.1	45.9	39.6	44.2	92.3	98.8	98.5	95.1
DL1	40.7	45.5	35.4	43.8	37.7	42.1	87.1	96.4	92.8	92.6
DL3	39.3	45.5	35.3	43.7	38.4	42.9	89.9	96.2	97.8	94.3
DL36	40.2	46.5	35.6	44.1	38.1	42.5	88.8	95.0	94.9	91.5
H1H2	40.2	46.5	34.3	42.5	37.1	41.4	85.5	91.4	92.4	89.1
HL3	40.2	46.5	35.3	43.7	38.4	42.9	88.0	94.1	95.7	92.3
HL37	40.2	46.5	35.6	44.1	38.0	42.4	88.7	94.9	94.7	91.3
HL6	40.2	46.5	36.6	45.3	39.6	44.2	91.2	97.6	98.7	95.2
HL7	40.7	45.5	36.6	45.3	39.6	44.2	90.1	99.7	97.5	97.3
L1L6	41.9	45.5	36.6	45.3	39.6	44.2	87.4	99.7	94.5	97.3
L7L36	40.2	46.5	36.6	45.3	39.6	44.2	91.2	97.6	98.7	95.2
T3D	40.2	46.5	37.1	45.9	39.6	44.2	92.3	98.8	98.5	95.1
T3L37	40.2	46.5	35.6	44.1	38.0	42.4	88.7	94.9	94.7	91.3
T4D	50.0	56.8	37.1	45.9	39.6	44.2	74.1	80.8	79.1	77.7
T4H	40.2	46.5	34.3	42.5	37.1	41.4	85.5	91.4	92.4	89.1

Table 2. Fault Levels at Allanburg – With the Thorold Development

Breaker	Rated Sym (kA)	Rated Asym (kA)	Breaker Interrupting Fault Level (kA)				Percentage of Rating			
			3-Phase		Line-to-Ground		3-Phase		Line-to-Ground	
			Sym	Asym	Sym	Asym	Sym	Asym	Sym	Asym
D1D2	40.2	46.5	38.0	47.6	40.9	46.5	94.6	102.4	101.8	100.0
DL1	40.7	45.5	36.3	45.5	39.1	44.4	89.3	100.1	96.1	97.6
DL3	39.3	45.5	36.2	45.4	39.8	45.2	92.2	99.9	101.4	99.5
DL36	40.2	46.5	36.5	45.8	39.5	44.8	91.0	98.6	98.3	96.5
H1H2	40.2	46.5	35.2	44.1	38.5	43.7	87.7	95.0	95.8	94.1
HL3	40.2	46.5	36.2	45.4	39.8	45.2	90.2	97.7	99.2	97.4
HL37	40.2	46.5	36.5	45.8	39.4	44.7	91.0	98.5	98.1	96.3
HL6	40.2	46.5	37.5	47.0	41.0	46.5	93.5	101.3	102.0	100.2
HL7	40.7	45.5	37.5	47.0	41.0	46.5	92.3	103.5	100.8	102.3
L1L6	41.9	45.5	37.5	47.0	41.0	46.5	89.5	103.5	97.7	102.3
L7L36	40.2	46.5	37.5	47.0	41.0	46.5	93.5	101.3	102.0	100.2
T3D	40.2	46.5	38.0	47.6	40.9	46.5	94.6	102.4	101.8	100.0
T3L37	40.2	46.5	36.5	45.8	39.4	44.7	91.0	98.5	98.1	96.3
T4D	50.0	56.8	38.0	47.6	40.9	46.5	76.0	83.8	81.8	81.8
T4H	40.2	46.5	35.2	44.1	38.5	43.7	87.7	95.0	95.8	94.1

As indicated in Table 2 above, with the Thorold units in service, eight out of the fifteen breakers at Allanburg are inadequately rated to interrupt the current resulting from three phase or a line to ground faults. The breaker ratings are exceeded by up to 3.5 % as shown in **bold**

The maximum fault levels imposed on the Allanburg 115 kV bus are listed in table 3 for reference.

Table 3. Fault Levels at the Allanburg Bus

	Fault level at the 115 kV bus at Allanburg				Breaker Capability	
	3-Phase Fault		Line to Ground Fault		Sym	Asym
	Symmetrical	Asymmetrical	Symmetrical	Asymmetrical		
Existing	37.1	45.9	39.6	44.2	39.3	45.5
With 3-unit Thorold Development	38.0	47.6	41.0	46.5		

4.2 Beck GS#2 Breakers

Analysis of the fault levels imposed on the breakers at Beck GS#2 with the new Thorold development incorporated indicates that only the asymmetrical line to ground fault levels are of concern. Studies show that the short circuit currents imposed on four of the breakers at Beck GS#2 are over their rated capability and the breakers require upgrading. The information is provided in table 4 below.

Table 4. Fault Levels at Beck

Breaker	Rated Asym (kA)	Station Asym Fault (no Thorold) (kA)	Station Asym Fault (with Thorold)	Interrupting Asym Fault (kA)	% Rated Asym (with Thorold)
DL24	81.5	78.9	82.2	81.7	100.2
KL23				81.8	100.4
TL21L23				81.7	100.2
TL21L24				81.8	100.4
DT301	83.2	78.9	82.2	82.2	98.8
DT302				82.2	98.8
KL25				81.9	98.4
KL29				82.0	98.6
L25T302				82.2	98.8
L28T301				82.2	98.8
TL28L29				82.0	98.6

It should be noted that the ratings of the breakers were obtained from the nameplate and that further confirmation with regard to the actual capability must be sought from the manufacturer. Also, the studies were carried out with the available New York system model. This model is undergoing revisions and could have an impact on the results of future short circuit studies that will be carried out as part on the SIA work.

5 Local Thermal Loading Considerations

Information provided by Hydro One indicates that the Q10P line has a summer continuous rating of 228 MVA (15 minute LTR of 232 MVA) with a sag temperature of 60°C. The output of the Thorold generation will have to be restricted at all times to meet Q10P thermal limitations unless the circuit is upgraded.

It is recommended that the sag clearance be raised for a maximum operating temperature of 75⁰ C or higher. This will increase the ratings of Q10P to 285 MVA continuous (322 MVA 15-min LTR). This should accommodate the full generation output of the Thorald Project under most loading conditions at Donahue. It will be up to the proponent to assess their risk of generation bottling.

6. Impact on Interface Flows

Preliminary assessment of the impact of the new proposed generation on interface flows was performed assuming the most onerous expected power transfers, but under solid system conditions. The studies were carried out under the following main assumptions:

- All existing transmission facilities are in service.
- The Ontario load is at the 2000 summer peak level,
- A net transfer of 660 MW through the four Allanburg 230/115 kV transformers into the Allanburg 115 kV pocket. This study scenario is very close to the maximum Allanburg transformer loading recorded during 1999.
- Northland generation at Thorold is at the maximum rated power of 294 MW.
- Donahue load is 61 MW,
- Q10P is normally configured, thus connected to Q32A.

The study concentrated on determining the impact of the new connection on the local transmission facilities. A number of simulations were performed to cover the system with all elements in service, single contingency and double contingency situations. All the investigations were done using the PTI linear analysis tool.

A first set of simulations was performed to determine the change in interface power flows when the new generation at Thorold displaces the power generated at various stations in Ontario. Table 5 below summarizes these results.

Table 5. Generation Shift Factors with all elements in service

Interface	Location of generation displaced by the Thorold proposal						
	Beck 1	Pickering	Nanticoke	Lambton	Lennox	NY	Michigan
Beck2-Donahue Jct.	-0.588	-0.827	-0.826	-0.828	-0.827	-0.832	-0.830
BLIP	-0.004	-0.107	-0.117	0.659	0.086	0.193	0.519
NY@Niag	0.007	0.232	0.203	0.361	0.273	0.654	0.455
Mi-Ont	-0.004	-0.107	-0.117	-0.341	-0.086	0.193	0.519
FETT	-0.003	0.875	-0.086	-0.020	0.813	0.153	0.026
QFW	-0.007	0.768	0.797	0.639	0.727	0.346	0.544

As an example, the sixth column in Table 5 indicates that when Thorold generation is used to displace Lennox generation, about 73% of Thorold generation appears on the QFW interface and 27% on the Niagara interface (4x230 kV circuits to NY).

The results also indicate that, in the simulations where the Thorold generation displaces any major generator in Ontario other than Beck GS#1, about 82% of the Thorold generation is distributed towards Beck GS#2 and 18% flows towards Allanburg TS. The incremental power received at Allanburg then flows into the station through T4 and circulates back to the 230 kV system through the other three transformers. Table 6 below shows the power distribution through the Allanburg transformers.

Table 6. Generation Shift Factors on Allanburg Transformers

Interface	Location of generation displaced by the Thorold proposal						
	Beck 1	Pickering	Nanticoke	Lambton	Lennox	NY	Michigan
Allanb T4	0.412	0.173	0.174	0.172	0.173	0.168	0.170
Allanb T3	0.199	-0.086	-0.088	-0.081	-0.084	-0.069	-0.077
Allanb T1	0.194	-0.044	-0.043	-0.045	-0.044	-0.049	-0.046
Allanb T2	0.195	-0.044	-0.043	-0.045	-0.044	-0.049	-0.047

The coefficients listed in the tables can help identify situations when congestion of various transmission interfaces may occur for different generation dispatch conditions.

A second set of simulations was performed to calculate the outage distribution factors for the most critical contingency with respect to the loading of the Allanburg transformers; the loss of the double circuit line Q26A and Q28A. The Q26A/Q 28A double contingency will result in the loss of T1 and T2 at Allanburg and the loading of the remaining two transformers which will supply the Allanburg 115 kV pocket. Post-contingency studies were carried out for Donahue load at 61 MW and Donahue load off. Table 7 below summarizes the results of the post-contingency simulations.

Table 7: Pre and post-contingency flows on Allanburg T4 transformer

	Pre-contingency loading		Post-contingency (Q26A+Q28A)	
	Loading @ Allanburg T4 (MW)	% of Continuous 248 MVA	Loading @ Allanburg T4 (MW)	% of 15 Minute LTR 438 MVA
Summer 2000 Peak Base Case	179	72%	371	85%
Thorold@ 294 MW with 61 MW load @ Donohue	230	93%	410	94%
Thorold@ 294 MW with zero load @ Donohue	240	97%	418	95%

The results of the study show that with Thorold generation on, the loading of the Allanburg T4 transformer increases but it is within the continuous rating and the post-contingency rating of the transformer. Overloading of T4 at Allanburg is not a concern.

The load flow studies also indicate that station voltages in the area are in the order of 235 kV and do not present a concern. The addition of the proposed generation does not have a negative impact on voltages.

Lastly, a high level evaluation of the impact of the proposed facility on Queenston-Flow-West was performed, to give a general idea of the contribution of the new facility to transmission congestion in the area. The Queenston Flow West (QFW) interface is limited to 2030 MW in the winter and 1830 MW in the summer due to post-contingency thermal ratings of the circuits. Historical records of the OFW power flows for the last twelve months, although very preliminary, show that most of the time the flow on this interface was well below the transfer limit. In fact records indicate that the QFW flow was above 1200 MW for about 5% of the time. Based on the distribution factors obtained through the studies it can be calculated that Thorold generation contributes up to 238 MW to the QFW interface flow (298 MW*80%).

Hence, based on the preliminary assessment carried out at this time it is concluded that the generation at Thorold has an impact on flow west of Queenston, but the total power flow will be well below the QFW limit. This conclusion is based on power flow behaviours that were driven by the regulated electricity market. It is difficult to predict how the electricity industry deregulation and introduction of competition will affect the transmission interface power transfers and therefore this statistical information may not be a good indication of future trends.

The contribution of Thorold generation to the possible congestion of other transmission interfaces in Ontario will be studied as part of the System Impact Assessment.

7. Discussion – Alternative Connection

The radial line Q10P can be connected to the grid via tapping onto Q32A or alternatively onto Q26A. Under normal operating conditions, Q10P is connected to Q32A and the disconnect switch to Q26A is normally open. It has been previously determined that the connection of Q10P to circuit Q26A will contribute to the overloading of T1 at Allanburg; T1 is rated at 225 MVA. As shown in Figure 2, Q26A is connected at Allanburg to T1 and any increase in the Q26A flow towards Allanburg will impact on the loading of this transformer. A quick assessment (based on the assumption that when Q10P is connected to Q26A the power injected by the Thorold development into the system will distribute in a similar way as under the normal connection - Q10P connected to Q32A), shows that T1 at Allanburg may become thermally overloaded in pre-contingency conditions. The formula used is:

$$\text{Allanburg T1(with Thorold)} = \text{Allanburg T1(without Thorold)} + 0.18 * (\text{Thorold Generation})$$

For a transformer T1 Loading of 180MW before the Thorold connection to Q26A, a power flow equivalent to 233MW will be injected into T1.

It is recommended that the connection of Q10P to Q26A not be used unless the generation at Thorold will be backed up to respect the continuous rating of Allanburg T1 transformer.

8. Conclusions

The following conclusions can be drawn from the results of these studies:

- The incorporation of 348 MVA generation at Thorold will increase the fault levels at Allanburg TS and Beck GS#2 beyond the rated capability of some of the existing breakers.
- The incorporation of the 348 MVA generation at Thorold will increase the flow through the Allanburg transformer T4 but the resulting power will not exceed the continuous or post-contingency transformer ratings.
- Incorporating the Thorold generation will cause the loading of the 230 kV circuit Q10P to exceed its continuous rating.
- Incorporating the Thorold generation will increase the Queenston Flow west by a maximum of 238 MW.

9. Preliminary Connection Requirements

The following system modifications are required by the IMO in order to mitigate adverse reliability impacts imposed by the Thorold development on the IMO-controlled grid:

- Upgrade eight of the 115 kV breakers at Allanburg.
- Upgrade at least four breakers at Beck GS#2.
- Upgrade the 230 kV circuit Q10P to at least 75⁰C operating temperature and accept operating restrictions under low load scenarios at Donahue. Upgrading to a higher operating temperature is an option if the proponent wants to produce full plant capability at all times.

In addition to the above preliminary requirements, the applicant should consider connecting onto the 230 kV circuit Q32A rather than onto Q26A. If under certain system conditions Q10P must be connected to Q26A, then operating restrictions are likely to be imposed by the IMO.

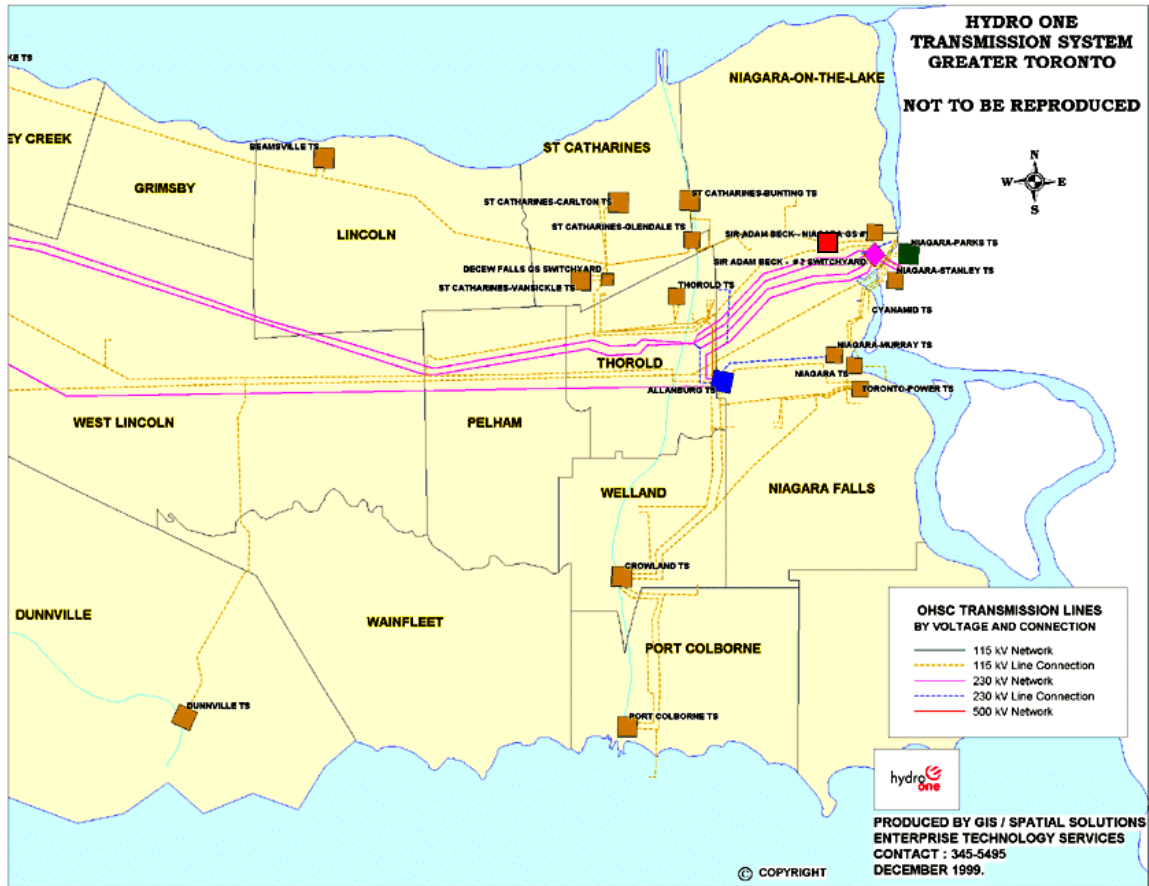

Figure 1. Niagara Area Transmission System

■ Northland New Generation

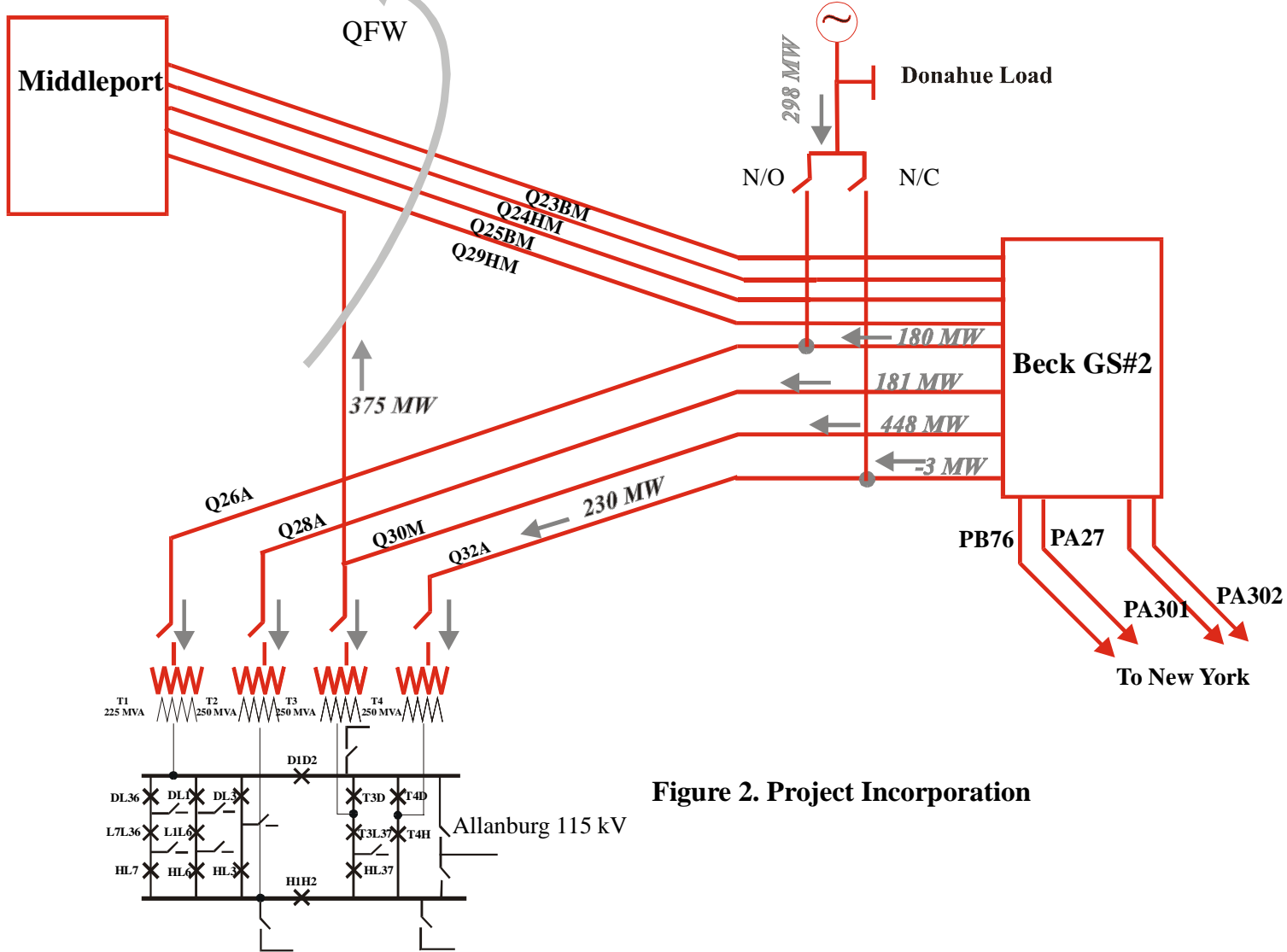
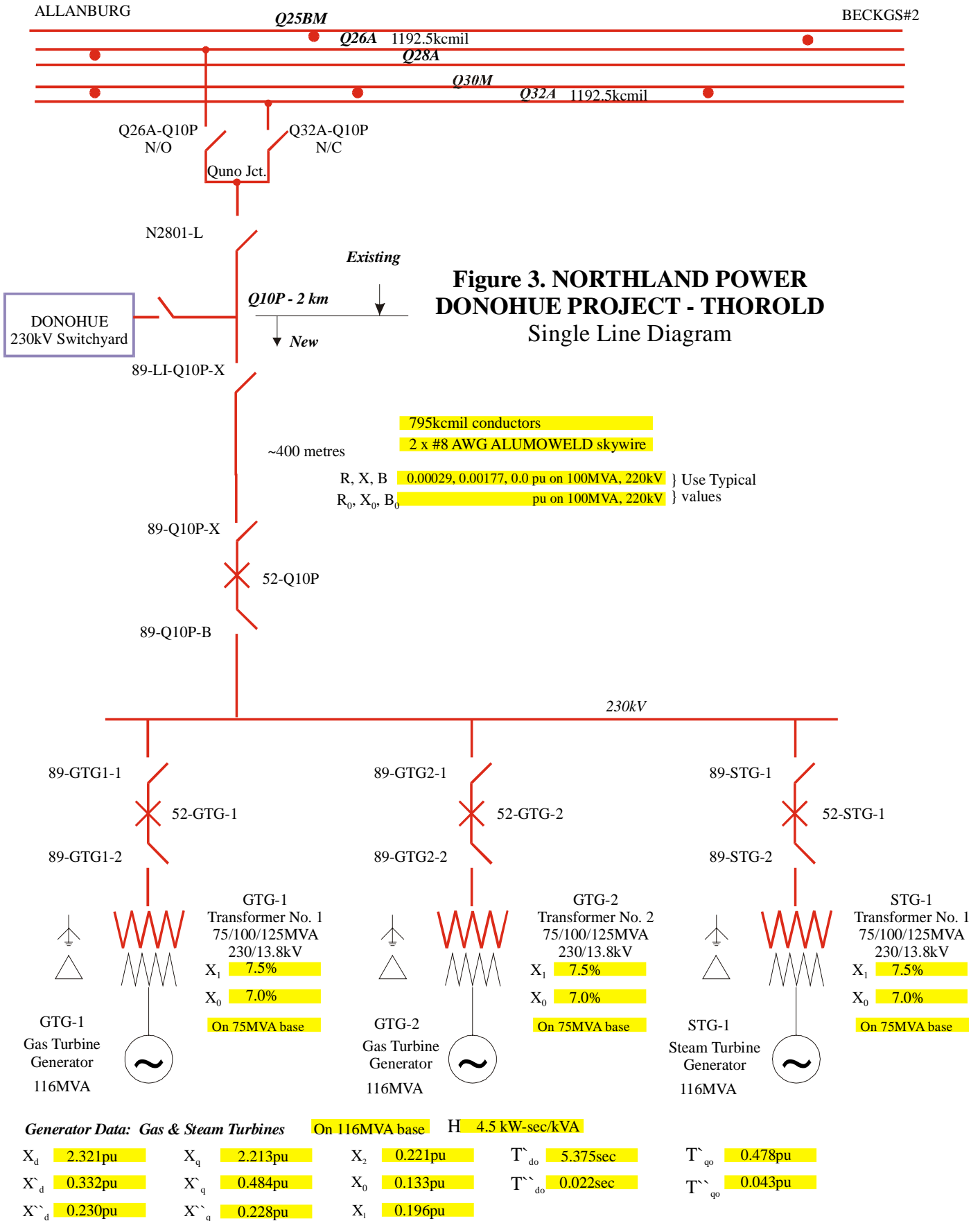

Figure 2. Project Incorporation



Appendix 1

IEEE Type 1 Speed-Governing Model

Thorold G1, G2 & G3

20.0	K
0.0	T ₁ (Seconds)
0.0	T ₂ (Seconds)
0.1	T ₃ (>0) (Seconds)
0.1	U _o (p.u. / Second)
-0.1	U _c (<0) (p.u. / Second)
1.0	P _{MAX} (p.u. on Machine MVA Rating)
0.0	P _{MIN} (p.u. on Machine MVA Rating)
0.5	T ₄ (Seconds)
1.0	K ₁
0.0	K ₂
0.0	T ₅
0.0	K ₃
0.0	K ₄
0.0	T ₆ (Seconds)
0.0	K ₅
0.0	K ₆
0.0	T ₇ (Seconds)
0.0	K ₇
0.0	K ₈

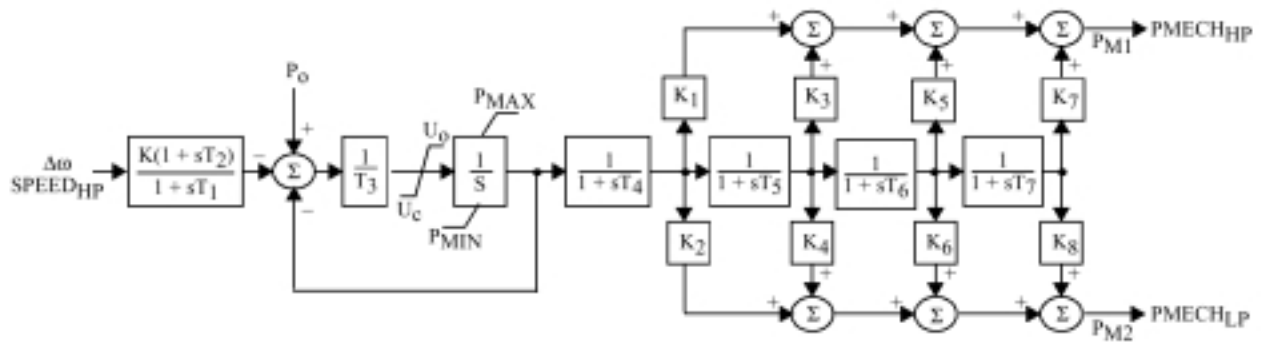

Preliminary Assessment: Northland Power Abitibi Thorold Project

Appendix 2: Governor Response Test

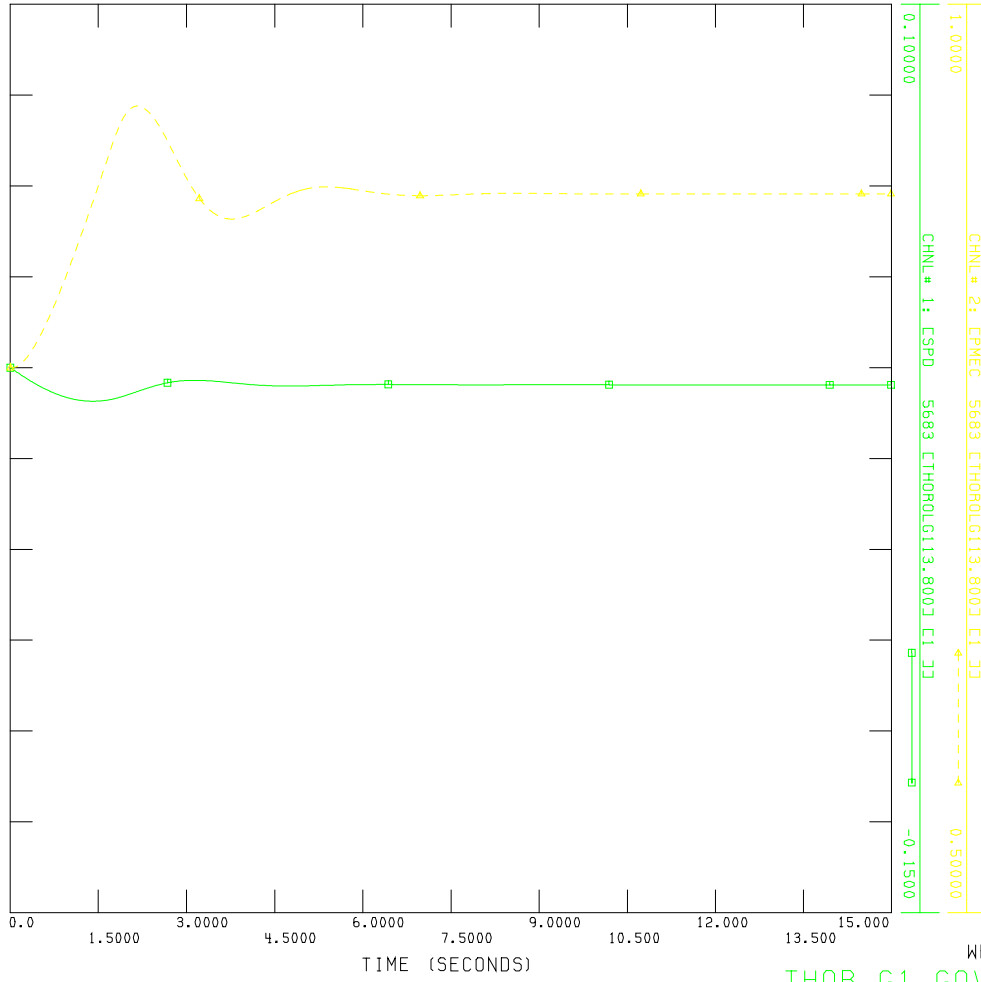

THOROLD0294, 600TOMI, 1500FNY, 200FMA 487N4P4LB4LK3D0AT
 BLIP, 1290_FABC, 3006_O-M, 601_FN-785_FETT, 3165_EME, 186_CEL, 2624

FILE: gstrt.out

WED, NOV 22 2000 13:48
 THOR G1 GOVNROR RESP TEST

Preliminary Assessment: Northland Power Abitibi Thorold Project

Appendix 3

Proportional / Integral Excitation System 'EXPIC1'

Thorold G1, G2 or G3

0.0	T_R (Seconds)
3.4	K_A
1.0	T_{A1} (Seconds)
1.0	V_{R1}
-0.87	V_{R2}
0.010	T_{A2} (Seconds)
1.0	T_{A3} (Seconds)
1.0	T_{A4} (Seconds)
1.0	V_{RMAX}
-0.870	V_{RMIN}
0.0	K_F
500.0	$T_{F1} (>0.)$ (Seconds)
500.0	T_{F2} (Seconds)
40	EFD_{MAX}
-40	EFD_{MIN}
0.0	K_E
0.0	T_E (Seconds)
1.0	E_1
0.0	SE_1
1.2	E_2
0.0	SE_2
5.840	K_P
0.0	K_I
0.070	K_C

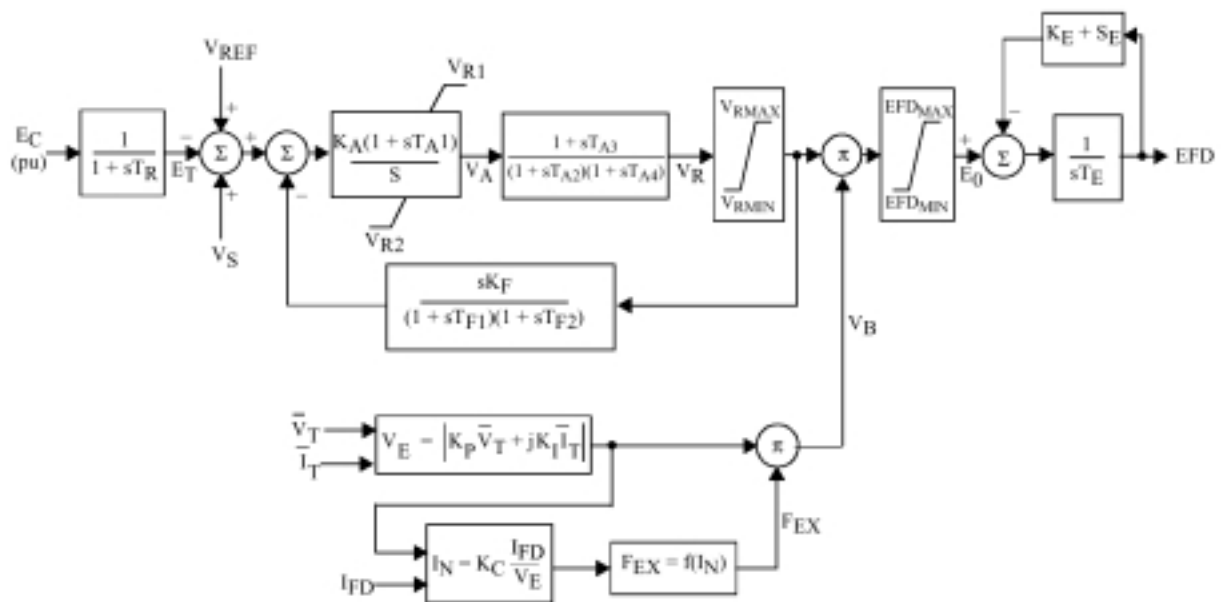

$$V_S = V_{OTHSG} + V_{UEL} + V_{OEL}$$

Preliminary Assessment: Northland Power Abitibi Thorold Project

Appendix 4: Exciter response test



THOROLD0294.600TOMI.1500FNY.200FMA 4B7N4P4LB4LK3D0AT
 BLIP.1290_FABC.3006_0-M.601_FN-785_FETT.3165_EWE.186_CE.2624

FILE: estrt.out

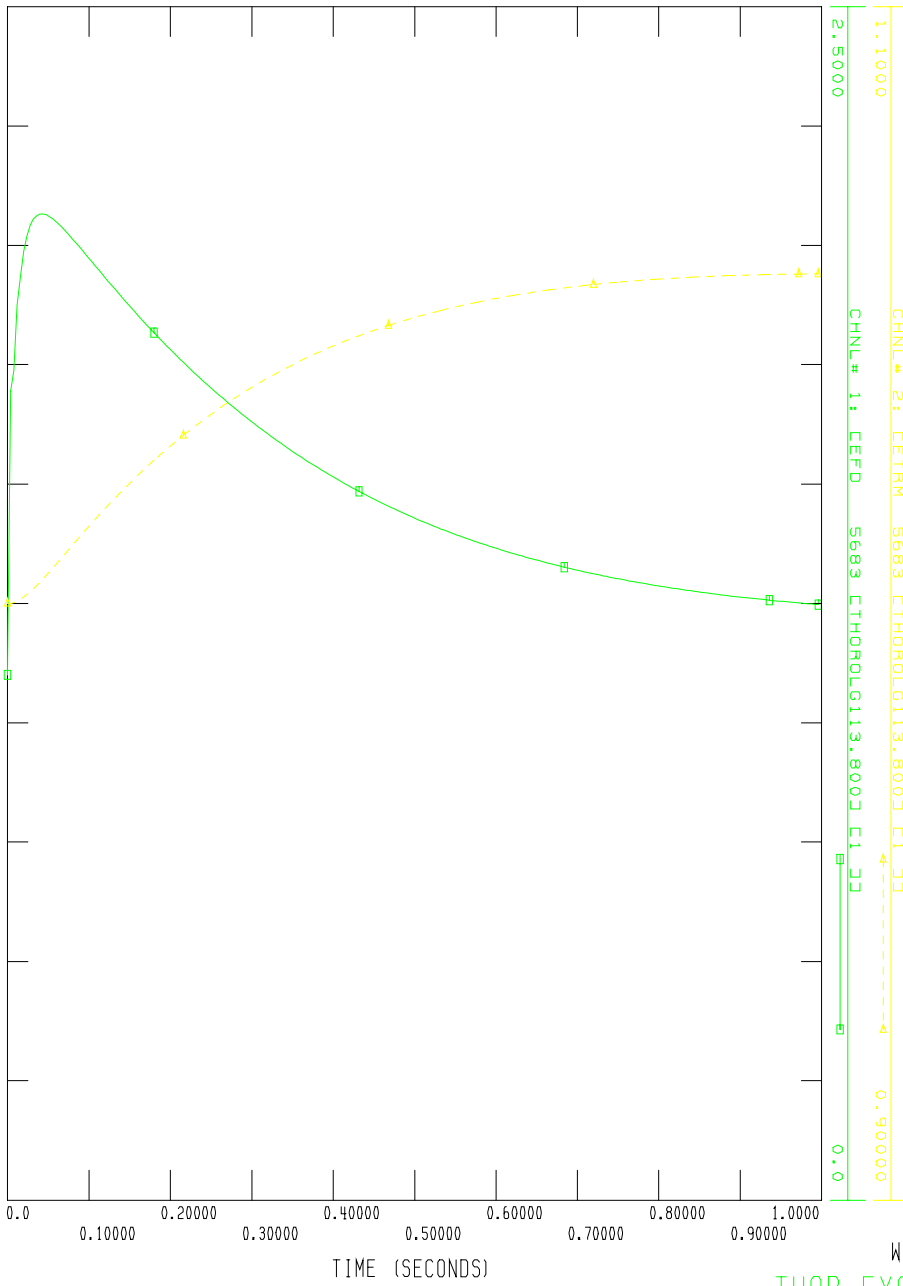

WED, NOV 22 2000 13:46
 THOR EXCITER RESP TEST