



7th April 2004

Mr Mel Yates
Manager-Stations T&D: Sustainment Programs
Hydro One Networks Inc.
483 Bay Street, 15th Floor: North Tower
Toronto M5G 2P5
Ontario

Dear Mr Yates:

***Lakeview SS: Isolate the 'B'-winding of the RSS2 Transformer
Notification of Approval of Connection Proposal
CAA ID Number: 2004-EX193***

Thank you for the data provided on the proposed isolation of the 4.16kV connections to the 'B'-winding of the Reserve Station Service Transformer, RSS2, at Lakeview SS. This work is necessary due to the failure of equipment supplied from this winding.

This work, which is to involve the removal of the bus-links, together with a section of the 4.16kV buswork, is to be completed as soon as possible.

Since the intention of the proposed work is to ensure that the LV connections are permanently isolated, we have concluded that this work will have no adverse impact on the IMO-controlled grid.
[The attached Diagram shows the location of the proposed break.]

The IMO is therefore pleased to grant **conditional approval** for this work, subject to satisfying any requirements for modifying the existing metering arrangement.

Please contact facility.registration@theIMO.com if you have not received a Facility Registration Summary package within the next 10 days.

For further information, please contact the undersigned.

Yours truly,

Bob Gibbons

Manager – Long Term Forecasts & Assessments

Telephone: (905) 855-6482 Fax: (905) 855-6129 E-mail: bob.gibbons@theimo.com

cc: IMO BIRM

Mr Terry Trebilcock, Hydro One Networks Inc.

All information submitted in this process will be used by the IMO solely in support of its obligations under the *Electricity Act, 1998*, the *Ontario Energy Board Act, 1998*, the *Market Rules* and associated policies, standards and procedures and in accordance with its licence. All information submitted will be assigned the appropriate confidentiality level upon receipt.

655 Bay Street, Suite 410, P.O. Box 1, Toronto ON M5G 2K4 Canada tel 905.403.6900 toll free 1.888.448.7777 fax 905.403.6129
www.theIMO.com – helpcentre@theIMO.com

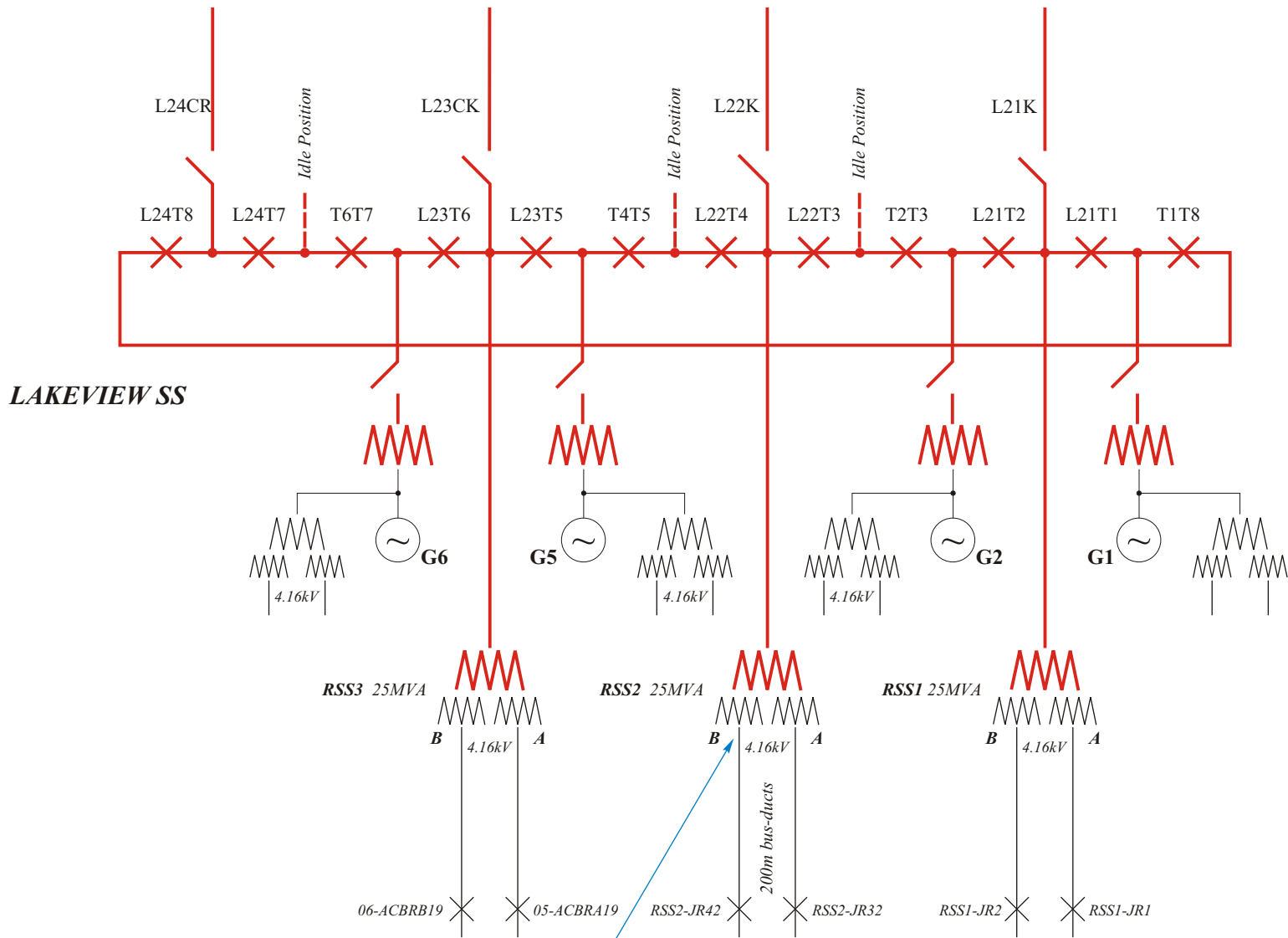

Bus-links and a section of the bus-work to be removed to provide a permanent break in the connection to the 'B' winding

Isolation of the bus-work associated with the B- winding of the Reserve Station Service transformer, RSS2, at Lakeview SS

DIAGRAM 1