



# **CONNECTION ASSESSMENT & APPROVAL PROCESS ASSESSMENT SUMMARY**

**Applicant: Hydro One Networks Inc.**

**Project: St. Marys TS**  
**– Refurbish Station and Increase Capacity**  
**– Add Two 13.8kV Feeder Positions**

**CAA ID: 2002 – EX068 and 2002 – EX088**  
**Long Term Forecasts & Assessments Department**  
**Consistent Information Set Department**

**Date: May 7, 2003**

## 1.0 Description of Proposal

St. Marys TS is a 115-13.8kV station that was built in 1911. The transformer station has had several major revisions and capacity increases over the years. The station presently has two 3-phase, 110-14.2kV±10% 11/15/18MVA transformers (T1 and T2) and three 13.8kV feeder positions. The station is normally connected radially to the Seaforth TS via the 115kV circuit L7S. Switching facilities are available to connect the station to Detweiler TS via 115kV circuit D8S.

Many of the station components have reached the end of their useful life. In addition, the loads supplied by the station have reached its load meeting capability and are forecast to grow by 0.6MW per year. Hydro One Networks Inc., the *Connection Applicant*, is therefore proposing to overhaul St. Marys TS to extend its useful life and to increase its load meeting capability.

The *Connection Applicant* has submitted two Connection Assessment Applications seeking the IMO approvals for:

1. CAA ID 2002 – EX068:  
The refurbishment of St. Marys TS by replacing the existing transformers with higher capacity units and various end-of-life station components.
2. CAA ID 2002 – EX088:  
The addition of two 13.8kV feeder positions to supply expected load growth in the area.

Since both applications involve the same transformer station, the IMO has decided to review both applications under a single assessment.

The refurbishment project at St. Marys TS includes:

- ❖ Replacing the existing 11/15/18MVA transformers T1 and T2 with two new 3-phase 25/33.3/41.7MVA 115.5-14.2±15% kV transformers
- ❖ Replacing the two existing 115kV Mark II circuit switchers 9L7S-71 and 9D8S-8 with two new circuit switchers
- ❖ Replacing the two existing 115kV motorized transformer disconnect switches 9T1-A and 9T2-A
- ❖ Replacing the two 34.5kV 800A circuit breakers T1B and T2Y with two refurbished 2000A oil circuit breakers
- ❖ Replacing the two motorized bus tie switches with manual units and installing a refurbished 34.5kV oil circuit breaker
- ❖ Replacing the existing 15kV 600A feeder breaker M3 with a new vacuum breaker
- ❖ Replacing or refurbishing, as necessary, auxiliary systems including AC and DC station services, protection and control, telecommunications, cabling facilities, grounding system, and lighting system
- ❖ Upgrading any station facilities to accommodate the higher thermal capacity of the new transformers

The station refurbishment work is scheduled to be completed in two stages with transformer T1 and its associated work in July 2003 while T2 and its associated work in December 2003. Figure 1 shows the existing facilities at St. Marys TS and identifies those components that are to be replaced.

The addition of two feeder positions, M4 and M5, will also be completed in two stages. One feeder position will be completed in July 2003, while the second feeder position will be established in the fall of 2003.

Figure 2 shows the facilities at St. Marys TS after the two proposals have been completed.

St. Marys TS – Refurbish Station, Increase Station Capacity and Add Two 13.8kV Feeder Positions

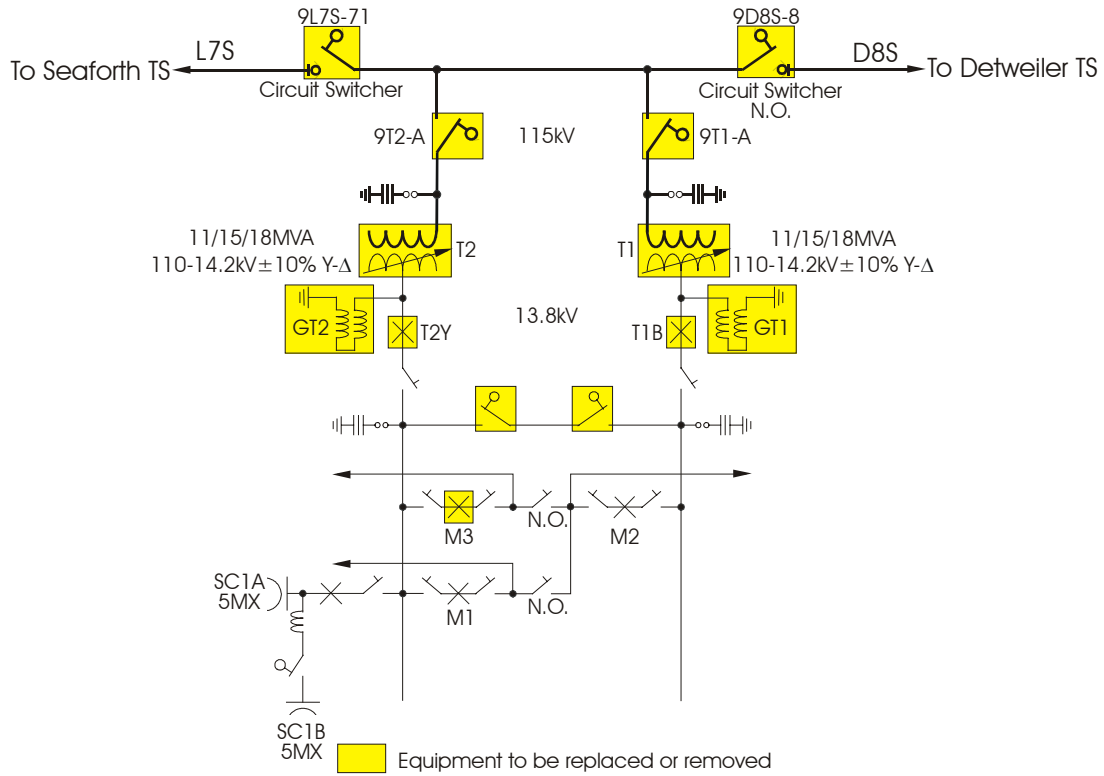

Figure 1: St. Marys TS - Existing Facilities

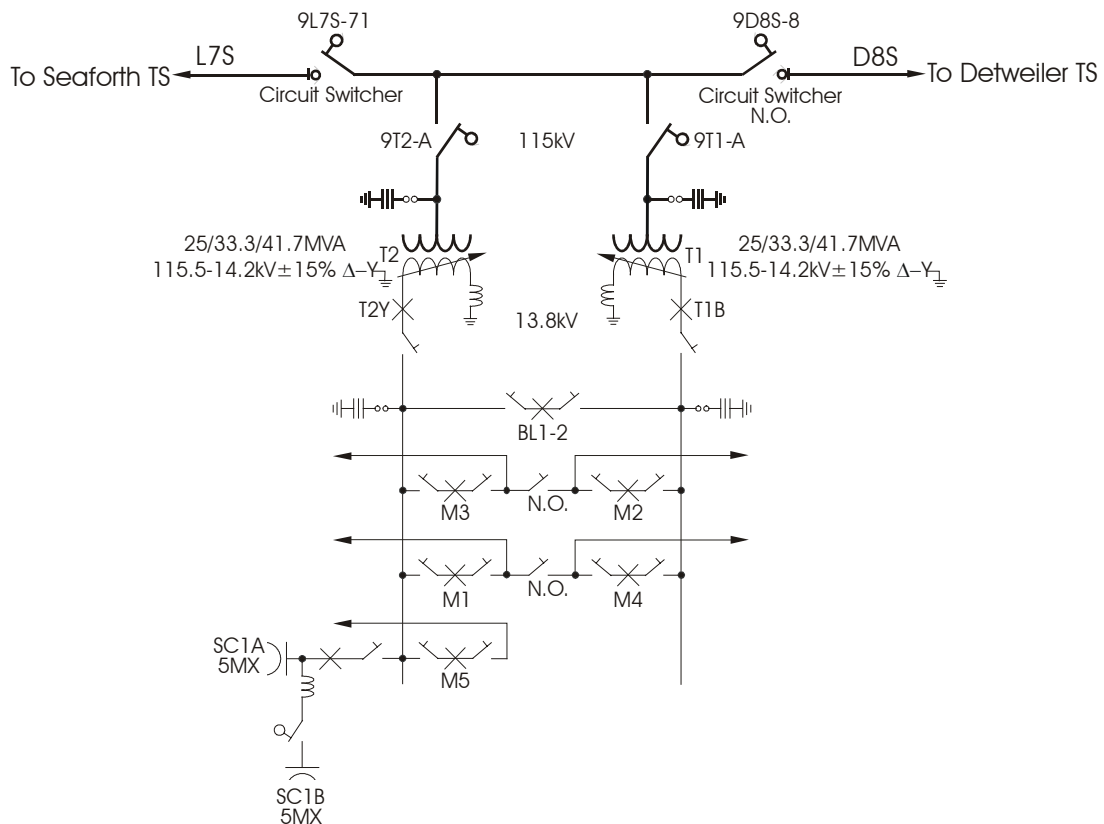

Figure 2: St. Marys TS - With New Facilities

**St. Marys TS – Refurbish Station, Increase Station Capacity and Add Two 13.8kV Feeder Positions**

---

The specifications of new equipment are:

- ❖ Transformers T1 and T2
  - Configuration: 3-Phase
  - Temperature Rise: 65°C
  - Thermal Rating: 25/33.3/41.7MVA
  - Connection: H – Delta; L – Wye grounded via 1.5Ω reactor
  - Rated Voltage: H – 115.5kV; L – 14.2kV
  - Positive Sequence Impedance: 11.5% @ 25MVA and 14.2kV
  - On-load Tap (LV): ± 2.13kV (± 15%) in 24 steps
  
- ❖ Circuit Switchers 9D8S-8 and 9L7S-71
  - Voltage Rating: 138kV
  - Continuous Current Rating: 1200A
  - Momentary Current Rating: 64kA
  
- ❖ Transformer Disconnect Switches 9T1-A and 9T2-A
  - Manufacturer: Alstom
  - Model: CGVB
  - Voltage Rating: 121kV
  - Continuous Current Rating: 1200A
  - Momentary Current Rating: 70kA
  
- ❖ Transformer Oil Circuit Breakers T1B and T2Y (Refurbished Units)
  - Manufacturer: CGE
  - Model: KSO
  - Voltage Rating: 34.5kV
  - Continuous Current Rating: 2000A
  - Short Circuit Rating: 1000MVA Asymmetric
  
- ❖ Bus Tie Oil Circuit Breaker BL1-2 (Refurbished Unit)
  - Manufacturer: Canadian Westinghouse
  - Model: BNOB
  - Voltage Rating: 34.5kV
  - Continuous Current Rating: 2000A
  - Short Circuit Rating: 1000MVA Asymmetric
  
- ❖ Feeder Vacuum Breakers M3, M4, and M5
  - Voltage Rating: 15.5kV
  - Continuous Current Rating: 1200A
  - Short Circuit Rating: 25kA

## 2.0 Assessment

St. Marys TS is radially supplied from Seaforth TS via the 115kV transmission circuit L7S, which also supplies six other stations. In-line switching devices are available at St. Marys TS to transfer the station to circuit D8S from Detweiler TS. Figure 3 shows the supply arrangement of circuits L7S and D8S.

St. Marys TS – Refurbish Station, Increase Station Capacity and Add Two 13.8kV Feeder Positions

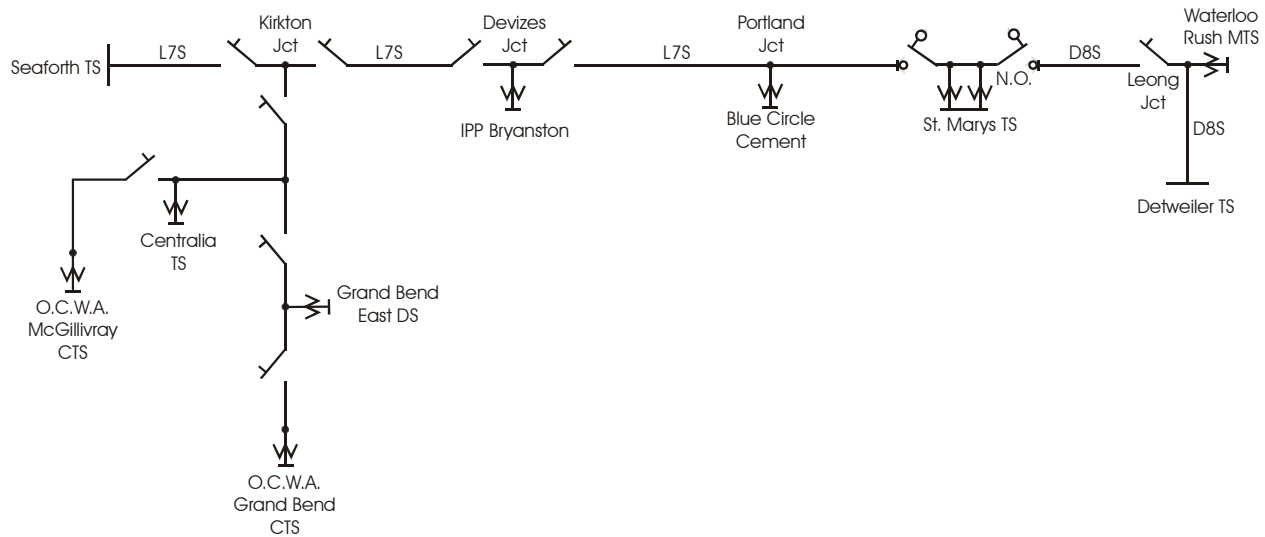

Figure 3: 115kV Circuits L7S and D8S

Many components at St. Marys TS must be replaced or refurbished to maintain the station in-service. In addition, the 2002 summer peak demand of St. Marys TS has exceeded the station load meeting capability. The two proposed projects at St. Marys TS, in addition to extending the useful life of the transformer station, will increase the station capacity to alleviate the overload problem and to supply future load growth in the area. However, increasing the demands at St. Marys TS will impact on the loading of the circuit L7S and voltage profile along the circuit.

The *Connection Applicant* has identified that with higher demands and a critical element out of service, certain stations supplied by circuit L7S could experience voltages below the 113kV level required by the Market Rules. The *Connection Applicant* has therefore installed an additional 10.8MVAR capacitor bank at Centralia TS, which was approved by the IMO under CAA 2002 – EX019, to address the voltage problem in the area.

The following table lists the summer continuous ratings of the circuits L7S and D8S:

L7S Summer Continuous Rating					
From	To	Conductor Size	Max. Op. Temp.	Ampere <sup>1</sup>	MVA <sup>2</sup>
Seaforth TS	Kirkton Jct	477 kcmil	83°C	550	114
Kirkton Jct	Devizes Jct	477 kcmil	95°C	630	131
Devizes Jct	Portland Jct	411.4 kcmil	60°C	370	77
Portland Jct	St Marys TS	477 kcmil	150°C	880	183
D8S Circuit Ampacity					
From	To	Conductor Size	Max. Op. Temp.	Ampere <sup>1</sup>	MVA <sup>2</sup>
Detweiler TS	Leong Jct	477 kcmil	101°C	660	137
Leong Jct	St Marys TS	411.4 kcmil	127°C	700	145
Notes:					
1. Based on 30°C ambient temperature and 4km/h wind					
2. Based on 120kV					

**St. Marys TS – Refurbish Station, Increase Station Capacity and Add Two 13.8kV Feeder Positions**

---

Circuit L7S supplies seven stations and the maximum circuit loading occurs on the section between the Seaforth TS to Kirkton Junction section. The total 2002 summer peak demand of the seven stations supplied from L7S was about 108MVA, which is about 95% of the summer continuous rating of the Seaforth to Kirkton Junction section. The loads supplied by circuit L7S are forecast to grow at an average annual rate of 1.33%. Circuit L7S could therefore be overloaded within five years.

Circuit D8S from Detweiler TS presently supplies about 50% of the Waterloo Rush MTS, which is also connected to circuit D10H from Detweiler. The loading on D8S is about 20MVA and with a summer continuous rating of 137MVA the circuit can easily take on additional loads. In addition, the *Connection Applicant* has recently applied and received approval from the IMO under CAA 2003 – EX124 to increase the station capacity at Detweiler TS.

If and when circuit L7S becomes overloaded, St. Marys TS can be transferred to circuit D8S via the in-line circuit switchers at the station and be normally supplied from Detweiler TS.

It is therefore concluded that the two proposed projects at St. Marys TS would not have any adverse impact on the IMO-controlled grid.

### **3.0 Notification of Approval**

Based on the above assessment, it is recommended that a Notification of Approval for the two proposals be issued to the *Connection Applicant*.