



May 4, 2006

Mr. Naren Pattani  
Manager, Transmission System Development  
Investment Planning Division  
Hydro One  
483 Bay Street  
Toronto, Ontario, M5G 2P5

Dear Mr. Pattani:

**L25N & L27N In-line Breakers**  
***Notification of Conditional Approval***  
**CAA ID Number: 2005-EX261**

Thank you for the information on the plan for installing two new in-line breakers on 230 kV circuits L25N and L27N at the Petrosar Junction. The System Impact Assessment report together with the new equipment specifications is attached.

The IESO has determined that the proposed in-line breakers will not have a material adverse effect on the reliability of the IESO-controlled grid.

Subject to your signed acknowledgment below, the IESO is pleased to grant **conditional approval** for the proposed modifications, subject to the implementation of the requirements detailed in the attached assessment report. Any material changes to your proposal may require re-assessment by the IESO in accordance with Market Manual 2.10, and may nullify your conditional approval.

**Final approval** will be granted upon successful completion of the IESO Market Entry process. During this process you will be expected to demonstrate that you have fulfilled the requirements and the modification is at least as good as the proposal assessed by the IESO. Please contact [market.entry@ieso.ca](mailto:market.entry@ieso.ca) if you have not received a Facility Registration Summary package within the next 10 days.

For further information, please contact the undersigned.

Yours truly,

Michael Falvo  
Manager – Transmission Assessments & Performance  
Telephone: (:905) 855-6209  
Fax: (905) 403-6932  
E-mail: [mike.falvo@ieso.ca](mailto:mike.falvo@ieso.ca)  
cc: IESO Records

---

All information submitted in this process will be used by the IMO solely in support of its obligations under the *Electricity Act, 1998*, the *Ontario Energy Board Act, 1998*, the *Market Rules* and associated policies, standards and procedures and in accordance with its licence. All information submitted will be assigned the appropriate confidentiality level upon receipt.

---

Hydro One acknowledges receipt of the System Impact Assessment Report setting out the IESO requirements for final approval, and commits to fulfill these requirements, and all other applicable Market Rules, before receiving final approval to connect to the IESO-controlled grid.

Dated: May 04, 2006

Per: N. Pattani

Name: N. PATTANI

Title: Manager, Transmission System Development

---

**Expedited System Impact Assessment  
Hydro One Networks Inc.  
230 kV Circuits L25N and L27N – Addition of In-line Breakers at Petrosar Junction  
CAA ID Number: 2005-EX261**

### ***1.0 Project Description***

Hydro One proposes to add an in-line breaker and associated equipment ('A' & 'B' protections, breaker disconnects, HV arresters, CVTs and coupling capacitors) to each 230 kV circuit L25N and L27N, between the Lambton switching station (SS) and Sarnia-Scott transformer station (TS).

The above facilities are to be installed at new station called Nova Chemical switching station (SS). The station will be located on the existing L25N/L27N transmission right-of-way, affecting two line spans at the Petrosar Junction, where the Nova Corunna tap (tower #40) is located.

As shown in Diagram 1, one breaker is to be connected to the south of the Nova Corunna tap location on circuit L25N and the other breaker is to be connected to the north of the Nova Corunna tap location on circuit L27N.

The purpose of the in-line breakers is to improve the supply reliability of L25N/L27N transmission connected customer Nova Corunna by reducing the likelihood of supply interruptions due to double circuit line outages.

The scheduled in-service date of this project is June 2007.

It should be noted that the work for this project will be coordinated with Hydro One work related to the connection of the Greenfield Energy Centre (CAA ID 2004-167) and St. Clair Energy Centre (CAA ID 2004-187). The specific Hydro One work required for the connection of Greenfield and St Clair is detailed in the SIA report IESO\_REP\_0292, found on the IESO web site at [http://www.ieso.ca/imoweb/connAssess/caa\\_StatusSummary.asp](http://www.ieso.ca/imoweb/connAssess/caa_StatusSummary.asp).

Diagram 2 is a single line diagram of the 500 kV and 230 kV power systems in southwest Ontario. In particular, the diagram shows the proposed locations of the Greenfield and St. Clair Energy Centres relative to the proposed location of Nova Chemical SS, and the locations of the various transmission customers connected to 230 kV circuits L23N, L25N and L27N, between Lambton SS and Sarnia-Scott TS.

### ***2.0 Equipment Specifications***

The in-line breaker specifications provided by Hydro One are:

- Type – SF6
- Continuous maximum operating voltage – 250 kV
- Rated interrupting time – 3 cycles (50 ms)
- Continuous current rating – 3,000 A
- Short circuit symmetrical duty – 63 kA

The motorized breaker disconnect specifications are:

- Type – Disconnect
  - Continuous maximum operating voltage – 250 kV
  - Continuous current rating – 2,000 A
-

The specified equipment meets the Market Rules and the Transmission System Code requirements for rated symmetrical short circuit duty, rated interrupting time and continuous maximum operating voltage.

#### *Equipment (including Breakers & Disconnects)*

All equipment ratings must be capable of continuously operating in the range of 59.5 Hz to 60.5 Hz (Reference 1 of Appendix 4.1 of the Market Rules).

All 230 kV equipment must be capable of continuously operating in the range of 220 kV to 250 kV (Reference 2 of Appendix 4.1 of the Market Rules). More specifically, this means:

- equipment must have a maximum continuous voltage rating of at least 250 kV in southern Ontario,
- equipment must be able to interrupt fault current for voltages up to the maximum continuous rating, and
- equipment must remain in service, and not automatically trip, for voltages up to 5% above the maximum continuous rating, for up to 30 minutes, to allow the system to be re-dispatched to return voltages within their normal range.

#### *IESO Monitoring and Telemetry Data*

The Market Rules (Appendices 4.16, 4.20 and 4.21) list the requirements with respect to telemetry data that must be provided to the IESO and to the performance standards that must be achieved on a continual basis by transmitters. The IESO requires the status of the in-line breakers be telemetered to the IESO.

#### *Auto-reclosure*

Hydro One also must install auto-reclosure facilities including under-voltage plus time, voltage presence plus time and synchrocheck capabilities for the in-line breakers.

### **3.0 Assessment**

#### *Effect on Supply Reliability to Transmission Customers Nova Corunna & Nova Moore*

The installation of in-line breakers and associated equipment near the Nova Corunna tap will split each existing 230 kV circuit L25N and L27N into two sections – one section from Petrosar Junction to Sarnia-Scott TS and the other section from Petrosar Junction to Lambton SS.

New protections will be installed at the Petrosar Junction and coordinated with the existing L25N and L27N protections at Lambton SS and Sarnia-Scott TS so that only faulted circuit sections are removed from service and non-faulted circuit sections remain in service.

Specifically, the following post-contingency connection conditions are expected to occur for Nova Corunna:

- For a double circuit line outage on the Petrosar Junction to Sarnia-Scott TS section, Nova Corunna will remain connected on the L27N Petrosar Junction to Lambton SS circuit section;
-

- For a double circuit line outage on the Petrosar Junction to Lambton SS section, Nova Corunna will remain connected on the L25N Petrosar Junction to Sarnia-Scott TS circuit section.

This will minimize the exposure of Nova Corunna to a supply interruption due to a double circuit line outage. The IESO, therefore, finds the installation of in-line breakers at Petrosar Junction will improve the supply reliability to Nova Corunna.

It should be noted that the supply reliability of Nova Moore will also be marginally improved. A double circuit line outage on the Petrosar Junction to Sarnia-Scott TS section will leave Nova Moore connected on the L25N and L27N Petrosar Junction to Lambton SS circuit sections.

#### *Effect on the proposed St. Clair Energy Centre*

As detailed in SIA Report IESO\_REP\_0292, the St. Clair Energy Centre is a 638 MW combined cycle generation facility that plans to connect to 230 kV circuits L25N and L27N by the third quarter of 2007 or the first quarter of 2008. Subsequent to the issue of the SIA Report, St. Clair Power LP has identified a new site for the St. Clair Energy Centre and a resulting new connection point to the IESO-controlled grid. The new site is approximately 3 km northeast of the original site.

With the addition of the in-line breakers, the St. Clair Energy Centre will be connected on the L25N and L27N circuit sections from Petrosar Junction to Sarnia-Scott TS.

For similar reasons previously described for Nova Moore, the ability of St. Clair to remain connected to the IESO-controlled grid will be marginally improved with the addition of the in-line breakers by minimizing the exposure of double circuit line outages.

#### *Sarnia-Scott and Lambton Generation Rejection (G/R) Schemes*

As detailed in SIA report IESO\_REP\_0292, the existing Sarnia-Scott G/R Scheme must be modified and a new Lambton G/R Scheme must be built by Hydro One to allow the connection of the Greenfield and St. Clair Energy Centres. With the addition of the in-line breakers and the new proposed St. Clair connection point, an additional functionality is required in the Sarnia-Scott Scheme to reject the St. Clair Energy Centre for the following outage conditions:

- For a planned Sarnia-Scott terminal outage of L25N and the loss of the L25N Petrosar Junction to Lambton SS circuit section, the L25N Petrosar Junction to Sarnia-Scott TS circuit section becomes isolated, and
- For a planned Sarnia-Scott terminal outage of L27N and the loss of the L27N Petrosar Junction to Lambton SS circuit section, the L27N Petrosar Junction to Sarnia-Scott TS circuit section becomes isolated.

In either case, a dispatched St. Clair Energy Centre remains connected to the isolated circuit section, thereby, causing St. Clair generation to loop through the LV buses of the transmission customers connected to the Petrosar Junction to Sarnia-Scott circuit sections.

The resulting loop flow at these customer facilities could exceed the thermal capability of the connected equipment. Therefore, the capability to reject St. Clair for these conditions is required in the Sarnia-Scott G/R Scheme.

Transmission customer Nova Corunna would be affected by the St. Clair generation for the aforementioned outages involving L25N, while transmission customers Nova St. Clair and Shell Canada would be affected for the outages involving L27N.

To provide maximum operating flexibility, the capability to reject Imperial Oil, TransAlta Sarnia and Greenfield for outages involving the new in-line breakers is also required in the Sarnia-Scott G/R Scheme.

Diagrams 3 and 4 provide the overall functional specifications required for the existing Sarnia-Scott G/R Scheme and the new Lambton G/R Scheme, respectively, to incorporate the Greenfield and St. Clair Energy Centres. With the incorporation of the L25N and L27N in-line breakers, Hydro One must modify the Sarnia-Scott G/R Scheme to monitor for open conditions of these new breakers and to enable the pre-arming and tripping of Imperial Oil, TransAlta Sarnia, St. Clair and/or Greenfield, before the Greenfield Energy Centre or the St. Clair Energy Centre connect.

Hydro One must also provide a Functional Description Document (FDD) to the IESO that describes the modified Sarnia Scott G/R Scheme in sufficient detail for the IESO to demonstrate to Northeast Power Coordinating Council (NPCC) that the modifications will not have a material adverse effect on reliability. The FDD must be available at least six months before the scheduled in-service date of either the Greenfield Energy Centre or the St. Clair Energy Centre.

#### ***4.0 Summary of IESO Requirements***

Hydro One is required to:

- Install equipment ratings capable of continuously operating in the range of 59.5 Hz to 60.5 Hz.
  - Install 230 kV equipment capable of continuously operating in the range of 220 kV to 250 kV. More specifically, this means:
    1. equipment must have a maximum continuous voltage rating of at least 250 kV in southern Ontario,
    2. equipment must be able to interrupt fault current for voltages up to the maximum continuous rating, and
    3. equipment must remain in service, and not automatically trip, for voltages up to 5% above the maximum continuous rating, for up to 30 minutes, to allow the system to be re-dispatched to return voltages within their normal range.
  - Provide telemetry status of the in-line breakers in accordance with the Market Rules performance standards.
  - Install auto-reclosure facilities including under-voltage plus time, voltage presence plus time and synchrocheck capabilities for the in-line breakers.
  - Modify the existing Sarnia-Scott G/R Scheme for the capability to pre-arm and trip Imperial Oil, TransAlta Sarnia, St. Clair and/or Greenfield generation for breaker open conditions associated with the in-line breakers before the Greenfield Energy Centre or the St. Clair Energy Centre connect.
  - Provide a Functional Description Document (FDD) to the IESO that describes the modified Sarnia Scott G/R Scheme in sufficient detail for the IESO to demonstrate to Northeast Power Coordinating Council (NPCC) that the modifications will not have a material adverse effect on
-

reliability. The FDD must be available at least six months before the scheduled in-service date of either the Greenfield Energy Centre or the St. Clair Energy Centre.

## **5.0 Conclusions**

This expedited System Impact Assessment concludes that the installation of in-line breakers on 230 kV circuits L25N and L27N is not expected to have a material adverse effect on the IESO-controlled grid. It is therefore recommended that a Notification of Conditional Approval of the Connection Proposal be issued.

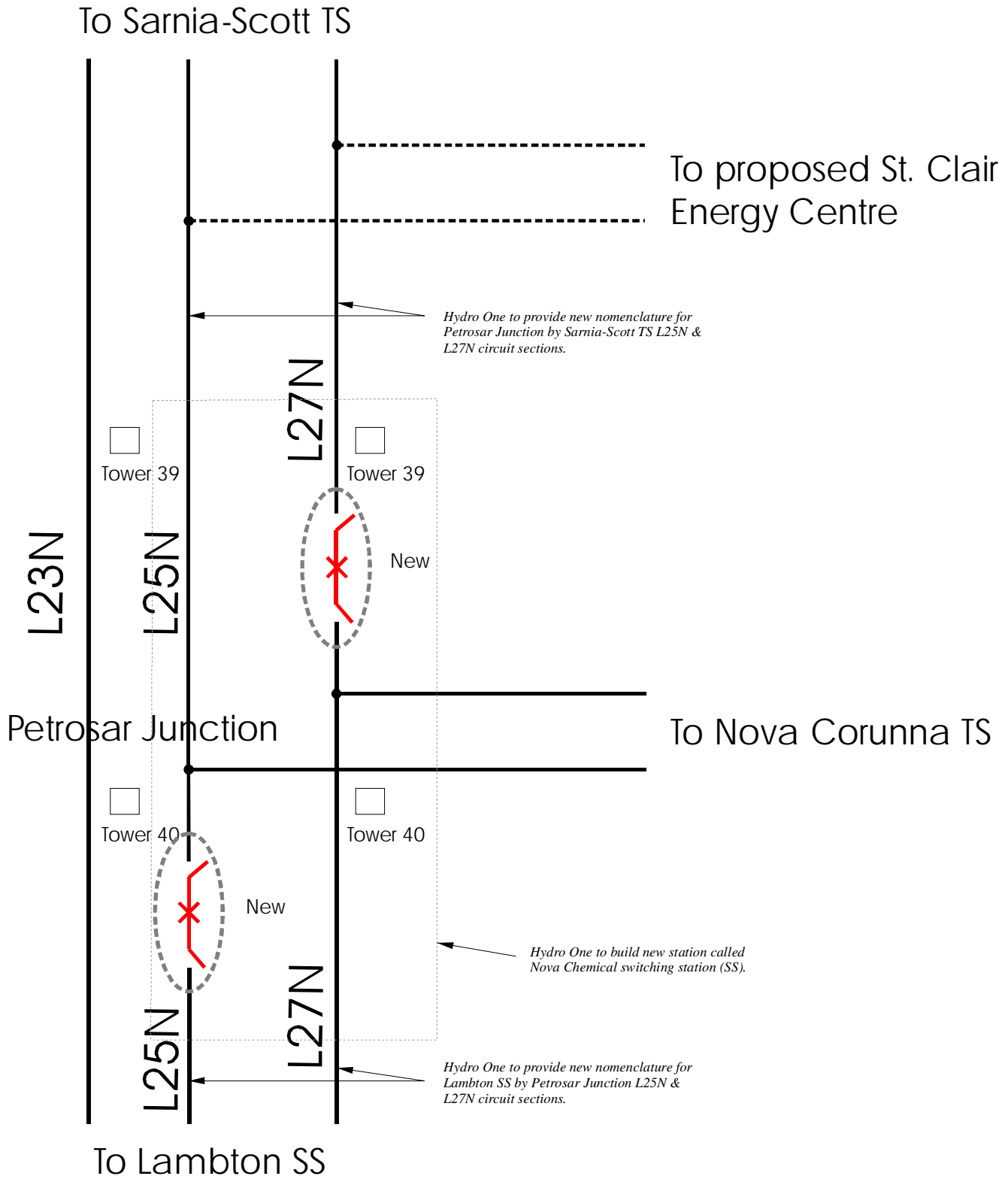
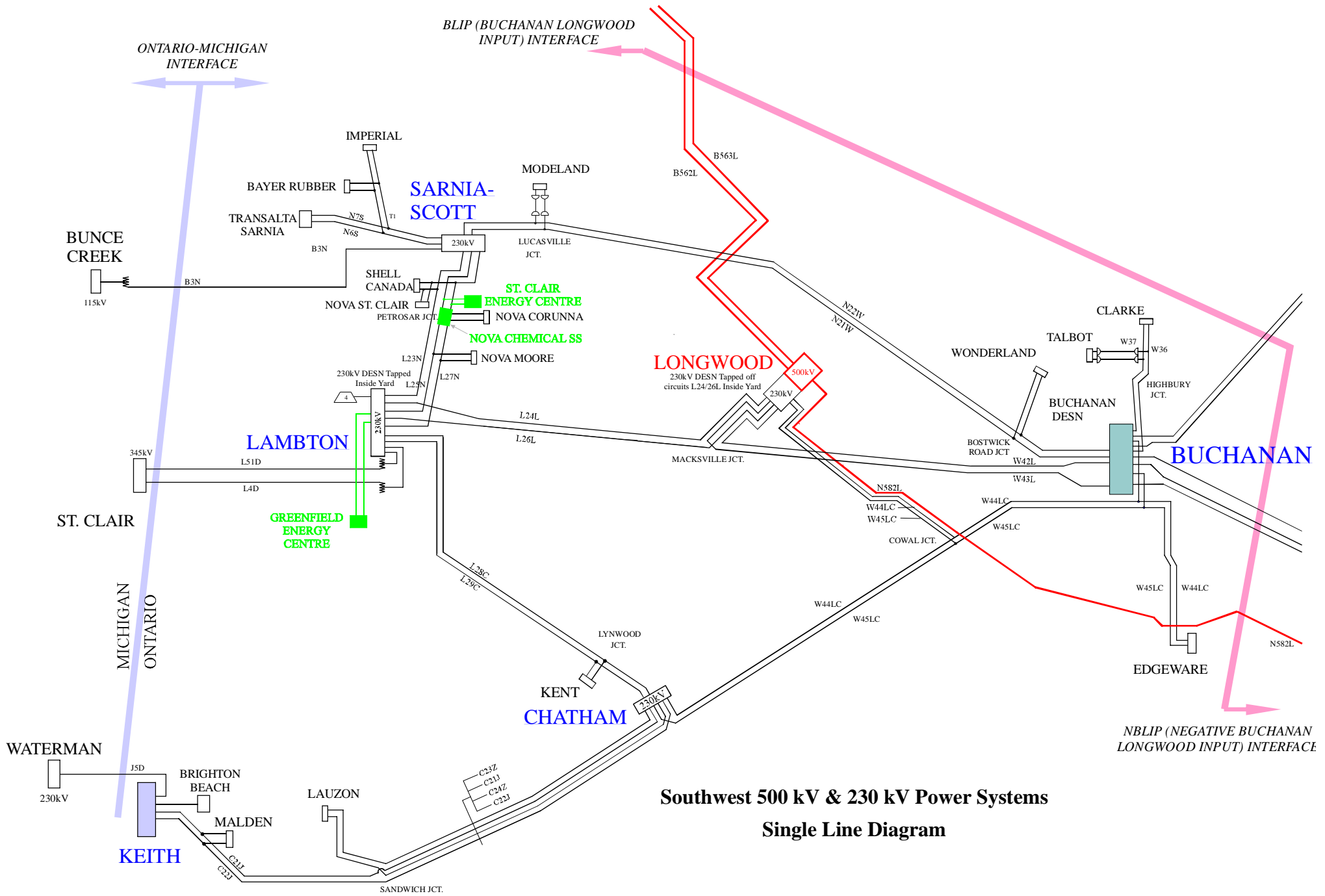



Diagram 1 - Proposed L25N & L27N In-line Breakers





**DIAGRAM 2**



XYZ Status of individual breakers, derived from breaker pallet switches and the breaker trip module [OR gate]

 Selection Contact for G/R, armed via SCADA

 Transmitter }  
 Receiver } Transceiver

\* Denotes Lambton SS terminal

## Functional Specification for the Lambton G/R Scheme

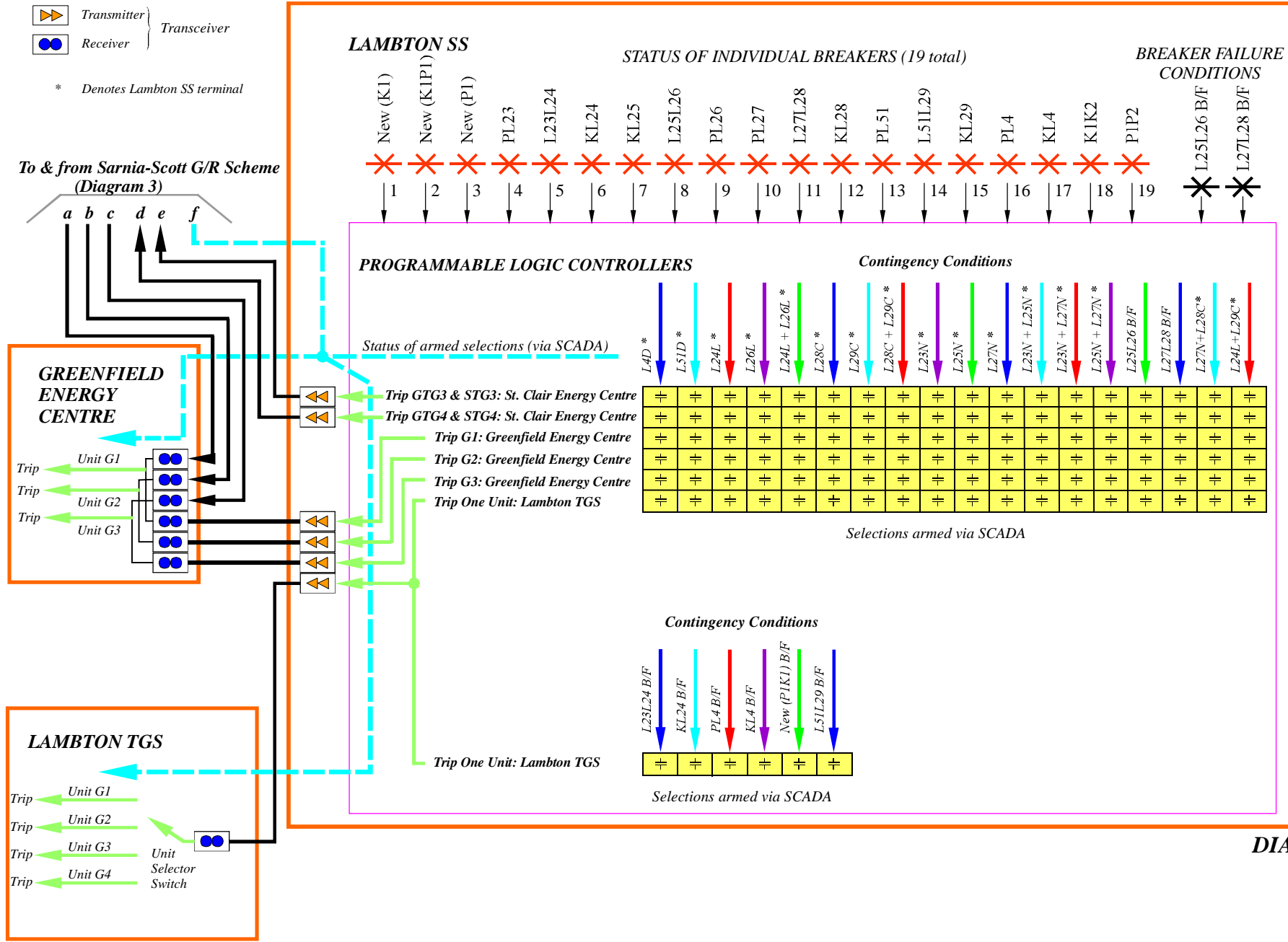

DIAGRAM 4