



REPORT

System Impact Assessment Report - Greenfield & St. Clair Energy Centres

**Connection Assessment &
Approval Process**

Issue 1.0

Greenfield Energy Centre CAA ID 2004-167
Applicant: Greenfield Energy Centre LP.

St. Clair Energy Centre CAA ID 2004-187
Applicant: St. Clair Power LP.

Transmission Assessments & Performance
Department

December 6, 2005

| | |
|-------------------------|---|
| Document ID | IESO_REP_0292 |
| Document Name | System Impact Assessment Report - Greenfield & St. Clair Energy Centres |
| Issue | Issue 1.0 |
| Reason for Issue | First Issue |
| Effective Date | December 6, 2005 |

Greenfield & St. Clair Energy Centres

Acknowledgement

The IESO wished to acknowledge the assistance of Hydro One in completing this assessment.

Disclaimers

IESO

This Report has been prepared solely for the purpose of assessing whether the connection applicant's proposed connection with the IESO-controlled grid would have an adverse impact on the reliability of the integrated power system and whether the IESO should issue a notice of conditional approval or disapproval of the proposed connection under Chapter 4, section 6 of the Market Rules.

Conditional approval of the proposed connection is based on information provided to the IESO by the connection applicant and Hydro One at the time the assessment was carried out. The IESO assumes no responsibility for the accuracy or completeness of such information, including the results of studies carried out by Hydro One at the request of the IESO. Furthermore, the conditional approval is subject to further consideration due to changes to this information, or to additional information that may become available after the conditional approval has been granted.

If the connection applicant has engaged a consultant to perform connection assessment studies, the connection applicant acknowledges that the IESO will be relying on such studies in conducting its assessment and that the IESO assumes no responsibility for the accuracy or completeness of such studies including, without limitation, any changes to IESO base case models made by the consultant. The IESO reserves the right to repeat any or all connection studies performed by the consultant if necessary to meet IESO requirements.

Conditional approval of the proposed connection means that there are no significant reliability issues or concerns that would prevent connection of the proposed facility to the IESO-controlled grid. However, the conditional approval does not ensure that a project will meet all connection requirements. In addition, further issues or concerns may be identified by the transmitter(s) during the detailed design phase that may require changes to equipment characteristics and/or configuration to ensure compliance with physical or equipment limitations, or with the Transmission System Code, before connection can be made.

This Report has not been prepared for any other purpose and should not be used or relied upon by any person for another purpose. This Report has been prepared solely for use by the connection applicant and the IESO in accordance with Chapter 4, section 6 of the Market Rules. The IESO assumes no responsibility to any third party for any use, which it makes of this Report. Any liability which the IESO may have to the connection applicant in respect of this Report is governed by Chapter 1, section 13 of the Market Rules. In the event that the IESO provides a draft of this Report to the connection applicant, the connection applicant must be aware that the IESO may revise drafts of this Report at any time in its sole discretion without notice to the connection applicant. Although the IESO will use its best efforts to advise you of any such changes, it is the responsibility of the connection applicant to ensure that the most recent version of this Report is being used.

Hydro One

The results reported in this Report are based on the information available to Hydro One, at the time of the study, suitable for a preliminary assessment of this transmission system reinforcement proposal.

The short circuit and thermal loading levels have been computed based on the information available at the time of the study. These levels may be higher or lower if the connection information changes as a result of, but not limited to, subsequent design modifications or when more accurate test measurement data is available.

This study does not assess the short circuit or thermal loading impact of the proposed facilities on load and generation customers.

In this Report, short circuit adequacy is assessed only for Hydro One breakers. The short circuit results are only for the purpose of assessing the capabilities of existing Hydro One breakers and identifying upgrades required to incorporate the proposed facilities. These results should not be used in the design and engineering of any new or existing facilities. The necessary data will be provided by Hydro One and discussed with any connection proponent upon request.

The ampacity ratings of Hydro One facilities are established based on assumptions used in Hydro One for power system planning studies. The actual ampacity ratings during operations may be determined in real-time and are based on actual system conditions, including ambient temperature, wind speed and facility loading, and may be higher or lower than those stated in this study.

The additional facilities or upgrades which are required to incorporate the proposed facilities have been identified to the extent permitted by a preliminary assessment under the current IESO Connection Assessment and Approval process. Additional facility studies may be necessary to confirm constructability and the time required for construction. Further studies at more advanced stages of the project development may identify additional facilities that need to be provided or that require upgrading.

Summary

The connection of the Greenfield Energy Centre (Greenfield) 1,147 MW combined cycle generation facility, and the St. Clair Energy Centre (St. Clair) 638 MW combined cycle facility in the vicinity of Lambton Switching Station (SS) and Sarnia-Scott Transformer Station (TS), subject to the requirements stated in this Report, is expected to have no material adverse effect on the reliability of the IESO-controlled grid.

Provided the generator's facilities are designed and constructed to satisfy the Ontario Electricity Market Rules (Market Rules) requirements for generators and transmitters, including the requirements specified in this Report, and provided the generation facilities are connected as described in this Report and the network enhancements are implemented as specified in this Report, the Greenfield and St. Clair facilities will be approved to connect to the IESO-controlled grid and allowed to participate in the IESO-administered market.

Greenfield is proposing a new 1,147 MW combined cycle generation facility in St. Clair Township. The plant, consisting of three natural gas-fired units of 210 MW each, and one steam turbine generator of 517 MW, is to be connected via a 3.5 km 230 kV double circuit line to the Lambton SS.

St. Clair is proposing a new 638 MW combined cycle facility in St. Clair Township. This plant, consisting of two gas-fired units of 185 MW each, and two steam turbine generators of 134 MW each, is to be connected via 230 kV line taps to the existing Nova Corunna taps on Lambton to Sarnia-Scott circuits L25N and L27N.

These two plants have signed contracts to supply capacity and energy as part of the Ontario Government's 2,500 MW new clean generation and demand-side RFP.

This assessment finds that the following network additions and modifications are required in and around Hydro One's Lambton and Sarnia-Scott switchyards to satisfy IESO reliability standards and to allow the simultaneous operation of Greenfield, St. Clair, and four Lambton TGS units:

- add a new 230 kV diameter with three new breakers installed in the Lambton SS north switchyard to connect Greenfield,
- replace Lambton SS 230 kV breakers KL29, L51L29 and PL51 with higher thermally rated breakers,
- operate the Lambton SS 230 kV bus 'split', to mitigate fault levels in excess of the breaker interrupting capability, whenever there are two or more Lambton units operating simultaneously with Greenfield and St. Clair,
- re-terminate certain existing circuits in the Lambton SS, and install new Generation Rejection (G/R) tripping system at Lambton SS and modify existing G/R tripping system at Sarnia-Scott TS to include Greenfield and St. Clair in these G/R systems so as to preserve the existing transfer capability into and out of Lambton SS,
- increase the thermal ratings of the existing Nova Corunna L25N and L27N 230 kV taps from tower #2 to Petrosar Junction,
- replace Sarnia-Scott TS 230 kV breakers AL21, L21L27, L6L23 and L7L22 with breakers having a higher fault interrupting capability, to allow the operation of more than two Lambton units simultaneously with Greenfield and St. Clair, and

- operate the St. Clair bus-tie breaker T3T4 normally open, whenever the Lambton SS 230 kV bus is operated 'split'.

The proposed connection arrangements for Greenfield and St. Clair are acceptable to the IESO subject to the specific IESO requirements identified below. The reconfiguration of Lambton SS is also adequate to support the long term operation of the Lambton 'scrubber' equipped units G3 and G4 should they not be phased out after the in service dates of Greenfield and St. Clair.

The transformers and generator characteristics specified for both Greenfield and St. Clair will be adequate to allow the units to supply their full active power and the required full reactive power range within $\pm 5\%$ of their rated terminal voltage for at least one constant 230 kV system voltage.

The proposed design of the two 230 kV Greenfield by Lambton transmission circuits to allow full plant output on one circuit does not require any additional network additions or modifications to the items already prescribed above.

The generator excitation system characteristics for the Greenfield generators and the St. Clair gas-fired turbine generators satisfy the Market Rules requirements. For the St. Clair steam turbine generators, the static exciter type option satisfies the Market Rules requirements, but the brushless exciter type option does not.

The voltage performance of the power system in the Lambton area with Greenfield and St. Clair operating as proposed is expected to be acceptable in both the pre-contingency and post-contingency states. Transient stability studies show that the Greenfield and St. Clair generating units remain stable for all examined fault conditions with acceptable damping for St. Clair and poor damping for Greenfield.

Conclusions and IESO Requirements

Notification of Approval

It is recommended that a *Notification of Conditional Approval for Connection* be issued for each of Greenfield Energy Centre and St. Clair Energy Centre subject to the IESO receiving from each proponent written acknowledgement that the requirements described below under the heading “IESO Requirements” will be implemented.

The connection of the Greenfield Energy Centre (Greenfield) 1,147 MW combined cycle generation facility, and the St. Clair Energy Centre (St. Clair) 638 MW combined cycle facility in the vicinity of Lambton SS and Sarnia-Scott TS, subject to the requirements stated in this Report, is expected to have no material adverse effect on the reliability of the IESO-controlled grid.

IESO Requirements

Provided the generator’s facilities are designed and constructed to satisfy the Market Rule requirements for generators and transmitters, including the requirements specified in this Report, and provided the generation facilities are connected as described in this Report and the network enhancements are implemented as specified in this Report, the Greenfield and St. Clair facilities will be approved to connect to the IESO-controlled grid and allowed to participate in the IESO-administered market.

Final connection of these projects may also be subject to additional requirements specified in the Customer Impact Assessment performed by Hydro One.

The IESO requires the following enhancements and requirements to connect Greenfield and St. Clair:

Greenfield & St. Clair

1. All generators must satisfy the Generator Facility requirements in Appendix 4.2, References 1 to 16, of the Market Rules
2. All connection equipment ratings must be capable of continuously operating in the range of 59.5 Hz to 60.5 Hz (Reference 1 of Appendix 4.1 of the Market Rules).

All 230 kV connection equipment must have a rated symmetrical short circuit capability of at least 63 kA, and all 230 kV breakers must have a rated interrupting time of three cycles (50 ms) or less (OEB Transmission System Code).

All 230 kV connection equipment must be capable of continuously operating in the range 220 kV and 250 kV (Reference 2 of Appendix 4.1 of the Market Rules).

More specifically, this means:

- connection equipment must have a maximum continuous voltage rating of at least 250 kV in southern Ontario,
- equipment must be able to interrupt fault current for voltages up to the maximum continuous rating, and

- equipment must remain in service, and not automatically trip, for voltages up to 5% above the maximum continuous rating, for up to 30 minutes, to allow the system to be re-dispatched to return voltages within their normal range.
3. Plant auxiliaries at Greenfield and St. Clair are required to operate continuously over the entire voltage range of 220 kV to 250 kV.
 4. Synchronizing breakers at Greenfield and St. Clair must be capable of withstanding at least a 2 pu voltage across their open terminals.
 5. Greenfield and St. Clair must complete the IESO Facility Registration process in a timely manner before IESO final approval for connection is granted. Finalized models and data, including any controls that would be operational, must be provided to the IESO. This information should be submitted to the IESO at least seven months before first synchronization of any unit to allow the IESO to perform any additional reliability studies.
 6. During commissioning, Greenfield and St. Clair are required to provide evidence that confirms the equipment installed matches or exceeds the performance predicted in the finalized models and data. This evidence shall be either type tests done in a controlled environment or commissioning tests done on-site. In either case, the testing must be done not only in accordance with widely recognized standards, but also to the satisfaction of the IESO. Until this evidence is provided, Greenfield and St. Clair must accept any restrictions the IESO may impose upon their participation in IESO-administered market or connection to the IESO-controlled grid.
 7. Each proponent, Greenfield and St. Clair, for its respective facilities, must satisfy the Transmission System Code technical requirements and/or any requirements identified by Hydro One for protection and telecommunication facilities. Where required by Hydro One, the Greenfield and St. Clair protection systems must be coordinated with Hydro One protections systems.

Special protection system facilities at Greenfield and St. Clair must also comply with the Northeast Power Coordinating Council (NPCC) Special Protection System Criteria (Document A-11) for type 1 special protection systems.

More specifically, this means protection and special protection systems associated with each facility must be fully duplicated and supplied from separate batteries.

8. For under-frequency system conditions the Greenfield and St. Clair generators must not trip for frequency variations that are below 60 Hz but above the curve in Figure 1 of this Report.
9. The Greenfield and St. Clair generators should trip only as required for contingencies within the generator zone of protection and not trip for faults outside of the generator zone of protection.
10. The design of the protection and control facilities at Greenfield and St. Clair must not preclude the installation of auto-reclosure facilities in the future should system requirements change.

Greenfield

1. At a minimum, Greenfield 230 kV breakers P1J1, J1J2, Q1J3, P1H1, H2H3 and Q1H3 must be capable for synchronizing duty.

2. Telemetry data and associated communication facilities for Greenfield must comply with Appendices 4.15 and 4.19 of the Market Rules, in accordance with a major generation facility.

At a minimum, the following items must be telemetered to the IESO from the facility:

- Four quadrant, net 230 kV active and reactive power flows on both 230 kV transmission circuits connecting to Lambton SS
 - 230 kV voltages associated with both transmission circuits connecting to Lambton SS
 - Status of 230 kV line disconnect J3-L1 & H1-L2
 - Status of all eight 230 kV breakers
 - Generators G1, G2, G3 & G4 active and reactive power
3. Greenfield must submit four separate offers to the IESO-administered market, one for each generator injection point. The IESO recognizes that this may lead to a dispatch that results in an inefficient operation of the Greenfield generators and will investigate with Greenfield the possible use of other offer arrangements to minimize this possibility.
 4. Greenfield must install special protection facilities to accept Generation Rejection (G/R) signals from the new Lambton G/R Scheme and the existing Sarnia-Scott G/R Scheme, and trip gas-fired generators G1, G2 and G3 individually, any pair or all three when pre-armed.
 5. During commissioning, Greenfield must appropriately tune the exciters and stabilizers to provide better damping than the damping predicted in section 12 'Assessment of Transient Stability' of this Report.

St. Clair

1. Telemetry data and associated communication facilities for St. Clair must comply with Appendices 4.15 and 4.19 of the Market Rules, in accordance with a major generation facility.

At a minimum, the following items must be telemetered to the IESO from the facility:

- Four quadrant, net 230 kV active and reactive power flows on both 230 kV transmission taps connecting to the Nova Corunna 230 kV taps
 - 230 kV voltages associated with both transmission taps connecting to the Nova Corunna 230 kV taps
 - Status of 230 kV line disconnects L27N-T4L27 & L25N-T3L25
 - Status of 230 kV breakers T4L27, T3T4 & T3L25
 - Generators GTG4, STG4, GTG3 & STG3 active and reactive power
2. Since there is a potential for the facility to inject at two separate points, St. Clair must submit separate offers to the IESO-administered market for each of these injection points.
 3. St. Clair must install special protection facilities to accept Generation Rejection (G/R) signals from the new Lambton G/R Scheme and the existing Sarnia-Scott G/R Scheme, and trip coupled generators GTG3 & STG3, GTG4 & STG4 or both when pre-armed.
 4. St. Clair must install the static exciter type option for steam turbine generators STG3 and STG4 to satisfy the requirements of Reference 12, Appendix 4.2 of the Market Rules.

Hydro One

1. To connect Greenfield at Lambton SS, Hydro One must install a new 230 kV diameter with three new breakers P1, K1P1 and K1 rated at least 3,000 A in the north switchyard as shown in Diagram 4 of this Report. The three new breakers also must have auto-reclosure facilities including under-voltage plus time and synchrocheck capabilities.

Hydro One also must replace Lambton SS 230 kV breakers KL29, L51L29 and PL51 with higher rated units of least 3,000 A.

The new equipment must also comply with the requirements identified in item 2 of the 'Greenfield & St. Clair' sub-section of this section.

2. To allow a 'split' operation of the Lambton SS 230 kV bus (breakers K1K2 and P1P2 open), Hydro One must connect the new Greenfield circuits and re-terminate some existing circuits at Lambton SS according to the diameter arrangements shown in Diagram 7 of this Report. Specifically, the following work is required:
 - connect Greenfield (G1 & G4) to the new diameter in the position by the K1 bus,
 - re-terminate circuit L24L to the new diameter in the position by the P2 bus,
 - re-terminate circuit L51D to the vacated L24L position,
 - connect Greenfield (G2 & G3) to the vacated L51D position, and
 - interchange circuits L26L and L29C positions.
3. To connect St. Clair, Hydro One must improve the continuous rating and 15-Minute LTR of the existing Nova Corunna L25N and L27N 230 kV taps from tower #2 to Petrosar Junction.
4. To allow for the possible dispatch of more than two Lambton TGS units with Greenfield and St. Clair in service, Hydro One must replace the existing Sarnia-Scott TS 230 kV breakers AL21, L21L27, L6L23 and L7L22 with new breakers having rated fault interrupting capabilities of 63 kA.

The new breakers must also comply with the requirements identified in item 2 of the 'Greenfield & St. Clair' sub-section of this section.

5. Hydro One must install a new connectivity-based G/R Scheme at Lambton SS and modify the existing Sarnia-Scott G/R Scheme to allow the G/R tripping of both Greenfield and St. Clair according to the functional specification shown in Diagram 8 of this Report.

In addition, the existing Sarnia-Scott G/R Scheme must be modified to monitor contingencies associated with a Sarnia-Scott TS L21L27 breaker-fail condition and a Buchanan TS L22L44 breaker-fail condition.

The new Lambton G/R Scheme must also comply with the Northeast Power Coordinating Council (NPCC) Special Protection System Criteria (Document A-11) for type 1 special protection systems.

6. Hydro One is expected to examine the effect that the increased fault levels may have on the remaining station equipment (buswork, disconnect switches, etc.) at Lambton SS and Sarnia-Scott TS, and make any required enhancements to the equipment. This examination should be based on the expected worst cases for fault levels.

Table of Contents

| | |
|--|------------|
| Table of Contents | i |
| List of Figures | iii |
| List of Tables | iv |
| List of Diagrams | vi |
| 1. Introduction | 1 |
| 2. Summary of Individual Projects | 3 |
| 3. Connection Arrangement of Individual Projects | 5 |
| 3.1 Greenfield Energy Centre..... | 5 |
| 3.2 St. Clair Energy Centre..... | 6 |
| 4. General Requirements | 9 |
| 5. Requirements to Connect Greenfield & St. Clair | 15 |
| 6. Assessment of Fault Levels | 17 |
| 7. Assessment of Transfer Capability | 23 |
| 8. Assessment of Fault Levels with Lambton ‘Split’ & Reconfigured (Lambton 230 kV bus Open) | 27 |
| 9. Assessment of a Greenfield x Lambton 230 kV Transmission Circuit Outage | 31 |
| 10. Special Protection Systems | 33 |
| 11. Assessment of Voltage Performance | 37 |
| 12. Assessment of Transient Stability | 41 |
| 12.1 Excitation System Performance..... | 41 |
| 12.1.1 Greenfield..... | 41 |
| 12.1.2 St. Clair | 46 |
| 12.2 Transient Stability Results | 53 |
| Appendix A: Results of Voltage Performance Studies | A-1 |

Appendix B: Results of Transient Stability StudiesB-1

List of Figures

Figure 1: Standards for Setting Under-frequency Trip Protection for Generators..... 11

Figure 2: Greenfield – Gas-Fired Turbine Generator Open-Circuit Response 43

Figure 3: Greenfield – Steam Turbine Generator Open-Circuit Response..... 43

Figure 4: St. Clair – Gas-Fired Turbine Generator Open-Circuit Response 49

Figure 5: St. Clair – Steam Turbine Generator with Exciter Option A Open-Circuit Response
..... 50

Figure 6: St. Clair – Steam Turbine Generator with Exciter Option B Open-Circuit Response
..... 51

List of Tables

| | |
|---|----|
| Table 1: Fault Levels on the Lambton 230 kV bus for a pre-fault voltage of 250 kV (Greenfield 230 kV bus open & St. Clair 230 kV bus closed) | 17 |
| Table 2: Fault Levels on the Sarnia-Scott 230 kV bus for a pre-fault voltage of 250 kV (Lambton 230 kV bus closed, Greenfield 230 kV bus open & St. Clair 230 kV bus closed)..... | 19 |
| Table 3: Fault Duty on Sarnia-Scott ‘A’ rated 230 kV breakers with Greenfield, St. Clair & four Lambton units in service & Lambton 230 kV bus closed | 19 |
| Table 4: Fault Duty on Sarnia-Scott ‘A’ rated 230 kV breakers with Greenfield, St. Clair & Lambton units G3 & G4 in service & Lambton 230 kV bus closed..... | 20 |
| Table 5: Fault Duty on Sarnia-Scott ‘A’ rated 230 kV breakers with Greenfield, St. Clair & zero Lambton units in service & Lambton 230 kV bus closed | 20 |
| Table 6: Fault Levels on the Sarnia-Scott 115 kV bus for a pre-fault voltage of 127 kV (Lambton 230 kV bus closed, Greenfield 230 kV bus open & St. Clair 230 kV bus closed)..... | 21 |
| Table 7: ‘Lambton Input’ & ‘Sarnia Output’ Transfer Capabilities | 25 |
| Table 8: Fault Levels with Lambton 230 kV bus ‘split’ & reconfigured with Greenfield, St. Clair, and 4 Lambton units in service (Greenfield & St. Clair 230 kV buses open) | 27 |
| Table 9: Fault Levels with Lambton 230 kV bus ‘split’ & reconfigured with Greenfield, St. Clair and Lambton units G3 & G4 in service (Greenfield & St. Clair 230 kV buses open) | 27 |
| Table 10: Fault Duty on Sarnia-Scott ‘A’ rated 230 kV breakers with Greenfield, St. Clair & four Lambton units in service & Lambton 230 kV bus ‘split’..... | 28 |
| Table 11: Fault Duty on Sarnia-Scott ‘A’ rated 230 kV breakers with Greenfield, St. Clair & Lambton units G3 & G4 in service & Lambton 230 kV bus ‘split’ | 28 |
| Table 12: Change in Fault Levels – Existing Lambton 230 kV Bus Closed to Lambton 230 kV Bus ‘Split’ & Reconfigured | 29 |
| Table 13: Voltage Performance – Greenfield Case Studies | 37 |
| Table 14: Voltage Performance – St. Clair Case Studies | 38 |
| Table 15: Voltage Performance – Contingency Condition and associated Voltage Decline Criterion..... | 38 |
| Table 16: Greenfield – Generator Parameters | 41 |
| Table 17: Greenfield – ESST1A Data for Gas-fired Turbine Generators and Steam Turbine Generator | 42 |
| Table 18: Greenfield – PSS2A Data for Gas-Fired Turbine Generators/PSS1A Data for Steam Turbine Generator | 44 |
| Table 19: Greenfield – WESGOV Data for Gas-Fired Turbine Generators G1, G2, & G3 ... | 45 |
| Table 20: Greenfield – IEESGO Data for Steam Turbine Generator G4..... | 45 |
| Table 21: St. Clair – Generator Parameters | 46 |
| Table 22: St. Clair – ESST4B Data for Gas-fired Turbine Generators GTG3 & GTG4..... | 46 |

| | |
|--|----|
| Table 23: St. Clair – ESAC2A Data for Steam Turbine Generators STG3 & STG4 – Option A | 47 |
| Table 24: St. Clair – ESST4B Data for Steam Turbine Generators STG3 & STG4 – Option B | 48 |
| Table 25: St. Clair – PSS2A Data for Gas-Fired Turbine Generators and Steam Turbine Generators..... | 52 |
| Table 26: St. Clair – GAST Data for Gas-Fired Turbine Generators GTG3 & GTG4..... | 52 |
| Table 27: St. Clair – IEESGO Data for Steam Turbine Generators STG3 & STG4..... | 53 |

List of Diagrams

| | |
|---|----|
| Diagram 1: Greenfield Energy Centre – 230 kV Single Line Diagram..... | 55 |
| Diagram 2: St. Clair Energy Centre – 230 kV Single Line Diagram..... | 56 |
| Diagram 3: Lambton SS – Existing – 230 kV Single Line Diagram..... | 57 |
| Diagram 4: Lambton SS – New Diameter & Breakers – 230 kV Single Line Diagram..... | 58 |
| Diagram 5: Sarnia-Scott TS – 230 kV & 115 kV Single Line Diagram..... | 59 |
| Diagram 6: Study Interfaces ‘Lambton Input’ & ‘Sarnia Output’..... | 60 |
| Diagram 7: Lambton SS – ‘Split’ (Breakers K1K2 & P1P2 Open) & Reconfigured – 230 kV Single Line Diagram..... | 61 |
| Diagram 8: Functional Specification for the Lambton & Sarnia-Scott G/R Schemes..... | 62 |

1. Introduction

This Report documents the IESO assessment of the adequacy of the proposed connection arrangements, compares the performance characteristics of the generator and associated equipment against the Market Rules standards, analyzes the adequacy of the short circuit and thermal capability of the local transmission system, and assesses the voltage and stability performance of the IESO-controlled grid with the new facilities connected. This Report provides the generator proponents and the transmitter a list of the changes and enhancements to the proposals to ensure that the new facilities, when connected, will not have a material adverse effect on the reliability of the IESO-controlled grid. The Report also points out significant Market Rules requirements for generators that are commonly misunderstood or missed in the proposals.

This System Impact Assessment has been conducted to examine the effect of the Greenfield Energy Centre (Greenfield) 1,147 MW generation facility and the St. Clair Energy Centre (St. Clair) 638 MW generation facility on the reliability of the IESO-controlled grid.

Both Greenfield and St. Clair were selected by the Ontario Government as part of the 2,500 MW new clean generation and demand-side RFP.

Commissioning of Greenfield is scheduled to commence in the second quarter of 2007, while commissioning St. Clair is scheduled to commence in the third quarter of 2007. Commercial operation of Greenfield and St. Clair is to commence in either the fourth quarter of 2007 or the first quarter of 2008.

– End of Section –

2. Summary of Individual Projects

The Greenfield Energy Centre (Greenfield) is to be a new 1,147 MW combined cycle generation facility in St. Clair Township and is to be located near the Lambton Thermal Generating Station (TGS). The Greenfield facility will consist of three natural gas-fired turbine generators G1, G2, and G3 with a maximum rated capacity of 210 MW each, and one steam turbine generator G4 with a maximum rated capacity of 517 MW. The facility will be connected via a new 230 kV double circuit line (3.5 km long) to the Hydro One Networks Inc. (Hydro One) owned 230 kV switchyard at Lambton TGS, called the Lambton Switching Station (SS). Diagram 1 is a 230 kV single line diagram of Greenfield.

The St. Clair Energy Centre (St. Clair) is to be a new 638 MW combined cycle facility in St. Clair Township, consisting of two gas-fired turbine generators GTG3 and GTG4 with a maximum rated capacity of 185 MW each, and two steam turbine generators STG3 and STG4 with a maximum rated capacity of 134 MW each. The facility will be connected via new 230 kV taps to tower #2 of the existing Nova Corunna taps associated with circuits L25N and L27N between Lambton SS and Sarnia-Scott Transformer Station (TS). Diagram 2 is a 230 kV single line diagram of St. Clair.

Under the Ontario Government's 2,500 MW new clean generation and demand-side RFP, the contract capacity for Greenfield is 1,005 MW and the contract capacity for St. Clair is 570 MW.

– End of Section –

3. Connection Arrangement of Individual Projects

3.1 Greenfield Energy Centre

Connection Arrangement

As shown in Diagram 1, the proposed Greenfield facility is to employ a 230 kV ring bus configuration with eight buses. A total of eight 230 kV breakers rated at 3,000 A are to be used in this configuration with breakers P1J1 and Q1H3 to be operated normally open.

Each generator is to be terminated to a separate bus on the 230 kV ring bus via a two winding generator step-up transformer. Four of eight buses are to be used for this purpose.

Of the four remaining buses, two buses are to be used to connect the facility via two new 230 kV transmission circuits to Lambton SS, and two buses are to be used to provide station service to the facility.

Due to the ring bus configuration, various synchronizing arrangements could be employed. It is recognized that all eight 230 kV breakers could be used for synchronizing duty.

At a minimum, Greenfield 230 kV breakers P1J1, J1J2, Q1J3, P1H1, H2H3 and Q1H3 must be capable for synchronizing duty.

The 242/18 kV generator step-up transformers T1, T2, and T3 are to be rated 150/200/250 MVA and connected HV-wye grounded/LV-delta. Fixed off-load HV taps at 0, $\pm 2.5\%$, $\pm 5\%$ are to be provided. The 242/18 kV generator step-up transformer T4 is to be rated 360/480/600 MVA and connected HV-wye grounded/LV-delta. Transformer T4 will also be equipped with fixed off-load HV taps at 0, $\pm 2.5\%$, $\pm 5\%$.

The new 230 kV transmission circuits between the Greenfield generation facility and Lambton SS will be adequately sized by Greenfield to allow the full plant output to flow on one circuit should the companion circuit be unavailable.

The 230 kV circuits will also be strung on a common set of towers along a route approximately 3.5 km long. The loss of a tower will result in a complete disconnection of Greenfield.

The IESO also understands that Greenfield is not designed to operate with the steam turbine generator G4 off line for long periods of time. On loss of G4, Greenfield has indicated that the gas-fired turbine generators (GTGs) G1, G2 and G3 would runback and eventually shutdown. This could represent a total generation loss of 1,005 MW or more if all generators are in service. Currently, the largest generation loss used in determining the Ontario generation reserve requirements is a Darlington generating unit at approximately 900 MW. Depending on Greenfield's output, the runback of GTGs due to a steam turbine generator contingency may represent the largest generation loss to be respected in determining reserve requirements. To address this concern, Greenfield has indicated that the

facility could be controlled on runback to maintain an output of 200 MW with one or more of the GTGs in simple cycle mode for a period of up to four hours if required.

The proposed Greenfield connection arrangement is acceptable to the IESO.

Electricity Market Offers

The Ontario Electricity Market structure for determining the dispatch of generation facilities requires separate offers to be submitted for each injection point.

Due to the 230 kV ring bus configuration of the Greenfield facility, there will be four generator injection points to the IESO-controlled grid. A separate offer must then be submitted to the IESO-administered market for each injection point. However, given the three gas turbine to one steam turbine combined cycle design of the facility, the IESO recognizes that this may lead to a dispatch that results in an inefficient operation of the generators. The IESO will investigate with Greenfield the possible use of other offer arrangements to minimize this possibility.

3.2 St. Clair Energy Centre

Connection Arrangement

As shown in Diagram 2, the proposed St. Clair facility is to employ a configuration using two 230 kV buses tied together via a 230 kV bus-tie breaker. Each bus then connects to the IESO-controlled grid via a separate 230 kV breaker and a short tap. In this configuration, a total of three 230 kV breakers rated at 2,500 A are to be used. As a starting point for the SIA studies, bus-tie breaker T3T4 was assumed to be operated normally closed.

Each coupled pair of generators, one gas-fired turbine generator (GTG) and one steam turbine generator (STG), connects to a 230 kV bus via a three winding generator step-up transformer. A low-voltage synchronizing breaker is to be provided for each generator.

The 238/13.8/18 kV generator step-up transformers T3 and T4 are to be rated 222/296/370 MVA and connected HV-wye grounded/LV-delta-delta. Fixed off-load HV taps at 0, $\pm 2.5\%$, $\pm 5\%$ are to be provided.

GTGs GTG3 and GTG4 will connect to the T3 and T4 'Y' windings, and STGs STG3 and STG4 will connect to the T3 and T4 'X' windings, respectively.

High resistance grounding is also provided through a distribution transformer in each of the generator neutrals.

The proposed St. Clair connection arrangement is acceptable to the IESO.

Electricity Market Offers

The Ontario Electricity Market structure for determining the dispatch of generation facilities requires separate offers to be submitted for each injection point.

Since there is a potential for St. Clair to inject at two separate points, separate offers must be submitted to the IESO-administered market for each of these injection points.

– End of Section –

4. General Requirements

Models & Data

Greenfield and St. Clair must complete the IESO Facility Registration process in a timely manner before IESO final approval for connection is granted. Finalized models and data, including any controls that would be operational, must be provided to the IESO. This information should be submitted to the IESO at least seven months before first synchronization of any unit to allow the IESO to perform any additional reliability studies.

During commissioning, Greenfield and St. Clair are required to provide evidence that confirms the equipment installed matches or exceeds the performance predicted in the finalized models and data. This evidence shall be either type tests done in a controlled environment or commissioning tests done on-site. In either case, the testing must be done not only in accordance with widely recognized standards, but also to the satisfaction of the IESO. Until this evidence is provided, Greenfield and St. Clair must accept any restrictions the IESO may impose upon their participation in IESO-administered market or connection to the IESO-controlled grid.

Generators

All generators must satisfy the Generator Facility requirements in Appendix 4.2, References 1 to 16, of the Market Rules.

References 1 and 2 require that a generator connecting to the IESO-controlled grid must, at a minimum, have the capability to perform the following:

- Supply full active power continuously to the IESO-controlled grid while operating at a generator terminal voltage ranging from 0.95 pu to 1.05 pu of the generator's rated terminal voltage, and
- Supply full active power and be able to provide reactive power in the range of 0.9 lagging to 0.95 leading power factor at its generator terminals for at least one constant 230 kV system voltage.

The above two requirements would effectively limit the impedance between the generator terminals and HV side of the 230 kV generator step-up transformers to a maximum of 0.13 pu based on the MVA rating of the generator(s), which is normally based on the maximum continuous active power rating at a 0.9 power factor. However, if a generator is capable of supplying the full reactive power range at its terminals for at least one constant system voltage while operating at a terminal voltage range greater than 0.95 pu to 1.05 pu, the effective maximum impedance allowed between the generator terminals and the HV side of the generator step-up transformer could be higher than 0.13 pu.

The following transformer impedances have been provided by Greenfield and St. Clair:

- Greenfield T1, T2, & T3 – 8% on 150 MVA_{transformer base}
- Greenfield T4 – 7.3% on 360 MVA_{transformer base}

- St. Clair T3 & T4 – X winding, 7.4% on 93 MVA_{transformer base} & Y winding, 7.4% on 129 MVA_{transformer base}

Converting the transformer impedances from the transformer base to the rated MVA generator base results in the following impedances:

- Greenfield T1, T2, T3 – 12.44% on 233 MVA_{generator base}
- Greenfield T4 – 11.64% on 574 MVA_{generator base}
- St. Clair T3 & T4 – X winding, 11.85% on 148.89 MVA_{generator base}
- St. Clair T3 & T4 – Y winding, 10.32% on 180 MVA_{generator base (summer)}
- St. Clair T3 & T4 – Y winding, 11.79% on 205.56 MVA_{generator base (winter)}

Based on the provided transformer and generator characteristics for Greenfield and St. Clair, the Greenfield and St. Clair generators would be able to supply full active power and the required full reactive power range within $\pm 5\%$ of its rated terminal voltage for at least one constant 230 kV system voltage.

Connection Equipment (Breakers, Disconnects, Transformers, Buses)

To comply with Reference 1 of Appendix 4.1 of the Market Rules, connection equipment must be capable of continuously operating in the range between 59.5 Hz and 60.5 Hz.

The Transmission System Code also requires that 230 kV equipment have a rated symmetrical short circuit capability of at least 63 kA and that 230 kV breakers have a rated interrupting time of three cycles (50ms) or less.

To comply with Reference 2 of Appendix 4.1 of the Market Rules, all 230 kV connection equipment must be capable of continuously operating in the range between 220 kV and 250 kV.

Some recognized contingencies (e.g. load shedding, open line end) can cause a temporary voltage increase above the maximum continuous of 250 kV. For these conditions, connection equipment may be exposed to voltages slightly above its maximum continuous rating for the short period of time that it takes the IESO to direct operations to restore a normal voltage profile, and to prepare for the next contingency. This re-preparation period will be as short as possible, but it will not take longer than 30 minutes.

Therefore, the IESO requires that the 230 kV connection equipment have the following requirements:

- connection equipment must have a maximum continuous voltage rating of at least 250 kV in southern Ontario,
- equipment must be able to interrupt fault current for voltages up to the maximum continuous rating, and
- equipment must remain in service, and not automatically trip, for voltages up to 5% above the maximum continuous rating, for up to 30 minutes, to allow the system to be re-dispatched to return voltages within their normal range.

Plant auxiliaries are required to operate continuously over the entire range of transmission voltages 220 kV to 250 kV.

Synchronizing breakers must be capable of withstanding at least a 2 pu voltage across their open terminals.

Protection Systems

Each proponent, Greenfield and St. Clair, for its respective facilities, must satisfy the Transmission System Code technical requirements and/or any requirements identified by Hydro One for protection and telecommunication facilities. Where required by Hydro One, the Greenfield and St. Clair protection systems must be coordinated with Hydro One protections systems.

Special protection system facilities at Greenfield and St. Clair must also comply with the Northeast Power Coordinating Council (NPCC) Special Protection System Criteria (Document A-11) for type 1 special protection systems.

More specifically, this means protection and special protection systems associated with each facility must be fully duplicated and supplied from separate batteries.

Reference #3 of Appendix 4.2 of the Market Rules requires that generating facilities be capable of operating continuously at full power for a system frequency range between 59.4 Hz to 60.6 Hz.

For under frequency system conditions the generators shall not trip for frequency variations that are below 60 Hz but above the curve shown in Figure 1 below.

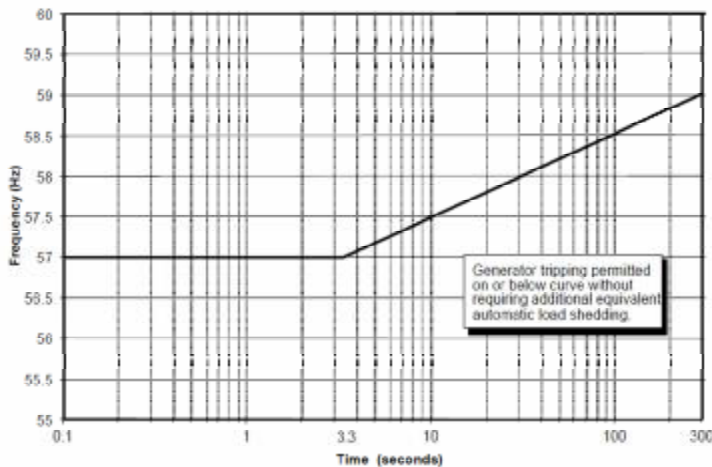

Figure 1: Standards for Setting Under-frequency Trip Protection for Generators

The above criterion is required to ensure the maintenance of the stability of an island, if formed, and to avoid major under-frequency load shedding in the area.

Generators should trip only as required for contingencies within the generator zone of protection and not trip for faults outside of the generator zone of protection.

IESO Monitoring and Telemetry Data

The Market Rules (Appendix 4.15 and Appendix 4.19) list the requirements with respect to telemetry data must be provided to the IESO and to the performance standards that must be achieved on a continual basis by all generators.

In accordance with the requirements for a *major generation facility*, Greenfield and St. Clair must ensure that all the equipment needed to provide the telemetry data and meet the performance standards will be installed.

The IESO requires the minimum following items to be telemetered to the IESO from the Greenfield facility:

- Four quadrant, net 230 kV active and reactive power flows on both 230 kV transmission circuits connecting to Lambton SS
- 230 kV voltages associated with both transmission circuits connecting to Lambton SS
- Status of 230 kV line disconnect J3-L1 & H1-L2
- Status of all eight 230 kV breakers
- Generators G1, G2, G3 & G4 active and reactive power

The IESO requires the minimum following items to be telemetered to the IESO from the St. Clair facility:

- Four quadrant, net 230 kV active and reactive power flows on both 230 kV transmission taps connecting to the Nova Corunna 230 kV taps
- 230 kV voltages associated with both transmission taps connecting to the Nova Corunna 230 kV taps
- Status of 230 kV line disconnects L27N-T4L27 & L25N-T3L25
- Status of 230 kV breakers T4L27, T3T4 & T3L25
- Generators GTG4, STG4, GTG3 & STG3 active and reactive power

The IESO will finalize items to be telemetered during the IESO Facility Registration Process.

Auto-reclosure

Auto-reclosure of the Greenfield 230 kV breakers associated with the new Greenfield x Lambton transmission circuits is not recommended if generation is still connected at Greenfield. Therefore, auto-reclosure facilities on the Greenfield 230 kV breakers J2J3, Q1J3, P1H1 and H1H2 are not required.

Likewise, auto-reclosure of St. Clair 230 kV breakers T3L25 or T4L27 for a L25N or L27N contingency, respectively, is not recommended if generation is still connected at St. Clair. Therefore, auto-reclosure facilities on the St. Clair 230 kV breakers T3L25 and T4L27 are not required.

| |
|---|
| However, the design of the protection and control facilities at Greenfield and St. Clair must not preclude the installation of auto-reclosure facilities in the future should system requirements change. |
|---|

– End of Section –

5. Requirements to Connect Greenfield & St. Clair

Greenfield at Lambton SS

Diagram 3 is a 230 kV single line diagram showing the existing arrangement at Lambton SS. It is provided for reference purposes.

For reasons detailed in section 6 ‘Assessment of Fault Levels’, a ‘split’ operation of the Lambton 230 kV bus (breakers K1K2 and P1P2 open) is required for certain generator dispatches in the Lambton area. To facilitate this mode of operation, a north and south switchyard connection of Greenfield is required. Specifically, generators G1 and G4 shall be connected to the north switchyard and generators G2 and G3 shall be connected to the south switchyard.

To connect Greenfield at Lambton SS, Hydro One must install a new 230 kV diameter with three new breakers in the north switchyard and replace existing breakers KL29, L51L29 and PL51 in the south switchyard with higher thermally rated units. Diagram 4 shows the addition of the new diameter and breakers P1, K1P1 and K1 in north switchyard.

For the three new breakers P1, K1P1 and K1, Hydro One also must install auto-reclosure facilities including under-voltage plus time and synchrocheck capabilities.

The need to add the new diameter in the north switchyard and the specific diameter connections required for Greenfield in the Lambton north and south switchyards are detailed in the section 7 ‘Assessment of Transfer Capability’. The need to replace breakers KL29, L51L29 and PL51 in the south switchyard is discussed in section 9 ‘Assessment of a Greenfield x Lambton 230 kV Transmission Circuit Outage’.

St. Clair at the Nova Corunna L25N & L27N 230 kV taps

Historically, the Nova Corunna peak load is approximately 30 MVA. The summer continuous rating and 15-Minute Limited Time Rating (LTR) of both the L25N and L27N 230 kV taps to Nova Corunna are approximately 500 MVA (35°C, 5 km/h) and 575 MVA (35°C, 5 km/h, 75% preload), respectively, under a conservative system voltage assumption of 235 kV. Under outage conditions to circuit L25N or L27N, the westward power flow on the remaining tap would exceed its 15-Minute LTR with St. Clair at full output (660 MVA) and Nova Corunna at peak load. For Nova Corunna loads less than peak, the westward power flow would be higher.

To connect St. Clair, Hydro One must improve the continuous rating and 15-Minute LTR of the existing Nova Corunna L25N and L27N 230 kV taps from tower #2 to Petrosar Junction.

Greenfield & St. Clair in the Lambton Area

The connection of Greenfield and St. Clair in the Lambton area must also allow for the following transition activities defined in the Coal Replacement Plan:

- allow Lambton TGS to remain operational for an overlap period of at least three months to during the commissioning of Greenfield and St. Clair, and
- allow Lambton TGS to remain on reserve (and operate when called upon) for a period of at least nine months after the commercial in-service dates of Greenfield and St. Clair.

Further details on the Coal Replacement Plan can be found in the IESO 10-Year Outlook 2006-2015. This Outlook is located at IESO web page

http://www.ieso.ca/imoweb/pubs/marketReports/10YearOutlook_2005jul.pdf

Therefore, the incorporation of Greenfield and St. Clair must allow for the simultaneous dispatch of Greenfield, St. Clair and all four Lambton TGS units.

– End of Section –

6. Assessment of Fault Levels

Hydro One fault level studies, September 2005, indicated that the 3-phase and line-to-ground (L-G) fault levels at Lambton SS and Sarnia-Scott TS would exceed the interrupting capability of some existing circuit breakers at these locations for certain generator dispatches in the Lambton area involving Greenfield, St. Clair and Lambton TGS.

For Lambton TGS, the following specific generator dispatches were assumed in the studies:

- All four units G1, G2, G3 & G4,
- Two units G3 & G4, and
- Zero units.

Units G3 and G4 are equipped with flue gas desulphurization units, commonly known as ‘scrubbers’, which minimizes the amount of sulphur dioxide entering the atmosphere. As such, the IESO assumed for the SIA studies that the dispatch of two Lambton units would be limited to these units.

The fault level studies also assumed all transmission elements were in service.

Lambton SS - 230 kV bus closed

Table 1: Fault Levels on the Lambton 230 kV bus for a pre-fault voltage of 250 kV (Greenfield 230 kV bus open & St. Clair 230 kV bus closed)

| | Symmetrical Fault (kA) | | Asymmetrical Fault (kA) | | Breaker Capabilities (kA) @ 250 kV | | | |
|---|------------------------|--------------|-------------------------|--------------|------------------------------------|-------------|--------------|-------------|
| | 3-phase | L-G | 3-phase | L-G | Symmetrical | | Asymmetrical | |
| Existing with 0 Lambton units | 41.16 | 37.10 | 50.63 | 39.76 | A | 65.0 | A | 78.0 |
| | | | | | B | 70.0 | B | 92.0 |
| Existing with 4 Lambton units | 56.77 | 62.62 | 71.56 | 79.63 | A | 65.0 | A | 78.0 |
| | | | | | B | 70.0 | B | 92.0 |
| Existing with Greenfield, St. Clair & 4 Lambton units | 72.07 | 80.85 | 92.09 | 98.30 | A | 65.0 | A | 78.0 |
| | | | | | B | 70.0 | B | 92.0 |
| Existing with Greenfield, St. Clair & Lambton G3 & G4 units | 64.26 | 69.59 | 81.61 | 80.98 | A | 65.0 | A | 78.0 |
| | | | | | B | 70.0 | B | 92.0 |
| Existing with Greenfield, St. Clair & 0 Lambton units | 56.47 | 57.30 | 71.15 | 61.05 | A | 65.0 | A | 78.0 |
| | | | | | B | 70.0 | B | 92.0 |

Note: The ‘A’ rating applies to breakers PL4 & KL4; the ‘B’ rating to remaining 230 kV breakers at Lambton SS.

The high fault levels, especially L-G values, with Greenfield, St. Clair and four Lambton units in service indicate that the Lambton 230 kV breakers are inadequate for interrupting the expected fault

duty that would be imposed on them. Replacing these breakers with 80 kA units is currently not considered to be economically practical.

With Greenfield, St. Clair and only Lambton G3 & G4 units in service, some fault levels are higher than the interrupting capability of the 'A' rated breakers PL4 and KL4. However, when specific fault contributions are considered, the actual fault interrupting duty imposed on these breakers does not exceed their interrupting capability.

To reduce the high fault levels at Lambton SS, while also providing some margin at Lambton SS for future developments both within Michigan and Ontario, the IESO requires that the Lambton 230 kV bus be operated 'split' (breakers P1P2 and K1K2 open), such that the north and south switchyards are not electrically tied together, whenever there are two or more Lambton units in service.

The 'split' operation of the Lambton 230 kV bus will require the St. Clair 230 kV bus-tie breaker T3T4 to be operated normally-open. If not, the Lambton north and south buses would be electrically tied together through the St. Clair facility.

Since the Lambton 230 kV bus will be required to be operated 'split' whenever there are two or more Lambton units dispatched with Greenfield and St. Clair in service, the worst case fault levels at the Lambton 230 kV bus are expected to occur when the Lambton 230 kV bus is operated closed with Greenfield, St. Clair and one Lambton TGS unit in service. Although this case was not explicitly studied by Hydro One, fault levels for this case would be approximately half of the difference between the values show in row 4 and row 5 of Table 1, resulting in the following values: symmetrical 3-phase - 60.37 kA, symmetrical L-G - 63.45 kA, asymmetrical 3-phase - 76.38 kA and asymmetrical L-G - 71.02 kA.

The specific circuit terminations required at the north and south switchyards for operating the Lambton 230 kV bus 'split' is discussed in section 7 'Assessment of Transfer Capability' of this Report.

Fault levels with the Lambton 230 kV bus 'split' and reconfigured (specific circuit terminations) are provided in section 8 'Assessment of Fault Levels with Lambton 'Split' & Reconfigured (Lambton 230 kV Bus Open)' of this Report.

Sarnia-Scott TS – 230 kV bus

Diagram 5 shows the Sarnia-Scott 230 kV switchyard.

Table 2: Fault Levels on the Sarnia-Scott 230 kV bus for a pre-fault voltage of 250 kV (Lambton 230 kV bus closed, Greenfield 230 kV bus open & St. Clair 230 kV bus closed)

| | Symmetrical Fault (kA) | | Asymmetrical Fault (kA) | | Breaker Capabilities (kA) @ 250 kV | | | |
|---|------------------------|-------|-------------------------|-------|------------------------------------|------|--------------|-------------|
| | 3-phase | L-G | 3-phase | L-G | Symmetrical | | Asymmetrical | |
| Existing with 0 Lambton units | 32.48 | 29.96 | 38.84 | 32.56 | A | 39.7 | A | 46.2 |
| Existing with 4 Lambton units | 37.19 | 33.60 | 44.75 | 36.26 | B | 63 | B | 73.9 |
| Existing with Greenfield, St. Clair & 4 Lambton units | 43.03 | 38.72 | 51.86 | 41.41 | C | 63 | C | 77.3 |
| Existing with Greenfield, St. Clair & Lambton G3 & G4 units | 41.48 | 37.77 | 49.97 | 40.41 | D | 63 | D | 77.6 |
| Existing with Greenfield, St. Clair & 0 Lambton units | 39.65 | 36.58 | 47.89 | 39.16 | A | 39.7 | A | 46.2 |
| | | | | | B | 63 | B | 73.9 |
| | | | | | C | 63 | C | 77.3 |
| | | | | | D | 63 | D | 77.6 |

Note: The 'A' rating applies to breakers AL21, AL3, HL23, L21L27, L6L23 & L7L22; the 'B' rating to breaker AL25, the 'C' rating to breakers HL22 & HL27, and the 'D' rating to breakers L3L6 & L7L25.

Table 2 indicates that the 3-phase symmetrical and asymmetrical fault levels at the Sarnia-Scott 230 kV bus exceed the interrupting capability of the 'A' rated breakers with Greenfield, St. Clair and four Lambton units in service. After allowing for the specific fault contributions that the individual breakers are not required to interrupt, Table 3 shows the worst case fault interrupting duty imposed on each of the 'A' rated breakers. The fault duty on breakers AL21, AL3, L21L27, L6L23 and L7L22 exceed their fault interrupting capabilities.

Table 3: Fault Duty on Sarnia-Scott 'A' rated 230 kV breakers with Greenfield, St. Clair & four Lambton units in service & Lambton 230 kV bus closed

| Breaker Operating Designation | Fault Duty – worst case (kA) | | Breaker Rating (kA) | |
|-------------------------------|------------------------------|--------------|---------------------|-------------|
| | 3-phase Sym | 3-phase Asym | Sym | Asym |
| AL21 | 40.84 | 49.22 | 39.7 | 46.2 |
| AL3 | 38.69 | 46.63 | | |
| HL23 | 34.47 | 41.66 | | |
| L21L27 | 40.84 | 49.22 | | |
| L6L23 | 39.82 | 47.99 | | |
| L7L22 | 40.84 | 49.22 | | |

With Greenfield, St. Clair and only Lambton G3 and G4 in service and considering the specific fault contributions each breaker is required to interrupt, the fault interrupting capability for breakers AL21, L21L27 and L7L22 is exceeded as shown in Table 4.

Table 4: Fault Duty on Sarnia-Scott ‘A’ rated 230 kV breakers with Greenfield, St. Clair & Lambton units G3 & G4 in service & Lambton 230 kV bus closed

| Breaker Operating Designation | Fault Duty – worst case (kA) | | Breaker Rating (kA) | |
|-------------------------------|------------------------------|--------------|---------------------|-------------|
| | 3-phase Sym | 3-phase Asym | Sym | Asym |
| AL21 | 39.32 | 47.35 | 39.7 | 46.2 |
| AL3 | 37.16 | 44.76 | | |
| HL23 | 33.54 | 40.39 | | |
| L21L27 | 39.32 | 47.35 | | |
| L6L23 | 38.28 | 46.10 | | |
| L7L22 | 39.32 | 47.35 | | |

With Greenfield, St. Clair and zero Lambton units in service and considering the specific 3-phase asymmetrical fault contributions each breaker is required to interrupt, the fault interrupting capability is not exceeded for any of the ‘A’ rated breakers as shown in Table 5.

Table 5: Fault Duty on Sarnia-Scott ‘A’ rated 230 kV breakers with Greenfield, St. Clair & zero Lambton units in service & Lambton 230 kV bus closed

| Breaker Operating Designation | Fault Duty – worst case (kA) | | Breaker Rating (kA) | |
|-------------------------------|--|--------------|---------------------|------|
| | 3-phase Sym | 3-phase Asym | Sym | Asym |
| AL21 | Total sym fault less than breaker rating | 45.29 | 39.7 | 46.2 |
| AL3 | | 42.69 | | |
| HL23 | | 39.02 | | |
| L21L27 | | 45.29 | | |
| L6L23 | | 44.01 | | |
| L7L22 | | 45.29 | | |

Splitting the Lambton 230 kV bus is expected to only have a small beneficial effect on the 230 kV fault levels at Sarnia-Scott TS. The specific ‘A’ rated breakers exceeding their interrupting capability with Lambton ‘split’ is discussed in the section 8 ‘Assessment of Fault Levels with Lambton Split & Reconfigured (Lambton 230 kV Bus Open)’ of this Report.

Sarnia-Scott TS – 115 kV bus

Diagram 5 shows the Sarnia-Scott 115 kV switchyard.

Table 6: Fault Levels on the Sarnia-Scott 115 kV bus for a pre-fault voltage of 127 kV (Lambton 230 kV bus closed, Greenfield 230 kV bus open & St. Clair 230 kV bus closed)

| | Symmetrical Fault (kA) | | Asymmetrical Fault (kA) | | Breaker Capabilities (kA) @ 127 kV | | | |
|---|------------------------|-------|-------------------------|-------|------------------------------------|------|--------------|------|
| | 3-phase | L-G | 3-phase | L-G | Symmetrical | | Asymmetrical | |
| Existing with 0 Lambton units | 19.54 | 23.13 | 25.75 | 26.90 | A | 38.8 | A | 45.5 |
| | | | | | B | 42 | B | 45.5 |
| | | | | | C | 52 | C | 61 |
| | | | | | D | 63 | D | 74 |
| Existing with 4 Lambton units | 20.33 | 23.99 | 26.07 | 27.46 | A | 38.8 | A | 45.5 |
| | | | | | B | 42 | B | 45.5 |
| | | | | | C | 52 | C | 61 |
| | | | | | D | 63 | D | 74 |
| Existing with Greenfield, St. Clair & 4 Lambton units | 21.14 | 24.92 | 27.31 | 28.76 | A | 38.8 | A | 45.5 |
| | | | | | B | 42 | B | 45.5 |
| | | | | | C | 52 | C | 61 |
| | | | | | D | 63 | D | 74 |
| Existing with Greenfield, St. Clair & Lambton G3 & G4 units | 20.94 | 24.73 | 26.99 | 28.77 | A | 38.8 | A | 45.5 |
| | | | | | B | 42 | B | 45.5 |
| | | | | | C | 52 | C | 61 |
| | | | | | D | 63 | D | 74 |
| Existing with Greenfield, St. Clair & 0 Lambton units | 20.70 | 24.49 | 26.96 | 28.77 | A | 38.8 | A | 45.5 |
| | | | | | B | 42 | B | 45.5 |
| | | | | | C | 52 | C | 61 |
| | | | | | D | 63 | D | 74 |

Note: The 'A' rating applies to breaker KL7, L5L7 & PL5, the 'B' rating to breaker L1L6, the 'C' rating to breaker KL2, the 'D' rating to breakers KL1, L2L4, PL4 & PL6.

Fault levels on the Sarnia-Scott 115 kV bus are below the interrupting capabilities of breakers.

Splitting the Lambton 230 kV bus is expected to have no beneficial effect on the 115 kV fault levels at Sarnia-Scott TS.

– End of Section –

7. Assessment of Transfer Capability

The effect of ‘splitting’ the 230 kV bus at Lambton (breakers P1P2 and K1K2 open) was investigated using linear load flow studies to determine a circuit arrangement for the north and south switchyards that preserved existing transfer capabilities into and out of Lambton SS.

Linear load flow studies assumed Greenfield, St. Clair and four Lambton units in service, the worst case for examining the effect on transfer capability.

Initial Requirements for Lambton 230 kV ‘Split’ Bus Arrangement

At times, the Ontario-Michigan tie-lines L4D and L51D are major contributors to the power flows at Lambton SS. For a ‘split’ operation of the Lambton 230 kV bus, one of the two interconnections terminated in the south switchyard would need to be re-terminated to the north switchyard to balance the power flows between the two switchyards.

Currently, 230 kV double circuit lines L23N/L25N and L24L/L26L are terminated in the north switchyard, while 230 kV double circuit line L28C/L29C is terminated in the south switchyard. In order to maintain balanced eastward power flows from the north and south switchyards, the three double circuit lines, L23N/L25N, L24L/L26L and L28C/L29C, would each need to have one circuit connected to the north switchyard and its companion circuit connected to the south switchyard.

With the incorporation of St. Clair on circuits L25N and L27N, these circuits must not be terminated to the same switchyard in order to maintain balanced power flows in the north and south switchyards. This specific requirement is currently met with the existing terminations of L25N and L27N at Lambton SS.

In addition, due to information received from Hydro One relating to space limitations, cost implications and ease of work at Lambton, the south switchyard is to be limited to a total of four 230 kV circuits (includes one Greenfield connection) and one Ontario-Michigan tie-line. As a result of this south switchyard limitation, the north switchyard is to have a total of five 230 kV circuits (includes the remaining Greenfield connection) and one Ontario-Michigan tie-line.

With the Greenfield 230 kV ring bus operated normally open, the Greenfield connection with steam turbine generator G4 could provide up to approximately 70% more power than the other Greenfield connection at Lambton. Furthermore, with phase angle regulators (PARs) PS4 and PS51 currently not regulating and on their neutral taps, tie-line L51D has a higher impedance than tie-line L4D. As a result, higher power flows by up to approximately 20% occur on L4D. However, it is recognized that equal flows on L4D and L51D are expected to occur when the PARs are required to regulate.

Based on the higher number of Lambton by Sarnia-Scott, Lambton by Longwood and Lambton by Chatham 230 kV circuits to be terminated in the north switchyard, the IESO requires the higher generation Greenfield connection (G1 and G4) to be terminated in the north switchyard to provide a better pre-contingency transfer capability out of Lambton. To offset the higher power flows in the

north switchyard due the Greenfield G1 and G4 connection, the IESO requires tie line L51D re-terminated to the north switchyard.

Finally, to preserve the existing Ontario-Michigan import transfer capability and the existing transfer capability into Lambton via tie-lines L4D and L51D, the Greenfield connections at Lambton SS must be arranged so as to:

- avoid the loss of an Ontario-Michigan tie-line (L4D or L51D) and Greenfield generation for a breaker-fail condition, and
- avoid the loss of Lambton generation and Greenfield generation for a P1P2 or K1K2 breaker –fail condition.

Transfer Interfaces near Lambton SS

Diagram 6 shows the ‘Lambton Input’ and ‘Sarnia Out’ transfer interfaces that were examined in the linear load flow studies. The ‘Lambton Input’ interface is defined as tie-lines L4D and L51D into Lambton. The ‘Sarnia Out’ interface is defined as 230 kV circuits L23N, L25N and L27N into Sarnia-Scott TS and 230 kV circuits L24L, L26L, L28C and L29C away from Lambton.

To preserve the existing ‘Lambton Input’ and ‘Sarnia Output’ transfer capabilities and assuming the initial requirements previously detailed for a ‘split’ operation of the Lambton 230 kV bus, the IESO examined various diameter arrangements for the 230 kV circuits and tie-lines at Lambton. As a starting point for these studies, L51D, L23N, L24L, L27N, L29C and Greenfield (G1 & G4) are assumed terminated in the north switchyard and L4D, L25N, L26L, L28C and Greenfield (G2 & G3) are assumed terminated in the south switchyard.

The studies showed that the loss of a Lambton by Longwood circuit plus a Lambton by Chatham circuit or a Lambton by Sarnia circuit due to a breaker-fail condition were limiting contingencies and reduce the ‘Sarnia Output’ transfer capability. However, the loss of Lambton by Longwood circuit with a Greenfield connection due to a breaker-fail condition did not reduce the ‘Sarnia Output’ transfer capability. Therefore, IESO requires each Greenfield connection to be connected adjacent to a Lambton by Longwood circuit.

Based on this requirement of a Greenfield and Lambton by Longwood circuit diameter arrangement for both the north and south switchyards, a new connection arrangement was derived that preserved the existing ‘Lambton Input’ and ‘Sarnia Output’ transfer capabilities with a ‘split’ operation of the Lambton 230 kV bus, and minimized the number of circuits to be re-terminated between the north and south switchyards.

The IESO requires circuits L51D, L24L, L23N, L25N, L29C and Greenfield (G1 & G4) to be terminated in the north switchyard and circuits L4D, L26L, L27N, L28C and Greenfield (G2 & G3) to be terminated in the south switchyard, according to the diameter arrangements shown in Diagram 7. (Please note that some of the breaker operating designations need to change as a result of the circuit reconfigurations.)

Table 7 summarizes the ‘Lambton Input’ and ‘Sarnia Output’ transfer capabilities for the existing Lambton configuration and the Lambton ‘split’ and reconfigured configuration without and with generation rejection (G/R), as shown in Diagram 4. These limits are the direct result of thermal limitations of certain circuits under contingency conditions.

Table 7: ‘Lambton Input’ & ‘Sarnia Output’ Transfer Capabilities

| Interfaces | Existing Lambton Configuration as shown in Diagram 3 | Lambton ‘Split’ and Reconfigured without G/R as shown in Diagram 7 | Lambton ‘Split’ and Reconfigured with G/R as shown in Diagram 7 |
|---------------|--|--|---|
| Lambton Input | 1,086 MW | 1,380 MW | 1,380 MW |
| Sarnia Output | 2,895 MW | 2,323 MW | 3,067 MW |

To achieve the existing ‘Sarnia Output’ transfer capability with Lambton ‘split’ and reconfigured, G/R at Greenfield and St. Clair is required for various Lambton by Sarnia-Scott (L23N, L25N & L27N), the Lambton by Chatham (L28C & L29C) and the Lambton by Longwood (L24L & L26L) circuit contingencies.

It should also be noted that the proposed connection arrangement meets all initial identified requirements except one. The initial requirement to connect one circuit of the L23N/L25N double circuit line to the north switchyard and other to the south switchyard is not achieved. However, it was determined that the loss of this double circuit line when connected to the north switchyard is not limiting.

To implement the connection arrangement for the incorporation of Greenfield and a ‘split’ operation of Lambton 230 kV bus, Hydro One must complete the following work at Lambton:

- connect Greenfield (G1 & G4) to the new diameter in the position by the K1 bus,
- re-terminate circuit L24L to the new diameter in the position by the P2 bus,
- re-terminate circuit L51D to the vacated L24L position,
- connect Greenfield (G2 & G3) to the vacated L51D position, and
- interchange circuits L26L and L29C positions.

Changes to the Coal Replacement Plan involving Lambton TGS

As shown in Diagram 7, the Lambton TGS units G1 and G2 are connected in the north switchyard, and units G3 and G4 are connected in the south switchyard.

Should changes be made to the Coal Replacement Plan such that the Lambton ‘scrubber’ equipped units G3 and G4 are not phased out after the in-service dates of Greenfield and St. Clair, the total generation would not be balanced on the north and south buses at Lambton SS.

Although this connection arrangement is not ideal, the specified reconfiguration of Lambton SS for a ‘split’ operation of the Lambton 230 kV bus is adequate to support the long term operation of Lambton units G3 and G4, while providing an improvement in the ‘Lambton Input’ and ‘Sarnia Output’ transfer capabilities.

– End of Section –

8. Assessment of Fault Levels with Lambton 'Split' & Reconfigured (Lambton 230 kV bus Open)

With the Lambton 230 kV bus 'split' and reconfigured according to Diagram 7, Hydro One completed additional fault level studies with two and four Lambton units in service, and Greenfield and St. Clair incorporated. The Tables below provide a summary of the faults levels at the Lambton 230 kV north and south switchyards, the Sarnia-Scott 230 kV bus and the Sarnia-Scott 115 kV bus.

Table 8: Fault Levels with Lambton 230 kV bus 'split' & reconfigured with Greenfield, St. Clair, and 4 Lambton units in service (Greenfield & St. Clair 230 kV buses open)

| | Symmetrical Fault (kA) | | Asymmetrical Fault (kA) | | Breaker Capabilities (kA) | |
|--|------------------------|-------|-------------------------|-------|---------------------------|--------------------------------|
| | 3-phase | L-G | 3-phase | L-G | Symmetrical | Asymmetrical |
| Lambton 230 kV north switchyard (pre-fault voltage 250 kV) | 46.57 | 50.41 | 58.40 | 60.03 | 70 | 92 |
| Lambton 230 kV south switchyard (pre-fault voltage 250 kV) | 43.03 | 47.32 | 54.12 | 57.75 | 65, 70 | 78, 92 |
| Sarnia-Scott 230 kV bus (pre-fault voltage 250 kV) | 42.44 | 38.37 | 51.23 | 41.04 | 39.7 , 63 | 46.2 , 73.9, 77.3, 77.6 |
| Sarnia-Scott 115 kV bus (pre-fault voltage 127 kV) | 21.07 | 24.85 | 27.43 | 28.98 | 38.8, 42, 52, 63 | 45.5, 61, 74 |

Note: See Tables in section 6 'Assessment of Fault Levels' for specific breaker ratings at Lambton SS and Sarnia-Scott TS.

Table 9: Fault Levels with Lambton 230 kV bus 'split' & reconfigured with Greenfield, St. Clair and Lambton units G3 & G4 in service (Greenfield & St. Clair 230 kV buses open)

| | Symmetrical Fault (kA) | | Asymmetrical Fault (kA) | | Breaker Capabilities (kA) | |
|--|------------------------|-------|-------------------------|-------|---------------------------|--------------------------------|
| | 3-phase | L-G | 3-phase | L-G | Symmetrical | Asymmetrical |
| Lambton 230 kV north switchyard (pre-fault voltage 250 kV) | 38.76 | 38.12 | 47.92 | 40.32 | 70 | 92 |
| Lambton 230 kV south switchyard (pre-fault voltage 250 kV) | 42.52 | 46.81 | 53.51 | 56.93 | 65, 70 | 78, 92 |
| Sarnia-Scott 230 kV bus (pre-fault voltage 250 kV) | 40.30 | 37.01 | 48.60 | 39.62 | 39.7 , 63 | 46.2 , 73.9, 77.3, 77.6 |
| Sarnia-Scott 115 kV bus (pre-fault voltage 127 kV) | 20.78 | 24.57 | 27.07 | 28.88 | 38.8, 42, 52, 63 | 45.5, 61, 74 |

Note: See Tables in section 6 'Assessment of Fault Levels' for specific breaker ratings at Lambton SS and Sarnia-Scott TS.

In comparing Tables 8 and 9 with rows 3 and 4 of Tables 1, 2 and 6, respectively, splitting the Lambton 230 kV bus results in a significant reduction of faults levels at the Lambton 230 kV north and south switchyards, a small reduction at the Sarnia-Scott 230 kV bus, and virtually no change at the Sarnia-Scott 115 kV bus.

Fault levels at the Lambton 230 kV north and south switchyards and the Sarnia-Scott 115 kV bus do not exceed the interrupting capabilities of the breakers.

With four Lambton units, Greenfield and St. Clair in service, the 3-phase symmetrical and asymmetrical fault levels at the Sarnia-Scott 230 kV bus remain high relative to the lower ‘A’ rated breakers AL21, AL3, HL23, L21L27, L6L23 and L7L22. As shown in Table 10, the interrupting capabilities for breakers AL21, L21L27, L6L23 and L7L22 are exceeded after determining the actual fault duty imposed on these breakers for different fault locations at the bus.

Table 10: Fault Duty on Sarnia-Scott ‘A’ rated 230 kV breakers with Greenfield, St. Clair & four Lambton units in service & Lambton 230 kV bus ‘split’

| Breaker Operating Designation | Fault Duty – worst case (kA) | | Breaker Rating (kA) | |
|-------------------------------|------------------------------|--------------|---------------------|-------------|
| | 3-phase Sym | 3-phase Asym | Sym | Asym |
| AL21 | 40.24 | 48.57 | 39.7 | 46.2 |
| AL3 | 38.09 | 45.97 | | |
| HL23 | 34.85 | 42.06 | | |
| L21L27 | 40.24 | 48.57 | | |
| L6L23 | 39.23 | 47.35 | | |
| L7L22 | 40.24 | 48.57 | | |

With only the Lambton G3 and G4 units, Greenfield and St. Clair in service, the fault levels are also higher than the lower ‘A’ rated 230 kV Sarnia-Scott breakers. However, the actual fault duty imposed on breakers AL21, L21L27, L6L23 and L7L22 does not exceed the interrupting capabilities of these breakers as shown in Table 11.

Table 11: Fault Duty on Sarnia-Scott ‘A’ rated 230 kV breakers with Greenfield, St. Clair & Lambton units G3 & G4 in service & Lambton 230 kV bus ‘split’

| Breaker Operating Designation | Fault Duty – worst case (kA) | | Breaker Rating (kA) | |
|-------------------------------|------------------------------|--------------|---------------------|------|
| | 3-phase Sym | 3-phase Asym | Sym | Asym |
| AL21 | 39.31 | 45.97 | 39.7 | 46.2 |
| AL3 | 35.97 | 43.37 | | |
| HL23 | 33.72 | 40.67 | | |
| L21L27 | 39.31 | 45.97 | | |
| L6L23 | 37.09 | 44.73 | | |
| L7L22 | 39.31 | 45.97 | | |

Therefore, to allow for the possible dispatch of more than two Lambton units with Greenfield and St. Clair in service, Hydro One must replace Sarnia-Scott 230 kV breakers AL21, L21L27, L6L23 and L7L22 with higher rated units as a requirement for incorporating Greenfield and St. Clair.

Comparison of Fault Levels – Existing Lambton 230 kV Bus Closed vs. Lambton 230 kV Bus 'Split' & Reconfigured

Table 12 shows the change in bus fault levels at the Lambton 230 kV, Sarnia-Scott 230 kV and Sarnia-Scott 115 kV buses when the Lambton 230 kV bus is operated 'split' with Greenfield, St. Clair and four Lambton TGS units in service versus the existing closed operation of the Lambton 230 kV bus with four Lambton TGS units in service.

Table 12: Change in Fault Levels – Existing Lambton 230 kV Bus Closed to Lambton 230 kV Bus 'Split' & Reconfigured

| | Δ Symmetrical Fault (kA) | | Δ Asymmetrical Fault (kA) | |
|---------------------------------|--------------------------|--------|---------------------------|--------|
| | 3-phase | L-G | 3-phase | L-G |
| Lambton 230 kV north switchyard | -10.20 | -12.21 | -13.16 | -19.60 |
| Lambton 230 kV south switchyard | -13.74 | -15.30 | -17.44 | -21.88 |
| Sarnia-Scott 230 kV bus | +5.25 | +4.77 | +6.48 | +4.78 |
| Sarnia-Scott 115 kV bus | +0.74 | +0.86 | +1.36 | +1.52 |

Worst Case Fault Levels

As already stated in section 6 'Assessment of Fault Levels, Lambton SS – 230 kV bus closed', the fault level results for a 'split' operation of the Lambton 230 kV bus confirm that the worst case Lambton 230 kV bus fault levels will occur when the Lambton 230 kV bus is operated closed with Greenfield, St. Clair and one Lambton TGS unit in service. For these operating conditions, the following fault levels are possible: symmetrical 3-phase - 60.37 kA, symmetrical L-G - 63.45 kA, asymmetrical 3-phase - 76.38 kA and asymmetrical L-G - 71.02 kA.

At Sarnia-Scott TS, the worst case 230 kV and 115 kV bus fault levels are expected to occur when the Lambton 230 kV bus is operated 'split' with Greenfield, St. Clair and four Lambton TGS units in service as shown in Table 8, rows 3 and 4, respectively.

Fault Level Restrictions on Other Station Equipment

The previous fault level assessments in this Report were based only on breaker short capabilities at Lambton SS and Sarnia-Scott TS.

Hydro One is expected to examine the effect that the increased fault levels may have on the remaining station equipment (buswork, disconnect switches, etc.) at Lambton SS and Sarnia-Scott TS, and make any required enhancements to the equipment. This examination should be based on the expected worst cases for fault levels.

– End of Section –

9. Assessment of a Greenfield x Lambton 230 kV Transmission Circuit Outage

The new Greenfield 230 kV transmission circuits connecting to Lambton will be adequately sized to allow the full plant output to flow on one circuit should the companion circuit be unavailable.

Breaker Thermal Assessment at Lambton SS

With one Greenfield by Lambton circuit out of service, up to approximately 3,000 A could flow on the remaining Greenfield circuit and into the diameter position at Lambton SS. Under certain breaker maintenance outages and operating conditions, 3,000 A or more could also flow through the breakers associated with each diameter that has a Greenfield connection.

As shown in Diagram 7, the Greenfield connection in the Lambton north switchyard will be connected to a line position in the new diameter.

Hydro One must ensure that the new 230 kV breakers P1, K1P1 and K1 are rated at least 3,000 A.

As also shown in Diagram 7, the Greenfield connection in the Lambton south switchyard will be connected to the vacated L51D position. The diameter associated this line position has breakers KL29, L51L29 and PL51. These breakers are currently rated for 2,000 A.

Hydro One must replace Lambton 230 kV breakers KL29, L51L29 and PL51 with higher rated units of least 3,000 A.

Fault Levels at Lambton SS

With all Greenfield generators dispatched on a single Greenfield by Lambton circuit and the Lambton 230 kV bus operated 'split', fault levels for a 3-phase or L-G fault would increase in the Lambton switchyard associated with the single circuit connection when compared to fault levels for the normal, two circuit operation of Greenfield into Lambton SS.

With all of Greenfield connected to the south switchyard, the additional generation (worst case - approximately 727 MW) would cause the fault levels to increase by approximately 10 kA for a 3-phase fault. The increase in generation would also cause fault levels to increase by at least 10 kA for a L-G fault.

Table 8, row 2 shows the Lambton south switchyard fault levels for operation of the Lambton 230 kV bus open with Greenfield, St. Clair and four Lambton TGS units in service, and the interrupting capabilities of south switchyard breakers. By comparing the fault levels to the breaker interrupting

capabilities, the resulting margins are expected to be sufficient for any increase in fault levels should all of Greenfield be connected to the south switchyard.

With all of Greenfield connected to the north switchyard, the increased generation (worst case - approximately 420 MW) would cause the fault levels to increase by approximately 5 kA for a 3-phase fault and at least 5 kA for a L-G fault.

Table 8, row 1 shows the Lambton north switchyard fault levels for operation of the Lambton 230 kV bus open with Greenfield, St. Clair and four Lambton TGS units in service, and the interrupting capabilities of north switchyard breakers. By comparing the fault levels to the breaker interrupting capabilities, the resulting margins are expected to be sufficient for any increase in fault levels should all of Greenfield be connected to the north switchyard.

With all Greenfield generators dispatched on a single Greenfield by Lambton circuit and the Lambton 230 kV operated closed, fault levels for a 3-phase or L-G fault in the Lambton switchyard would be similar to those levels already provided in this Report for the normal, two circuit operation of Greenfield with the Lambton 230 kV bus operated closed.

'Sarnia Output' Transfer Capability

The 'Sarnia Output' interface is defined as 230 kV circuits L23N, L25N and L27N into Sarnia-Scott TS and 230 kV circuits L24L, L26L, L28C and L29C away from Lambton as shown in Diagram 6. For a 'split' operation of the Lambton 230 kV bus, this interface transfer limit will be 3,067 MW with G/R as shown in Table 7.

If one of the 230 kV circuits from Greenfield to Lambton is out of service and Lambton SS is required to be operated 'split' because more than one Lambton units is dispatched, then the entire Greenfield output could be injected either into the north or the south switchyard. Under these conditions, the 'Sarnia Output' transfer capability will be lower. This transfer capability will depend on the imbalance between the power injected into the Lambton north switchyard and Lambton south switchyard.

Additional linear flow studies were completed to determine the effect of the Greenfield circuit outage on the transfer capability of the 'Sarnia Output' transmission interface for the worst scenario.

With four Lambton units dispatched, the transfer capability of the 'Sarnia Output' interface is limited to approximately 1,600 MW with G/R when all of Greenfield is connected to the Lambton north switchyard, and to approximately 1,555 MW with G/R when all of Greenfield is connected to the Lambton south switchyard. These values would represent the worst case transfer capabilities.

The IESO recognizes that under Greenfield line outage conditions, and with all Lambton and Greenfield generation in service the 'Sarnia Output' interface transfer capability will be lower. The IESO considers that the conditions that would result in a lower transfer capability will occur rarely and only during the period when Greenfield, St. Clair and Lambton TGS are in service such that the 'split' operation of the Lambton 230 kV bus is required. Therefore, the IESO does not require any network enhancements to improve the 'Sarnia Output' transfer capability.

– End of Section –

10. Special Protection Systems

Existing Lambton Generation Rejection (G/R) Scheme

The existing Lambton G/R Scheme is employed as a means of increasing the power transfer capability of the Ontario-Michigan interconnection under export conditions. The Scheme is capable of rejecting one unit at Lambton TGS to prevent the post-contingency thermal overloading of the Ontario to Michigan interconnection circuits for contingencies involving tie-line L4D or L51D, as well as breaker-fail contingencies at Lambton SS.

The Scheme is event-based. A contingency is recognized by monitoring various protections which operate and trip system elements when an event occurs. On detection of a protection operation, the Lambton G/R Scheme initiates G/R of a Lambton TGS unit if pre-armed.

Existing Sarnia-Scott G/R Scheme

The existing Sarnia-Scott G/R is employed as a means of preventing the post-contingency thermal overloading of circuits emanating from Sarnia-Scott TS. The Scheme is capable of rejecting generating units at Imperial Oil and TransAlta Sarnia. The Scheme also provides for the run-back of generating unit at TransAlta Sarnia.

The Scheme is connectivity-based. An event on the IESO-controlled grid is detected by monitoring the status of breaker positions. A circuit contingency is considered to have taken place if both of its terminal breakers are detected open. Consequently, rejection or run-back is initiated if pre-armed.

G/R of Greenfield

Greenfield is required to participate in a G/R Scheme that would allow the current Ontario-Michigan power transfer capability to be maintained under export conditions for contingencies involving L4D or L51D. Since the existing Lambton G/R Scheme is located at Lambton TGS, the modification of this Scheme for Greenfield is not considered feasible due to the planned shutdown of Lambton TGS. Therefore, a new G/R Scheme that is connectivity-based must be installed at Lambton SS.

As previously described in section 7 'Assessment of Transfer Capability' of this Report, to maintain the existing 'Sarnia Output' transfer capability when the Lambton 230 kV bus is operated 'split', the new Scheme must be capable of rejecting Greenfield generation for the following additional contingency conditions:

- 230 kV circuits L24L and/or L26L
- 230 kV circuits L28C and/or L29C
- 230 kV circuits L23N and/or L25N and/or L27N

Since contingencies involving 230 kV circuits L23N, L25N and L27N are also addressed by the existing Sarnia-Scott G/R Scheme, this would then allow possible LEO (line-end-open) conditions involving these circuits to be addressed by either Scheme.

Depending on the generation dispatch in the Windsor/Lambton areas and Michigan imports, the loss of 230 kV circuits N22W and W44LC for a Buchanan L22L44 breaker-fail condition is a concern that may result in possible thermal overloads on the remaining 230 kV circuits N21W and W45LC. This contingency is, therefore, required to be monitored by the new Lambton G/R Scheme.

Due to its close proximity to Sarnia-Scott TS there may also be a requirement to select generating units at Greenfield for contingencies involving 230 kV circuits N21W and/or N22W.

The new Lambton G/R Scheme with the existing Sarnia-Scott G/R Scheme would collectively monitor these contingencies. This suggests that the two G/R Schemes should be integrated to both allow G/R tripping of Greenfield from both Schemes.

Greenfield is designed as a three gas turbine to one steam turbine combined cycle generating facility. Since Greenfield is not designed to operate on a continuous basis without steam turbine generator G4 in service, gas-fired generators G1, G2 and G3 must be made available for G/R. For each gas-fired unit rejected there will be a corresponding drop in the G4 output. Rejection of the three gas units would result in the complete loss of G4.

The IESO requires Hydro One to install a new connectivity-based G/R Scheme at Lambton SS and modify the existing Sarnia-Scott G/R Scheme to allow the tripping of Greenfield.

The IESO requires Greenfield to install facilities to accept G/R signals from both Schemes and trip gas-fired generators G1, G2, and G3 individually, any pair or all three when pre-armed.

G/R of St. Clair

Since St. Clair will have a direct effect on the power flows of 230 kV circuits L23N, L25N and L27N, it will be required to participate in a G/R Scheme to allow the rejection of generating units for contingencies involving these circuits.

In addition, since St. Clair will also affect flows on 230 kV circuits N21W and N22W between Sarnia-Scott TS and Buchanan TS, it may also be necessary to provide the capability to reject generating units at St. Clair to address possible thermal overloads resulting from contingencies involving these circuits.

Furthermore, due to its close proximity to Lambton SS there may also be a requirement to select generating units at St. Clair for contingencies involving tie-line L4D or L51D.

As previously described in section 7 'Assessment on Transfer Capability' of this Report, to maintain the existing 'Sarnia Output' transfer capability when the Lambton 230 kV bus is operated 'split', G/R of St. Clair is required for various Lambton by Chatham (L28C & L29C) and the Lambton by Longwood (L24L & L26L) circuit contingencies.

The existing Sarnia-Scott G/R Scheme with the new Lambton G/R Scheme would collectively monitor these contingencies. The L23N, L25N and L27N circuit contingencies would be monitored

by both Schemes. As mentioned before in regards to Greenfield, this suggests that the two G/R Schemes should be integrated to both allow G/R tripping of St. Clair from both Schemes.

St. Clair is designed as a combined cycle generating facility with two, one gas turbine to one steam turbine combinations. Each coupled pair of generating units (GTG3 & STG3, GTG4 & STG4) must be made to be available for G/R.

The IESO requires Hydro One to modify the existing Sarnia-Scott G/R Scheme and build the new G/R Scheme at Lambton SS to allow the tripping of St. Clair.

The IESO requires St. Clair to install facilities to accept G/R signals from both Schemes and trip coupled generators GTG3 & STG3, GTG4 & STG4 or both when pre-armed.

Additional Requirements for Existing Sarnia-Scott G/R Scheme

The loss of 230 kV circuits N21W and L27N for a Sarnia-Scott 230 kV L21L27 breaker-fail condition may result in possible thermal overloads on the remaining circuits emanating out of Sarnia-Scott TS.

As mentioned for the new Lambton G/R Scheme, the loss of 230 kV circuits N22W and W44LC for a Buchanan L22L44 breaker-fail condition is a concern that may result in possible thermal overloads on the remaining 230 kV circuits N21W and W45LC requiring the G/R tripping of TransAlta Sarnia and Imperial Oil.

Therefore, Hydro One must modify the existing Sarnia-Scott G/R Scheme to monitor a Sarnia-Scott L21L27 breaker-fail contingency and a Buchanan L22L44 breaker-fail contingency.

Integration of the new Lambton G/R Scheme and the existing Sarnia-Scott G/R Scheme

Diagram 8 provides the functional specification on integrating the new Lambton G/R Scheme and the existing Sarnia-Scott G/R Scheme for G/R tripping of Greenfield and St. Clair.

The new Lambton G/R Scheme should use a matrix arrangement of software latching relays to enable Greenfield and St. Clair to be pre-armed with the appropriate SCADA selection for specific contingency conditions. Both the contingency detection logic and selection matrix should be implemented in software.

Similarly, the existing Sarnia-Scott G/R Scheme must be modified to include software latching relays for Greenfield and St. Clair. The contingency detection logic and selection matrix must also be modified to include the loss of 230 kV circuits N21W and L27N for a Sarnia-Scott L21L27 breaker-fail condition, and the loss of 230 kV circuits N22W and W44LC for a Buchanan L22L44 breaker-fail condition.

– End of Section –

11. Assessment of Voltage Performance

Detailed load flow studies were performed to assess the effect of Greenfield and St. Clair on operating voltages in the Lambton area. In particular, post-contingency voltage declines were examined to see if they remain within criteria.

Assumptions

Two specific system conditions expected to give worst voltage performance were assumed for the studies as follows:

- a. High westward flow on BLIP (Buchanan Longwood Input) transmission interface, some Michigan import, off-peak load conditions west of Buchanan TS, and all existing generation in the Windsor/Sarnia area out of service except for approximately 200 MW in the Windsor area.
- b. Westward or eastward flow on BLIP interface, some Michigan import, on-peak load conditions west of Buchanan TS, and all existing generation in the Windsor/Sarnia area dispatched except for Lambton TGS as described below.

The BLIP transmission interface is shown in Diagram 6.

For each system scenario described above, various assumptions were also made on the number of Lambton, Greenfield and St. Clair units in service and the associated closed or ‘split’ operation of the Lambton and St. Clair 230 kV buses.

Furthermore, system voltage declines are expected to be worst when Greenfield and St. Clair are not in service at the same time. As a result, the voltage performance studies for the two facilities were completed independent of each other.

Table 13 summarizes the case studies used for Greenfield, while Table 14 summarizes the case studies used for St. Clair.

Table 13: Voltage Performance – Greenfield Case Studies

| | Case 1 | Case 1A | Case 3 | Case 3A | Case 5 | Case 5A |
|--------------------------------|-------------|---------|-------------|---------|-------------|-------------|
| System condition | A | a | b | b | b | B |
| BLIP flow (MW) | 1,110 | 1,110 | 140 | 140 | -65 | -170 |
| Lambton units in service (i/s) | 0 | 0 | 0 | 0 | 2 (G3 & G4) | 2 (G3 & G4) |
| Greenfield units i/s | 2 (G1 & G4) | 4 | 2 (G1 & G4) | 4 | 2 (G1 & G4) | 4 |
| St. Clair units i/s | 0 | 0 | 0 | 0 | 0 | 0 |
| Lambton 230 kV bus | Closed | Closed | Closed | Closed | Open | Open |
| Greenfield 230 kV bus | Open | Open | Open | Open | Open | Open |
| St. Clair 230 kV bus | Closed | Closed | Closed | Closed | Open | Open |

Table 14: Voltage Performance – St. Clair Case Studies

| | Case 2 | Case 2A | Case 4 | Case 4A | Case 6 | Case 6A |
|-----------------------|-----------------|---------|-----------------|---------|-----------------|-------------|
| System condition | A | a | B | b | b | B |
| BLIP flow (MW) | 1,670 | 1,670 | 660 | 660 | 25 | -260 |
| Lambton units i/s | 0 | 0 | 0 | 0 | 2 (G3 & G4) | 2 (G3 & G4) |
| Greenfield units i/s | 0 | 0 | 0 | 0 | 0 | 0 |
| St. Clair units i/s | 2 (GTG3 & STG3) | 4 | 2 (GTG3 & STG3) | 4 | 2 (GTG3 & STG3) | 4 |
| Lambton 230 kV bus | Closed | Closed | Closed | Closed | Open | Open |
| Greenfield 230 kV bus | Open | Open | Open | Open | Open | Open |
| St. Clair 230 kV bus | Closed | Closed | Closed | Closed | Open | Open |

Contingencies

Table 15 details the contingencies applied and associated voltage decline criterion.

Table 15: Voltage Performance – Contingency Condition and associated Voltage Decline Criterion

| Number | Contingency Condition | Voltage Decline Limit Criterion |
|--------|---|---------------------------------|
| 1 | Loss of Greenfield generators G1 & G4 | 5% (Generation contingency) |
| 2 | Loss of new 230 kV double circuit line between Greenfield and Lambton | 10% (Transmission contingency) |
| 3 | Loss of St. Clair generators GTG3 & STG3 | 5% (Generation contingency) |
| 4 | Loss of 230 kV circuits L25N and L27N | 10% (Transmission contingency) |

- Contingency number 1 was used for Greenfield cases 1, 3 and 5.
- Contingency number 2 was used for Greenfield cases 1A, 3A and 5A.
- Contingency number 3 was used for St. Clair cases 2, 4 and 6.
- Contingency number 4 was used for St. Clair cases 2A, 4A and 6A.

Results of Voltage Performance Studies

The details of the voltage performance studies (pre- and post-ULTC) for the various case studies under the specified contingency conditions are given in the Tables found in Appendix A. The following items summarize the voltage performance study results:

- In Cases 1, 3 and 5, the voltage declines associated with the loss of Greenfield G1 & G4 are within the maximum 5% criterion.
- In cases 2, 4 and 6, the voltage declines associated with the loss of St. Clair GTG3 & STG3 are within the maximum 5% criterion.

- In Cases 1A, 3A and 5A, the voltage declines associated with loss of the new 230 kV double circuit line between Greenfield and Lambton with Greenfield G1, G2, G3 and G4 in service are within the maximum 10% criterion. The largest voltage declines are observed when Lambton is operated 'split' (Case 5A).
- In Cases 2A, 4A and 6A, the voltage variations associated with loss of the 230 kV double circuit line L25N and L27N with St. Clair GTG3, STG3, GTG4 and STG4 in service are within the maximum 10% criterion. The largest voltage declines are observed when Lambton is operated 'split' (Case 6A).

The voltage performance of the power system in the Lambton area with Greenfield and St. Clair is acceptable in both the pre-contingency and post-contingency states.

– End of Section –

12. Assessment of Transient Stability

12.1 Excitation System Performance

Each synchronous generating unit that is rated at 10 MVA or larger shall be equipped with an excitation system that meets the requirements outlined in Reference 12 of Appendix 4.2 of the Market Rules. Specifically, the each excitation system must have:

- A voltage response time not longer than 50 ms for a voltage reference step change not to exceed 5%,
- A positive ceiling voltage of at least 200% of the rated field voltage, and
- A negative ceiling voltage of at least 140% of the rated field voltage.

Open-circuit response and response ratio tests were conducted for each of the exciters proposed for Greenfield and St. Clair to determine whether they would be able to comply with these requirements.

12.1.1 Greenfield

Generators

Gas-fired turbine generators G1, G2 and G3 and steam turbine generator G4 are represented by the generator parameters provided by Greenfield and shown in Table 16.

Table 16: Greenfield – Generator Parameters

| Description | Values | |
|---------------------|------------------|-------------|
| | GTGs G1, G2 & G3 | STG G4 |
| T'do (>0) (sec) | 9.03 | 6.9 |
| T''do (>0) (sec) | 0.048 | 0.031 |
| T'qo (>0) (sec) | 1 | 1.4 |
| T''qo (>0) (sec) | 0.089 | 0.05 |
| Inertia constant, H | 4.95 | 2.8* |
| Speed damping, D | 0 | 0 |
| Xd | 2.4648 | 2.06 |
| Xq | 2.3845 | 2.03 |
| X'd | 0.2421 | 0.329 |
| X'q | 0.447 | 0.538 |
| X''d = X''q | 0.1819 | 0.269 |
| Xl | 0.1526 | 0.235 |
| S(1.0) | 0.095 | 0.12 |
| S(1.2) | 0.28 | 0.42 |

* Subsequent to the completion of the SIA studies for this Report, Greenfield reported to the IESO that the inertia constant H for G4 will be 3.42.

Exciters

Generators G1, G2, G3 and G4 will be equipped with exciters represented by the IEEE Type ST1A model. Table 17 shows the data provided.

Table 17: Greenfield – ESST1A Data for Gas-fired Turbine Generators and Steam Turbine Generator

| Description | Value | |
|--------------|------------------|--------|
| | GTGs G1, G2 & G3 | STG G4 |
| TR (sec) | 0.012 | 0.02 |
| VIMAX | 10 | 0.3 |
| VIMIN | -10 | -0.3 |
| TC (sec) | 0.376 | 0.7 |
| TB (sec) | 1.25 | 2.25 |
| TC1 (sec) | 0 | 0 |
| TB1 (sec) | 0 | 0 |
| KA | 400 | 400 |
| TA (sec) | 0.02 | 0.01 |
| VAMAX | 6.76 | 7.18 |
| VAMIN | -5.41 | -4.6 |
| VRMAX | 6.76 | 7.18 |
| VRMIN | -5.41 | -4.6 |
| KC | 0.05 | 0.22 |
| KF | 0 | 0 |
| TF > 0 (sec) | 0.05 | 1 |
| KLR | 0 | 0 |
| ILR | 0 | 0 |

For these generating units, the rated field voltage at rated output would be 3.28 pu for generators G1, G2 and G3 and 2.98 pu for generator G4. Figures 1 and 2 show the results obtained from the open-circuit response test for an increase of 5% in the generator terminal voltage. The exciters are able to achieve a field voltage of the twice the rated value within the 50 ms interval, and therefore, meet the Market Rules requirements.

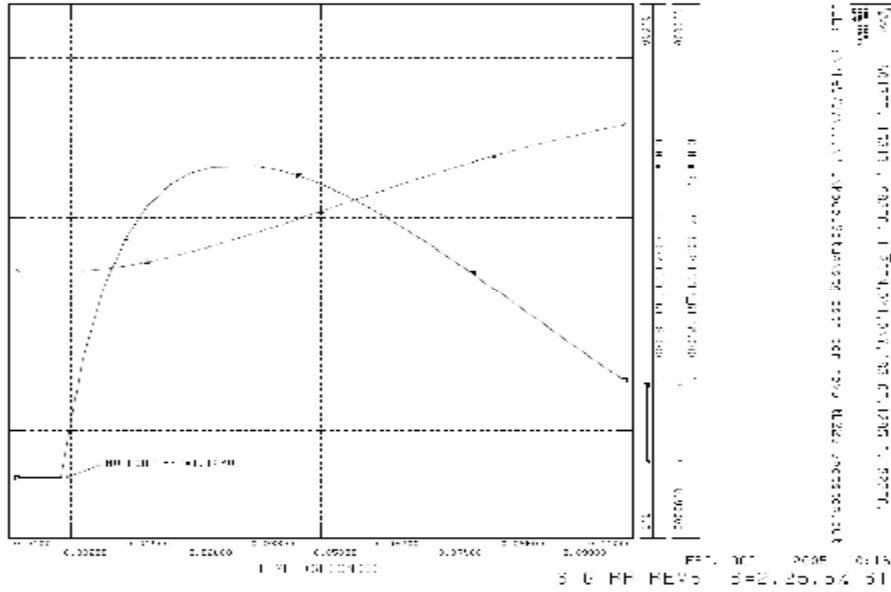

Figure 2: Greenfield – Gas-Fired Turbine Generator Open-Circuit Response

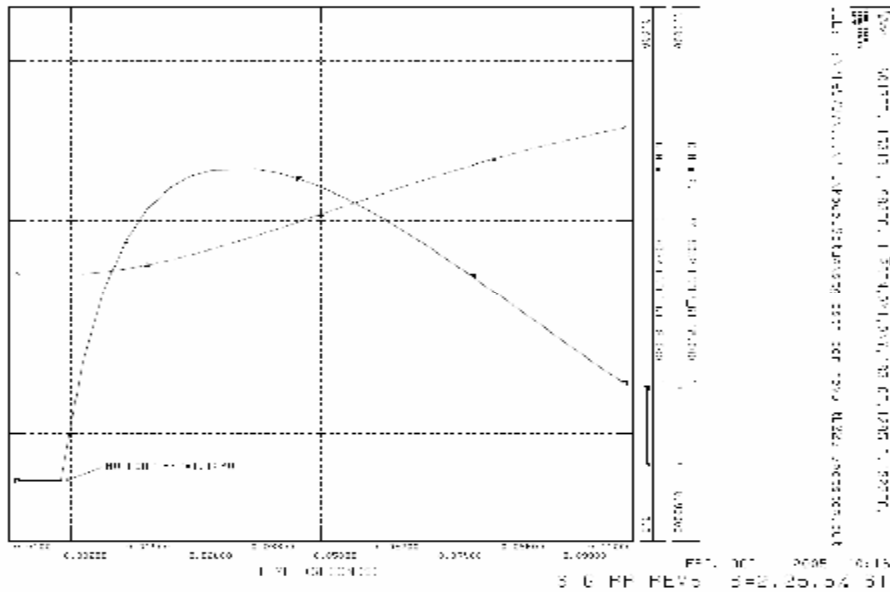

Figure 3: Greenfield – Steam Turbine Generator Open-Circuit Response

Power System Stabilizers

Table 18 shows the data that was provided for IEEE PSS2A model and IEEE PSS1A model to represent the power system stabilizers to be installed on the gas-fired turbine generators and the steam turbine generator, respectively.

Table 18: Greenfield – PSS2A Data for Gas-Fired Turbine Generators/PSS1A Data for Steam Turbine Generator

| Description | Value | |
|-------------|------------------|-----------------------------------|
| | GTGs G1, G2 & G3 | STG G4** (PSS1A variable name) |
| IC1 | 1 | 5 |
| REMBUS1 | 0 | 0 |
| IC2 | 3 | 1 |
| REMBUS2 | 0 | 0 |
| M | 5 | 0 |
| N | 1 | 0 |
| Tw1 (>0) | 10 | 2 (T5) |
| Tw2 | 10 | 0 |
| T6 | 0 | 0.03 |
| Tw3 (>0) | 10 | 1 (T6) |
| Tw4 | 0 | 0 |
| T7 | 10 | 0 |
| KS2 | 1.01 | 0 |
| KS3 | 1 | 0 |
| T8 | 0.5 | 0 |
| T9 (>0) | 0.1 | 1 |
| KS1 | 7 | 0.8 (KS) |
| T1 | 0.12 | 0.15 (T1) |
| T2 | 0.03 | 0.25 (T2) |
| T3 | 0.12 | 1 (T3) |
| T4 | 0.03 | 1 (T4) |
| VSTMAX | 0.1 | 0.1 (VSTMAX) |
| VSTMIN | -0.1 | -0.1 (VSTMIN) |

** PSS2A model used to represent PSS1A type stabilizer.

Governors

Data for a WESGOV model was provided for the governor to be installed on the gas-fired turbine generators, as shown in Table 19.

Table 19: Greenfield – WESGOV Data for Gas-Fired Turbine Generators G1, G2, & G3

| Description | Value |
|-------------|-------|
| DTC | 0.1 |
| DTP | 1 |
| DROOP | 0.04 |
| KP | 0.3 |
| TI | 6 |
| T1 | 0.5 |
| T2 | 0.59 |
| ALIM | 0.1 |
| TPE | 0.25 |

Table 20 shows the data provided for the IEESGO model for the governor to be installed on the steam turbine generator.

Table 20: Greenfield – IEESGO Data for Steam Turbine Generator G4

| Description | Value |
|---|-------|
| T1, controller lag (sec) | 0 |
| T2, controller lead compensation(sec) | 0 |
| T3, governor lag (>0) (sec) | 0.2 |
| T4, delay due to steam inlet volumes associated with steam chest and inlet piping (sec) | 0.751 |
| T5, reheater delay including hot and cold leads (sec) | 10 |
| T6, delay due to IP-LP turbine, crossover pipes, and LP end hoods (sec) | 0.85 |
| K1, 1/per unit regulation | 20 |
| K2, fraction | 0.7 |
| K3, fraction | 0.57 |
| PMAX, upper power limit | 1.1 |
| PMIN, lower power limit | 0.05 |

12.1.2 St. Clair

Generators

Gas-fired turbine generators GTG3 and GTG4 and steam turbine generator STG3 and STG4 are represented by the provided generator parameters shown in Table 21.

Table 21: St. Clair – Generator Parameters

| Description | Values | |
|---------------------|------------------|------------------|
| | GTGs GTG3 & GTG4 | STGs STG3 & STG4 |
| T'do (>0) (sec) | 5.70 | 5.10 |
| T''do (>0) (sec) | 0.034 | 0.034 |
| T'qo (>0) (sec) | 0.59 | 0.54 |
| T''qo (>0) (sec) | 0.069 | 0.073 |
| Inertia constant, H | 4.76 | 5.127 |
| Speed damping, D | 0.0 | 0.0 |
| Xd | 2.12 | 1.74 |
| Xq | 2.02 | 1.67 |
| X'd | 0.260 | 0.205 |
| X'q | 0.465 | 0.400 |
| X''d = X''q | 0.195 | 0.160 |
| Xl | 0.15 | 0.12 |
| S(1.0) | 0.0575 | 0.039 |
| S(1.2) | 0.4412 | 0.346 |

Exciters

Generators GTG3 and GTG4 will be equipped with a GE EX2000, IEEE Type ST4B static exciter. Table 22 shows the data provided.

Table 22: St. Clair – ESST4B Data for Gas-fired Turbine Generators GTG3 & GTG4

| Description | Variable Name | Value |
|------------------------------|---------------|-------|
| Voltage Transducer T.C. | TR (sec) | 0 |
| AVR Proportional Gain | KPR | 12 |
| AVR Integral Gain | KIR | 2.4 |
| AVR Positive Limit | VRMAX | 1 |
| AVR Negative Limit | VRMIN | -0.87 |
| AVR Time constant | TA (sec) | 0.01 |
| FVR Proportional Gain | KPM | 1 |
| FVR Integral Gain | KIM | 0 |
| FVR Positive Limit | VMMAX | 1 |
| FVR Negative Limit | VMMIN | -0.87 |
| FVR Feedback Gain | KG | 0 |
| Potential Forcing Term | KP | 6.7 |
| Current Forcing Term | KI | 0 |
| Limit on Forcing (XFMR sat.) | VBMAX | 8.38 |
| Commutation Loss Term | KC | 0.08 |
| p-bar Leakage reactance | XL | 0 |
| Forcing Term Angle – degrees | THETAP | 0 |

Generators STG3 and STG4 will be equipped with one of two options – A or B. Option A is an IEEE Type AC2A brushless exciter. Option B is an IEEE Type ST4B static exciter, same as the type to be installed on the gas-fired turbine generators. Tables 23 and 24 show the data provided for these options.

Table 23: St. Clair – ESAC2A Data for Steam Turbine Generators STG3 & STG4 – Option A

| Description | Variable Name | Value |
|---|---------------|-------|
| Terminal voltage transducer T.C. | Tr | 0.01 |
| AVR lag time constant | Tb | 1 |
| AVR lead time constant | Tc | 1 |
| AVR gain | Ka | 1000 |
| AVR time constant | Ta | 0.01 |
| AVR maximum limit | Vamax | 11.8 |
| AVR minimum limit | Vamin | -11.3 |
| Inner loop gain | Kb | 1 |
| Positive exciter output limit (ceiling) | Vrmax | 11.8 |
| Negative exciter output limit (ceiling) | Vrmin | -11.3 |
| Main Exciter time constant | Te | 0.78 |
| Exciter current limit | Vfemax | 6.34 |
| Inner loop feedback | Kh | 0 |
| Exciter feedback gain | Kf | 0.025 |
| Exciter feedback time constant | Tf | 1 |
| Rectifier regulation | Kc | 0.1 |
| Demagnetizing constant | Kd | 0.981 |
| Main Exciter | Ke | 1 |
| Saturation coefficient | E1 | 2.79 |
| Saturation coefficient | S(E1) | 0.009 |
| Saturation coefficient | E2 | 3.72 |
| Saturation coefficient | S(E2) | 0.015 |

Table 24: St. Clair – ESST4B Data for Steam Turbine Generators STG3 & STG4 – Option B

| Description | Variable Name | Value |
|------------------------------|---------------|-------|
| Voltage Transducer T.C. | TR (sec) | 0 |
| AVR Proportional Gain | KPR | 12 |
| AVR Integral Gain | KIR | 2.4 |
| AVR Positive Limit | VRMAX | 1 |
| AVR Negative Limit | VRMIN | -0.87 |
| AVR Time constant | TA (sec) | 0.01 |
| FVR Proportional Gain | KPM | 1 |
| FVR Integral Gain | KIM | 0 |
| FVR Positive Limit | VMMAX | 1 |
| FVR Negative Limit | VMMIN | -0.87 |
| FVR Feedback Gain | KG | 0 |
| Potential Forcing Term | KP | 5.41 |
| Current Forcing Term | KI | 0 |
| Limit on Forcing (XFMR sat.) | VBMAX | 6.49 |
| Commutation Loss Term | KC | 0.08 |
| p-bar Leakage reactance | XL | 0 |
| Forcing Term Angle – degrees | THETAP | 0 |

For these generating units, the rated field voltage at rated output would be as follows:

- 2.9 pu for the gas-fired turbine generators,
- 2.47 pu for the steam turbine generators with exciter option A, and
- 2.47 pu for the steam turbine generators with exciter option B.

Figures 3, 4 and 5 show the results obtained from the open-circuit response test for an increase of 5% in the generator terminal voltage. The steam turbine generator with exciter option A is unable to achieve a field voltage of 95% of the difference between ceiling voltage and rated field voltage within the 50 ms interval as specified in the Market Rules, and is therefore not acceptable. The gas-fired turbine generator and the steam turbine generator with exciter option B are able to achieve the specified Market Rules requirement.

St. Clair must install the static exciter type option for steam turbine generators STG3 and STG4.

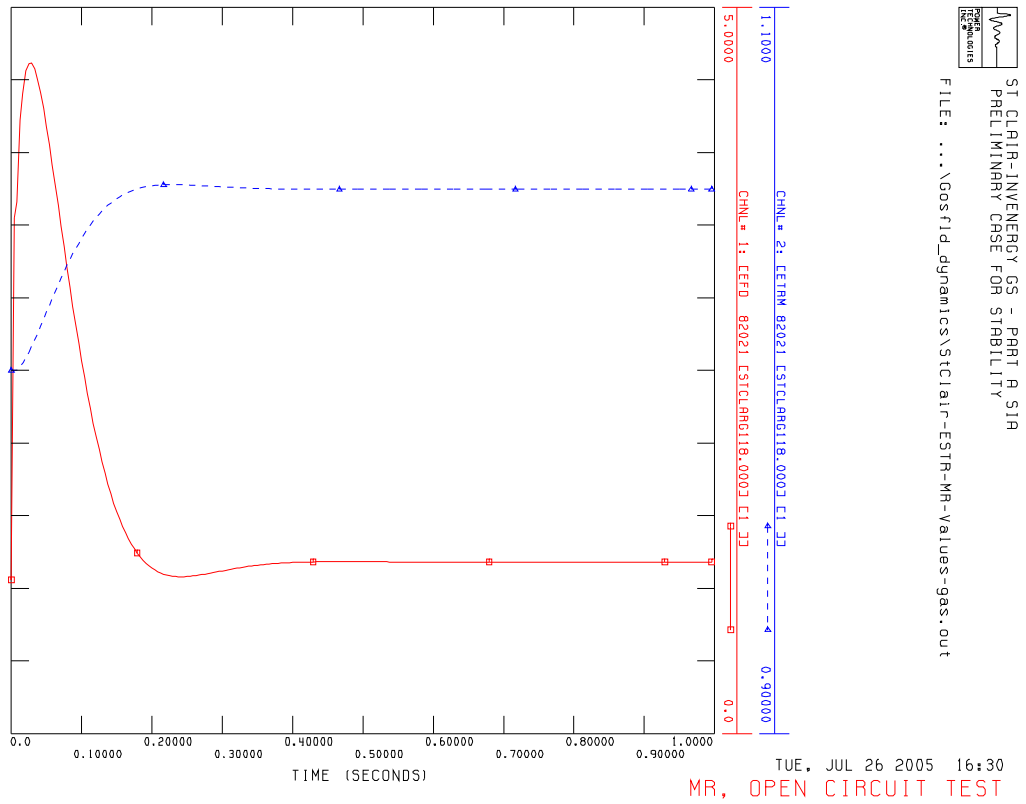

Figure 4: St. Clair – Gas-Fired Turbine Generator Open-Circuit Response

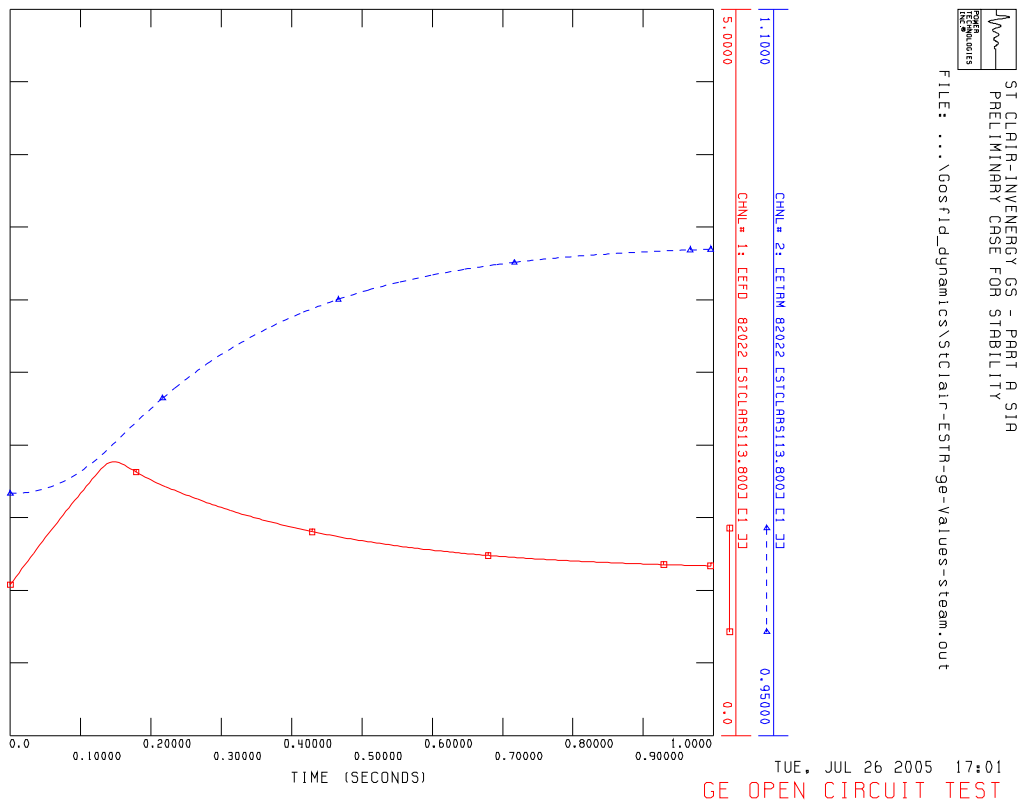

Figure 5: St. Clair – Steam Turbine Generator with Exciter Option A Open-Circuit Response

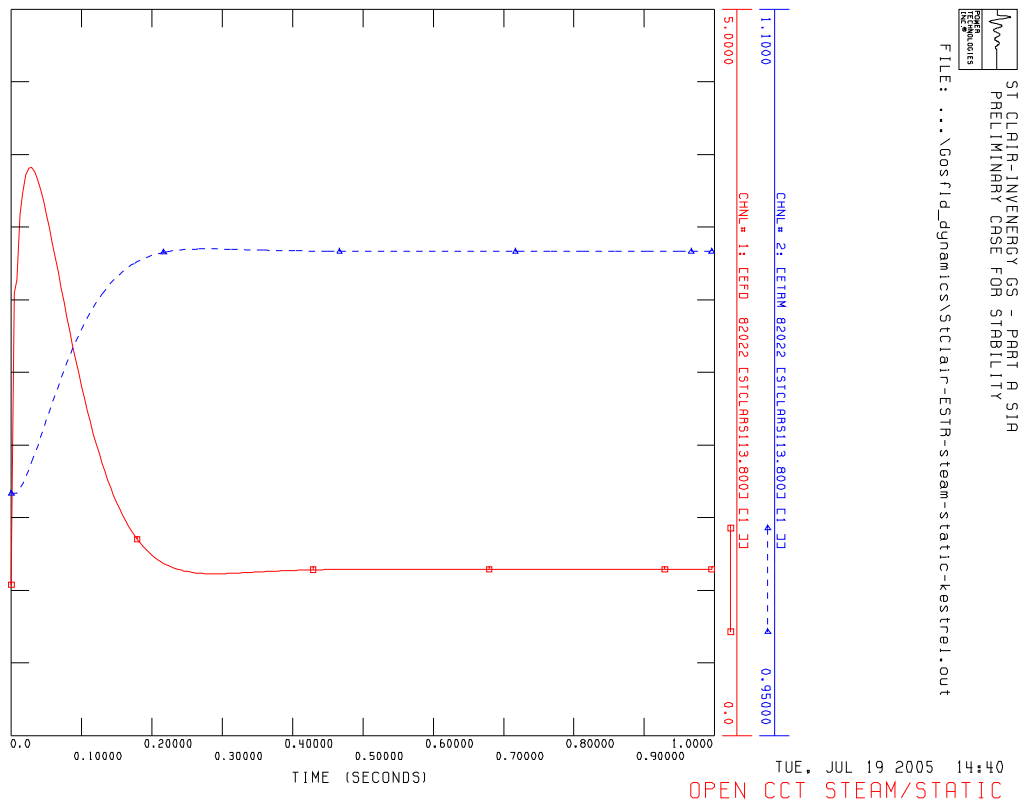

Figure 6: St. Clair – Steam Turbine Generator with Exciter Option B Open-Circuit Response

Power System Stabilizers

Data was provided for IEEE PSS2A model to represent the Power System Stabilizers that will be installed on the gas-fired turbine generators and steam turbine generator with option B. The data provided is shown in Table 25.

Table 25: St. Clair – PSS2A Data for Gas-Fired Turbine Generators and Steam Turbine Generators

| Description | Value | |
|-------------|------------------|--|
| | GTGs GTG3 & GTG4 | STGs STG3 & STG4 with exciter option B |
| IC1 | 1 | 1 |
| REMBUS1 | 0 | 0 |
| IC2 | 3 | 3 |
| REMBUS2 | 0 | 0 |
| M | 5 | 5 |
| N | 1 | 1 |
| Tw1 (>0) | 5 | 5 |
| Tw2 | 5 | 5 |
| T6 | 0 | 0 |
| Tw3 (>0) | 5 | 5 |
| Tw4 | 0 | 0 |
| T7 | 5 | 5 |
| KS2 | 0.833 | 0.488 |
| KS3 | 1 | 1 |
| T8 | 0.5 | 0.5 |
| T9 (>0) | 0.1 | 0.1 |
| KS1 | 10 | 10 |
| T1 | 0.15 | 0.15 |
| T2 | 0.03 | 0.03 |
| T3 | 0.15 | 0.15 |
| T4 | 0.03 | 0.03 |
| VSTMAX | 0.1 | 0.1 |
| VSTMIN | -0.1 | -0.05 |

It should be noted that the steam-turbine generators with exciter option B will be equipped with Power System Stabilizers represented by the IEEE model PSS2B. This model is a slight variation from the PSS2A model. The PSS2B model has an additional block to represent a third lead-lag function with time constants T11 and T12. These time constants are to be set to zero, therefore, allowing the use of the PSS2A model.

Governors

Typical data, as shown in Table 26, was provided for a GAST model to represent the governor to be installed on the gas-fired turbine generators.

Table 26: St. Clair – GAST Data for Gas-Fired Turbine Generators GTG3 & GTG4

| Description | Value |
|------------------------------------|-------|
| R (speed droop) | 0.05 |
| T1 (>0) (sec) | 0.4 |
| T2 (>0) (sec) | 0.1 |
| T3 (>0) (sec) | 3 |
| Ambient temperature load limit, AT | 1 |
| KT | 2 |
| VMAX | 1 |
| VMIN | -0.05 |
| Dturb | 0 |

Similarly, typical data was also provided for an IEESGO model to represent the governor to be installed on the steam turbine generators, as shown in Table 27.

Table 27: St. Clair – IEESGO Data for Steam Turbine Generators STG3 & STG4

| Description | Value |
|---|-------|
| T1, controller lag (sec) | 0 |
| T2, controller lead compensation(sec) | 0 |
| T3, governor lag (>0) (sec) | .1 |
| T4, delay due to steam inlet volumes associated with steam chest and inlet piping (sec) | .5 |
| T5, reheater delay including hot and cold leads (sec) | .2 |
| T6, delay due to IP-LP turbine, crossover pipes, and LP end hoods (sec) | 0.01 |
| K1 | 20. |
| K2 | 0.7 |
| K3 | 0 |
| PMAX | 1 |
| PMIN | 0.1 |

12.2 Transient Stability Results

Transient stability studies were performed for a high negative transfer condition across the BLIP (Buchanan Longwood Input) interface with various assumptions made on the number of Lambton, Greenfield and St. Clair units in service and the associated closed or ‘split’ operation of the Lambton and St. Clair 230 kV buses.

As a result, three case studies were studied with the following assumptions:

- Case 1: Greenfield, St. Clair and zero Lambton TGS units in service with the Greenfield 230 kV bus open and the St. Clair and Lambton 230 kV buses closed,
- Case 2: Greenfield, St. Clair and Lambton TGS units G3 & G4 in service with the Greenfield, St. Clair and Lambton 230 kV buses open, and
- Case 3: Greenfield, St. Clair and four Lambton TGS units in service with the Greenfield, St. Clair and Lambton 230 kV buses open.

For each case, the performance of the Greenfield and St. Clair generating units for the following fault conditions on the system were examined:

- Normally-cleared 3-phase fault on L25N at Lambton SS, and
- Normally-cleared LL-G fault on L23N and L25N at Lambton SS.

It should be noted that for these studies, only the static exciter (Option B) was used for the St. Clair STGs STG3 and STG4.

Results of Transient Stability Studies

The individual plot diagrams for the above cases are found in Appendix B.

The results from transient stability studies show that for all fault conditions examined the Greenfield and St. Clair generating units remained stable. In addition, the Lambton 230 kV bus voltages were restored to within 10% of their pre-contingency values within the 10 second simulation period.

For the St. Clair generators, the results show acceptable machine damping.

For the Greenfield generators, the results show poor machine damping with the exciter and stabilizer data provided by Greenfield. During commissioning, the Greenfield exciters and stabilizers must be tuned appropriately to provide better damping.

– End of Section –

Lambton 230 kV bus, North Switchyard (new diameter, closer to K1 bus)

Lambton 230 kV bus, South Switchyard (vacated L51D diameter position)

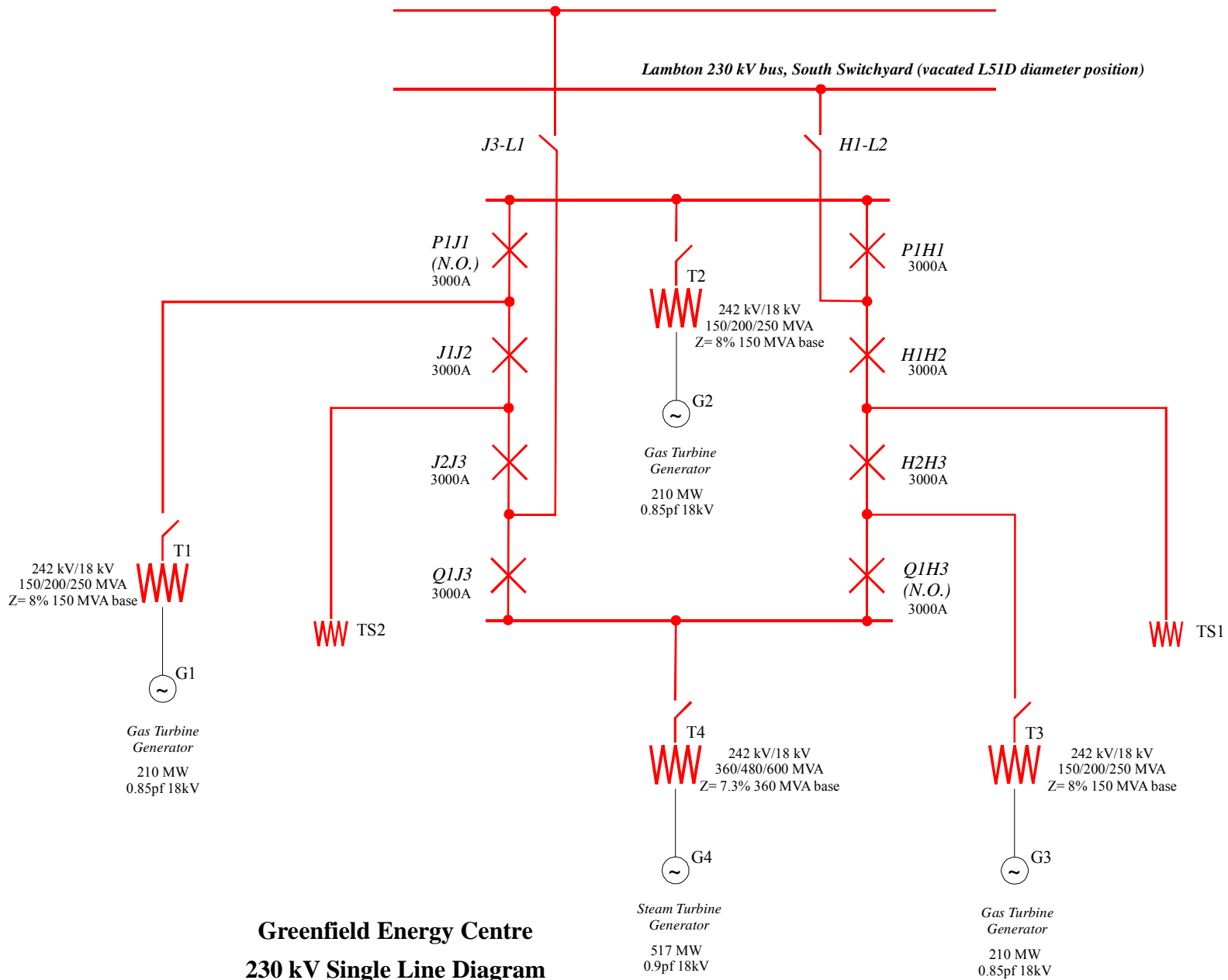

Greenfield Energy Centre
230 kV Single Line Diagram
1,147 MW

N.O. - Normally Open

DIAGRAM 1

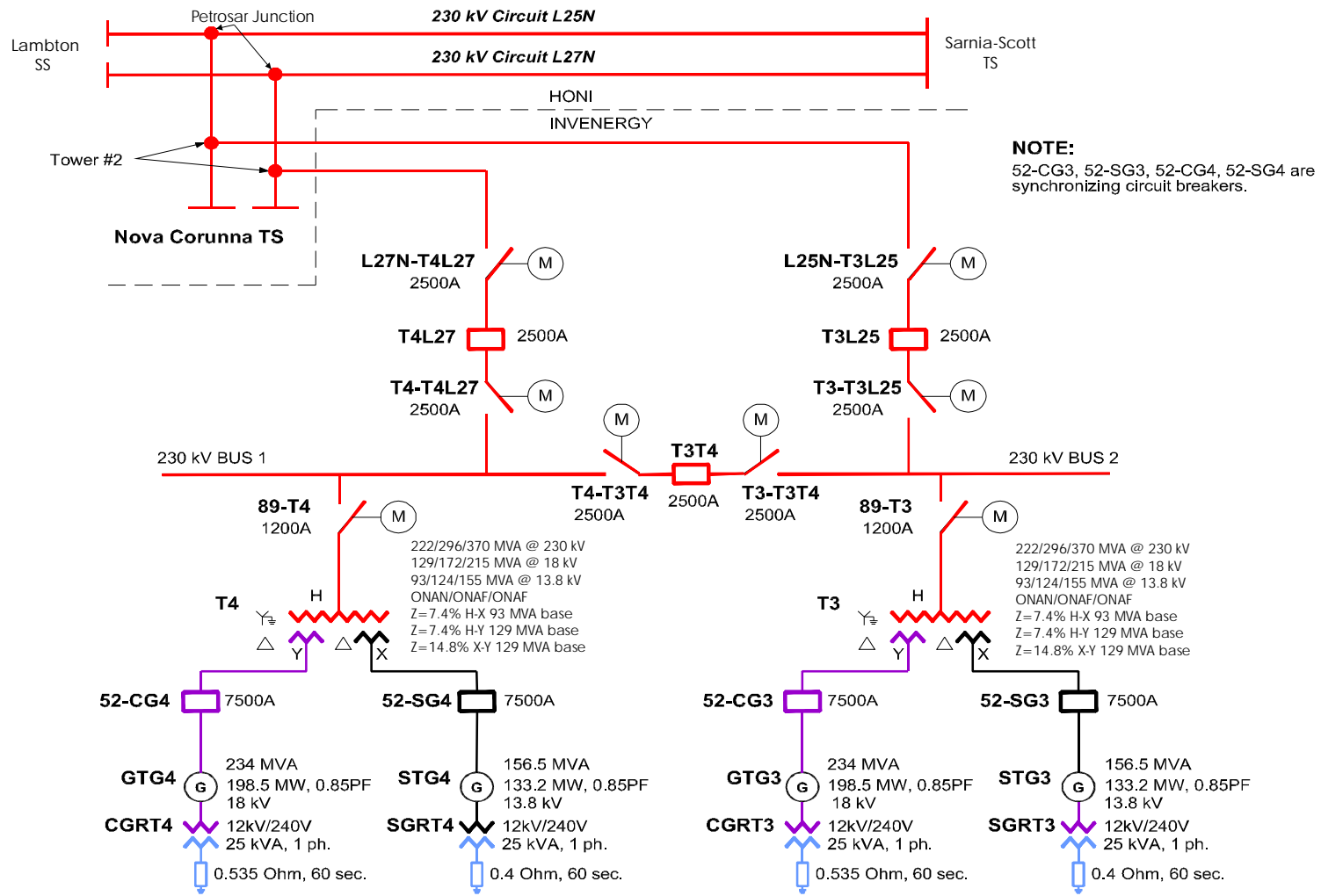

St. Clair Energy Centre
230 kV Single Line Diagram
638 MW

DIAGRAM 2

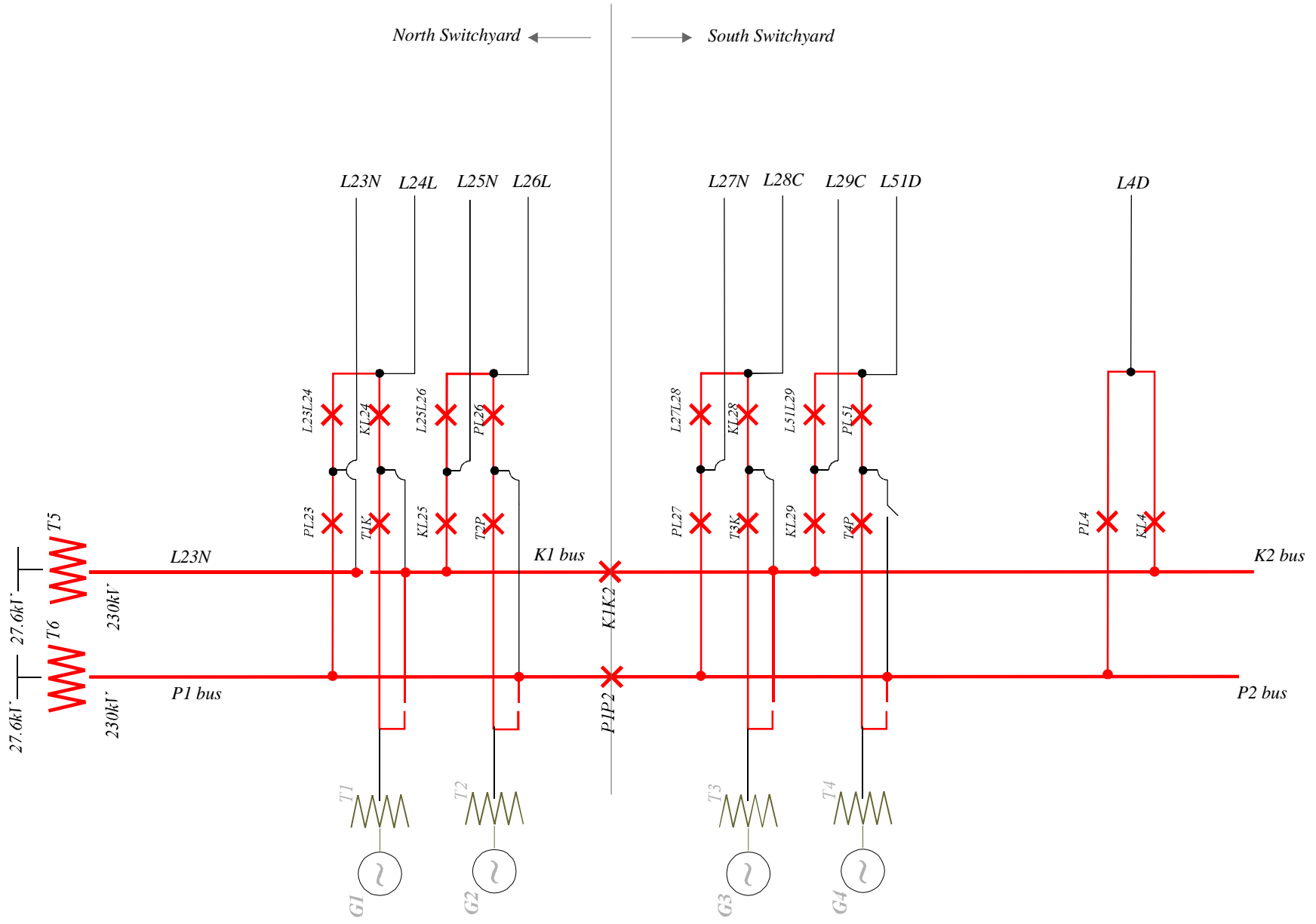

**Lambton SS - Existing
230kV Single Line Diagram**

DIAGRAM 3

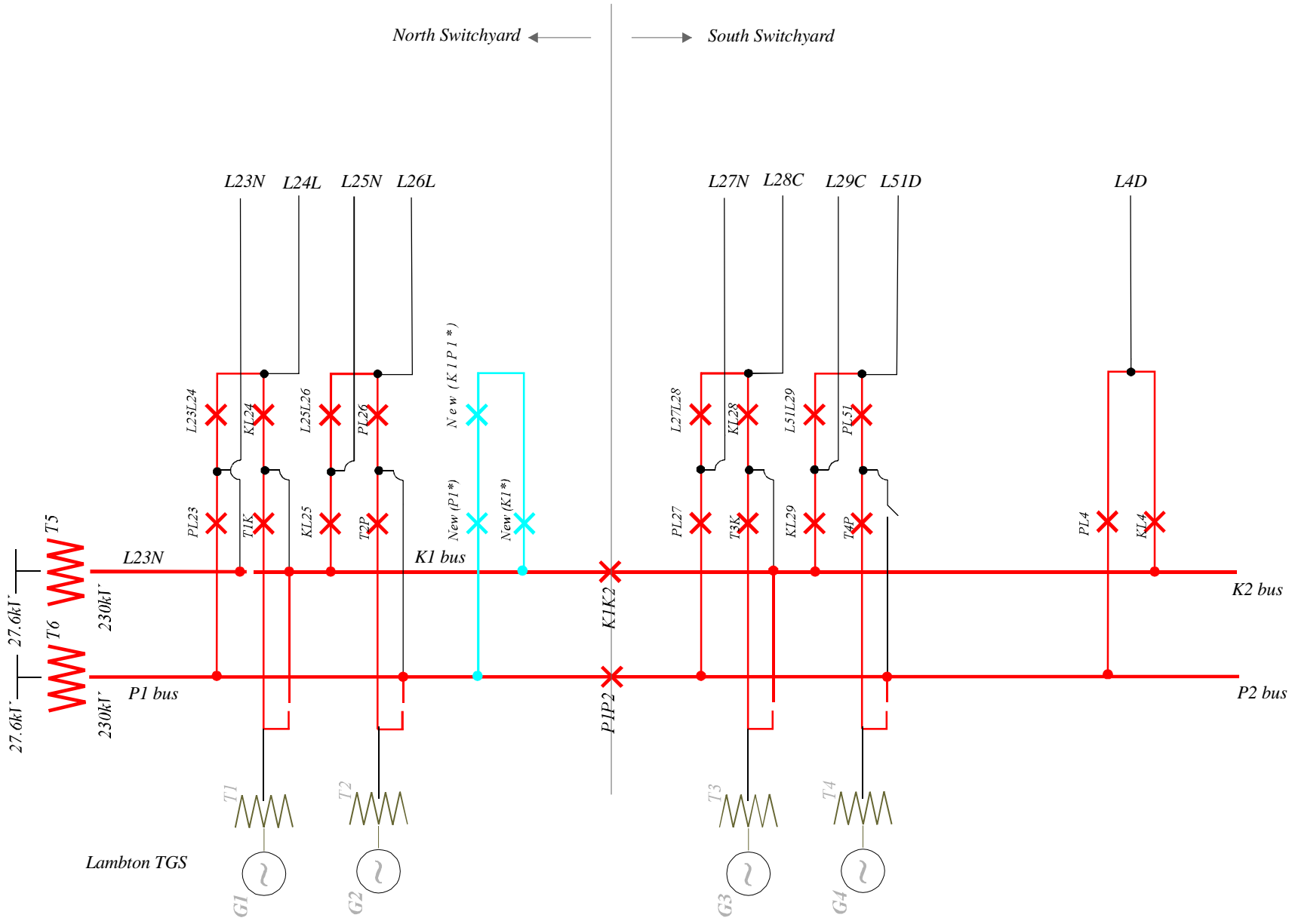

Lambton SS - New Diameter & Breakers - 230kV Single Line Diagram

DIAGRAM 4

- New
- Existing
- * Actual operating designation is to be determined by Hydro One

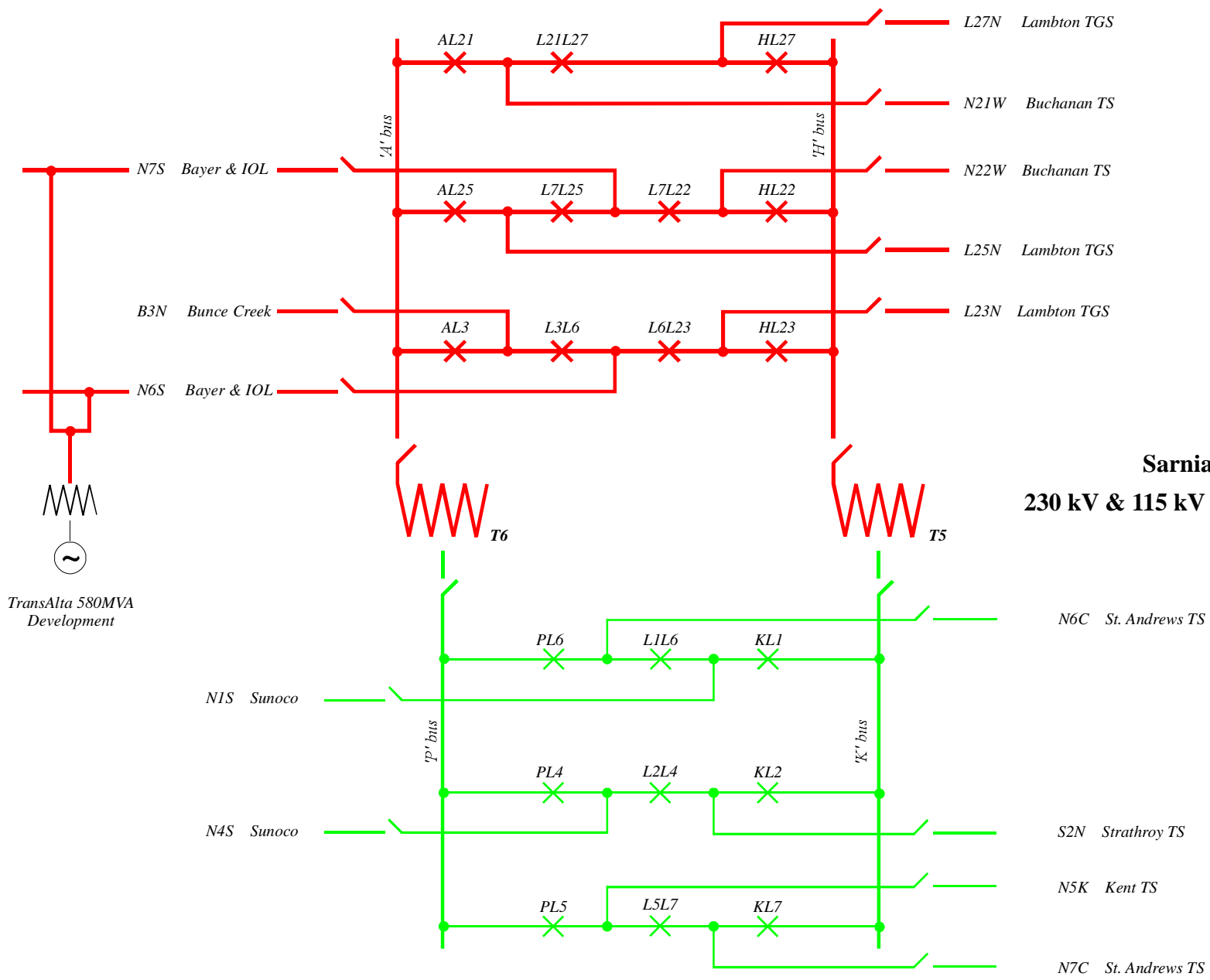

Sarnia-Scott TS
230 kV & 115 kV Single Line Diagram

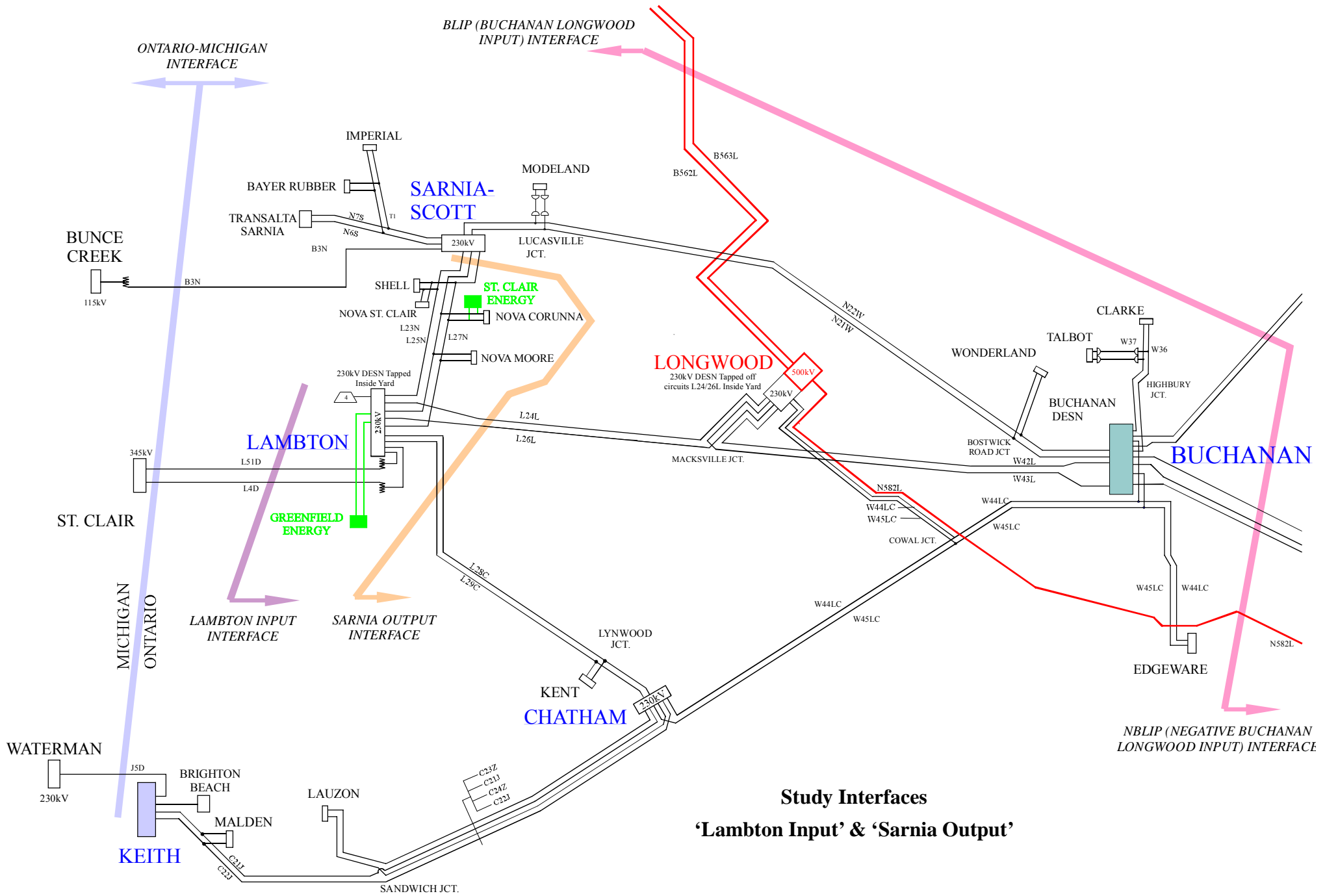

Study Interfaces
'Lambton Input' & 'Sarnia Output'

DIAGRAM 6

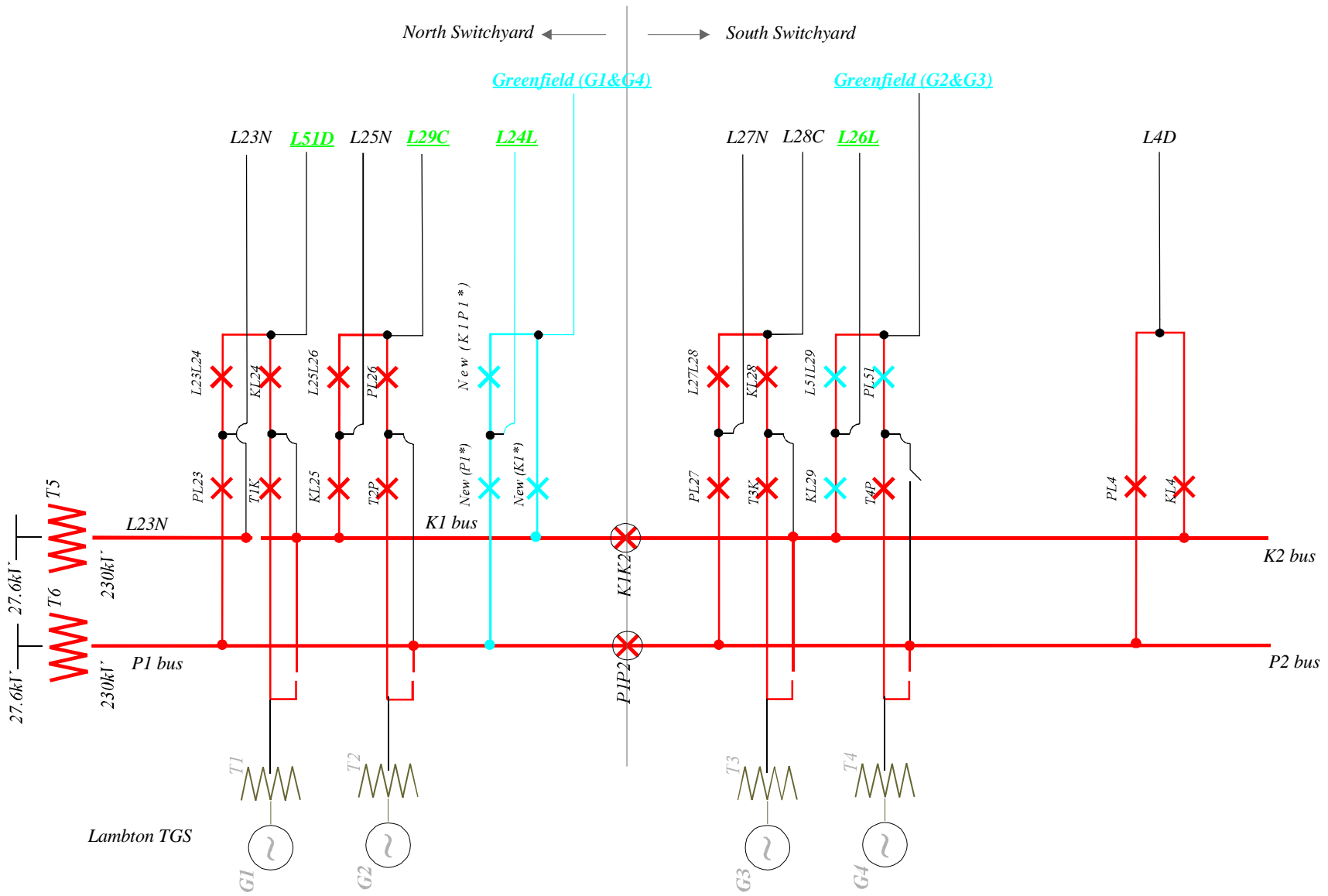

Lambton SS - 'Split' (Breakers K1K1 & P1P2 Open) and Reconfigured 230kV Single Line Diagram

— New
 — Existing
 — Reterminated
 * Actual operating design is to be determined by Hydro One

DIAGRAM 7

XYZ Status of individual breakers, derived from breaker pallet switches and the breaker trip module [OR gate]

+ Selection Contact for G/R, armed via SCADA

Transmitter }
Receiver } Transceiver

Functional Specification for the Lambton & Sarnia-Scott G/R Schemes

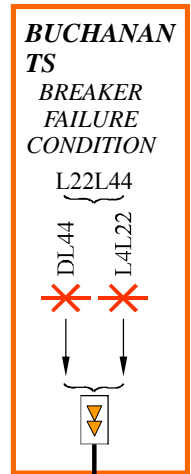
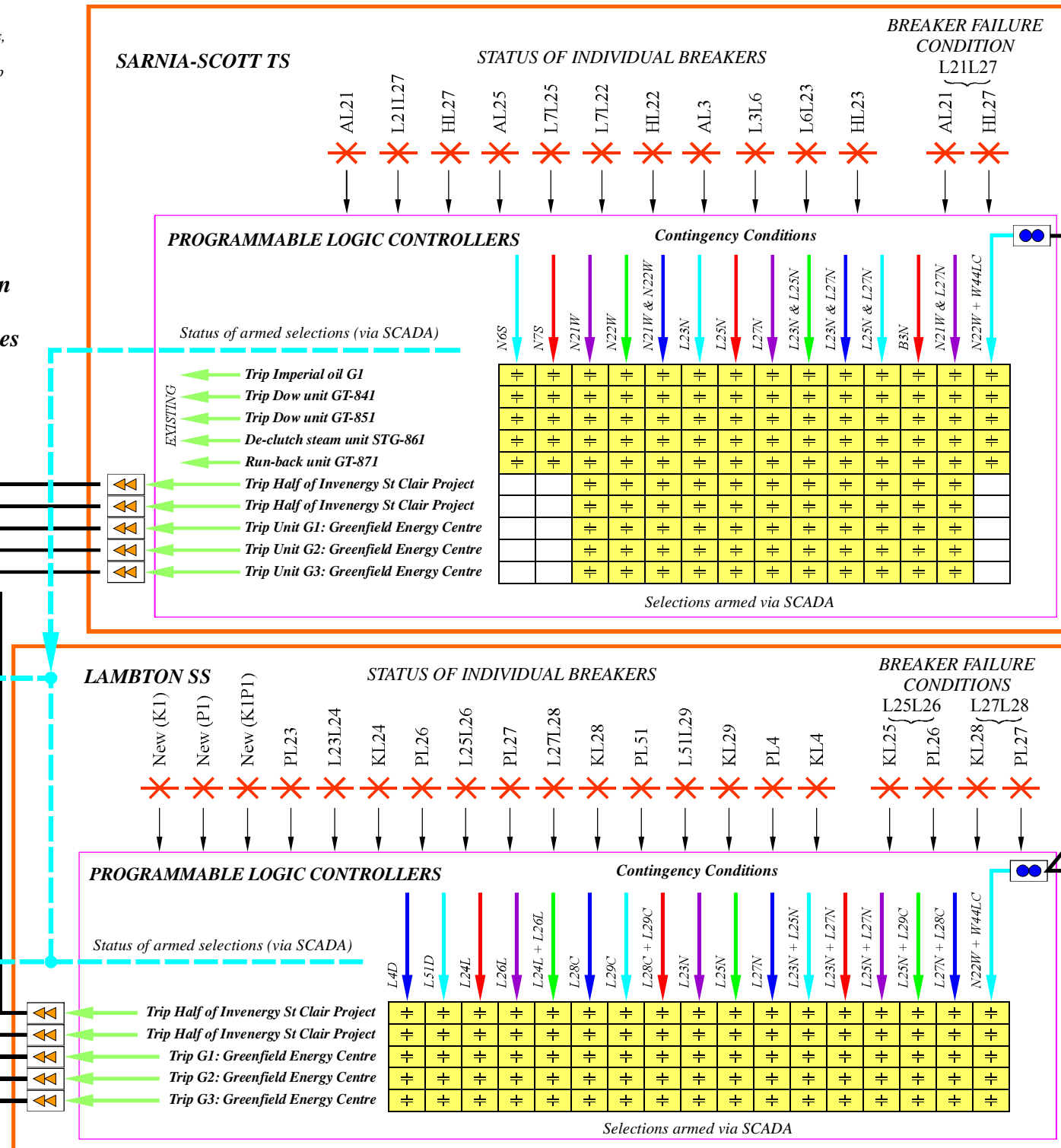
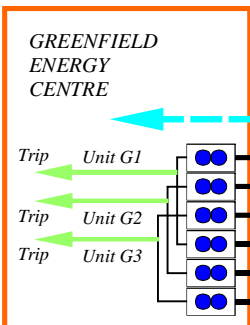
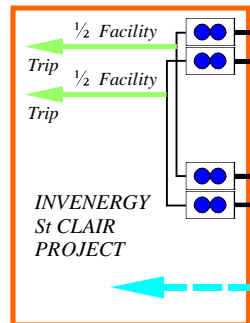

DIAGRAM 8

Appendix A: Results of Voltage Performance Studies

Case 1 – Loss of Greenfield G1 & G4 for System Condition ‘a’ (Lambton & St. Clair 230 kV buses closed, Greenfield G1 & G4 in service)

| Bus | Pre-contingency voltage (kV) | Voltage (kV) | | | |
|---------------------------|------------------------------|--------------|----------|-----------|----------|
| | | Pre-ULTC | % Change | Post-ULTC | % Change |
| Lambton 230 kV | 242.8 | 241.0 | -0.7 | 239.8 | -1.2 |
| Sarnia-Scott 230 kV | 242.0 | 240.0 | -0.8 | 238.9 | -1.3 |
| Sarnia-Scott 115 kV | 123 | 122 | -0.8 | 121 | -1.6 |
| Longwood 230 kV | 247.7 | 246.3 | -0.6 | 246.0 | -0.7 |
| Chatham 230 kV | 245.5 | 243.8 | -0.7 | 243.1 | -1.0 |
| Greenfield G1 & G4 230 kV | 243.0 | 241.0 | -0.8 | 239.8 | -1.3 |
| Greenfield G2 & G3 230 kV | 243.0 | 241.0 | -0.8 | 239.8 | -1.3 |
| St. Clair 230 kV | 242.2 | 240.3 | -0.8 | 239.2 | -1.2 |

Case 1A– Loss of new 230 kV double circuit line between Greenfield and Lambton for System Condition ‘a’ (Lambton & St. Clair 230 kV buses closed, Greenfield G1, G2, G3 & G4 in service)

| Bus | Pre-contingency voltage (kV) | Voltage (kV) | | | |
|---------------------------|------------------------------|--------------|----------|-----------|----------|
| | | Pre-ULTC | % Change | Post-ULTC | % Change |
| Lambton 230 kV | 243.0 | 239.7 | -1.4 | 237.9 | -2.1 |
| Sarnia-Scott 230 kV | 241.9 | 238.6 | -1.4 | 236.8 | -2.1 |
| Sarnia-Scott 115 kV | 123 | 121 | -1.6 | 120 | -2.4 |
| Longwood 230 kV | 246.7 | 244.2 | -1.0 | 243.6 | -1.3 |
| Chatham 230 kV | 245.0 | 242.2 | -1.1 | 241.0 | -1.6 |
| Greenfield G1 & G4 230 kV | 243.0 | 0 | | 0 | |
| Greenfield G2 & G3 230 kV | 243.2 | 0 | | 0 | |
| St. Clair 230 kV | 242.2 | 239.0 | -1.3 | 237.2 | -2.1 |

Case 2 – Loss of St. Clair GTG3 & STG3 for System Condition ‘a’ (Lambton & St. Clair 230 kV buses closed, St. Clair GTG3 & STG3 in service)

| Bus | Pre-contingency voltage (kV) | Voltage (kV) | | | |
|---------------------------|------------------------------|--------------|----------|-----------|----------|
| | | Pre-ULTC | % Change | Post-ULTC | % Change |
| Lambton 230 kV | 243.0 | 241.0 | -0.8 | 239.8 | -1.3 |
| Sarnia-Scott 230 kV | 242.5 | 240.0 | -1.0 | 238.9 | -1.5 |
| Sarnia-Scott 115 kV | 123 | 122 | -0.8 | 121 | -1.6 |
| Longwood 230 kV | 247.6 | 246.3 | -0.5 | 246.0 | -0.7 |
| Chatham 230 kV | 245.6 | 243.9 | -0.7 | 243.2 | -1.0 |
| Greenfield G1 & G4 230 kV | 243.0 | 241.0 | -0.8 | 239.8 | -1.0 |
| Greenfield G2 & G3 230 kV | 243.0 | 241.0 | -0.8 | 239.8 | -1.0 |
| St. Clair 230 kV | 242.0 | 240.3 | -0.7 | 239.2 | -1.2 |

Case 2A– Loss of 230 kV double circuit line L25N and L27N for System Condition ‘a’ (Lambton & St. Clair 230 kV buses closed, St. Clair GTG3, STG3, GTG4 & STG4 in service)

| Bus | Pre-contingency voltage (kV) | Voltage (kV) | | | |
|---------------------------|------------------------------|--------------|----------|-----------|----------|
| | | Pre-ULTC | % Change | Post-ULTC | % Change |
| Lambton 230 kV | 242.9 | 239.7 | -1.3 | 239.7 | -1.3 |
| Sarnia-Scott 230 kV | 242.6 | 237.1 | -2.3 | 237.1 | -2.3 |
| Sarnia-Scott 115 kV | 123 | 120 | -2.4 | 120 | -2.4 |
| Longwood 230 kV | 248.0 | 245.9 | -0.8 | 245.8 | -0.9 |
| Chatham 230 kV | 245.7 | 243.0 | -1.1 | 243.0 | -1.1 |
| Greenfield G1 & G4 230 kV | 242.9 | 239.7 | -1.3 | 239.7 | -1.3 |
| Greenfield G2 & G3 230 kV | 242.9 | 239.7 | -1.3 | 239.7 | -1.3 |

Case 3 – Loss of Greenfield G1 & G4 for System Condition ‘b’ (Lambton & St. Clair 230 kV buses closed, Greenfield G1 & G4 in service)

| Bus | Pre-contingency voltage (kV) | Voltage (kV) | | | |
|---------------------------|------------------------------|--------------|----------|-----------|----------|
| | | Pre-ULTC | % Change | Post-ULTC | % Change |
| Lambton 230 kV | 238.7 | 235.7 | -1.3 | 234.2 | -1.9 |
| Sarnia-Scott 230 kV | 236.4 | 234.0 | -1.0 | 232.8 | -1.5 |
| Sarnia-Scott 115 kV | 118 | 116 | -1.7 | 116 | -1.7 |
| Longwood 230 kV | 247.9 | 246.6 | -0.5 | 246.1 | -0.7 |
| Chatham 230 kV | 247.0 | 245.2 | -0.7 | 244.3 | -1.1 |
| Greenfield G1 & G4 230 kV | 239.0 | 235.7 | -1.4 | 234.2 | -2.0 |
| Greenfield G2 & G3 230 kV | 239.0 | 235.7 | -1.4 | 234.2 | -2.0 |
| St. Clair 230 kV | 237.2 | 234.5 | -1.1 | 233.2 | -1.7 |

Case 3A – Loss of new 230 kV double circuit line between Greenfield and Lambton for System Condition ‘b’ (Lambton & St. Clair 230 kV buses closed, Greenfield G1, G2, G3 & G4 in service)

| Bus | Pre-contingency voltage (kV) | Voltage (kV) | | | |
|---------------------------|------------------------------|--------------|----------|-----------|----------|
| | | Pre-ULTC | % Change | Post-ULTC | % Change |
| Lambton 230 kV | 238.6 | 231.8 | -2.8 | 222.1 | -6.9 |
| Sarnia-Scott 230 kV | 235.6 | 230.7 | -2.1 | 222.3 | -5.6 |
| Sarnia-Scott 115 kV | 117 | 115 | -1.7 | 111 | -5.1 |
| Longwood 230 kV | 246.6 | 244.9 | -0.7 | 242.4 | -1.7 |
| Chatham 230 kV | 245.8 | 242.3 | -1.4 | 236.9 | -3.6 |
| Greenfield G1 & G4 230 kV | 239.2 | 0 | | 0 | |
| Greenfield G2 & G3 230 kV | 239.2 | 0 | | 0 | |
| St. Clair 230 kV | 236.6 | 230.9 | -2.4 | 222.0 | -6.2 |

Case 4 – Loss of St. Clair GTG3 & STG3 for System Condition ‘b’ (Lambton & St. Clair 230 kV buses closed, St. Clair GTG3 & STG3 in service)

| Bus | Pre-contingency voltage (kV) | Voltage (kV) | | | |
|---------------------------|------------------------------|--------------|----------|-----------|----------|
| | | Pre-ULTC | % Change | Post-ULTC | % Change |
| Lambton 230 kV | 238.4 | 236.1 | -1.0 | 234.7 | -1.6 |
| Sarnia-Scott 230 kV | 236.9 | 234.4 | -1.1 | 233.3 | -1.5 |
| Sarnia-Scott 115 kV | 118 | 117 | -0.8 | 116 | -1.7 |
| Longwood 230 kV | 247.4 | 246.7 | -0.3 | 246.3 | -0.4 |
| Chatham 230 kV | 247.0 | 245.5 | -0.6 | 244.7 | -0.9 |
| Greenfield G1 & G4 230 kV | 238.4 | 236.1 | -1.0 | 234.7 | -1.6 |
| Greenfield G2 & G3 230 kV | 238.4 | 236.1 | -1.0 | 234.7 | -1.6 |
| St. Clair 230 kV | 238.1 | 234.9 | -1.3 | 233.7 | -1.8 |

Case 4A– Loss of 230 kV double circuit line L25N and L27N for System Condition ‘b’ (Lambton & St. Clair 230 kV buses closed, St. Clair GTG3, STG3, GTG4 & STG4 in service)

| Bus | Pre-contingency voltage (kV) | Voltage (kV) | | | |
|---------------------------|------------------------------|--------------|----------|-----------|----------|
| | | Pre-ULTC | % Change | Post-ULTC | % Change |
| Lambton 230 kV | 239.9 | 236.4 | -1.5 | 233.2 | -2.8 |
| Sarnia-Scott 230 kV | 238.2 | 232.5 | -2.4 | 230.7 | -3.1 |
| Sarnia-Scott 115 kV | 119 | 116 | -2.5 | 115 | -3.4 |
| Longwood 230 kV | 247.7 | 246.3 | -0.6 | 245.4 | -0.9 |
| Chatham 230 kV | 247.5 | 244.9 | -1.1 | 243.0 | -1.8 |
| Greenfield G1 & G4 230 kV | 239.9 | 236.4 | -1.5 | 233.2 | -2.8 |
| Greenfield G2 & G3 230 kV | 239.9 | 236.4 | -1.5 | 233.2 | -2.8 |
| St. Clair 230 kV | 239.9 | 0 | | 0 | |

Case 5 – Loss of Greenfield G1 & G4 for System Condition ‘b’ (Lambton & St. Clair 230 kV buses open, Greenfield G1 & G4 in service)

| Bus | Pre-contingency voltage (kV) | Voltage (kV) | | | |
|---------------------------------|------------------------------|--------------|----------|-----------|----------|
| | | Pre-ULTC | % Change | Post-ULTC | % Change |
| Lambton 230 kV north switchyard | 239.1 | 236.7 | -1.0 | 234.5 | -2.0 |
| Lambton 230 kV south switchyard | 246.3 | 245.6 | -0.3 | 244.8 | -0.6 |
| Sarnia-Scott 230 kV | 237.7 | 236.2 | -0.6 | 234.9 | -1.2 |
| Sarnia-Scott 115 kV | 118 | 118 | 0 | 117 | -0.8 |
| Longwood 230 kV | 247.1 | 246.6 | -0.2 | 246.2 | -0.4 |
| Chatham 230 kV | 247.3 | 246.3 | -0.4 | 245.4 | -0.8 |
| Greenfield G1 & G4 230 kV | 239.6 | 236.7 | -1.2 | 234.5 | -2.1 |
| Greenfield G2 & G3 230 kV | 246.2 | 245.6 | -0.2 | 244.8 | -0.6 |
| St. Clair GTG3 & STG3 230 kV | 238.2 | 236.4 | -0.8 | 234.7 | -1.5 |
| St. Clair GTG4 & STG4 230 kV | 240.7 | 239.6 | -0.5 | 238.4 | -1.0 |

Case 5A – Loss of new 230 kV double circuit line between Greenfield and Lambton for System Condition ‘b’ (Lambton & St. Clair 230 kV buses open, Greenfield G1, G2, G3 & G4 in service)

| Bus | Pre-contingency voltage (kV) | Voltage (kV) | | | |
|---------------------------------|------------------------------|--------------|----------|-----------|----------|
| | | Pre-ULTC | % Change | Post-ULTC | % Change |
| Lambton 230 kV north switchyard | 237.2 | 229.9 | -3.1 | 216.0 | -8.9 |
| Lambton 230 kV south switchyard | 244.5 | 239.2 | -2.2 | 229.9 | -6.0 |
| Sarnia-Scott 230 kV | 235.3 | 230.4 | -2.1 | 219.4 | -6.8 |
| Sarnia-Scott 115 kV | 117 | 115 | -1.7 | 109 | -6.8 |
| Longwood 230 kV | 246.6 | 244.9 | -0.7 | 241.6 | -2.0 |
| Chatham 230 kV | 244.7 | 241.2 | -1.4 | 234.6 | -4.1 |
| Greenfield G1 & G4 230 kV | 238.1 | 0 | | 0 | |
| Greenfield G2 & G3 230 kV | 244.5 | 0 | | 0 | |
| St. Clair GTG3 & STG3 230 kV | 236.0 | 230.1 | -2.5 | 217.9 | -7.7 |
| St. Clair GTG4 & STG4 230 kV | 238.6 | 233.3 | -2.2 | 222.9 | -6.6 |

Case 6 – Loss of St. Clair GTG3 & STG3 for System Condition ‘b’ (Lambton & St. Clair 230 kV buses open, St. Clair GTG3 & STG3 in service)

| Bus | Pre-contingency voltage (kV) | Voltage (kV) | | | |
|---------------------------------|------------------------------|--------------|----------|-----------|----------|
| | | Pre-ULTC | % Change | Post-ULTC | % Change |
| Lambton 230 kV north switchyard | 240.1 | 238.0 | -0.9 | 235.7 | -1.8 |
| Lambton 230 kV south switchyard | 247.1 | 246.1 | -0.4 | 245.3 | -0.7 |
| Sarnia-Scott 230 kV | 239.1 | 237.2 | -0.8 | 235.7 | -1.4 |
| Sarnia-Scott 115 kV | 119 | 118 | -0.8 | 117 | -1.7 |
| Longwood 230 kV | 247.6 | 247.0 | -0.2 | 246.5 | -0.4 |
| Chatham 230 kV | 248.1 | 247.0 | -0.4 | 246.0 | -0.8 |
| Greenfield G1 & G4 230 kV | 240.1 | 238.0 | -0.9 | 235.7 | -1.8 |
| Greenfield G2 & G3 230 kV | 247.1 | 246.1 | -0.4 | 245.3 | -0.7 |
| St. Clair GTG3 & STG3 230 kV | 240.5 | 237.5 | -1.2 | 235.7 | -2.0 |
| St. Clair GTG4 & STG4 230 kV | 242.0 | 240.4 | -0.7 | 239.2 | -1.2 |

Case 6A – Loss of 230 kV double circuit line L25N and L27N for System Condition ‘b’ (Lambton & St. Clair 230 kV buses open, St. Clair GTG3, STG3, GTG4 & STG4 in service)

| Bus | Pre-contingency voltage (kV) | Voltage (kV) | | | |
|---------------------------------|------------------------------|--------------|----------|-----------|----------|
| | | Pre-ULTC | % Change | Post-ULTC | % Change |
| Lambton 230 kV north switchyard | 238.5 | 230.9 | -3.2 | 216.9 | -9.1 |
| Lambton 230 kV south switchyard | 246.5 | 247.2 | 0.3 | 245.5 | -0.4 |
| Sarnia-Scott 230 kV | 237.9 | 229.4 | -3.6 | 219.4 | -7.8 |
| Sarnia-Scott 115 kV | 119 | 114 | -4.2 | 109 | -8.4 |
| Longwood 230 kV | 245.1 | 243.1 | -0.8 | 240.6 | -1.8 |
| Chatham 230 kV | 246.4 | 242.8 | -1.5 | 237.9 | -3.4 |
| Greenfield G1 & G4 230 kV | 238.5 | 230.9 | -3.2 | 216.9 | -9.1 |
| Greenfield G2 & G3 230 kV | 246.5 | 247.2 | 0.3 | 245.5 | -0.4 |
| St. Clair GTG3 & STG3 230 kV | 239.4 | 0 | | 0 | |
| St. Clair GTG3 & STG3 230 kV | 241.9 | 0 | | 0 | |

– End of Section –

Appendix B: Results of Transient Stability Studies

Case 1 – L25N 3-phase fault – Greenfield generators G1, G2, G3 & G4



2010 JULY CASE----- 8_8B6P4D4NOLK2BKOLB2LX16SD2OS
 -530BLIP6904FABC2994FETT1765QFW-604MICH-1138NYNI-250NYSL-14

FILE: case1_L25N_3pfault.out

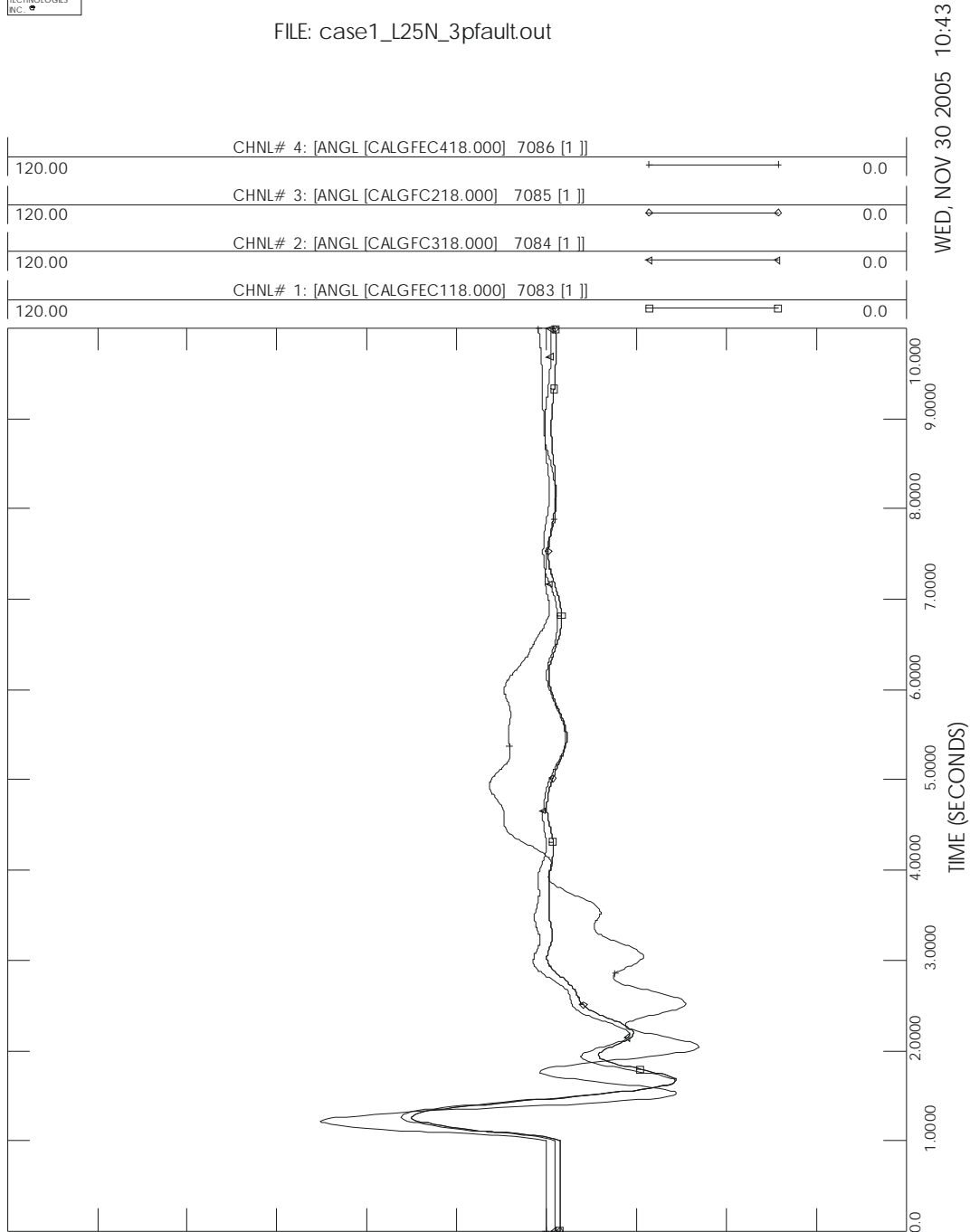

Case 1 – L25N 3-phase fault – St. Clair generators GTG3, GTG4, STG3 & STG4



2010 JULY CASE----- 8_8B6P4D4NOLK2BKOLB2LX16SD2OS
 -530BLIP6904FABC2994FETT1765QFW-604MICH-1138NYNI-250NYSL-14

FILE: case1_L25N_3pfault.out

WED, NOV 30 2005 10:43

| | | | |
|--------|--|---|-----|
| 100.00 | CHNL# 8: [ANGL [INVSCSG213.800] 7098 [1]] | ↔ | 0.0 |
| 100.00 | CHNL# 7: [ANGL [INVSCG2 18.000] 7097 [1]] | ◊ | 0.0 |
| 100.00 | CHNL# 6: [ANGL [INVSCSG113.800] 7096 [1]] | ← | 0.0 |
| 100.00 | CHNL# 5: [ANGL [INVSCG1 18.000] 7095 [1]] | ◻ | 0.0 |

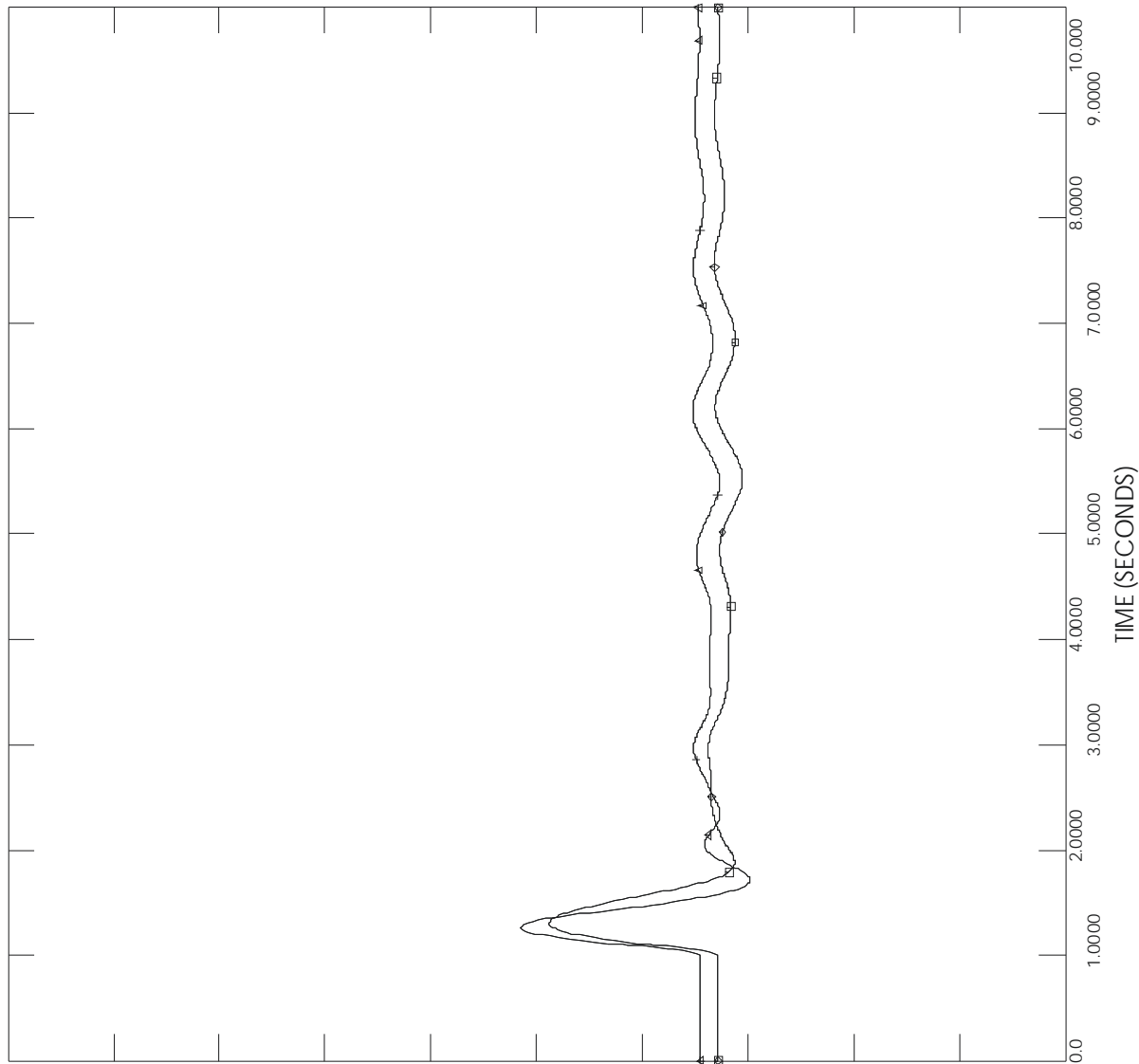

Case 1 – L25N 3-phase fault – Lambton 230 kV Bus Voltage



2010 JULY CASE----- 8_8B6P4D4NOLK2BK0LB2LX16SD2OS
-530BLIP6904FABC2994FETT1765QFW-604MICH-1138NYNI-250NYSL-14

FILE: case1_L25N_3pfault.out

WED, NOV 30 2005 10:43

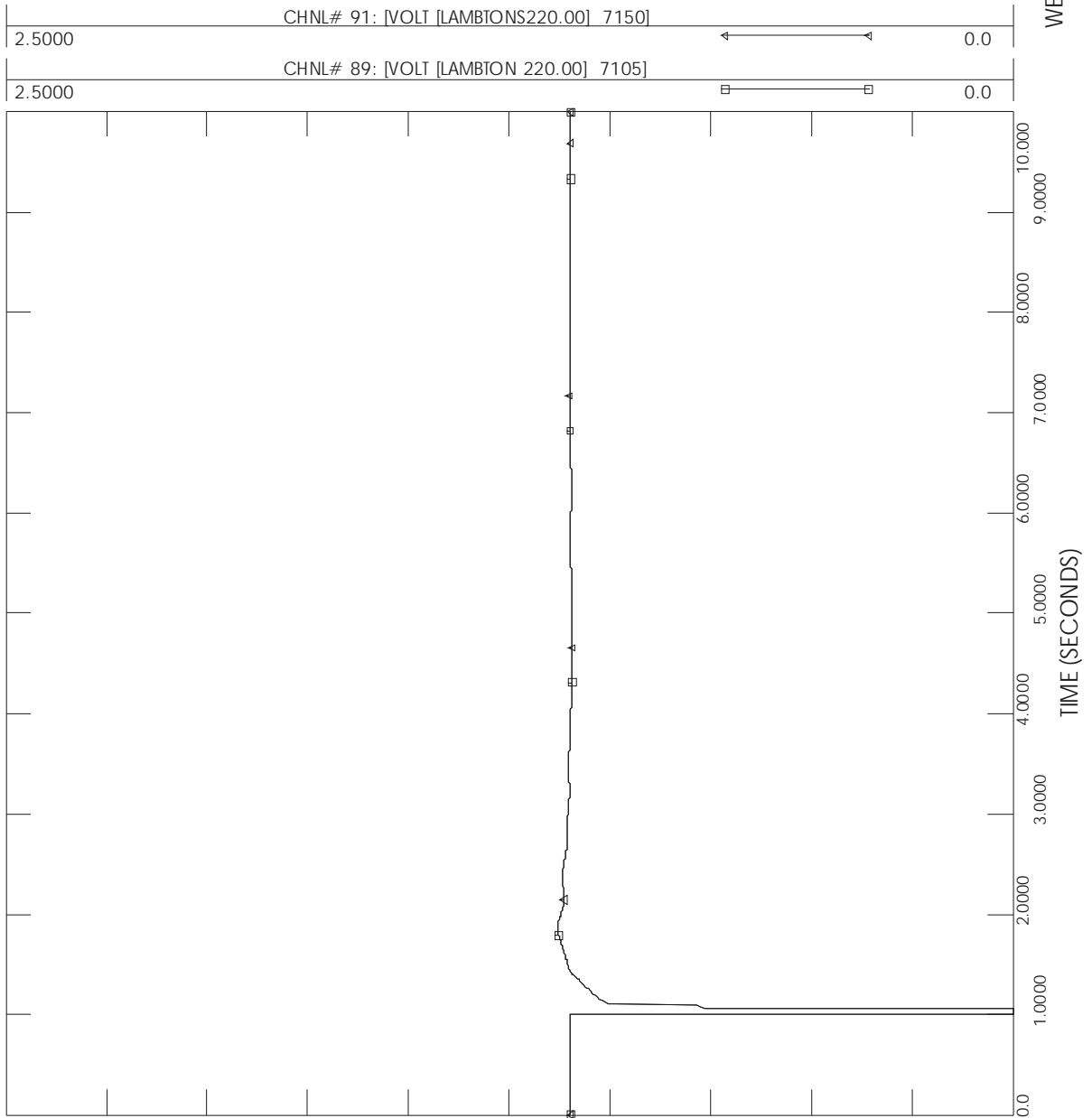

Case 1 – L25N/L25N LL-G fault – Greenfield generators G1, G2, G3 & G4



2010 JULY CASE----- 8_8B6P4D4NOLK2BK0LB2LX16SD2OS
 -530BLIP6904FABC2994FETT1765QFW-604MICH-1138NYNI-250NYSL-14

FILE: case1_L23N_L25N_LLgfault.out

WED, NOV 30 2005 10:43

| | | | |
|--------|--|---|-----|
| 120.00 | CHNL# 4: [ANGL [CALGFEC418.000] 7086 [1]] | ↔ | 0.0 |
| 120.00 | CHNL# 3: [ANGL [CALGFEC218.000] 7085 [1]] | ◊ | 0.0 |
| 120.00 | CHNL# 2: [ANGL [CALGFEC318.000] 7084 [1]] | ← | 0.0 |
| 120.00 | CHNL# 1: [ANGL [CALGFEC118.000] 7083 [1]] | ◻ | 0.0 |

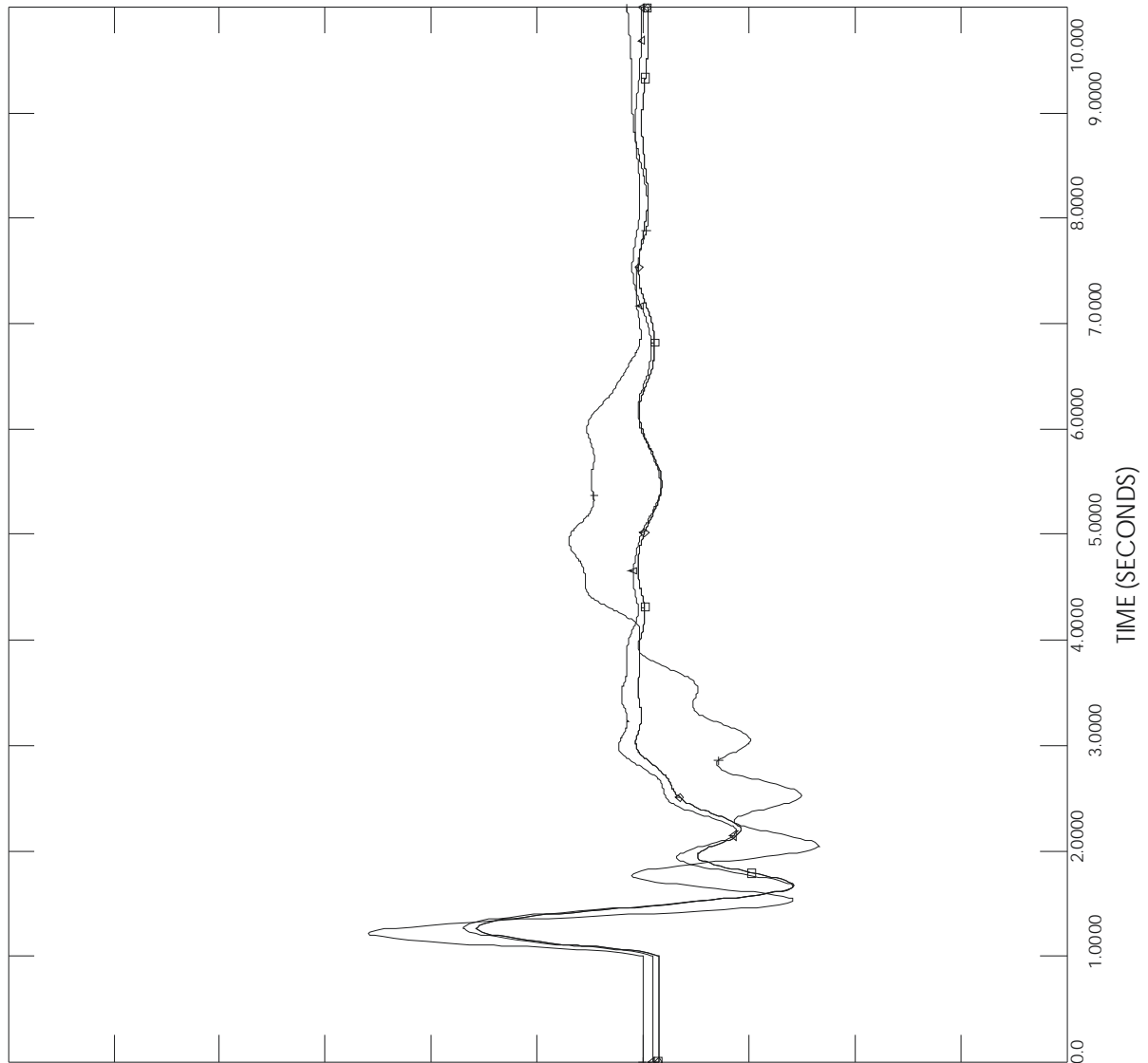

Case 1 – L23N/L25N LL-G fault – St. Clair generators GTG3, GTG4, STG3 & STG4



2010 JULY CASE----- 8_8B6P4D4NOLK2BKOLB2LX16SD2OS
 -530BLIP6904FABC2994FETT1765QFW-604MICH-1138NYNI-250NYSL-14

FILE: case1_L23N_L25N_LLGfault.out

| | | | | |
|--------|--|---|---|-----|
| 100.00 | CHNL# 8: [ANGL [INVSCSG213.800] 7098 [1]] | + | + | 0.0 |
| 100.00 | CHNL# 7: [ANGL [INVSCG2 18.000] 7097 [1]] | ◇ | ◇ | 0.0 |
| 100.00 | CHNL# 6: [ANGL [INVSCSG113.800] 7096 [1]] | ← | → | 0.0 |
| 100.00 | CHNL# 5: [ANGL [INVSCG1 18.000] 7095 [1]] | □ | □ | 0.0 |

WED, NOV 30 2005 10:43

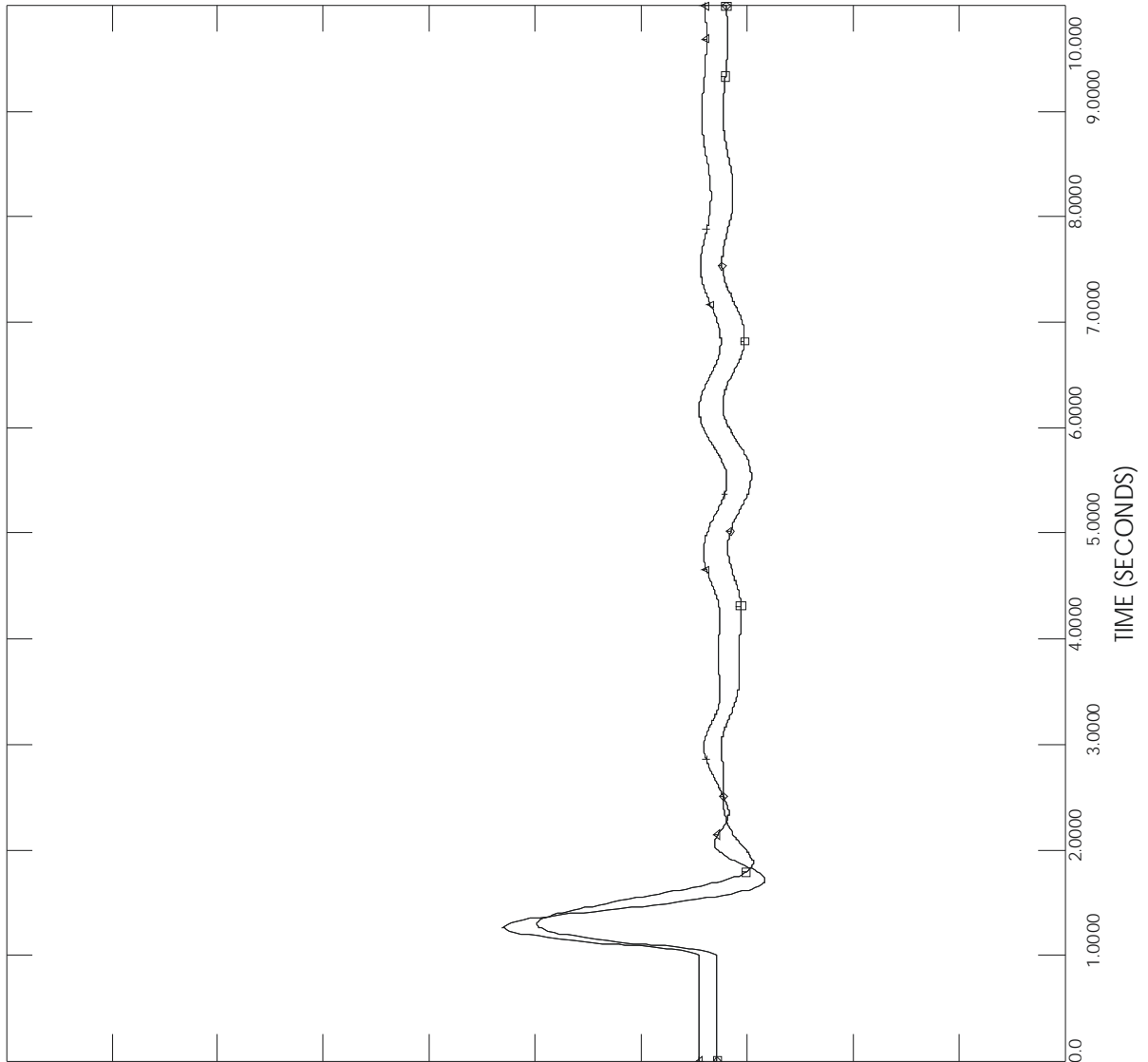

Case 1 – L23N/L25N LL-G fault – Lambton 230 kV Bus Voltage



2010 JULY CASE----- 8_8B6P4D4NOLK2BK0LB2LX16SD2OS
-530BLIP6904FABC2994FETT1765QFW-604MICH-1138NYNI-250NYSL-14

FILE: case1_L23N_L25N_LLgfault.out

WED, NOV 30 2005 10:43

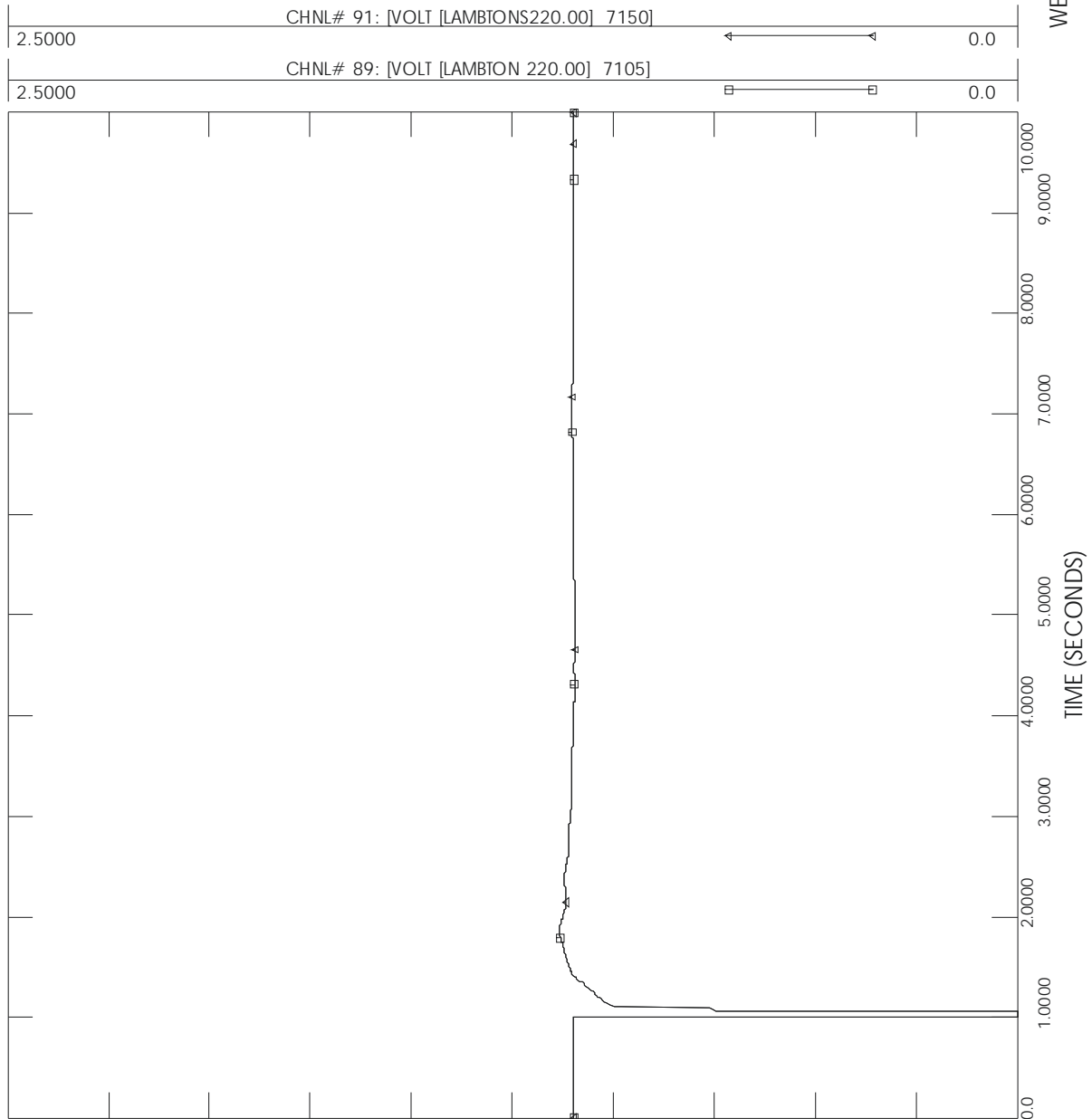

Case 2 – L25N 3-phase fault – Greenfield generators G1, G2, G3 & G4



2010 JULY CASE----- 8_8B6P4D4NOLK2BKOLB2LX16SD2OS
 -530BLIP6904FABC2994FETT1765QFW-604MICH-1138NYNI-250NYSL-14

FILE: case2_L25N_3pfault.out

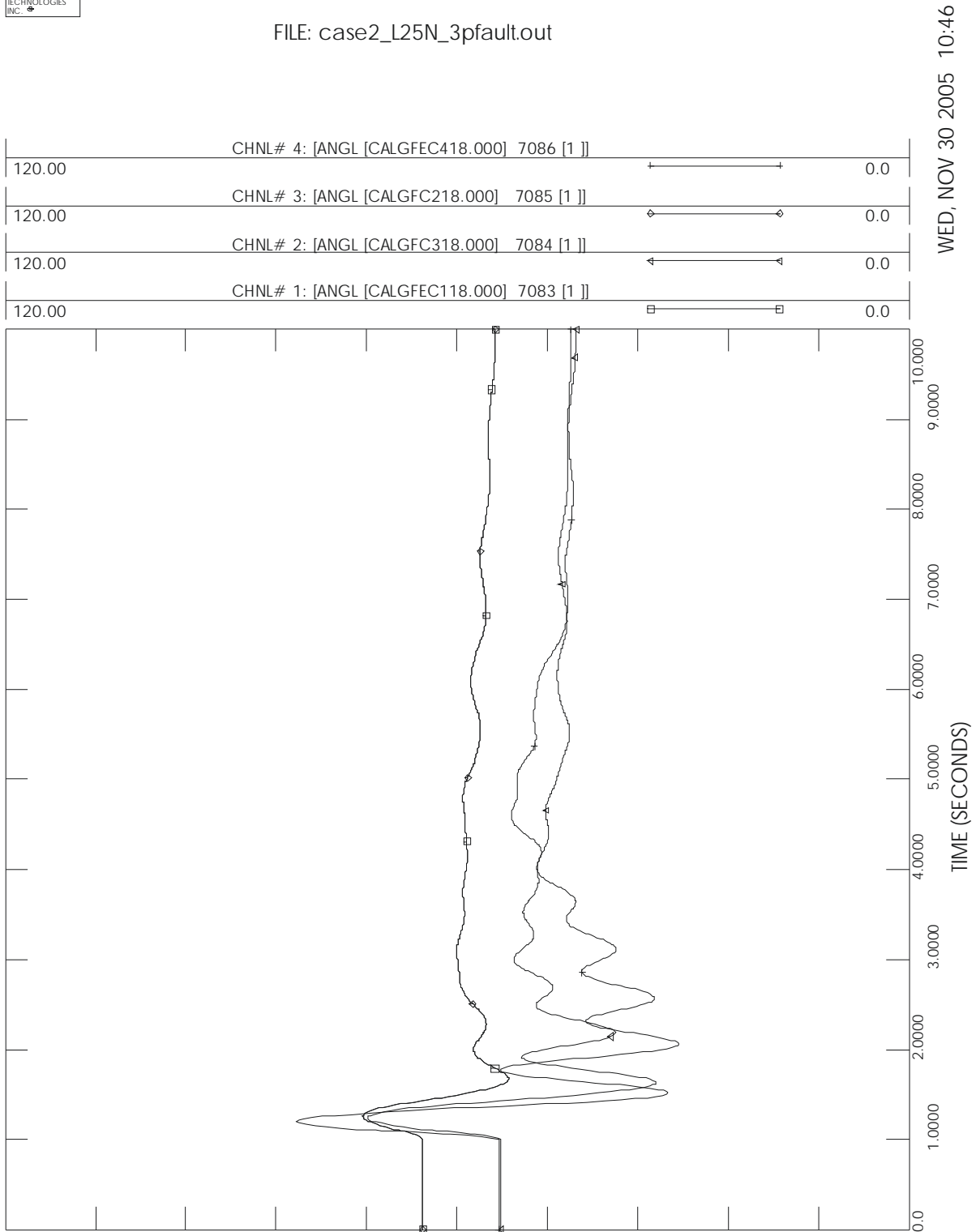

Case 2 – L25N 3-phase fault – St. Clair generators GTG3, GTG4, STG3 & STG4



2010 JULY CASE----- 8_8B6P4D4NOLK2BK0LB2LX16SD2OS
 -530BLIP6904FABC2994FETT1765QFW-604MICH-1138NYNI-250NYSL-14

FILE: case2_L25N_3pfault.out

WED, NOV 30 2005 10:46

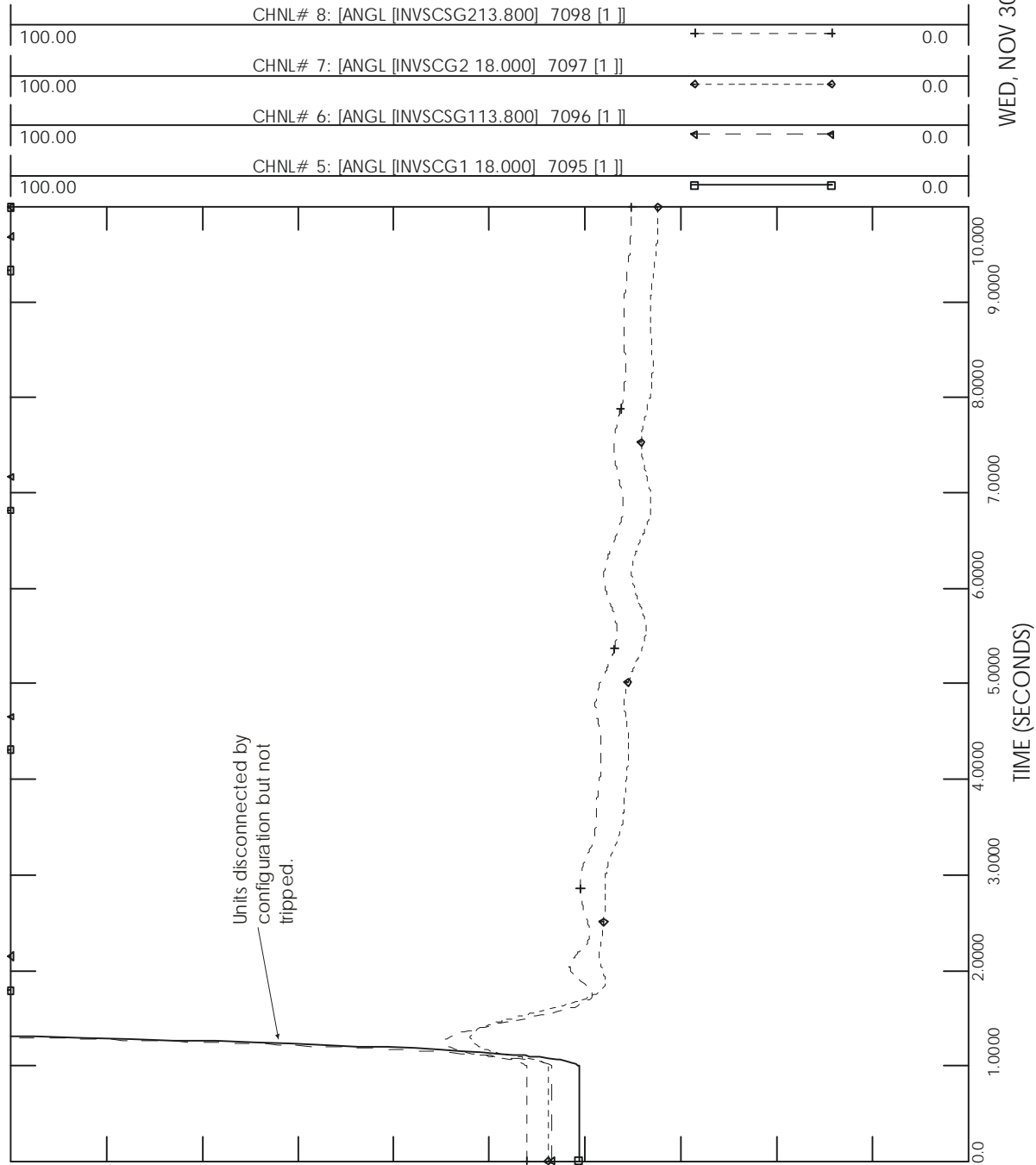

Case 2 – L25N 3-phase fault – Lambton 230 kV Bus Voltage



2010 JULY CASE----- 8_8B6P4D4NOLK2BK0LB2LX16SD2OS
-530BLIP6904FABC2994FETT1765QFW-604MICH-1138NYNI-250NYSL-14

FILE: case2_L25N_3pfault.out

WED, NOV 30 2005 10:45

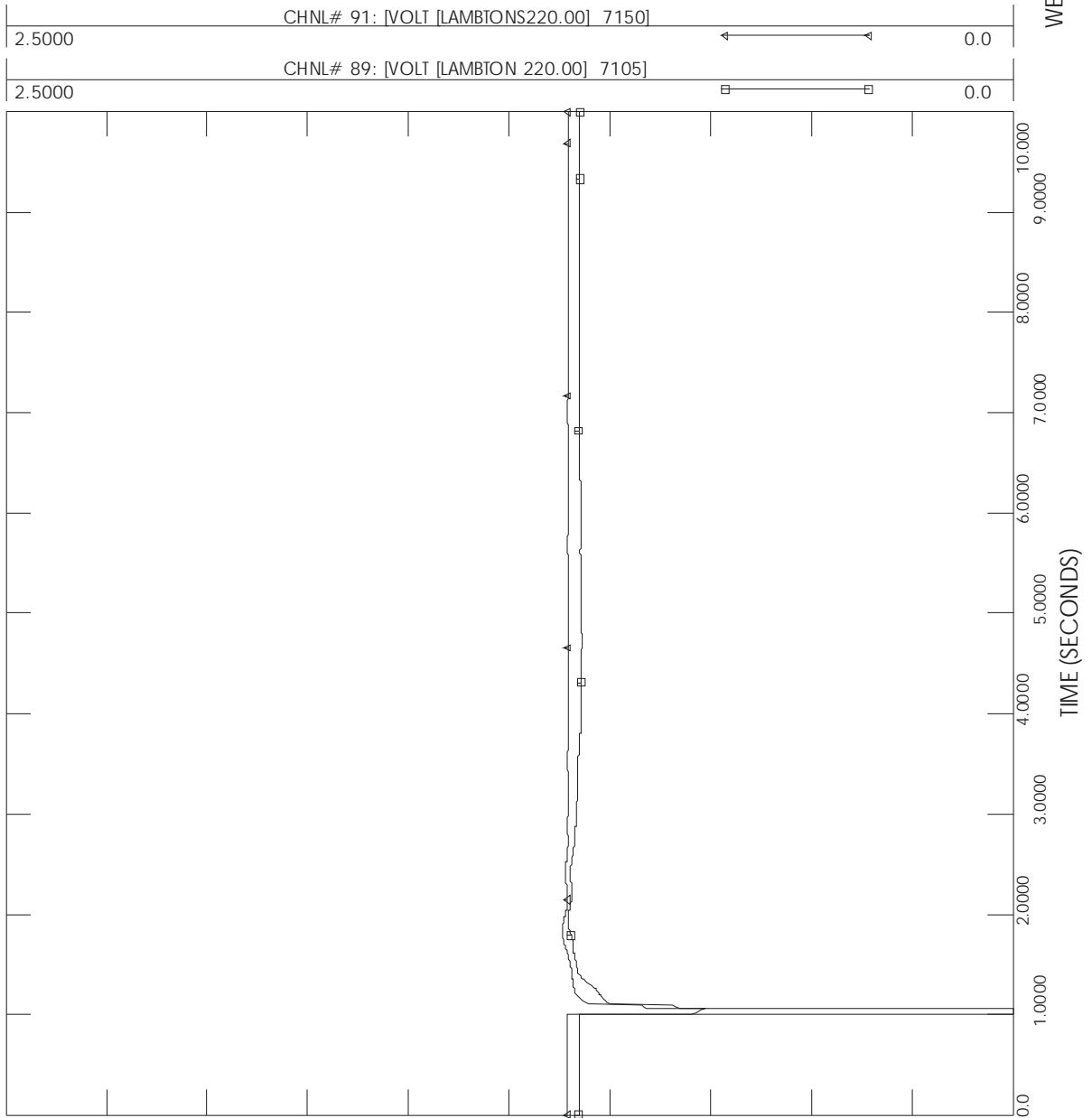

Case 2 – L23N/L25N LL-G fault – Greenfield generators G1, G2, G3 & G4



2010 JULY CASE----- 8_8B6P4D4NOLK2BKOLB2LX16SD2OS
 -530BLIP6904FABC2994FETT1765QFW-604MICH-1138NYNI-250NYSL-14

FILE: case2_L23N_L25N_LLgfault.out

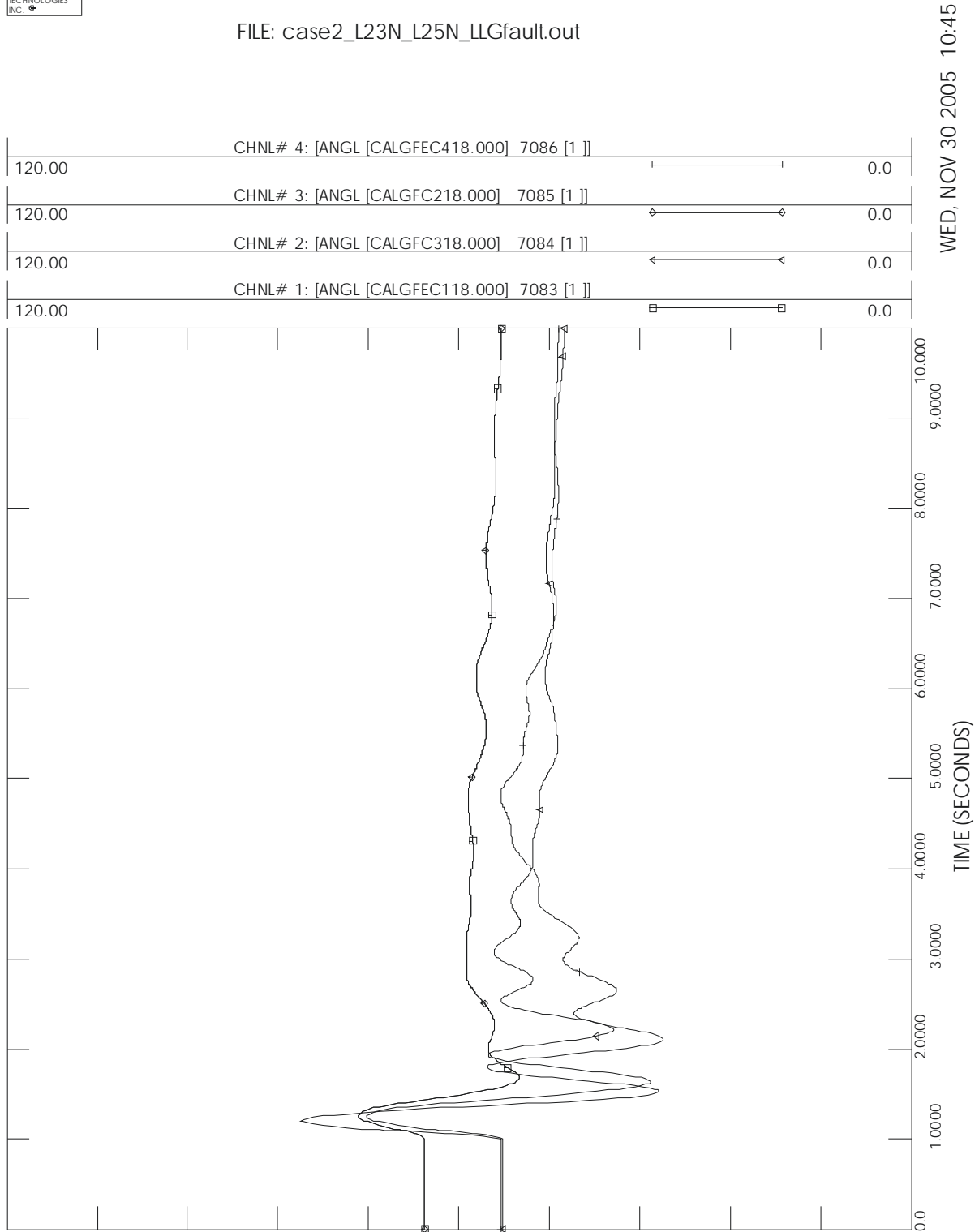

Case 2 – L23N/L25N LL-G fault – St. Clair generators GRTG3, GTG4, STG3 & STG4



2010 JULY CASE----- 8_8B6P4D4NOLK2BK0LB2LX16SD2OS
 -530BLIP6904FABC2994FETT1765QFW-604MICH-1138NYNI-250NYSL-14

FILE: case2_L23N_L25N_LLgfault.out

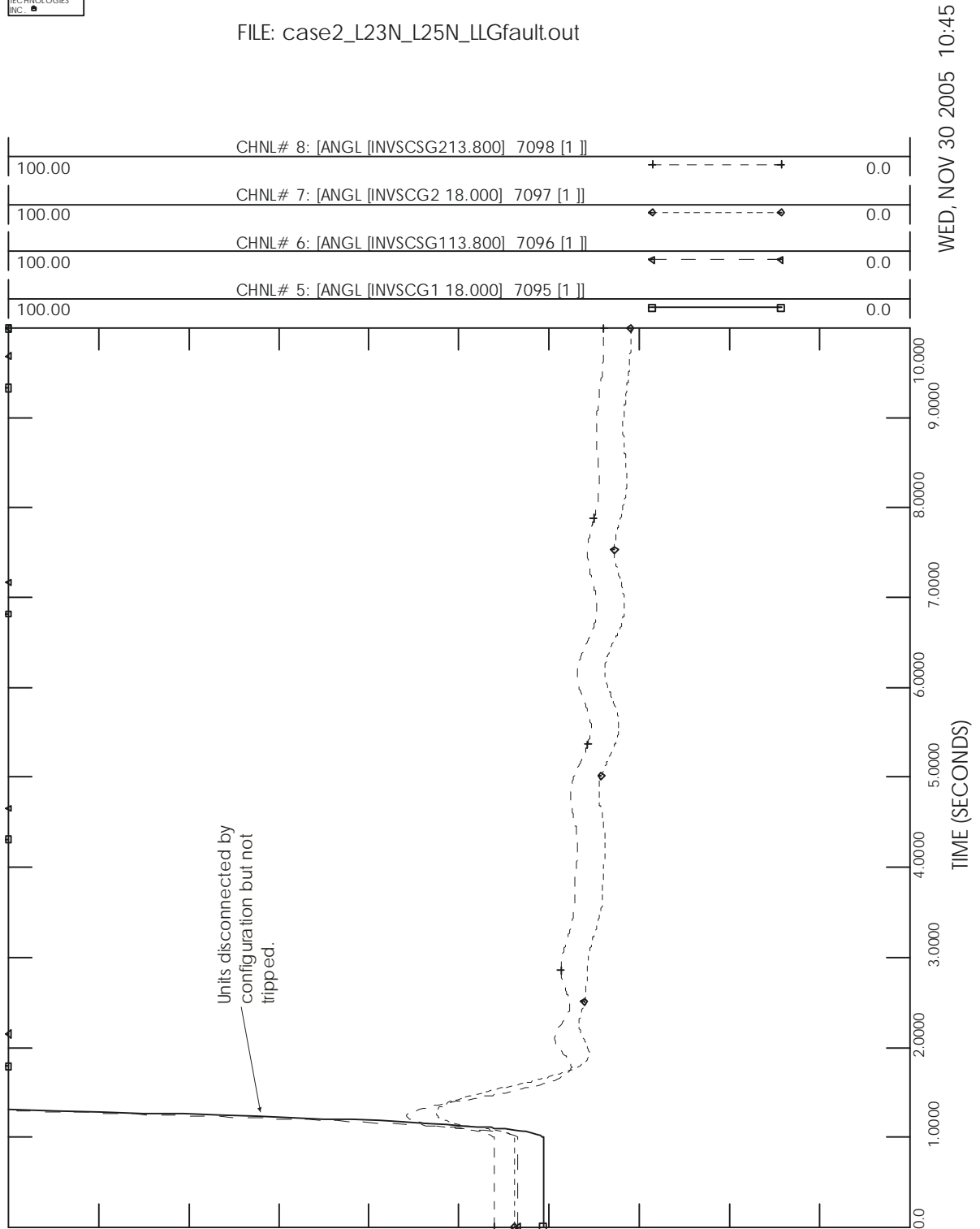

Case 2 – L23N/L25N LL-G fault – Lambton 230 kV Bus Voltage



2010 JULY CASE----- 8_8B6P4D4NOLK2BK0LB2LX16SD2OS
-530BLIP6904FABC2994FETT1765QFW-604MICH-1138NYNI-250NYSL-14

FILE: case2_L23N_L25N_LLgfault.out

WED, NOV 30 2005 10:45

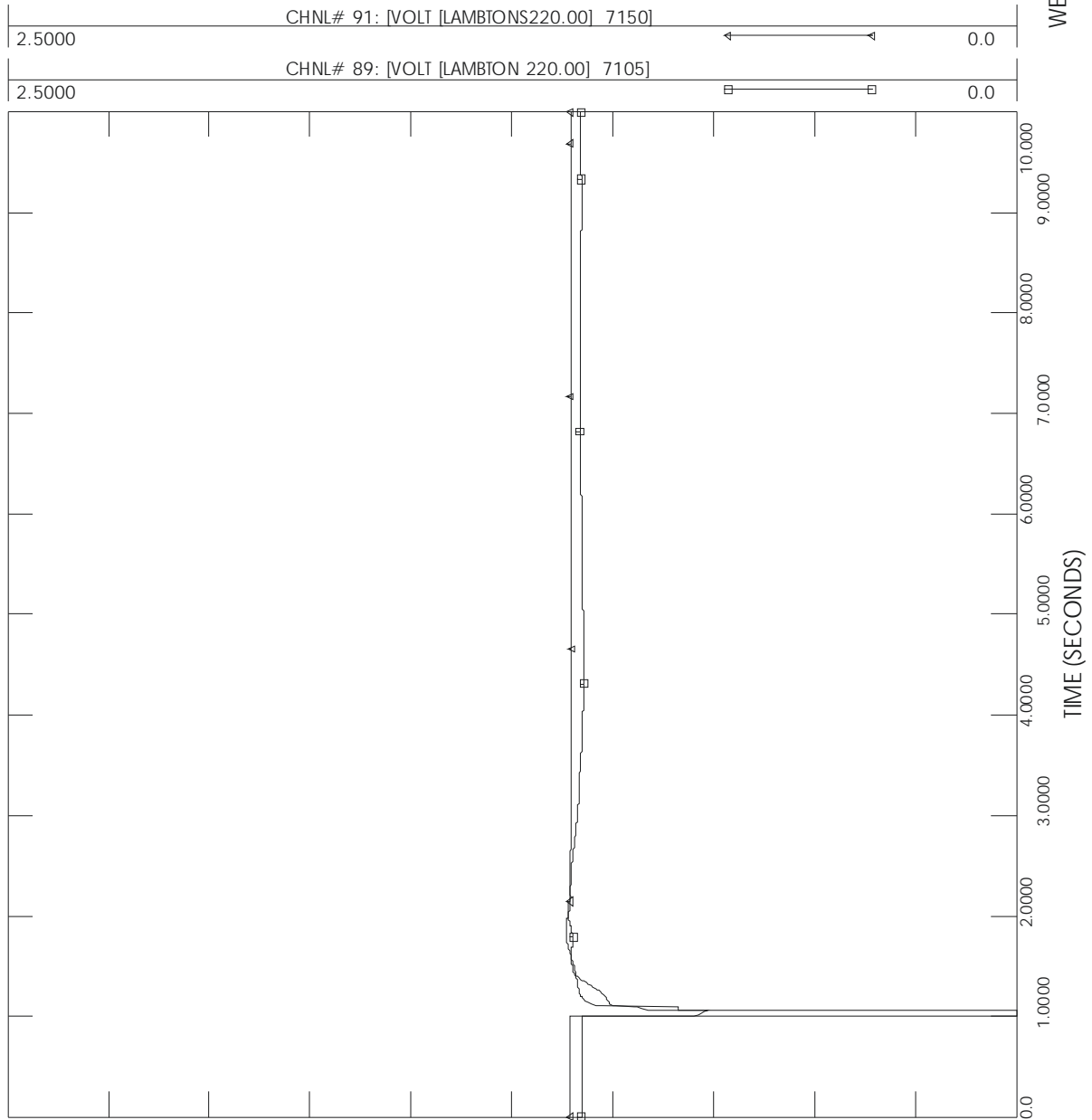

Case 3 – L25N 3-phase fault – Greenfield generators G1, G2, G3 & G4

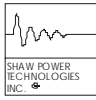

2010 JULY CASE----- 8_8B6P4D4NOLK2BKOLB2LX16SD2OS
 -530BLIP6904FABC2994FETT1765QFW-604MICH-1138NYNI-250NYSL-14

FILE: case3_L25N_3pfault.out

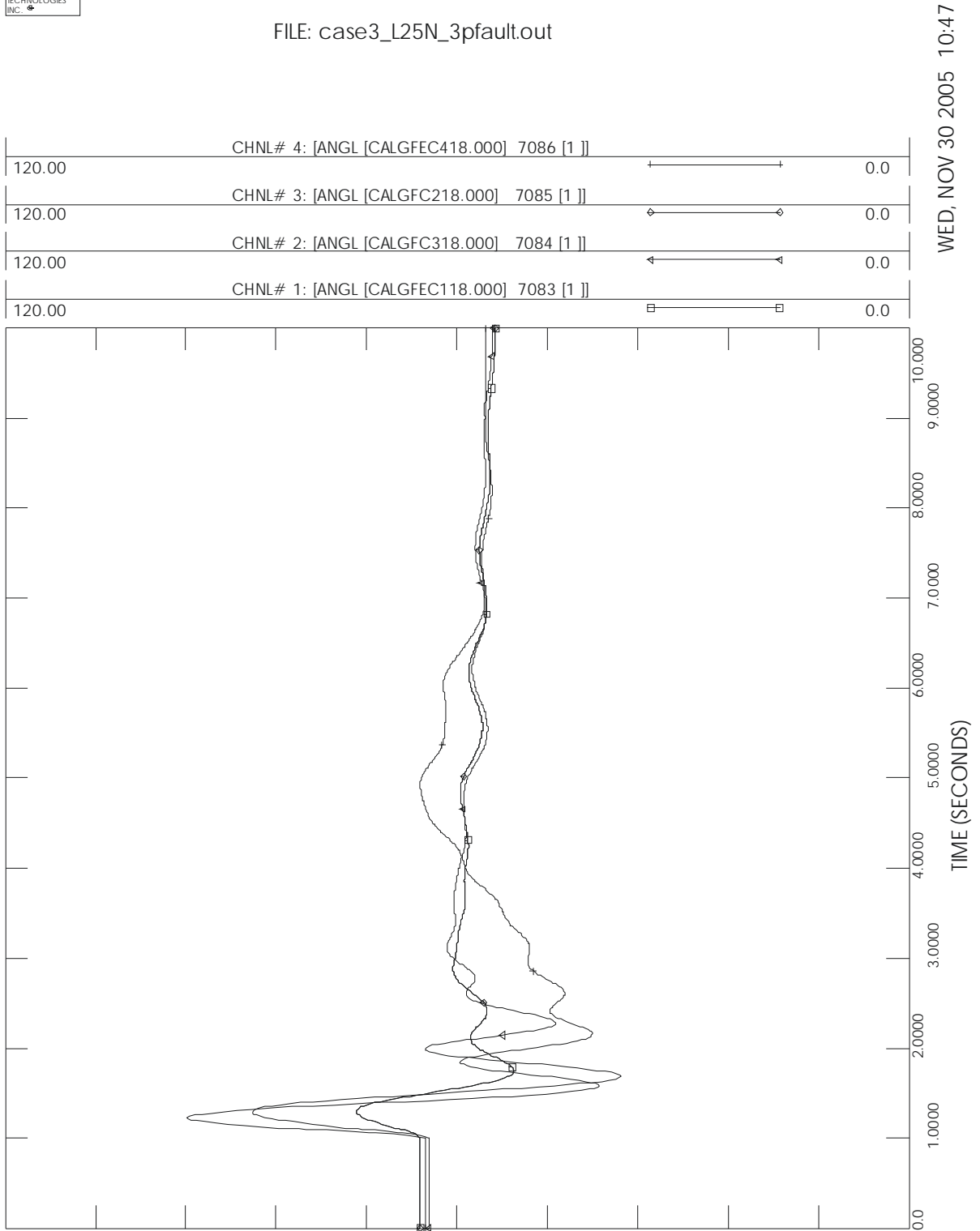

Case 3 – L25N 3-phase fault – St. Clair generators GTG3, GTG4, STG3 & STG4



2010 JULY CASE----- 8_8B6P4D4NOLK2BK0LB2LX16SD2OS
 -530BLIP6904FABC2994FETT1765QFW-604MICH-1138NYNI-250NYSL-14

FILE: case3_L25N_3pfault.out

WED, NOV 30 2005 10:47

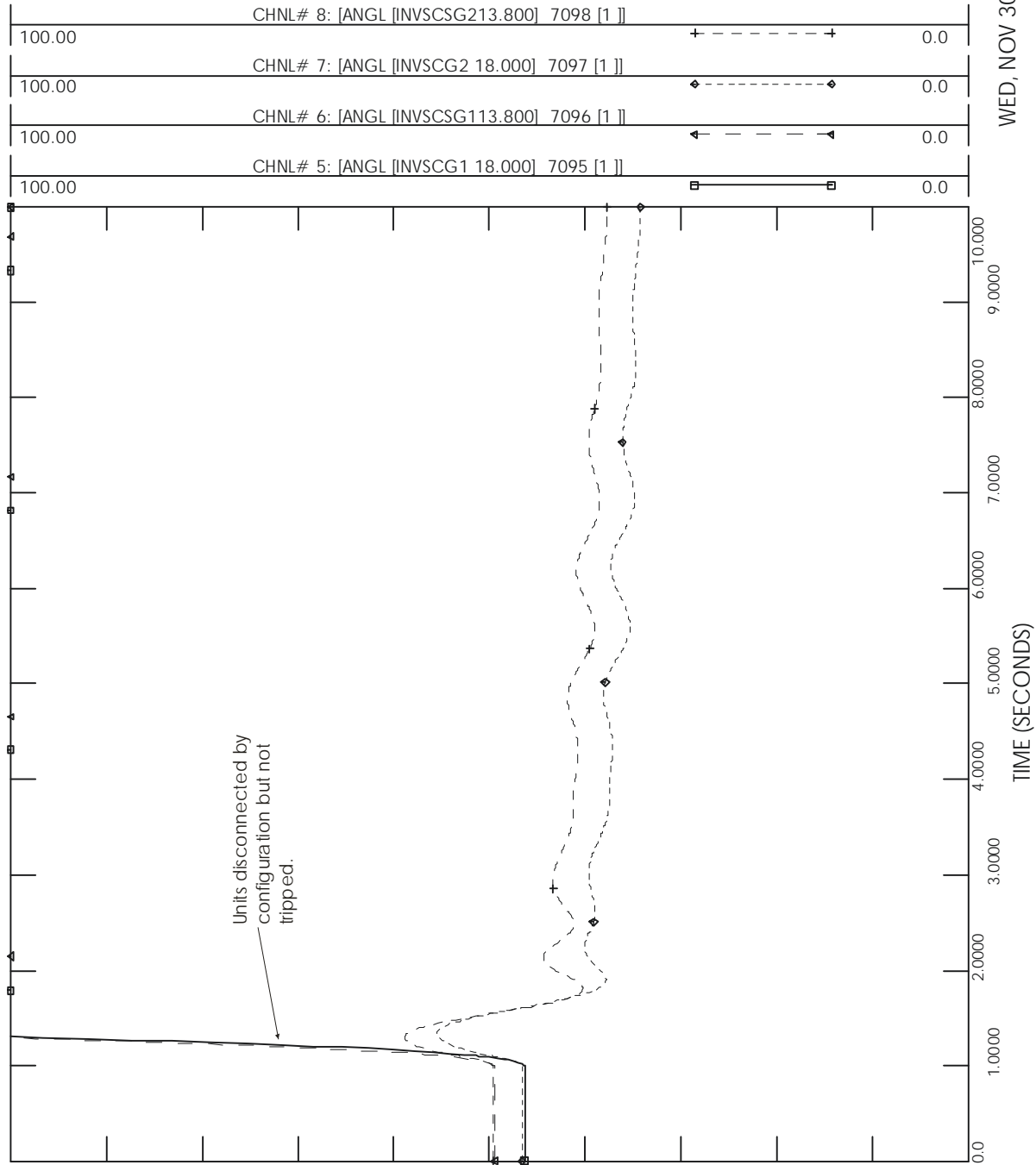

Case 3 – L25N 3-phase fault – Lambton 230 kV Bus Voltage

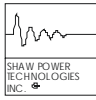

2010 JULY CASE----- 8_8B6P4D4NOLK2BKOLB2LX16SD2OS
-530BLIP6904FABC2994FETT1765QFW-604MICH-1138NYNI-250NYSL-14

FILE: case3_L25N_3pfault.out

WED, NOV 30 2005 10:46

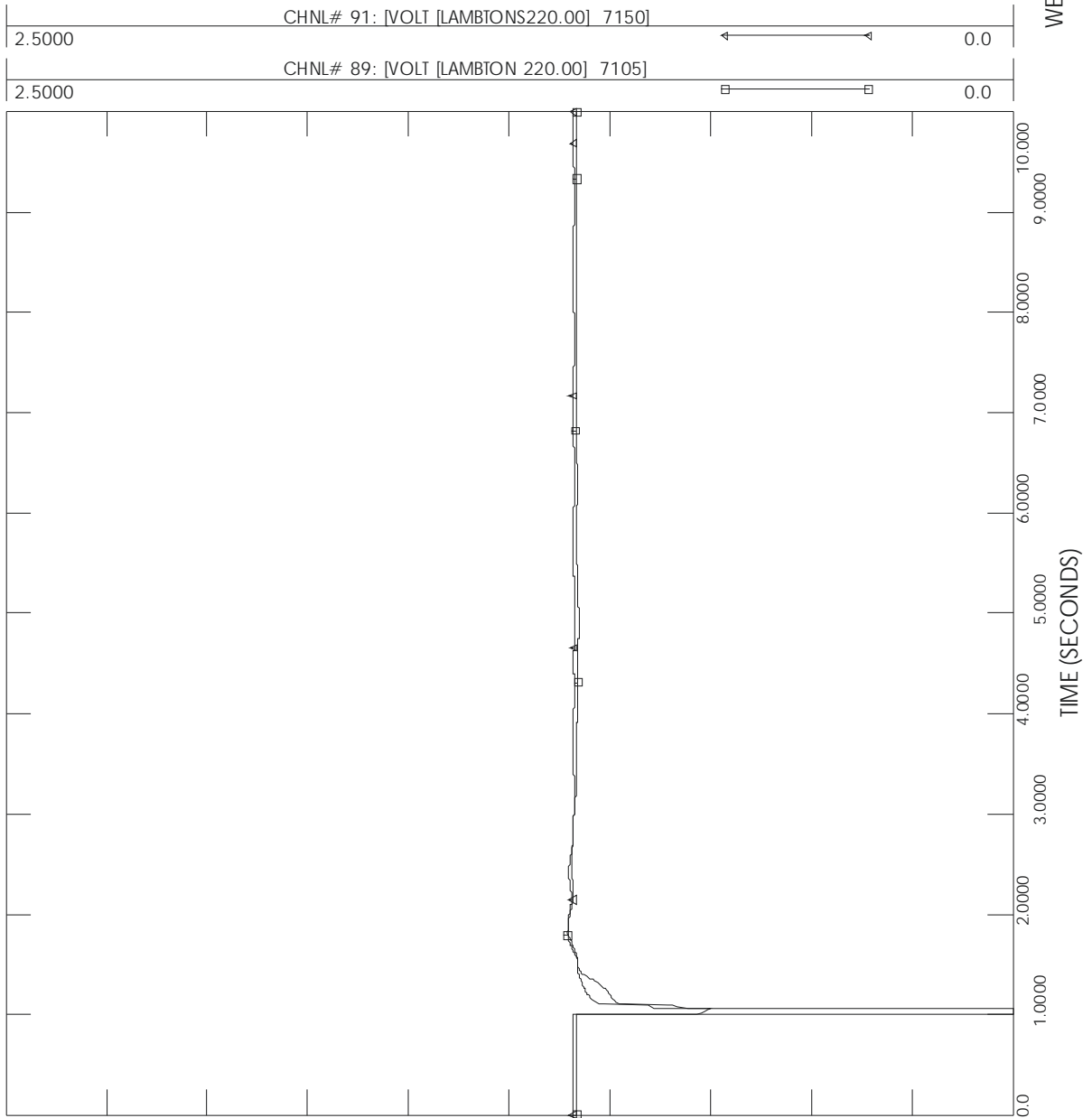

Case 3 – L23N/L25N LL-G fault – Greenfield generators G1, G2, G3 & G4



2010 JULY CASE----- 8_8B6P4D4NOLK2BKOLB2LX16SD2OS
 -530BLIP6904FABC2994FETT1765QFW-604MICH-1138NYNI-250NYSL-14

FILE: case3_L23N_L25N_LLgfault.out

| | | |
|--------|--|-----|
| 120.00 | CHNL# 4: [ANGL [CALGFEC418.000] 7086 [1]] | 0.0 |
| 120.00 | CHNL# 3: [ANGL [CALGFEC218.000] 7085 [1]] | 0.0 |
| 120.00 | CHNL# 2: [ANGL [CALGFEC318.000] 7084 [1]] | 0.0 |
| 120.00 | CHNL# 1: [ANGL [CALGFEC118.000] 7083 [1]] | 0.0 |

WED, NOV 30 2005 10:46

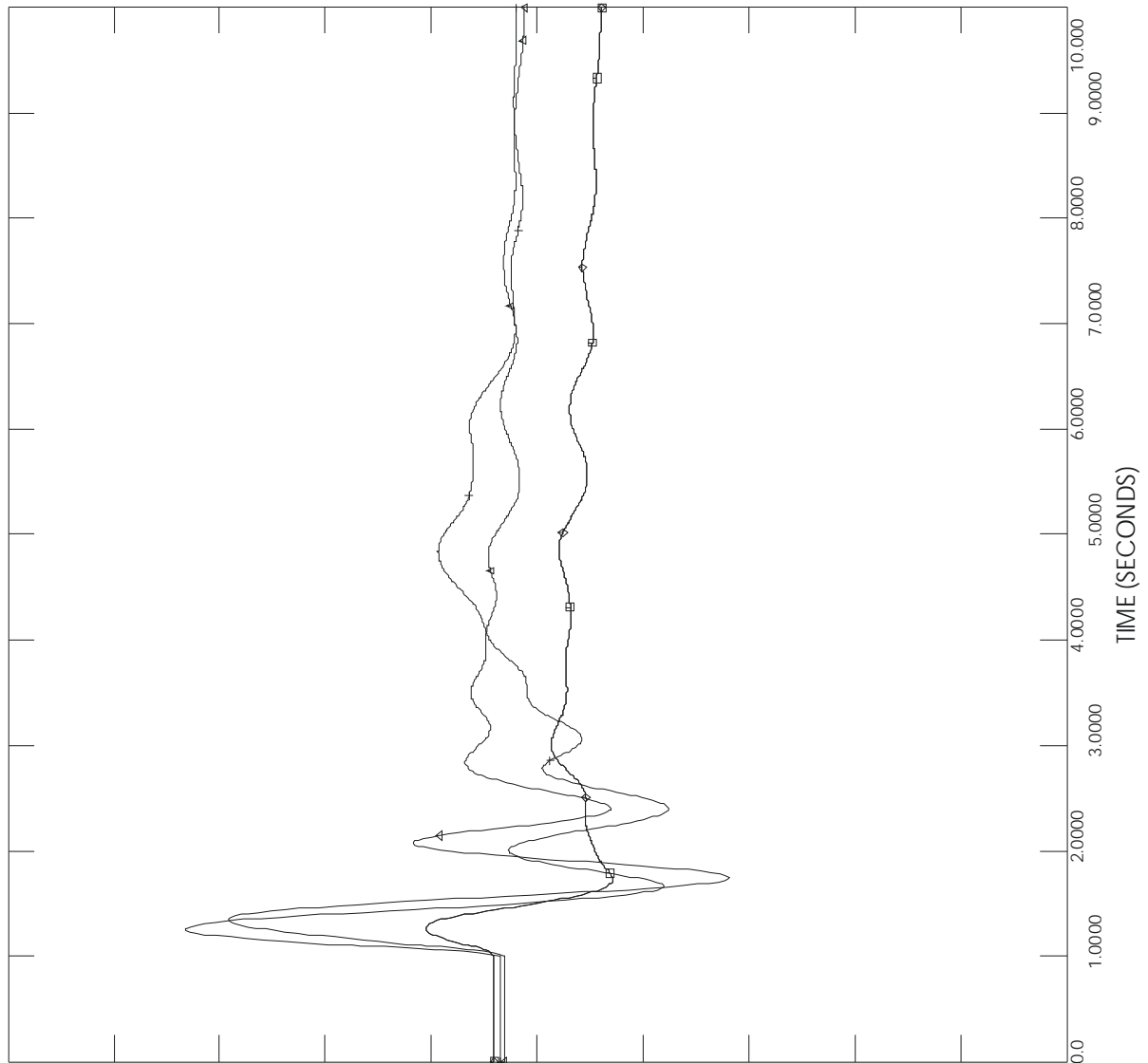

Case 3 – L23N/L25N LL-G fault – St. Clair generators GTG3, GTG4, STG3 & STG4



2010 JULY CASE----- 8_8B6P4D4NOLK2BK0LB2LX16SD2OS
 -530BLIP6904FABC2994FETT1765QFW-604MICH-1138NYNI-250NYSL-14

FILE: case3_L23N_L25N_LLgfault.out

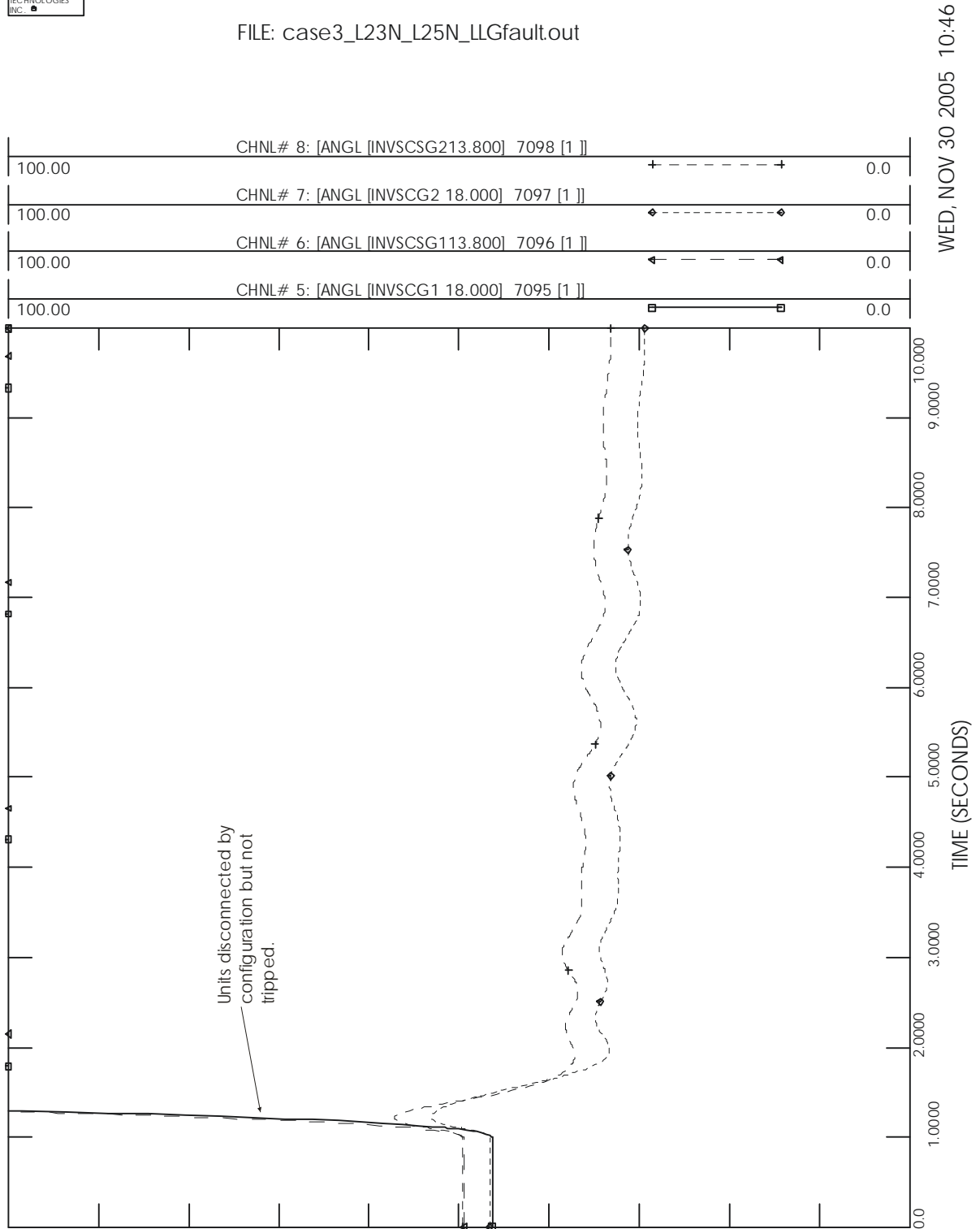

Case 3 – L23N/L25N LL-G fault – Lambton 230 kV Bus Voltage



2010 JULY CASE----- 8_8B6P4D4NOLK2BK0LB2LX16SD2OS
-530BLIP6904FABC2994FETT1765QFW-604MICH-1138NYNI-250NYSL-14

FILE: case3_L23N_L25N_LLgfault.out

WED, NOV 30 2005 10:46

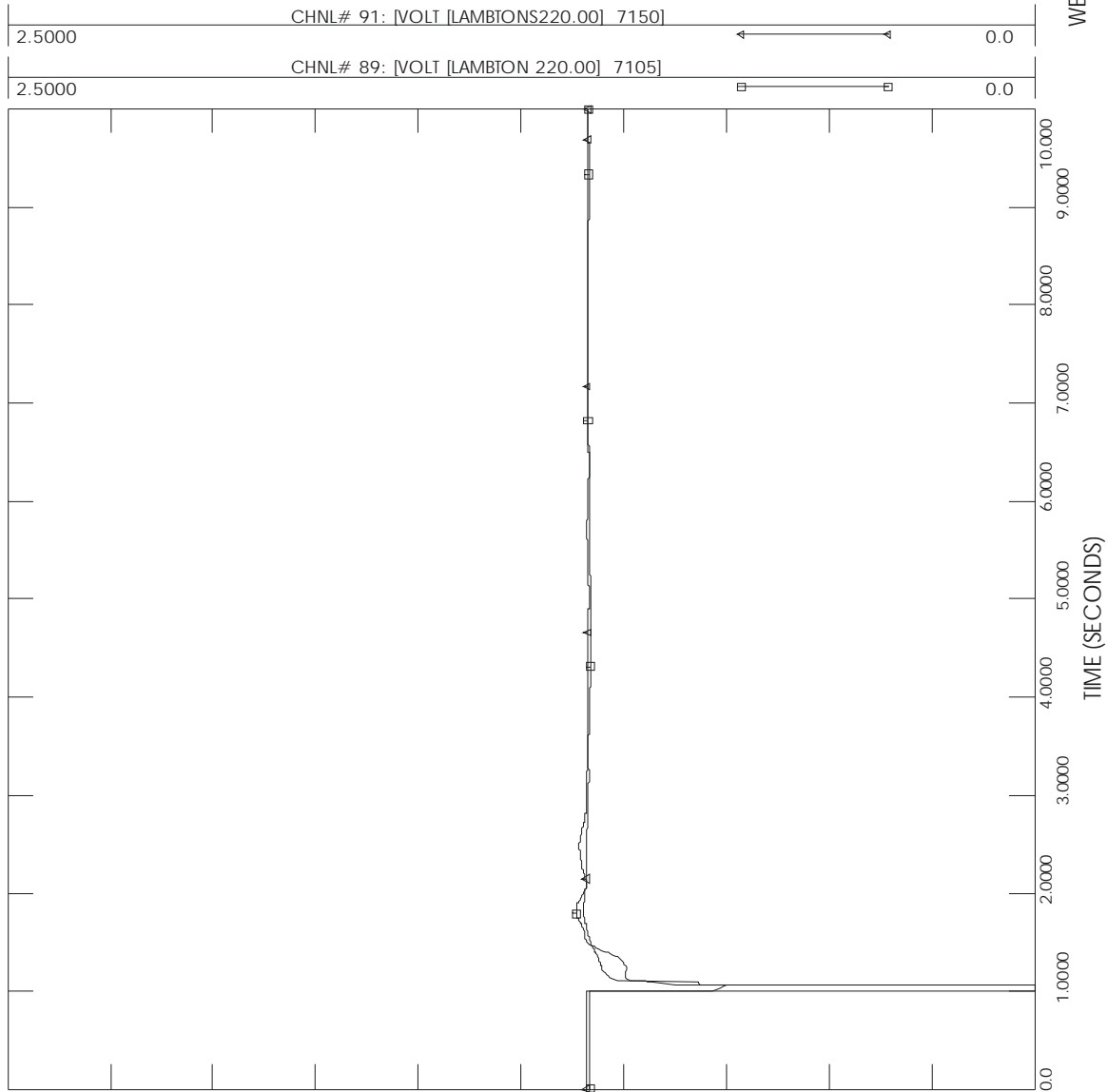

End of Document –