



System Impact Assessment Addendum

CONNECTION ASSESSMENT & APPROVAL PROCESS

Issue 2.0

Project: Greenfield South Power Project

Applicant: Greenfield South Power Corporation

CAA ID 2004-178

Final Report

Transmission Assessments & Performance Department

February 17, 2009

REPORT

- Page intentionally left blank -

Disclaimers

Acknowledgement

The IESO wishes to acknowledge the assistance of Hydro One in completing this assessment.

IESO

This report has been prepared solely for the purpose of assessing whether the connection applicant's proposed connection with the IESO-Controlled Grid would have an adverse impact on the reliability of the integrated power system and whether the IESO should issue a notice of approval or disapproval of the proposed connection under Chapter 4, section 6 of the Market Rules.

Approval of the proposed connection is based on information provided to the IESO by the connection applicant and the transmitter(s) at the time the assessment was carried out. The IESO assumes no responsibility for the accuracy or completeness of such information, including the results of studies carried out by the transmitter(s) at the request of the IESO. Furthermore, the connection approval is subject to further consideration due to changes to this information, or to additional information that may become available after the approval has been granted. Approval of the proposed connection means that there are no significant reliability issues or concerns that would prevent connection of the proposed facility to the IESO-Controlled Grid. However, connection approval does not ensure that a project will meet all connection requirements. In addition, further issues or concerns may be identified by the transmitter(s) during the detailed design phase that may require changes to equipment characteristics and/or configuration to ensure compliance with physical or equipment limitations, or with the Transmission System Code, before connection can be made.

This report has not been prepared for any other purpose and should not be used or relied upon by any person for another purpose. This report has been prepared solely for use by the connection applicant and the IESO in accordance with Chapter 4, section 6 of the Market Rules. The IESO assumes no responsibility to any third party for any use, which it makes of this report. Any liability which the IESO may have to the connection applicant in respect of this report is governed by Chapter 1, section 13 of the Market Rules. In the event that the IESO provides a draft of this report to the connection applicant, you must be aware that the IESO may revise drafts of this report at any time in its sole discretion without notice to you. Although the IESO will use its best efforts to advise you of any such changes, it is the responsibility of the connection applicant to ensure that it is using the most recent version of this report.

HYDRO ONE

Special Notes and Limitations of Study Results

The results reported in this SIA study are based on the information available to Hydro One, at the time of the study, suitable for a SIA of a new generation or load connection proposal.

The short circuit and thermal loading levels have been computed based on the information available at the time of the study. These levels may be higher or lower if the connection information changes as a result of, but not limited to, subsequent design modifications or when more accurate test measurement data is available.

This study does not assess the short circuit or thermal loading impact of the proposed connection on facilities owned by other load and generation (including OPGI) customers.

In this study, short circuit adequacy is assessed only for Hydro One breakers and does not include other Hydro One facilities. The short circuit results are only for the purpose of assessing the capabilities of existing Hydro One breakers and identifying upgrades required to incorporate the proposed connection. These results should not be used in the design and engineering of new facilities for the proposed connection. The necessary data will be provided by Hydro One and discussed with the connection proponent upon request.

The ampacity ratings of Hydro One facilities are established based on assumptions used in Hydro One for power system planning studies. The actual ampacity ratings during operations may be determined in real-time and are based on actual system conditions, including ambient temperature, wind speed and facility loading, and may be higher or lower than those stated in this study.

The additional facilities or upgrades which are required to incorporate the proposed connection have been identified to the extent permitted by a SIA under the current IESO Connection Assessment and Approval process. Additional facility studies may be necessary to confirm constructability and the time required for construction. Further studies at more advanced stages of the project development may identify additional facilities that need to be provided or that require upgrading.

Table of Contents

Disclaimers i

Table of Contents iii

Executive Summary..... 1

Description 1

Findings 1

Notification of Approval for Connection Proposal 2

IESO’s Requirements for Connection 2

1. Project Description..... 5

2. Review of Connection Proposal..... 6

 2.1 Connection Arrangement 6

 2.2 On-line Monitoring 6

 2.3 Protection Systems 6

 2.4 Under-Frequency Tripping..... 6

3. Data Verification 7

 3.1 Generator and Transformer Data..... 7

 3.2 Connection Equipment 7

 3.3 Dynamic Models 8

4. Short Circuit Assessment..... 13

5. System Impact Studies 16

 5.1 Description 16

 5.2 Area Load and Load Growth..... 16

 5.3 Study Assumptions..... 16

 5.4 Thermal Loading Assessment 18

5.5 Voltage Assessment.....	21
5.6 Control Systems Assessment.....	22
5.7 Transient Stability Analysis.....	22
Appendix A: Short Circuit Results.....	A1
Appendix B: Circuit Ratings	B1
Appendix C: Thermal Analysis Results.....	C1
Appendix D: Voltage Analysis Results	D1
Appendix E: Dynamic Control Systems Testing	E1
Appendix F: Transient Stability Analysis	F1
Appendix G: Single Line Diagrams	G1

Executive Summary

Description

The System Impact Assessment (SIA) IESO_REP_0494 released in April 30, 2008 examined the impact on the reliability of the IESO Controlled Grid of the proposed Greenfield South Power Project (Greenfield South). The SIA investigated the connection of the facility to the 230 kV circuit R24C, between Richview TS and Cooksville TS, at 9.4 km from Richview TS.

After the initial SIA report was released, Greenfield South Power Corporation (the Applicant) proposed to have a second connection to the power system for the facility. This new connection will be an alternative connection to the Manby to Cooksville 230 kV circuit K23C. With the new connection, there will be the option of supplying the entire output from Greenfield South to either R24C or K23C, and at no time will the two 230 kV circuits be paralleled at Greenfield South. The length of the tap from the Greenfield South to the existing 230 kV circuit K23C is approximately 800 m, and the location of the proposed tapping point is approximately 2.9 km from Manby East.

Another development changing the conditions assessed in the initial Greenfield South SIA is that Hydro One will relocate the 230 kV circuit R24C from the Richview A1H1bus section to the Richview A2H2 section by the end of 2009, which will very likely occur before Greenfield South connects to the system.

This SIA Addendum documents the IESO's assessment of the new facility to the two connection points by taking into consideration the reconfiguration of the 230 kV circuit R24C.

A new *Customer Impact Assessment* (CIA) has to be performed by the *Transmitter*, Hydro One, to assess the impact the proposed changes have on transmission customers, including neighboring DESN stations and generators. If the CIA or other affected customers identify additional connection requirements that merit significant changes to this SIA Addendum, these requirements would be addressed in further reports.

Findings

This SIA Addendum finds that no network additions or modifications are required to satisfy IESO's reliability standards for the incorporation of the Greenfield South Power Project.

The short circuit levels in the Richview-Manby area will increase with the proposed connection, but they will be within acceptable limits without any additional system reconfiguration. The fault interrupting capability of the proposed high voltage breakers is adequate for the anticipated fault levels.

The connection of the proposed generation plant to either R24C or K23C lines will have a positive impact on the loading of the existing 230 kV transmission lines in the Richview - Manby area. For example, the potential line overloading resulting from single element contingencies as presented in the Appendix C, *Scenario 1.1 - 2009 Peak Load - Greenfields South out of service*, will be eliminated when Greenfield South comes into service.

While part of the double contingency overloading from *Scenario 1.1 2009 Peak Load - Greenfields South out of service* will be mitigated by the new facility, not all of them can be addressed as several double element contingencies remove the positive contribution of Greenfield South to the overloaded lines.

The proposed new generation plant will alleviate loading of the 500 - 230 kV autotransformers in the GTA, especially the autotransformers at Claireville TS. Moreover, it can reduce the flow over the Flow East Towards Toronto (FETT) interface, as it is located on the east side of this interface.

The voltage performance in the GTA and over a wide area in Southwestern Ontario will also improve with the connection of the new generation plant.

In addition to testing of the generator control systems conducted in the initial SIA, the generators' excitation systems were assessed in this Addendum to evaluate the negative field voltage (E_{fd}) response time following a 5% negative reference voltage (V_{ref}) change. While the G1 excitation system was found to meet the Market Rules requirements, the G2 excitation system could not meet these requirements under the open circuit test.

Transient stability studies showed that the power system and the new generation facilities will remain stable with acceptable damping for all examined fault conditions.

No significant differences between connecting the Greenfield South to R24C and connecting it to K23C were identified. However, the ability to connect the generators to either line provides opportunity for the facility to generate electricity and supply the area load when one of the two lines is out of service.

Notification of Approval for Connection Proposal

From the information provided, our review concludes that the proposed connection of the Greenfield South Power Project 374.6 MVA generation station to either 230 kV circuit R24C or K23C will have no material adverse effect on the reliability of the IESO Controlled Grid, subject to meeting the requirements specified below under the heading "IESO's Requirements for Connection". These requirements include the applicable requirements presented in the initial Greenfield South SIA and any additional requirements identified in this Addendum.

It is recommended that a *Notification of Conditional Approval for Connection* be issued for the Greenfield South Power Project subject to the IESO receiving from Applicant written acknowledgement that the requirements described below under the heading "IESO's Requirements for Connection" will be implemented.

If the Greenfield South Power Project either does not meet the performance standards when installed or it is subsequently determined not to meet those performance standards, the IESO connection approval may be withdrawn until the performance standards or their equivalent can be demonstrated.

IESO's Requirements for Connection

The new generation facility has to comply with all applicable NERC, NPCC, Market Rules and Transmission System Code (TSC) requirements. In particular, the IESO has the following requirements.

A. Greenfield South Power Corporation

1. The generators to be installed at the Greenfield South Power Project must satisfy all applicable generator facility requirements in Appendix 4.2, References 1 to 16, of the Market Rules.
2. The facility must be capable of operating at full active power for a limited period of time for grid frequencies as low as 58.8 Hz. The generators must not trip for under-frequency system conditions that are below 60 Hz but above 57.0 Hz and above the curve shown in Figure 1 of this report.
3. The Applicant must provide data for the 13.8 kV breaker 52-G2.

4. The Applicant has to ensure that all new 230 kV equipment is capable of operating continuously in the range between 220 kV and 250 kV, as per Appendix 4.1, Reference 2 of the Market Rules. Transmission equipment must remain in service, and not automatically trip, for voltages up to 5% above the maximum continuous rating, for up to 30 minutes, to allow the system to be re-dispatched to return voltages within their normal range.
5. Protection systems must be designed to meet all the requirements of the TSC and any additional requirements identified by Hydro One. They must be fully duplicated and supplied from separate batteries, and coordinated with the existing schemes. Provided that the TSC requirements are satisfied, the IESO does not have additional requirements.
6. The Applicant is required to have adequate provision in the design of facilities to allow future installation of Special Protection Scheme (SPS) equipment at the Greenfield South facilities. Should a future SPS be installed to improve the transfer capability in the area or to accommodate transmission reinforcement projects, Greenfield South will be required to participate in the SPS system and to install the necessary protection and control facilities to effect the required actions.
7. The Applicant is required to install all the equipment needed to monitor the information as described in Appendix 4.15 and Appendix 4.16 of the Market Rules. The performance monitoring standards will be as specified in Market Rules Appendix 4.19 for major generation facility, and as specified in Appendix 4.20 and Appendix 4.21 for high performance facilities. The IESO requires that the above data be available to the IESO on a continuous basis.
8. The proposed high voltage breakers are adequate for the anticipated fault levels. Their single line to ground (SLG) fault interrupting capability is lower than the 80 kA prescribed by the Transmission System Code (TSC) for the 230 kV system. Should the fault levels exceed breaker capability in future, the Applicant will be responsible for upgrading its breakers to meet the TSC prescribed fault levels.
9. The Applicant has to review the G2 excitation system model and its parameters and ensure that it meets the Market Rules requirements, including those for negative Efd ceiling and the response time for a negative Vref change, before the final approval for connection is granted.
10. The Applicant is required to complete the IESO Market Entry / Facility Registration process in a timely manner before IESO final approval for connection is granted. Manufacturer models and data, including any controls that would be operational, must be provided to the IESO. This information should be submitted at least seven months before first connection to the IESO-Controlled Grid to allow the IESO to perform any additional reliability studies. The control systems are expected to be tuned during commissioning tests.
11. During commissioning, the Applicant must provide evidence to the IESO confirming that the equipment installed meets the Market Rules and additional requirements specified above, and matches or exceeds the performance predicted in the SIA. This evidence shall be either type tests performed in a controlled environment or commissioning tests done on-site. In either case, the testing must be done not only in accordance with widely recognized standards, but also to the satisfaction of the IESO. Until this evidence is provided, the Applicant must accept any restrictions the IESO may impose upon their participation in IESO-Administered Markets or connection to the IESO-Controlled Grid.
12. The operational performance of the equipment must meet or exceed the predicted performance observed in simulations done by the IESO for the SIA. The IESO and the *Transmitter* may be required to take corrective actions in accordance with the Market Rules up to plant disconnection if the performance of the facility would result in adverse impact on the *IESO-Controlled Grid*, e.g. sustained oscillations or excessive voltage decline.
13. Final connection of this project may also be subject to additional requirements specified in the Customer Impact Assessment (CIA) performed by the Transmitter (Hydro One). The CIA will

evaluate the impact of this proposed connection on the customers connected to the transmission system.

B. Hydro One

The IESO has the following requirement:

1. To incorporate Greenfield South, the functionality and fault clearing times of R24C and K23C protection systems must not materially change without prior consent from the IESO.

– End of Section –

1. Project Description

The System Impact Assessment (SIA) IESO_REP_0494 released on April 30, 2008 examined the impact on the reliability of the IESO Controlled Grid of the proposed Greenfield South Power Project (Greenfield South). The SIA investigated the connection of the facility to the 230 kV circuit R24C, between Richview TS and Cooksville TS, at 9.4 km from Richview TS.

After the initial SIA report was released, Greenfield South Power Corporation (the Applicant) proposed to have a second connection to the power system for the facility. This new connection will be an alternative connection to the Manby to Cooksville 230 kV circuit K23C. With the new connection, there will be the option of supplying the entire output from Greenfield South to either R24C or K23C, and at no time will the two 230 kV circuits be paralleled at Greenfield South. The length of the tap from the Greenfield South to the existing 230 kV circuit K23C is approximately 800 m, and the location of the proposed tapping point is approximately 2.9 km from Manby East.

Another development changing the conditions assessed in the initial Greenfield South SIA is that Hydro One will relocate the 230 kV circuit R24C from the Richview A1H1bus section to the Richview A2H2 section by the end of 2009, which will very likely occur before Greenfield South connects to the system.

The proposed system configuration is shown in Appendix G, Figure G-1 of this report.

This SIA Addendum documents the IESO's assessment of the two connection points by taking into consideration the reconfiguration of the 230 kV circuit R24C.

– End of Section –

2. Review of Connection Proposal

2.1 Connection Arrangement

It is recognized that part of the generator data sent by the Applicant is based on preliminary assumptions, and the results are derived from these data. If the final generator and generator control data are materially different from those used in this study, a new assessment may be required to complete the analysis.

The Applicant proposed to have the entire plant connecting to either 230 kV line R24C through the 89-L1 disconnect switch 89-L1, or to the 230 kV line K23C through the disconnect switch 89-L2. An interlock will prevent both disconnects to be closed at the same time. In addition, one 230 kV breaker will be used to connect the plant to the 230 kV transmission system.

Internally, the combustion turbine generator (G1) and its MT1 step-up transformer would connect to the 230 kV bus through the 230 kV 52-T1 breaker. The steam turbine generator (G2) and its step-up transformer MT-2 would connect to the 230 kV bus through a high-voltage disconnect switch. A 13.8 kV unit breaker would be used for G2 unit synchronization. The proposed configuration is shown in Appendix G, Figure G-1.

2.2 On-line Monitoring

The on-line monitoring requirements specified in the Greenfield South SIA report are applicable.

2.3 Protection Systems

The protection systems requirements specified in the Greenfield South SIA report are applicable.

2.4 Under-Frequency Tripping

The under-frequency tripping requirements specified in the Greenfield South SIA report are applicable.

– End of Section –

3. Data Verification

Other than the second connection to the 230 kV K23C, which includes the addition of the 230 kV disconnect switch 89-L2, there are no changes to the data provided for the Greenfield South SIA. All equipment parameters are relisted in the Addendum.

3.1 Generator and Transformer Data

The generator and transformer requirements specified in the Greenfield South SIA report are applicable.

Table 1 – Generator Data

<i>Station</i>	<i>Unit</i>	<i>Type</i>	<i>MVA</i>	<i>Rated PF</i>	<i>Maximum MW</i>	<i>kV</i>	<i>Xd''</i>
Greenfield South	G1	CTG	217.0	0.90	213	16.5	0.172
	G2	STG	157.6	0.85	122	13.8	0.21

Table 2 – Generators – Reactive Power at Rated MW

<i>Station</i>	<i>Unit</i>	<i>Rated MW</i>	<i>Q minimum required at Rated MW (0.95 pf)</i>	<i>Q maximum required at Rated MW (0.9 pf)</i>	<i>Q minimum capability curve</i>	<i>Q maximum capability curve</i>
Greenfield South	G1	195.30	-64.2	94.59	-78.0	94.6
	G2	122	-40.1	59.09	-50.4	89.8

Table 3 - Transformers

<i>Station</i>	<i>Transformer</i>	<i>MVA</i>	<i>Winding Connection</i>	<i>kV</i>	<i>X %</i>	<i>Zo %</i>	<i>MVA base</i>	<i>Taps</i>	<i>X% on Gen MVA</i>
Greenfield South	MT1	250	Yo - d	242-16.5	9	8.5	150	+/-2x2.5%	13.01
	MT2	200	Yo - d	242-13.8	10	8.5	120	+/-2x2.5%	13.11

3.2 Connection Equipment (buses, circuit breakers, disconnects)

The connection equipment requirements specified in the Greenfield South SIA report are applicable.

Table 4 - Breakers

Station	Breaker	Rated kV	Interrupting Time	Rated Continuous (A)	Interrupting Media	Interrupting Capability (kA)	
						Symm.	Asymm.
Greenfield South	52-L1	242	50 ms	1200 A	SF6	65	?
	52-T1	242	50 ms	1200 A	SF6	65	?
	52-G2	13.8	?	?	?	?	?

Table 5 – Disconnect Switches

Station	Switch	Rated kV	Rated Continuous A
Greenfield South	89-L1, 89-L2	242	1200 A
	89-T1, 89-T2	242	1200 A

3.3 Dynamic Models

The generator dynamic control systems requirements specified in the Greenfield South SIA report are applicable.

(a) Generators

Table 6 – Generator Dynamic Data - Model GENROU

CONs	CTG - G1	STG- G2
T'_{do}	9.921	7.11
T''_{do}	0.048	0.037
T'_{qo}	1.10	2.29
T''_{qo}	0.085	0.14
H	4	6.72
D	0	0
X_d	1.79	2.20
X_q	1.75	2.09
X'_d	0.229	0.30
X'_q	0.41	0.50
$X''_d = X''_q$	0.172	0.21
X_l	0.14	0.15
S(1.0)	0.08	0.244
S(1.2)	0.35	0.3396
M_{base}	217	157.6

(b) Automatic Excitation Systems

Table 7 – G1 – Excitation System - Model ST1A

	CONs	CTG - G1
Terminal voltage transducer time const.	T_R	0.012
AVR maximum output	V_{IMAX}	999
AVR minimum output	V_{IMIN}	-999
AVR lead time constant	T_C	0
AVR lag time constant	T_B	0
AVR lead time constant	T_{C1}	0
AVR lag time constant	T_{B1}	0
AVR gain	K_A	210
AVR time constant	T_A	0
Regulator maximum output	V_{AMAX}	999
Regulator minimum output	V_{AMIN}	-999
Exciter maximum output	V_{RMAX}	7.5
Exciter minimum output	V_{RMIN}	-6.2
Rectifier regulation	K_C	0.1
Exciter feedback gain	K_F	0
Exciter feedback time constant	T_F	1
Field current limiter gain	K_{LR}	0
Field current limiter gain setting	I_{LR}	0
Alternate UEL input	UEL	2
Alternate Stabilizer input	VOS	1

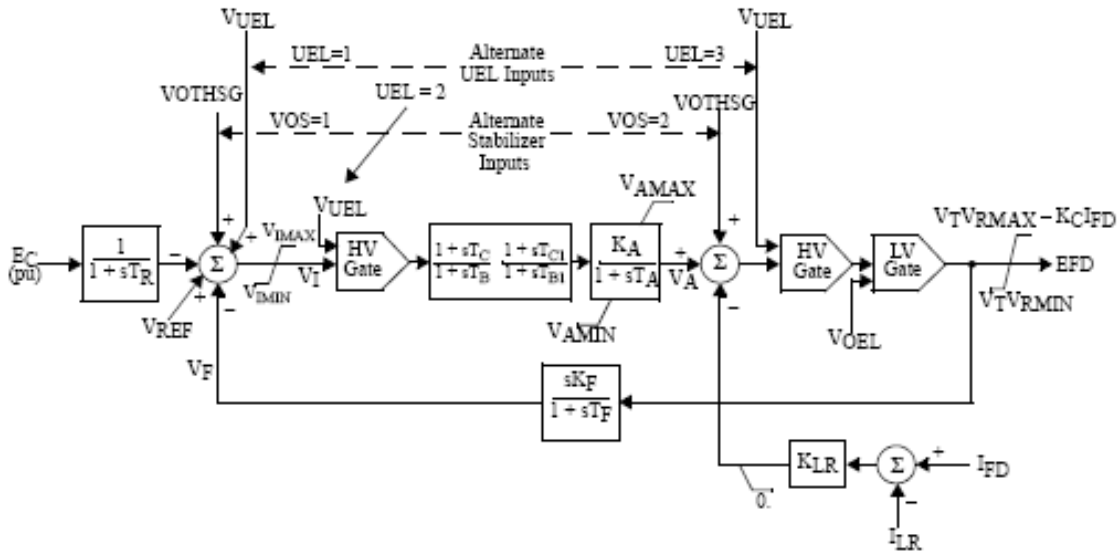
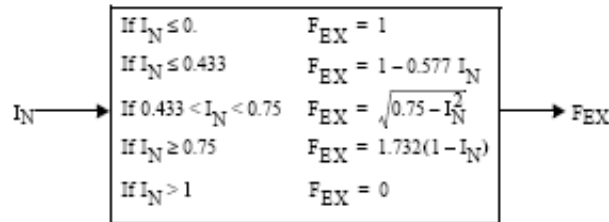
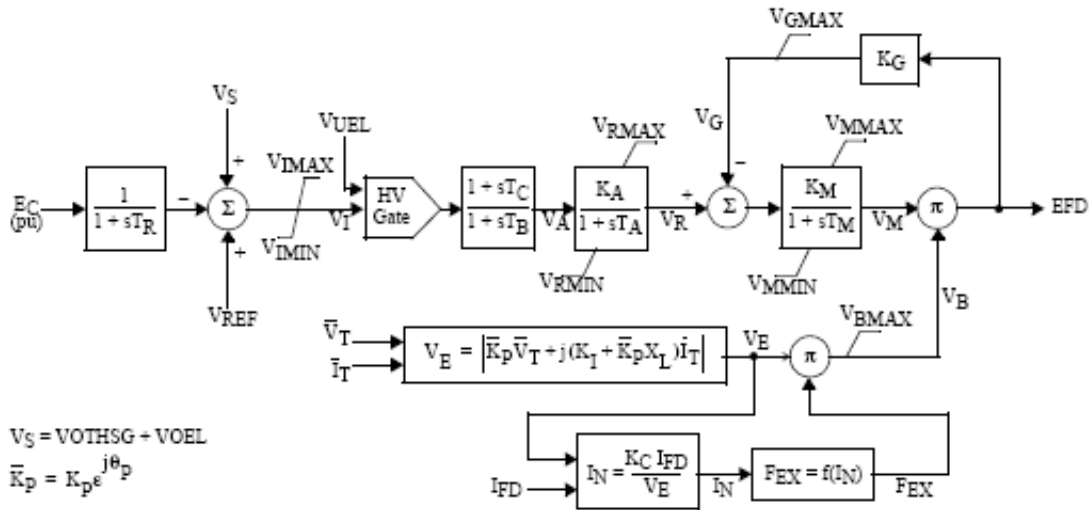

Table 8 – G2 – Excitation System Model ST3A

	<i>CONs</i>	<i>STG - G2</i>
Terminal voltage transducer time const.	T_R	0
AVR maximum output	V_{IMAX}	1
AVR minimum output	V_{IMIN}	-1
Regulator forward gain constant	K_M	2
AVR lead time constant	T_C	1
AVR lag time constant	T_B	10
AVR gain	K_A	600
AVR time constant	T_A	0
Exciter maximum output	V_{RMAX}	10
Exciter minimum output	V_{RMIN}	-10
Regulator feedback gain constant	K_G	1
Exciter gain constant	K_P	5.85
Exciter gain coefficient	K_I	0
Exciter voltage limit	V_{BMAX}	7.25
Rectifier loading factor	K_C	0.5
Reactance	X_L	0
Regulator feedback limit	V_{GMAX}	6
Phase angle	θ_P	0
Regulator forward time constant	T_M	0.5
Regulator maximum output	V_{MMAX}	10
Regulator minimum output	V_{MMIN}	-10



(c) Power System Stabilizer (PSS)

Since the proposed PSS1A model was not included in the PTI software used for this assessment, a modified PTI IEEEEST model was used to reflect the PSS1A behavior model provided by the Applicant.

Table 9 – G1 and G2 – Power System Stabilizer: Model PSS1A and IEEEEST representation

	<i>PSS1A model</i>	<i>IEEEEST model</i>	<i>CTG – G1</i>	<i>STG - G2</i>
		ICONS		
Stabilizer input code:		ICS1	1	1
		CONs		
Frequency filter constant	A1	A1	0	0
Frequency filter constant	A2	A2	0	0
Frequency filter constant	T6	A3	0.01	0.05
Frequency filter constant		A4	0	0
Frequency filter constant		A5	0	0
Frequency filter constant		A6	0	0
Phase lead time constant	T ₁	T ₁	0.5	0.15
Phase lag time constant	T ₂	T ₂	0.2	0.05
Phase lead time constant	T ₃	T ₃	0.5	0.15
Phase lag time constant	T ₄	T ₄	0.2	0.05
Phase lead time constant	T ₅	T ₅	5	2
Phase lag time constant	T ₅	T ₆	5	2
Stabilizer gain	K _S	K _S	1	0.8
Output limits	V _{STMAX}	L _{STMAX}	0.1	0.05
Output limits	V _{STMIN}	L _{STMIN}	-0.05	-0.05
Output limits		V _{CU}	0	0
Output limits		V _{CL}	0	0

PSS1A model, provided by the Applicant:

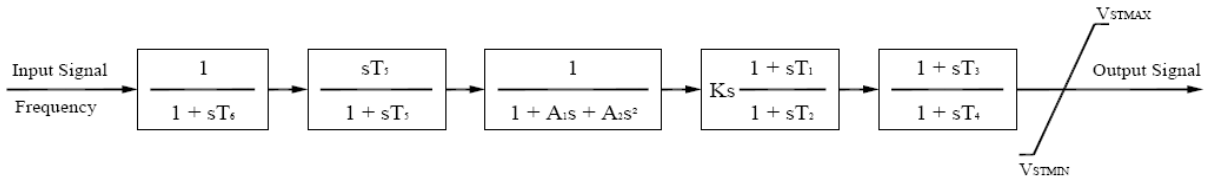

IEEEEST model, used in simulations to represent the functionality of the PSS:

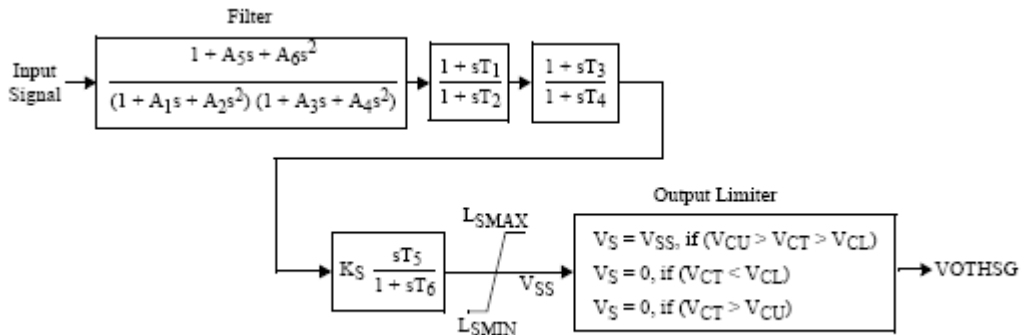

d) Speed Governor Systems

Table 10 – G1 – Gas Turbine Governor – Model WESGOV

CONs	G1
Δt sample for controls, ΔTC (sec)	0.1
Δt sample for PE, ΔTP (sec)	1.0
Droop	0.05
K_p	2
$T_1(>0)$ (sec)	4
T_1 (sec)	0.5
T_2 (sec)	0.59
A_{LIM}	0.1
T_{pe} (sec)	0.25

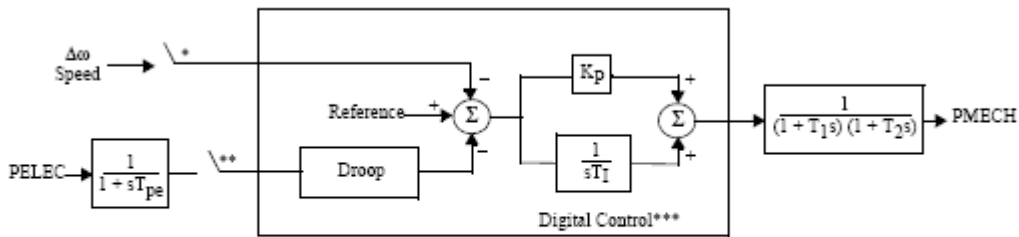

*Sample hold with sample period defined by ΔTC .
 **Sample hold with sample period defined by ΔTP .
 ***Maximum change is limited to A_{LIM} between sampling times.

Table 11 – G2 – Steam turbine governor – model TGOV1

	CONs	G2
Speed Droop (pu)	R	0.05
Time constant	$T_1 (>0)$	0.02
Max. fuel valve opening (pu)	V_{MAX}	1
Min. fuel valve opening (pu)	V_{MIN}	0
Time constant	T_2	0
Time constant	$T_3 (>0)$	0.1
Turbine Dumping Factor	D_t	0

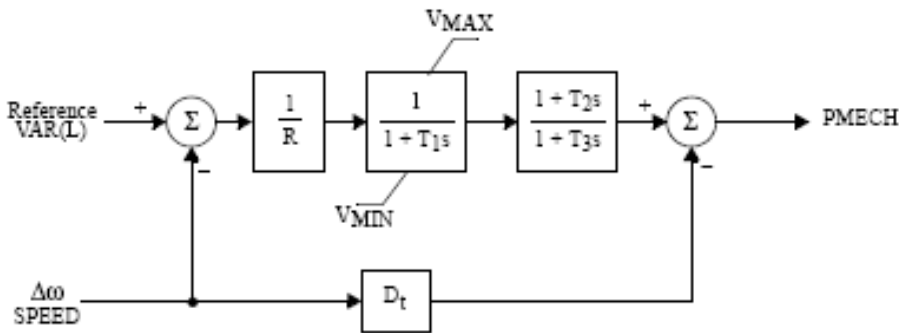

– End of Section –

4. Short Circuit Assessment

The SIA Addendum evaluates the adequacy of the high voltage circuit breakers to interrupt the maximum anticipated short circuit currents under the predicted system configuration when Greenfield South connects to the system. The analysis uses the shortcircuit levels provided by Hydro One.

In addition to this short circuit assessment, Hydro One conducts the Connection Impact Assessment (CIA) short circuit assessment to verify that the fault interrupting devices at the connection point of its customers and on the low voltage side of its transformer stations are adequate to interrupt the increased short circuit levels attributable to the connection of a new facility.

The following base conditions were assumed for the short circuit studies:

Generation in service

1. 8 Bruce units
2. 4 Darlington units
3. 6 Pickering units
4. 8 Nanticoke units
5. 4 Lambton units
6. 4 Lennox units
7. All existing hydraulic generation
8. GTAA (44 kV buses at Bramalea TS and Woodbridge TS – 117 MW)
9. TransAlta Douglas (44 kV buses at Bramalea TS – 110 MW)
10. West Windsor Power (J2N – 129 MW)
11. TransAlta Sarnia (N6S/N7S – 580 MW)
12. Brighton Beach (J20B/J1B – 680 MW)
13. Imperial Oil (N6S/N7S – 112 MVA)
14. All constructed wind farms including Erie Shores WGS (W8T – 99 MW), Kingsbridge WGS (Goderich TS – 39.6 MW), Amaranth WGS – Amaranth I (B4V – 67.5 MW)

New Generation:

15. Future committed generation: Greenfield Energy Centre (new L37G/L38G – 1,147 MW), St. Clair Energy Centre (V41N/V43N – 638 MW), Thorold (Q10P – 236 MW), East Windsor Cogen (E8F/E9F – 84 MW) plus existing Ford generation, Beck 1 G7 conversion to 60 Hz (68.5 MVA)
16. Sithe Goreway
17. Portlands Energy Centre
18. Halton Hills
19. Future committed wind generation: Wolfe Island (198MW); Leader A and B (99 + 101 MW), Kingsbridge II (159 MW), Ripley (76 MW), Kruger Port Alma (101 MW), Melancton II (132 MW)

Transmission system configuration

Existing system with the future upgrades, including:

1. Claireville TS 230 kV re-configured as per SIA CAA ID 2006-220 and operated *split*
2. V75R terminated at Richview
3. **R24C re-terminated at Richview A2H2 bus**
4. Hurontario SS in service with R19T+V72R split from R21T+V73R: 230 kV circuits V72R and V73R extended from Cardiff TS and connected to Hurontario SS
5. Essa-Stayner 115 kV circuit replaced by 2 x 230 kV circuits; Stayner TS converted to 230 kV; 230/115 kV auto installed to supply Meaford TS
6. 500kV Series Capacitors providing 50% compensation for the Hanmer-to-Essa circuits
7. 500kV Series Capacitors providing 30% compensation for the Bruce-to-Longwood circuits & the Longwood-to-Nanticoke circuit
8. Bruce x Orangeville 230 kV circuits up-rated
9. 2 new circuits Allanburg x Middleport (Q35M and Q26M) installed
10. Additional two 245 MVar capacitors installed at Orangeville TS and Detweiler TS, one per station
11. Additional LV shunt capacitors installed at Meadowvale TS and Halton TS
12. New 230/115 kV auto at Cambridge-Preston TS
13. 1250 MW HVDC line ON-HQ in service
14. new 500 kV double circuit from Bruce to Milton in service

15. Richview TS 230 kV operated *split*
16. Claireville TS 230 kV operated *split*
17. Leaside TS 230 kV operated *split*
18. Leaside TS 115 kV operated *split*
19. Middleport TS 230 kV bus operated *split*
20. Hearn SS operated *split* – as required in the Portlands SIA
21. Cooksville TS 230 kV bus *closed*
22. All capacitors in service
23. All tie-lines in service and phase shifters on neutral taps
24. Maximum voltages on the buses.

For the asymmetrical shortcircuit currents, a 25 ms contact parting time was assumed for breakers at voltage levels of 115 kV and below, and a 33 ms contact parting time was assumed for breakers at voltage levels of 230 kV and above.

The two scenarios evaluated in this Addendum are presented in Table 12 below.

Table 12 – Short circuit Scenarios

<i>Case</i>	<i>Scenario</i>
A. Greenfield S connected to R24C	Greenfield S I/S, Cooksville solid
B. Greenfield S connected to K23C	Greenfield S I/S, Cooksville solid

The detailed results for the study case are tabulated in the Appendix A of this report. The following conclusions are to be mentioned.

- a. With the addition of Greenfield South to the system, the shortcircuit levels at the transmission stations in the studied area will remain below the breakers' interrupting capability, without any additional system reconfiguration.

- b. There will be not material difference in shortcircuit levels between the two proposed connection points. This is expected, as the two circuits R24C and K23C will connect to the same A2H2 switchyard section at Richview TS.
- c. There are three stations in the studied area where the shortcircuit levels are approaching the breakers interrupting capability: Manby West 118 kV yard, Manby East 118 kV yard and Richview 230 kV. However, the shortcircuit levels remain below the interrupting capability of the existing equipment. The smallest cushion is at Manby West TS 118 kV switchyard, with a 1.32 kA asymmetrical line-to-ground shortcircuit margin.
- d. As previously identified in other SIAs, the asymmetrical line-to-ground shortcircuit level at Leaside TS is critical. This is a recognized problem the IESO and Hydro One are currently working to address. Greenfield South is located relatively remote from this station, and its impact on the Leaside fault levels is not material. About 40 A fault contribution was observed in the previous SIA from Greenfield South at Leaside TS 118 kV buses.
- e. The latest shortcircuit calculation revealed that, with a 25 ms contact parting time, the Cherrywood 230 kV asymmetrical line-to-ground shortcircuit level becomes critical, with the Cherrywood DK3 section having only about 230 A margin. The Greenfield South fault contribution to this bus was calculated to be in a 200 A range in the Greenfield South SIA.

- End of Section -

5. System Impact Studies

5.1 Description

The technical studies conducted in this Addendum focused on identifying the impact of the new generation station on the reliability of the IESO Controlled Grid, by taking into account the two connection points and the reconfiguration of the 230 kV R24C circuit.

It includes thermal loading assessment of 230 kV transmission lines in the Manby-Cooksville area, system voltage performance assessment in the GTA, and transient stability assessment of the proposed and major existing generation units.

The methodology and assumptions specified in the Greenfield South SIA report are applicable.

5.2 Area Loads and Load Growth

Details about the area load and the load growth were presented in the Greenfield South SIA and are applicable to this Addendum.

The total load in the Manby-Cooksville area peaked at 1,529 MW in August 1, 2006, when the Ontario absolute peak demand of 27,005 MW was recorded.

The load growth forecast for the stations in the studied area was assumed to be as per the joint study produced by Hydro One and Toronto Hydro in 2006. This load forecast was compared with the actual loading that occurred on August 1, 2006 when the highest Ontario system peak was set, and it was found that the forecast is reflecting a fair load distribution.

5.3 Study Assumptions

Based on the information provided by the Applicant, the new generation plant has been added to the IESO load flow model. The parameters used for simulation are listed in section 3. *Data Verification* of this report.

The connection point to the 230 kV line R24C is at 9.4 km from Richview terminal, as per initial SIA. In addition, the second connection point was added to the 230 kV line K23C at 2.9 km from Manby East TS, and the 230 kV circuit R24C has been relocated from Richview A1H1 switchyard to Richview A2H2 switchyard.

Thermal ratings

Details about the thermal ratings presented in the Greenfield South SIA are applicable.

The thermal ratings used for the existing transmission elements in the area were confirmed or provided by Hydro One, which is the transmitter and equipment owner, and are presented in Appendix B of this report.

Load Modeling

Details about the load modeling presented in the Greenfield South SIA are applicable.

Load was modeled as a *constant MVA* for the thermal assessment.

For steady-state voltage studies, the load in the studied area was modeled as voltage dependant prior to the tap changer response (P modeled as 50% constant current and 50% constant impedance; Q modeled as 100% constant impedance), and as constant MVA after the transformer tap changers responded.

For transient studies, the load in Ontario was modeled as voltage dependant load: P modeled as 50% constant current and 50% constant impedance; Q modeled as 100% constant impedance.

Base Case Configuration Changes

Details about the base case configuration presented in the Greenfield South SIA are applicable, with the following additions:

- Greenfield South connected to R24C or K23C;
- R24V relocated at Richview TS from A1H1 to A2H2

To reflect the 2009-2010 system configuration, the following major elements have been added to the IESO load flow model:

- Hurontario SS 230 kV on R19/21T and V72/73R;
- Sithe Goreway connected to V72/73R;
- Portlands Energy Centre connected to Hearn TS;
- Claireville TS reconfigured as per SIA CAA ID 2006-220;
- V75R in service;
- 400 MVA of shunt capacitors connected to Middleport TS;
- Two 245 MVA shunt capacitors connected to Orangeville TS and Detweiler TS;
- Leaside, Hearn, Sithe Goreway, Claireville 230kV and Richview switchyards operated split.

Load Flow Set-up

Details about the load flow set up presented in the Greenfield South SIA are applicable. As the SIA has not identified concerns under the light load conditions, only the peak load scenario was used in this Addendum.

Summary of Peak Load Scenario (Greenfield South O/S):

Manby-Cooksville Area Load	1,533 MW	Manby E 230 kV Load	63.5 MW
Greenfield South load	8 MW	Manby E 115 kV Load	373.7 MW
Manby-Cooksville Area Demand	1,560 MW	Manby W 230 kV Load	174.0 MW
Manby-Cooksville Area Losses	19 MW	Manby W 115 kV Load	389.2 MW
Toronto Zone Load	10,616 MW	Total Ontario Load	28210 MW
Toronto Zone Losses	113 MW	Total Ontario Losses	855 MW
FETT	3,750 MW	FS	1,185 MW

5.4 Thermal Loading Assessment

The thermal assessment was conducted as per the *Ontario Resource and Transmission Assessment Criteria (ORTAC)* document. Details about how the analyses are conducted were presented in the Greenfield South SIA and are applicable to the Addendum.

Based on the short-circuit analysis presented in chapter 4 of this report, short-circuit levels are approaching the maximum levels at Manby 118 kV switchyards when Greenfield South is in service, without yet being exceeded, and Cooksville switchyard is not required to be operated split.

Therefore, this Addendum covers only the solid bus configuration at Cooksville TS. Load flow analyses were conducted for the scenarios presented in Table 13 below.

Table 13 – Load Flow Scenarios

	<i>Load Level</i>	<i>Greenfield South Status</i>	<i>Cooksville Switchyard</i>
1.1	2009 Peak Load	Out-of-service	Solid
1.2	2009 Peak Load	In-Service on R24C	Solid
1.3	2009 Peak Load	In-Service on K23C	Solid

The contingencies simulated during the analysis are presented in Table 14 below. Contingencies 17 and 18 were added to the list used in the initial SIA.

Table 14 - Contingencies

<i>Single Contingencies:</i>		<i>Double Contingencies:</i>	
1.	Loss of R1K	8.	Loss of R1K + R2K ²
2.	Loss of R13K ¹	9.	Loss of R13K ¹ + R15K
3.	Loss of R2K ²	10.	Loss of K21C + K23C ⁴
4.	Loss of R15K	11.	Manby West A1L2 breaker failure ⁵
5.	Loss of R24C ³	12.	R1K out + loss of R13K ¹
6.	Loss of K21C	13.	R15K out + loss of R2K ²
7.	Loss of K23C ⁴	14.	K21C out + loss of R2K ² (similar for loss of R15K)
		15.	K23C out + loss of R13K ¹ (similar for loss of R1K)
		16.	R2K out + loss of R24C ³ (similar for R15K out)
		17.	R13K out + loss of R24C ³ (similar for R1K out)
		18.	R2K out + loss of K23C ⁴ (similar for R15K out)

Notes:

¹ Fault on R13K removes Richview H2 bus, including Richview SC21

² Fault on R2K removes Richview A1 bus, including Richview SC22

³ Fault on R24C removes Greenfield South, when connected to R24C

⁴ Fault on K23C removes Greenfield South, when connected to K23C

⁵ Manby West A1L2 breaker-failure removes Manby SC21 + T3 + T13 + T1 + R2K + Richview A1 bus, including SC22

The detailed results for the thermal loading assessment for each scenario are shown in a tabular format in *Appendix C* of this report. For each analyzed scenario, there are two tables: one reflects the results for single contingency simulations, and the second represents the results for double contingency simulations.

The following thermal assessment conclusions are to be mentioned:

(a) Scenario 1.1 – 2009 Peak Load – Greenfield South out of service (end of 2009 configuration)

Claireville autotransformers were loaded very close to their continuous ratings pre-contingency, with Claireville T14 loaded at 99% of its continuous rating.

There were two single contingencies resulting in line overloading. The loss of R2K resulted in R15K loaded slightly above its LTE rating: 675 MVA flow versus 661 MVA LTE rating. Similarly, R2K was slightly overloaded following the loss of R15K. This potential overloading is a known deficiency in the Richview – Manby area which can be addressed by the proposed generation.

Any double contingency removing R2K or R15K resulted in the overloading of the remaining line supplying Manby West and Horner TS. Moreover, when both R2K and R15K are out of service, K21C loading exceeded the LTE rating. By interrupting 150 MW of load, which is acceptable for a two line outage, the loadings can be reduced below the LTE ratings, and the load security criteria are respected.

(b) Scenario 1.2 – 2009 Peak Load – Greenfield South in service on R24C– Cooksville TS solid (proposed)

With the injection of power from Greenfield South, the loadings on Claireville autotransformers were slightly alleviated pre-contingency, with T14 loaded at 96% of its continuous rating.

All single contingencies in the studied area resulted in acceptable flows, as R2K and R15K loading was relieved by the new power injection into the area.

Most of the results from the double element contingencies improved from scenario 1.1. However, R2K+R15K, K21C+R2K and R2K+R24C contingencies resulted in overloadings similar to the previous scenario, as these contingencies removed the positive contribution of Greenfield South to the overloaded lines. Symmetrical contingencies K21C+R15K and R15K+R24C would result in similar results. By interrupting 150 MW of load, which is acceptable for a two line outage, the loadings can be reduced below the LTE ratings, and the load security criteria are respected.

(c) Scenario 1.3 – 2009 Peak Load – Greenfield South in service on K23C – Cooksville TS solid (alternate connection)

Similar to scenario 1.2, the loadings on Claireville autotransformers were slightly alleviated pre-contingency by the new power injection.

Other than R24C and K23C contingencies, all other single contingencies resulted in flows similar to the flows recorded in the previous scenario. All the flows were within acceptable limits.

The results from the double element contingencies were similar to those from scenario 1.2, with the R24C being replaced by K23C in critical contingencies: R2K+R15K, K21C+R2K and R2K+K23C contingencies resulted in overloadings, as well as symmetrical contingencies K21C+R15K and R15K+K23C. Again, by interrupting 150 MW of load, which is acceptable for a two line outage, the loadings can be reduced below the LTE ratings, and the load security criteria are respected.

(d) The comparison between the three peak load scenarios pre-contingency is presented in Table 15 below. The distribution factors (DF) for Greenfield South's output were calculated for all the elements of interest, including all 230 kV circuits emanating from Richview and the 500 / 230 kV autotransformers in the GTA. The distribution factors were determined during a scenario with Nanticoke generation being reduced when generation from Greenfield South was increased.

As expected, the distribution factors were higher for the circuits connected to Richview A2H2 buses, where circuit R24C connects, opposed to circuits connected to Richview A1H1 buses. All GTA autotransformers will benefit from this new generation, with Claireville autotransformers receiving about 30% of the generation.

Table 15 Peak Load - Pre-contingency Summaries

Monitored Element			Greenfield South O/S Pre-contingency - R24C on Richview A1H1 bus (West)			Greenfield South O/S Pre-contingency - R24C on Richview A2H2 bus (East)			Greenfield South on R24C Pre-contingency Cookeville solid				Greenfield South on K23C Pre-contingency Cookeville solid					
			MW	MVA	MVA	MW	MVA	MVA	MW	MVA	MVA	DF%	MW	MVA	MVA	DF%		
Richview- Manby- Cookeville Area 230 kV Circuits	R1K	Richview TS	Manby E TS	320	-77	329	288	-80	299	261	-80	273	-8	200	-75	214	-27	
	R13K	Richview TS	Manby E TS	317	-76	326	286	-79	296	259	-80	271	-8	198	-74	212	-27	
	R2K	Richview TS	Manby W TS	370	-57	375	391	-56	395	328	-55	333	-19	332	-55	336	-18	
	R15K	Richview TS	Manby W TS	372	-57	377	393	-56	397	330	-55	335	-19	334	-55	338	-18	
	R24C	Richview TS	Greenfield S	180	2	180	202	5	202	51	12	52	-46	167	4	167	-11	
		Greenfield S	Applewood Jct	172	-3	172	193	0	193	372	-12	373	54	166	4	166	-8	
		Applewood Jct	Cookeville TS	172	-3	172	193	0	193	372	-15	372	54	166	4	166	-8	
		Total Manby Area Inflow			1560	-265	1587	1560	-266	1590	1230	-258	1264	-100	1230	-256	1266	-100
	K21C	Manby W TS	Applewood Jct	32	89	94	73	89	115	-52	101	114	-38	-46	100	110	-36	
		Applewood Jct	Cookeville	32	91	96	73	91	117	-52	103	116	-38	-46	103	112	-36	
K23C	Manby E TS	Greenfield S	199	76	213	136	72	154	82	75	112	-16	-40	89	97	-53		
	Greenfield S	Applewood Jct	199	76	213	136	72	154	82	76	112	-16	282	59	288	44		
	Applewood Jct	Cookeville TS	199	75	213	136	72	154	82	76	112	-16	282	57	287	44		
B15C	Cookeville TS	Oakville TS	133	44	140	133	44	140	133	44	140	0	133	44	140	0		
B16C	Cookeville TS	Oakville TS	134	52	144	134	52	144	134	51	143	0	134	51	143	0		
Out of Richview 230 kV Circuits			P21R	-61	56	83	-47	56	73	-38	65	75	3	-38	65	76	3	
			C4R	-71	42	83	-63	42	75	-56	44	71	2	-56	44	71	2	
		Richview TS	C5R	-97	27	101	-88	26	92	-81	29	86	2	-82	29	87	2	
		AH1	V71R	-302	45	305	-280	46	284	-264	46	268	5	-265	46	269	4	
			V74R	-227	46	231	-202	47	208	-188	47	194	4	-189	47	195	4	
			V75R	-297	48	301	-275	49	279	-260	49	264	5	-261	49	265	4	
			R14T	-28	93	97	-9	92	93	21	85	87	9	20	85	87	9	
			R17T	-28	92	97	-9	92	92	20	85	87	9	19	85	87	9	
			P22R	-7	53	54	-20	54	57	-3	62	62	5	-2	62	62	5	
			C18R	32	37	49	23	37	43	35	39	52	4	36	39	53	4	
		Richview TS	C20R	24	43	49	15	43	45	28	44	52	4	28	44	52	4	
		AH2	V72R	-235	50	240	-255	49	260	-227	49	232	9	-226	49	231	9	
			V73R	-279	54	284	-296	54	301	-269	53	275	8	-269	53	274	8	
			V76R	-252	53	257	-270	53	275	-243	52	248	8	-242	52	247	9	
		R19T	10	115	115	-19	116	118	22	108	110	13	23	108	110	13		
		R21T	-12	118	119	-33	119	123	6	112	112	12	7	111	112	12		
500/230 kV Autotransformers	Trafalgar	T15	712	217	745	712	216	744	706	217	739	-2	706	217	739	-2		
	Trafalgar	T14	703	219	736	702	218	735	697	219	731	-2	697	219	731	-2		
		Total	1416	435	1481	1414	434	1479	1403	436	1470	-3	1403	436	1470	-3		
	Claireville	T13	711	200	739	699	197	726	678	202	707	-6	678	202	708	-6		
	Claireville	T14	720	222	754	708	218	741	686	223	722	-7	687	223	722	-6		
	Claireville	T15	678	198	707	692	201	721	662	204	693	-9	662	205	693	-9		
	Claireville	T16	631	183	657	644	185	670	616	189	644	-8	615	189	644	-9		
		Total	2741	802	2856	2743	801	2858	2642	818	2766	-31	2642	818	2766	-31		
	Parkway	T3	578	204	613	578	204	613	558	163	581	-6	558	163	581	-6		
	Parkway	T4	575	213	613	575	213	614	556	172	581	-6	556	172	581	-6		
		Total	1154	417	1227	1154	417	1227	1113	335	1162	-12	1113	335	1163	-12		
	Cherrywood	T15	557	209	595	560	210	598	549	218	591	-3	549	218	591	-3		
	Cherrywood	T16	560	209	598	563	209	601	552	218	594	-3	552	218	593	-3		
	Cherrywood	T14	502	210	544	499	210	541	490	219	537	-3	490	219	537	-3		
Cherrywood	T17	495	205	536	493	205	533	484	214	529	-3	484	214	529	-3			
	Total	2114	833	2273	2114	834	2273	2075	868	2250	-12	2075	868	2250	-12			

5.5 Voltage Assessment

The voltage assessment was conducted as per the *Ontario Resource and Transmission Assessment Criteria (ORTAC)* document. Details about how the analyses were conducted were presented in the initial SIA.

For steady state voltage performance, load flow analysis were conducted for the peak load scenarios presented in Table 13, and all contingencies presented in Table 14 above were simulated.

The detailed results of the voltage assessment are presented in the Appendix D of this report.

The voltage assessment concluded that the pre-contingency and post-contingency voltages were within acceptable ranges.

Even without injecting reactive power into the system, but just offsetting the reactive power losses in the step-up transformers, the voltages in the GTA and Southwestern Ontario improved under the peak load conditions as a result of the addition of generation from Greenfield South. The pre-contingency voltage profiles are presented in Figure 4 and Figure 5, for the 500 kV system and 230 kV system, respectively.

Figure 4 – 500 kV Voltage Profiles

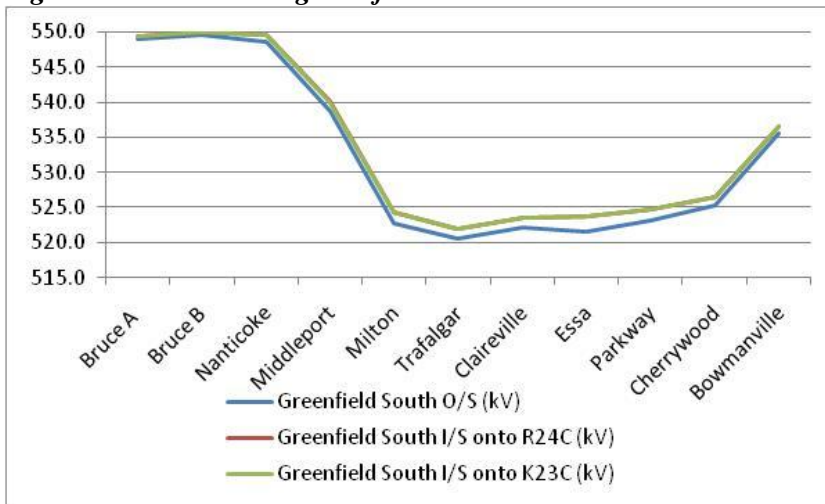
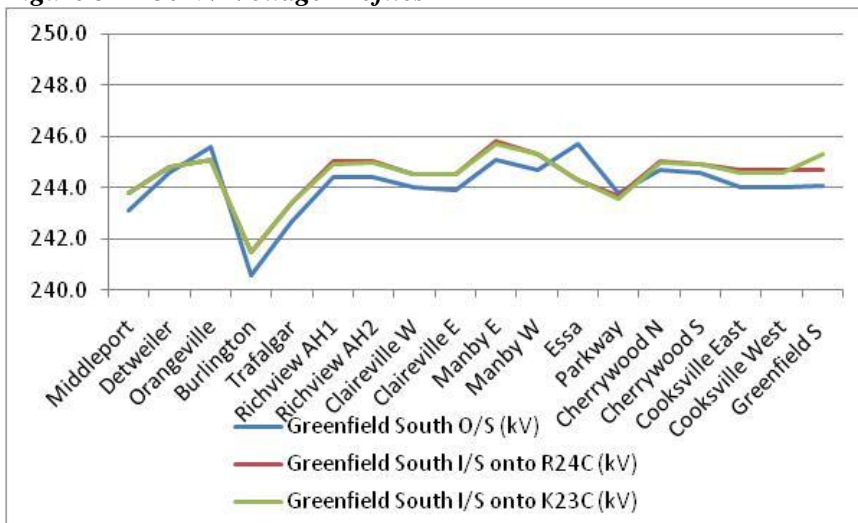

Figure 5 – 230 kV Voltage Profiles



5.6 Control Systems Assessment

In addition to the testing of the control systems conducted in the Greenfield South SIA, additional testing was done for the excitation systems to evaluate the negative field voltage (Efd) response time for the Efd following a 5% negative reference voltage (Vref) change.

As per Market Rules, the two generation units shall be equipped with an excitation system with:

- a voltage response time not longer than 50 ms for a voltage reference step change not to exceed 5%. The voltage response time is defined as the time in seconds for the excitation voltage to attain 95% of the difference between the ceiling voltage and rated load field voltage;
- a positive ceiling voltage of at least 200% of the rated field voltage, and a negative ceiling voltage of at least 140% of the rated field voltage.

For the two generators, the response time requirement for the 5% negative Vref change is calculated below.

Table 16 – Excitation Voltage Response Time for 5% negative Vref change

	G1	G2
Efd rated (pu)	2.566	3.057
Efd initial (t=0) (pu)	1.080	1.244
Efd required ceiling(-) (pu)	-3.59	-4.28
0.95 x (Efd ceiling(-) – Efd rated) (pu)	-5.85	-6.96
Efd required in 50 ms (pu)	-4.77	-5.72
Efd max in 50 ms (pu)	-6.1	-1.79
Voltage Response Time (ms)	4 ms	U/A

The testing results are presented in Appendix E, figure E-1 and E-2 for G1 and G2 excitation systems, respectively.

While the G1 excitation system was found to meet the Market Rules requirements, the G2 excitation system could not meet the negative Efd response time requirements for a 5% negative Vref change under the open circuit test.

The Applicant has to review the G2 excitation system model and its parameters and ensure that it meets the Market Rules requirements, including those for negative Efd ceiling and the response time for a negative Vref change, before the final approval for connection is granted.

It is recommended the Applicant to provide the IESO with the revised G2 excitation system model and its parameters as soon as they become available, to allow the testing of the excitation system against the Market Rule requirements.

5.7 Transient Stability Analysis

To evaluate transient stability of the proposed generators, and the impact on the existing generators, a comprehensive number of fault simulations were conducted. The disturbances which were simulated and their explanations are shown in Table 17 below.

While most of the contingencies were simulated for both possible connections, some disturbances were simulated for either R24C or K23C plant connection where they were not critical for the alternate connection.

Table 17 – Transient System Disturbances

Contingencies	
1.	R13K: three phase fault at Richview TS (Richview SC21+T7 removed by configuration)
2.	R1K + R2K: phase-to-ground fault at Richview TS (Richview SC22+T2+T8 removed by configuration)
3.	K21C: three phase fault at Cooksville TS (Cooksville T4+T6 removed by configuration)
4.	K21C and K23C: phase-to-ground fault at Cooksville TS (Cooksville T4+T6 removed by configuration) -- GFS on R24C only
5.	K21C and K23C: Cooksville L21L23 Breaker Failure: K21C phase-to-ground fault at Cooksville (delayed tripping - Cooksville T4+T6 removed by configuration)) - GFS on R24C only
6.	R1K+R19T: RichviewA2L19 Breaker Failure: R1K phase-to-ground fault at Richview (delayed tripping -Richview T8 removed by configuration))
7.	R13K+P22R: RichviewH2L22 Breaker Failure: R13K phase-to-ground fault at Richview (delayed tripping) (Richview SC21+T7 removed by configuration)
8.	R24C LEO at Richview: R1K three-phase fault at Richview with Richview L2L72 Breaker O/S (Richview T8 removed by configuration) - GFS on R24C only
9.	K23C LEO at Manby E: R1K three-phase fault at Richview with Manby E H2L23 Breaker O/S (Richview T8 removed by configuration) - GFS on K23C only
10.	R1K loss without a fault (small disturbance)

The Appendix F of this report presents three diagrams for each simulated contingency, namely *G1 Response*, *G2 Response* and *Major Generator Angles*, for a total of 48 diagrams.

It can be observed from the diagrams in Appendix F that the power system and the new generation facilities will remain stable with acceptable damping for all examined fault conditions and generation connectivity.

– End of Section –

-intentionally left blank-

Appendix A

Short Circuit Results

Table A-1: Shortcircuit Results - Greenfield South GS connected to R24C

Bus Number	Bus Name	Base volt (kV)	Max volt (pu)	Breaker Time (s)	Symmetrical (kA)			Asymmetrical (kA)		Breaker Rating	
					3-phase	L-G	DL-G	3-phase	L-G	Sym	Asym
4131	GFSHV	220	1.136	0.025	32.806	29.065	31.263	41.503	38.312	62.92	
4133	GFSLV2	13.8	1.06	0.033	88.861	0.002	76.955	122.927	0.604		
4132	GFSLV1	16.5	1.06	0.033	107.17	0.002	92.812	147.716	0.74		
4147	COOK PHJ	220	1.136	0.025	45.186	40.832	43.337	56.681	52.96	63	76
4146	COOK B16	220	1.136	0.025	45.186	40.832	43.337	56.681	52.96	63	76
3107	MANBY E	220	1.136	0.025	44.767	42.228	43.615	55.639	54.51	70	80.4
3108	MANBY W	220	1.136	0.025	47.082	44.937	46.091	58.185	58.284	70	80.4
3302	MANBY E	118.05	1.076	0.033	27.27	32.4	30.917	35.215	43.354	38.8	45.5
3303	MANBY W	118.05	1.076	0.033	27.689	32.987	31.48	35.713	44.183	38.8	45.5
4103	RICH AH2	220	1.136	0.025	62.845	60.531	61.759	81.14	78.221	69.5	83.4
4105	RICH AH1	220	1.136	0.025	60.771	56.814	59.001	76.935	70.77	69.5	83.4
4000	CLAIRVIL	500	1.1	0.025	54.605	51.272	53.104	72.267	70.401	80	96
4100	CLAIRVIL	220	1.136	0.025	60.823	63.131	62.057	83.322	89.739	80	96
4199	CLAIRVLESPLT	220	1.136	0.025	60.858	63.443	62.252	82.812	89.589	80	96
2108	PARKWAY	220	1.136	0.025	64.54	70.535	68.086	88.695	100.463	80	104
2100	CHERYDK1	220	1.136	0.025	48.181	48.756	48.474	67.514	68.375	60	70.2
2101	CHERYDK2	220	1.136	0.025	44.564	47.762	46.383	62.73	68.739	60	70.2
2102	CHERYDK3	220	1.136	0.025	44.319	47.894	46.386	62.435	69.965	60	70.2
2103	CHERYDK4	220	1.136	0.025	45.583	46.751	46.194	64.114	66.967	60	70.2
3301	LEAS EJ	118.05	1.076	0.033	31.196	34.014	32.854	39.008	44.116	39.3	45.5
3305	LEAS KP	118.05	1.076	0.033	31.891	34.574	33.452	40.012	45.277	39.3	45.5
4138	HURONT1	220	1.136	0.025	30.683	29.085	29.952	37.451	34.586	63	76
4139	HURONT2	220	1.136	0.025	30.181	28.877	29.576	37.058	34.432	63	76
4163	HURONT3	220	1.136	0.025	30.683	29.085	29.952	37.451	34.586	63	76
4164	HURONT4	220	1.136	0.025	30.181	28.877	29.576	37.058	34.432	63	76
4104	TRAFALGA	220	1.136	0.025	66.389	65.226	65.825	85.681	89.313	80	96
5102	BURLINGT	220	1.136	0.025	52.616	44.255	49.406	62.981	56.417	63	76
4003	MILTON	500	1.1	0.025	44.311	38.354	41.933	57.098	48.461	63	76

Table A-2: Shortcircuit Results - Greenfield South GS connected to K23C

Bus Number	Bus Name	Base volt (kV)	Max volt (pu)	Breaker Time (s)	Symmetrical (kA)			Asymmetrical (kA)		Breaker Rating	
					3-phase	L-G	DL-G	3-phase	L-G	Sym	Asym
4131	GFSHV	220	1.136	0.025	31.962	27.928	30.33	39.754	36.526	62.92	
4133	GFSLV2	13.8	1.06	0.033	88.725	0.002	76.838	122.486	0.598		
4132	GFSLV1	16.5	1.06	0.033	106.959	0.002	92.629	147.002	0.731		
4147	COOK PHJ	220	1.136	0.025	45.037	40.584	43.154	56.445	52.526	63	76
4146	COOK B16	220	1.136	0.025	45.037	40.584	43.154	56.445	52.526	63	76
3107	MANBY E	220	1.136	0.025	45.794	43.612	44.789	57.351	56.502	70	80.4
3108	MANBY W	220	1.136	0.025	46.993	45.041	46.084	58.053	58.362	70	80.4
3302	MANBY E	118.05	1.076	0.033	27.463	32.679	31.185	35.64	43.922	38.8	45.5
3303	MANBY W	118.05	1.076	0.033	27.673	32.993	31.487	35.683	44.173	38.8	45.5
4103	RICH AH2	220	1.136	0.025	62.898	60.412	61.737	81.099	77.965	69.5	83.4
4105	RICH AH1	220	1.136	0.025	60.714	56.636	58.896	76.837	70.574	69.5	83.4
4000	CLAIRVIL	500	1.1	0.025	54.602	51.256	53.096	72.235	70.365	80	96
4100	CLAIRVIL	220	1.136	0.025	60.845	63.122	62.062	83.294	89.699	80	96
4199	CLAIRVLESPLT	220	1.136	0.025	60.829	63.39	62.209	82.747	89.502	80	96
2108	PARKWAY	220	1.136	0.025	64.537	70.529	68.081	88.67	100.444	80	104
2100	CHERYDK1	220	1.136	0.025	48.182	48.756	48.475	67.511	68.372	60	70.2
2101	CHERYDK2	220	1.136	0.025	44.565	47.763	46.383	62.727	68.737	60	70.2
2102	CHERYDK3	220	1.136	0.025	44.315	47.89	46.382	62.427	69.957	60	70.2
2103	CHERYDK4	220	1.136	0.025	45.58	46.749	46.192	64.108	66.963	60	70.2
3301	LEAS EJ	118.05	1.076	0.033	31.196	34.014	32.854	39.008	44.115	39.3	45.5
3305	LEAS KP	118.05	1.076	0.033	31.891	34.574	33.452	40.011	45.277	39.3	45.5
4138	HURONT1	220	1.136	0.025	30.683	29.072	29.947	37.447	34.572	63	76
4139	HURONT2	220	1.136	0.025	30.185	28.868	29.574	37.059	34.42	63	76
4163	HURONT3	220	1.136	0.025	30.683	29.072	29.947	37.447	34.572	63	76
4164	HURONT4	220	1.136	0.025	30.185	28.868	29.574	37.059	34.42	63	76
4104	TRAFALGA	220	1.136	0.025	66.383	65.215	65.817	85.664	89.292	80	96
5102	BURLINGT	220	1.136	0.025	52.614	44.254	49.404	62.977	56.414	63	76
4003	MILTON	500	1.1	0.025	44.309	38.349	41.93	57.085	48.451	63	76

Notes:

1. The station breaker ratings reflect the minimum break ratings at each station.

– End of Section –

Appendix B

Circuit Ratings

System Impact Assessment Addendum Greenfield South GS – Appendix B

Table B-1: IESO calculated data from Transmission Circuit Ampacities:

230kV Line Ratings			Ratings at 35°C Ambient: 4km/hr wind: MVA at 240kV						
Circuit	Conductor (Limiting Section)	Sag Temp	Continuous at 93°C or Sag Temperature, if lower		Long-Term 'Emergency' at 127°C or Sag Temperature, if lower				15-min LTR at Sag Temperature
R1K: Richview to Manby East									
Richview TS to Str 3	1843.2kcmil 72/7	93/127°C	1350A	561MVA	1790A**	744MVA**	2160A	898MVA	Pre-load of 1350A
Str 3 to Str 28	1443.7kcmil 56/19	134°C	1160A	482MVA	1590A	661MVA	1930A	802MVA	Pre-load of 1160A
Str 28 to Manby East TS	1843.2kcmil 72/7	93/127°C	1350	561MVA	1790A**	744MVA**	2160A	898MVA	Pre-load of 1350
R13K: Richview to Manby East									
Richview TS to Str 3	1843.2kcmil 72/7	93/127°C	1350A	561MVA	1790A**	744MVA**	2160A	898MVA	Pre-load of 1350A
Str 3 to Str 28	1443.7kcmil 56/19	134°C	1160A	482MVA	1590A	661MVA	1930A	802MVA	Pre-load of 1160A
Str 28 to Manby East TS	1843.2kcmil 72/7	93/127°C	1350	561MVA	1790A**	744MVA**	2160A	898MVA	Pre-load of 1350A
R2K: Richview to Manby West									
Richview TS to Str 3	1843.2kcmil 72/7	93/127°C	1350A	561MVA	1790A**	744MVA**	2160A	898MVA	Pre-load of 1350A
Str 3 to Str 28	1443.7kcmil 56/19	134°C	1160A	482MVA	1590A	661MVA	1930A	802MVA	Pre-load of 1160A
Str 28 to Str 31	1843.2kcmil 72/7	93/127°C	1350	561MVA	1790A**	744MVA**	2160A	898MVA	Pre-load of 1350A
Str 31 to Manby East TS	1843.2kcmil 72/7	93/127°C	1350	561MVA	1790A**	744MVA**	2160A	898MVA	Pre-load of 1350A
R15K: Richview to Manby West									
Richview TS to Str 3	1843.2kcmil 72/7	93/127°C	1350A	561MVA	1790A**	744MVA**	2160A	898MVA	Pre-load of 1350A
Str 3 to Str 28	1443.7kcmil 56/19	134°C	1160A	482MVA	1590A	661MVA	1930A	802MVA	Pre-load of 1160A
Str 28 to Str 31	1843.2kcmil 72/7	93/127°C	1350	561MVA	1790A**	744MVA**	2160A	898MVA	Pre-load of 1350A
Str 31 to Manby East TS	1843.2kcmil 72/7	93/127°C	1350	561MVA	1790A**	744MVA**	2160A	898MVA	Pre-load of 1350A

System Impact Assessment Addendum Greenfield South GS – Appendix B

230kV Line Ratings			Ratings at 35°C Ambient: 4km/hr wind: MVA at 240kV						
Circuit	Conductor (Limiting Section)	Sag Temp	Continuous at 93°C or Sag Temperature, if lower	Long-Term 'Emergency' at 127°C or Sag Temperature, if lower	15-min LTR at Sag Temperature				
R24C: Richview TS to Cooksville TS									
Richview TS to Applewd Jct	2776.3kcmil 84/19	127°C	1750A	727MVA	2330A	968MVA	2980A	1238MVA	Pre-load of 1750A
Applewd Jct to Cooksville	1843.2kcmil 72/7	93/116°C	1350A	561MVA	1660A**	690MVA**	1940A	806MVA	Pre-load of 1350A
B15C: Cooksville TS to Oakville TS									
Cooksville to Lorne P	1843.2kcmil 72/7	93/127°C	1350A	561MVA	1790A**	744MVA**	2160A	898MVA	Pre-load of 1350A
Lorne P to Ford CTS Jct	1843.2kcmil 72/7	93/127°C	1350A	561MVA	1790A**	744MVA**	2160A	898MVA	Pre-load of 1350A
Ford CTS Jct to Oakville	1843.2kcmil 72/7	93/127°C	1350A	561MVA	1790A**	744MVA**	2160A	898MVA	Pre-load of 1350A
B16C: Cooksville TS to Oakville TS									
Cooksville to Lorne P	1843.2kcmil 72/7	93/127°C	1350A	561MVA	1790A**	744MVA**	2160A	898MVA	Pre-load of 1350A
Lorne P to Ford CTS Jct	1843.2kcmil 72/7	93/127°C	1350A	561MVA	1790A**	744MVA**	2160A	898MVA	Pre-load of 1350A
Ford CTS Jct to Oakville	1843.2kcmil 72/7	93/127°C	1350A	561MVA	1790A**	744MVA**	2160A	898MVA	Pre-load of 1350A
K21C: Manby West TS to Cooksville TS									
Manby TS to Applewd Jct (former L21K and L22K)	1843.2kcmil 72/7 1843.2kcmil 72/7	93/127°C 93/116°C	1350A 1350A	561MVA 561MVA	1790A** 1660A**	744MVA** 690MVA**	2160A 1940A	898MVA 806MVA	Pre-load of 1350A
Applewd Jct to Cooksville	New cable								
K23C: Manby East TS to Cooksville TS									
Manby TS to Applewd Jct (former L23CK)	2776.3kcmil 84/19	116°C	1680A	702MVA	2090A	868MVA	2590A	1076MVA	Pre-load of 1680A
Applewd Jct to Cooksville (former L23CK)	1843.2kcmil 72/7	93/116°C	1350A	561MVA	1660A**	690MVA**	1940A	806MVA	Pre-load of 1350A

Note: ** Limited to 50 hours per year

System Impact Assessment Addendum Greenfield South GS – Appendix B

Table B-2: Hydro One data sent by email (operational ratings)

Circuit	Conductor (Limiting Section)	Sag Temp	Continuous	Assumed LTE=Cont	15-min LTR at Sag Temperature
K21C: Manby West TS to Cooksville TS					
Manby TS to Applewd Jct			1420A	590MVA	1420A 590MVA
Manby TS to Applewd Jct			1420A	590MVA	1420A 590MVA
Applewd Jct to Cooksv PHJ	cable		1558A	684MVA	1558A 684MVA
Cooksv PHJ to Cooksville			1750A	727MVA	1750A 727MVA
K23C: Manby East TS to Cooksville TS					
Manby TS to Applewd Jct			1420A	590MVA	1420A 590MVA
Applewd Jct to Cooksville (former L23CK)			1420A	590MVA	1420A 590MVA

The lowest rating was used in the analysis where there is discrepancy between H1 and the IESO ratings

- End of Section -

Appendix C

Thermal Analysis Results

System Impact Assessment Addendum Greenfield South GS – Appendix C

Table C-1

Scenario 1.1 Peak Load - Greenfield South out of service, Cooksville solid
Single Contingencies

Monitored Element				Continuous Rating (CR)			Pre-contingency				Loss of R1K		Loss of R13K + Richview H2 bus (SC21)		Loss of R2K + Richview A1 bus (SC22)		Loss of R15K		Loss of R24C		Loss of K21C		Loss of K23C	
				MVA	MVA	MVA	MW	MVA _r	MVA	%CR	MVA	%LTE	MVA	%LTE	MVA	%LTE	MVA	%LTE	MVA	%LTE	MVA	%LTE	MVA	%LTE
Richview- Manby- Cooksville Area	R1K	Richview TS	Manby E TS	482	661	802	288	-80	299	62	0	0	500	76	326	49	331	50	352	53	313	47	250	38
	R13K	Richview TS	Manby E TS	482	661	802	286	-79	296	61	498	75	0	0	323	49	328	50	349	53	310	47	248	38
	R2K	Richview TS	Manby W TS	482	661	802	391	-56	395	82	420	64	417	63	0	0	672	102	436	66	370	56	428	65
	R15K	Richview TS	Manby W TS	482	661	802	393	-56	397	82	422	64	419	63	675	102	0	0	439	66	372	56	430	65
	R24C	Richview TS	Greenfield S	727	969	1239	202	5	202	28	247	25	246	25	253	26	250	26	0	0	238	25	271	28
		Greenfield S	Applewood Jct	727	969	1201	193	0	193	27	239	25	239	25	244	25	242	25	0	0	228	24	261	27
230 kV Circuits		Applewood Jct	Cooksville TS	561	690	806	193	0	193	34	239	35	239	35	244	35	242	35	0	0	228	33	261	38
	K21C	Manby W TS	Applewood Jct	561	590	806	73	89	115	21	143	24	184	31	49	8	93	16	179	30	0	0	191	32
		Applewood Jct	Cooksville	648	648	898	73	91	117	18	144	22	185	29	50	8	95	15	180	28	0	0	192	30
	K23C	Manby E TS	Greenfield S	590	590	1010	136	72	154	26	106	18	75	13	234	40	218	37	258	44	225	38	0	0
		Greenfield S	Applewood Jct	590	590	1010	136	72	154	26	106	18	75	13	233	40	217	37	257	44	224	38	0	0
		Applewood Jct	Cooksville TS	561	590	806	136	72	154	27	106	18	76	13	233	39	217	37	257	44	224	38	0	0
B15C	Cooksville TS	Oakville TS	561	744	898	133	44	140	25	140	19	140	19	141	19	140	19	140	19	140	19	140	19	
B16C	Cooksville TS	Oakville TS	561	744	898	134	52	144	26	144	19	144	19	145	19	144	19	144	19	144	19	144	19	
500/230 kV Autotransformers		Trafalgar	T15	939	1155	1499	712	216	744	79	744	64	750	65	750	65	744	64	744	64	743	64	744	64
		Trafalgar	T14	837	1019	1244	702	218	735	88	736	72	742	73	742	73	736	72	736	72	735	72	736	72
		Claireville	T13	750	840	1245	699	197	726	97	731	87	737	88	727	87	717	85	734	87	719	86	733	87
		Claireville	T14	750	840	1245	708	218	741	99	745	89	753	90	743	88	732	87	748	89	733	87	748	89
		Claireville	T15	750	840	1245	692	201	721	96	716	85	726	86	740	88	734	87	711	85	730	87	713	85
		Claireville	T16	750	840	1245	644	185	670	89	665	79	675	80	688	82	682	81	661	79	678	81	663	79
		Parkway	T3	953	1141	1499	578	204	613	64	613	54	621	54	622	54	615	54	613	54	614	54	613	54
		Parkway	T4	953	1141	1499	575	213	614	64	614	54	621	54	622	55	615	54	613	54	614	54	614	54
		Cherrywood	T15	750	840	1245	560	210	598	80	597	71	601	71	604	72	601	72	596	71	600	71	596	71
		Cherrywood	T16	750	840	1245	563	209	601	80	600	71	603	72	606	72	604	72	599	71	603	72	599	71
		Cherrywood	T14	750	840	1245	499	210	541	72	542	65	544	65	543	65	540	64	543	65	539	64	543	65
		Cherrywood	T17	1122	1315	1362	493	205	533	48	534	41	537	41	535	41	532	40	535	41	532	40	535	41

System Impact Assessment Addendum Greenfield South GS – Appendix C

Table C-2

Scenario 1.1 Peak Load - Greenfield South out of service, Cookeville solid
Double Contingencies

Monitored Element	Continuous Rating (CR)			Long Term Emergency Rating (LTE)			Pre-contingency				Loss of R1K + R2K + Richview A1 bus (SC22)		Loss of R13K + R15K + Richview H2 bus (SC21)		Loss of K21C + K23C		Loss of Manby SC21+ T3+ T13+ T1+ R2K + Richview A1 bus (SC22) [Manby W A1L2 B/F]		R1K out + loss of R13K		R2K out + loss of R15K		K21C out + loss of R2K (similar for loss of R15K)		K23C out + loss of R13K (similar for loss of R1K)		R2K out + loss of R24C (similar with R15K out)		R13K out + loss of R24C (similar with R1K out)		R2K out + loss of K23C (similar with R15K out)		
	MVA	MVA	MVA	MW	MVA _r	MVA	%CR	MVA	%LTE	MVA	%LTE	MVA	%LTE	MVA	%LTE	MVA	%LTE	MVA	%LTE	MVA	%LTE	MVA	%LTE	MVA	%LTE	MVA	%LTE	MVA	%LTE	MVA	%LTE	MVA	%LTE
Richview- Manby- Cookeville Area	R1K	Richview TS	Manby E TS	482	661	802	288	-80	299	62	0	0	556	84	249	38	324	49	0	0	485	73	312	47	485	73	400	61	615.8	93	245.2	37	
	R13K	Richview TS	Manby E TS	482	661	802	286	-79	296	61	548	83	0	0	246	37	321	49	0	0	480	73	309	47	0	0	396	60	0	0	243	37	
	R2K	Richview TS	Manby W TS	482	661	802	391	-56	395	82	0	0	719	109	370	56	0	0	545	82	0	0	0	0	428	65	0	0	477	72	0	0	
	R15K	Richview TS	Manby W TS	482	661	802	393	-56	397	82	722	109	0	0	372	56	681	103	547	83	0	0	722	109	430	65	764	116	479	72	766	116	
	R24C	Richview TS	Greenfield S	727	969	1239	202	5	202	28	306	32	302	31	462	48	275	28	481	50	469	48	239	25	265	27	0	0	0	0	378	39	
		Greenfield S	Applewood Jct	727	969	1201	193	0	193	27	297	31	294	30	446	46	264	27	476	49	461	48	229	24	257	26	0	0	0	0	366	38	
		Applewood Jct	Cookeville TS	561	690	806	193	0	193	34	297	43	294	43	443	64	263	38	477	69	461	67	229	33	257	37	0	0	0	0	365	53	
	230 kV Circuits	K21C	Manby W TS	Applewood Jct	561	590	806	73	89	115	21	15	3	119	20	0	0	148	25	379	64	601	102	0	0	222	38	58	10	270	46	86	15
			Applewood Jct	Cookeville	648	648	898	73	91	117	18	18	3	121	19	0	0	146	23	378	58	600	93	0	0	223	34	59	9	270	42	88	14
		K23C	Manby E TS	Greenfield S	590	590	1010	136	72	154	26	163	28	125	21	0	0	294	50	492	83	508	86	225	38	0	0	383	65	167	28	0	0
		Greenfield S	Applewood Jct	590	590	1010	136	72	154	26	163	28	125	21	0	0	293	50	490	83	508	86	224	38	0	0	382	65	167	28	0	0	
		Applewood Jct	Cookeville TS	561	590	806	136	72	154	27	163	28	125	21	0	0	291	49	488	83	507	86	224	38	0	0	380	64	167	28	0	0	
B15C		Cookeville TS	Oakville TS	561	744	898	133	44	140	25	141	19	141	19	141	19	140	19	140	19	140	19	141	19	141	19	141	19	140	19	140	19	
B16C	Cookeville TS	Oakville TS	561	744	898	134	52	144	26	145	19	145	19	145	19	144	19	144	19	144	19	145	19	145	19	145	19	144	19	145	19		
500/230 kV Autotransformers	Trafalgar	T15		939	1155	1499	712	216	744	79	751	65	750	65	744	64	755	65	752	65	741	64	751	65	750	65	751	65	751	65	751	65	
	Trafalgar	T14		837	1019	1244	702	218	735	88	742	73	742	73	735	72	747	73	744	73	733	72	743	73	742	73	743	73	743	73	743	73	
	Claireville	T13		750	840	1245	699	197	726	97	732	87	728	87	719	86	735	88	760	91	662	79	731	87	740	88	736	88	748	89	737	88	
	Claireville	T14		750	840	1245	708	218	741	99	747	89	743	89	734	87	752	89	776	92	677	81	747	89	755	90	752	89	763	91	753	90	
	Claireville	T15		750	840	1245	692	201	721	96	736	88	739	88	730	87	747	89	702	84	787	94	736	88	723	86	730	87	713	85	730	87	
	Claireville	T16		750	840	1245	644	185	670	89	684	81	687	82	679	81	694	83	653	78	731	87	684	81	672	80	678	81	663	79	678	81	
	Parkway	T3		953	1141	1499	578	204	613	64	622	55	622	55	614	54	628	55	621	54	615	54	622	55	621	54	622	55	621	54	622	55	
	Parkway	T4		953	1141	1499	575	213	614	64	622	55	622	55	614	54	628	55	621	54	615	54	622	55	621	54	622	55	621	54	622	55	
	Cherrywood	T15		750	840	1245	560	210	598	80	603	72	604	72	600	71	606	72	596	71	611	73	603	72	600	71	601	72	598	71	601	72	
	Cherrywood	T16		750	840	1245	563	209	601	80	605	72	606	72	603	72	609	72	599	71	614	73	606	72	603	72	604	72	601	72	604	72	
Cherrywood	T14		750	840	1245	499	210	541	72	544	65	542	65	539	64	545	65	549	65	527	63	544	65	545	65	545	65	547	65	545	65		
Cherrywood	T17		1122	1315	1362	493	205	533	48	536	41	535	41	532	40	537	41	541	41	519	39	536	41	537	41	537	41	539	41	537	41		

System Impact Assessment Addendum Greenfield South GS – Appendix C

Table C-3

Scenario 1.2 Peak Load - Greenfield South on R24C, Cookville solid Single Contingencies

Monitored Element	Continuous Rating (CR)			Long Term Emergency Rating (LTE)			Pre-contingency				Loss of R1K		Loss of R13K + Richview H2 bus (SC21)		Loss of R2K + Richview A1 bus (SC22)		Loss of R15K		Loss of R24C		Loss of K21C		Loss of K23C				
	MVA	MVA	MVA	MVA	MVA	MVA	MVA	%CR	MVA	%LTE	MVA	%LTE	MVA	%LTE	MVA	%LTE	MVA	%LTE	MVA	%LTE	MVA	%LTE	MVA	%LTE	MVA	%LTE	
	MVA	MVA	MVA	MVA	MVA	MVA	MVA	%CR	MVA	%LTE	MVA	%LTE	MVA	%LTE	MVA	%LTE	MVA	%LTE	MVA	%LTE	MVA	%LTE	MVA	%LTE	MVA	%LTE	
Richview-Manby-Cooksville Area 230 kV Circuits	R1K	Richview TS	Manby E TS	482	661	802	261	-80	273	57	0	0	460	70	295	45	300	45	352	53	251	38	251	38			
	R13K	Richview TS	Manby E TS	482	661	802	259	-80	271	56	455	69	0	0	292	44	297	45	349	53	248	38	249	38			
	R2K	Richview TS	Manby W TS	482	661	802	328	-55	333	69	356	54	352	53	0	0	565	86	436	66	370	56	352	53			
	R15K	Richview TS	Manby W TS	482	661	802	330	-55	335	69	358	54	354	54	572	87	0	0	438	66	372	56	354	54			
	R24C	Richview TS	Greenfield S	727	969	1239	51	12	52	7	92	9	98	10	96	10	93	10	0	0	62	6	103	11			
		Greenfield S	Applewood Jct	727	969	1201	372	-12	373	51	414	43	413	43	415	43	413	43	0	0	353	36	412	43			
		Applewood Jct	Cookville TS	561	690	806	372	-15	372	66	414	60	413	60	414	60	413	60	0	0	352	51	412	60			
	K21C	Manby W TS	Applewood Jct	561	590	806	-52	101	114	20	88	15	134	23	152	26	176	30	179	30	0	0	138	23			
		Applewood Jct	Cookville	648	648	898	-52	103	116	18	90	14	136	21	152	23	177	27	180	28	0	0	140	22			
	K23C	Manby E TS	Greenfield S	590	590	1010	82	75	112	19	101	17	61	10	178	30	160	27	258	44	150	25	0	0			
	Greenfield S	Applewood Jct	590	590	1010	82	76	112	19	101	17	61	10	178	30	160	27	258	44	150	25	0	0				
	Applewood Jct	Cookville TS	561	590	806	82	76	112	20	102	17	62	10	177	30	160	27	258	44	150	25	0	0				
B15C	Cookville TS	Oakville TS	561	744	898	133	44	140	25	140	19	140	19	140	19	140	19	140	19	140	19	140	19	140	19		
B16C	Cookville TS	Oakville TS	561	744	898	134	51	143	26	143	19	144	19	144	19	143	19	144	19	144	19	144	19	143	19		
500/230 kV Autotransformers	Trafalgar	T15		939	1155	1499	706	217	739	79	739	64	745	64	745	65	739	64	750	65	739	64	739	64	739	64	
	Trafalgar	T14		837	1019	1244	697	219	731	87	731	72	737	72	737	72	731	72	742	73	731	72	731	72	731	72	
	Claireville	T13		750	840	1245	678	202	707	94	711	85	717	85	710	84	700	83	739	88	711	85	711	85	711	85	
	Claireville	T14		750	840	1245	686	223	722	96	726	86	732	87	725	86	714	85	754	90	725	86	726	86	726	86	
	Claireville	T15		750	840	1245	662	204	693	92	689	82	699	83	710	84	704	84	716	85	689	82	688	82	688	82	
	Claireville	T16		750	840	1245	616	189	644	86	640	76	649	77	660	79	654	78	666	79	641	76	640	76	640	76	
	Parkway	T3		953	1141	1499	558	163	581	61	581	51	587	51	588	52	582	51	597	52	581	51	581	51	581	51	
	Parkway	T4		953	1141	1499	556	172	581	61	581	51	587	51	588	52	582	51	597	52	581	51	581	51	581	51	
	Cherrywood	T15		750	840	1245	549	218	591	79	590	70	593	71	596	71	593	71	600	71	590	70	590	70	590	70	
	Cherrywood	T16		750	840	1245	552	218	594	79	593	71	596	71	598	71	596	71	603	72	593	71	593	71	593	71	
Cherrywood	T14		750	840	1245	490	219	537	72	538	64	539	64	538	64	535	64	547	65	537	64	538	64	538	64		
Cherrywood	T17		1122	1315	1362	484	214	529	47	530	40	531	40	530	40	527	40	539	41	529	40	530	40	530	40		

System Impact Assessment Addendum Greenfield South GS – Appendix C

Table C-4

Scenario 1.2 Peak Load - Greenfield South on R24C, Cooksville solid Double Contingencies

Monitored Element	Continuous Rating (CR)			Pre-contingency				Loss of R1K + R2K + Richview A1 bus (SC22)		Loss of R13K + R15K + Richview H2 bus (SC21)		Loss of K21C + K23C		Loss of Manby SC21+ T3+ T13+ T1+ R2K + Richview A1 bus (SC22) [Manby W A1L2 B/F]		R1K out + loss of R13K		R2K out + loss of R15K		K21C out + loss of R2K (similar for loss of R15K)		K23C out + loss of R13K (similar for loss of R1K)		R2K out + loss of R24C (similar with R15K out)		R13K out + loss of R24C (similar with R1K out)		R2K out + loss of K23C (similar with R15K out)				
	MVA	MVA	MVA	MW	MVA _r	MVA	%CR	MVA	%LTE	MVA	%LTE	MVA	%LTE	MVA	%LTE	MVA	%LTE	MVA	%LTE	MVA	%LTE	MVA	%LTE	MVA	%LTE	MVA	%LTE	MVA	%LTE			
Richview- Manby- Cooksville Area	R1K	Richview TS	Manby E TS	482	661	802	261	-80	273	57	0	0	506	76	250	38	291	44	0	0	424	64	250	38	487	74	400	61	616	93	247	93
	R13K	Richview TS	Manby E TS	482	661	802	259	-80	271	56	495	75	0	0	248	37	289	44	0	0	420	64	248	37	0	0	396	60	0	0	244	37
	R2K	Richview TS	Manby W TS	482	661	802	328	-55	333	69	0	0	606	92	371	56	0	0	469	71	0	0	0	0	351	53	0	0	477	72	0	0
	R15K	Richview TS	Manby W TS	482	661	802	330	-55	335	69	614	93	0	0	373	56	572	86	471	71	0	0	722	109	353	53	764	116	479	72	630	95
	R24C	Richview TS	Greenfield S	727	969	1239	51	12	52	7	142	15	142	15	201	21	124	13	315	33	267	28	51	5	90	9	0	0	0	0	190	20
230 kV Circuits		Greenfield S	Applewood Jct	727	969	1201	372	-12	373	51	463	48	461	48	445	46	432	45	629	65	588	61	355	37	411	42	0	0	0	0	499	52
		Applewood Jct	Cooksville TS	561	690	806	372	-15	372	66	462	67	460	67	443	64	431	62	630	91	589	85	354	51	410	59	0	0	0	0	498	72
	K21C	Manby W TS	Applewood Jct	561	590	806	-52	101	114	20	109	18	158	27	0	0	213	36	226	38	605	102	0	0	165	28	57	10	270	46	108	18
		Applewood Jct	Cooksville	648	648	898	-52	103	116	18	109	17	160	25	0	0	212	33	226	35	604	93	0	0	167	26	58	9	270	42	109	17
	K23C	Manby E TS	Greenfield S	590	590	1010	82	75	112	19	133	23	83	14	0	0	242	41	496	84	381	65	139	24	0	0	383	65	168	28	0	0
	Greenfield S	Applewood Jct	590	590	1010	82	76	112	19	133	23	83	14	0	0	241	41	494	84	381	64	140	24	0	0	382	65	168	28	0	0	
	Applewood Jct	Cooksville TS	561	590	806	82	76	112	20	134	23	83	14	0	0	241	41	492	83	381	64	140	24	0	0	381	64	168	28	0	0	
B15C	Cooksville TS	Oakville TS	561	744	898	133	44	140	25	140	19	141	19	141	19	140	19	140	19	140	19	140	19	140	19	141	19	141	19	141	19	
B16C	Cooksville TS	Oakville TS	561	744	898	134	51	143	26	144	19	144	19	145	19	145	19	144	19	144	19	144	19	144	19	145	19	145	19	145	19	
	Trafalgar	T15	939	1155	1499	706	217	739	79	745	65	745	65	739	64	750	65	746	65	737	64	746	65	745	64	757	66	757	66	746	65	
	Trafalgar	T14	837	1019	1244	697	219	731	87	737	72	737	72	731	72	742	73	738	72	729	72	738	72	737	72	748	73	749	73	737	72	
500/230 kV Autotransformers		Claireville	T13	750	840	1245	678	202	707	94	713	85	710	84	711	85	718	85	738	88	655	78	723	86	718	85	741	88	754	90	716	85
		Claireville	T14	750	840	1245	686	223	722	96	729	87	725	86	725	86	734	87	753	90	670	80	739	88	733	87	757	90	769	92	732	87
		Claireville	T15	750	840	1245	662	204	693	92	706	84	710	85	689	82	716	85	678	81	745	89	695	83	698	83	735	87	719	86	702	84
		Claireville	T16	750	840	1245	616	189	644	86	656	78	660	79	640	76	665	79	630	75	692	82	646	77	649	77	683	81	668	79	653	78
		Parkway	T3	953	1141	1499	558	163	581	61	588	52	588	52	581	51	593	52	587	51	581	51	588	52	587	51	604	53	603	53	588	52
		Parkway	T4	953	1141	1499	556	172	581	61	588	52	588	52	581	51	593	52	587	51	581	51	588	52	587	51	604	53	603	53	588	52
		Cherrywood	T15	750	840	1245	549	218	591	79	595	71	596	71	590	70	598	71	589	70	601	72	593	71	593	71	605	72	602	72	594	71
		Cherrywood	T16	750	840	1245	552	218	594	79	598	71	599	71	593	71	601	72	592	70	604	72	595	71	596	71	608	72	605	72	597	71
		Cherrywood	T14	750	840	1245	490	219	537	72	539	64	538	64	537	64	540	64	544	65	525	63	541	64	539	64	548	65	550	66	540	64
		Cherrywood	T17	1122	1315	1362	484	214	529	47	531	40	530	40	529	40	533	40	536	41	517	39	533	41	532	40	541	41	543	41	532	40

System Impact Assessment Addendum Greenfield South GS – Appendix C

Table C-5

Scenario 1.3 Peak Load - Greenfield South on K23C, Cooksville solid Single Contingencies

Monitored Element	Continuous Rating (CR)			Long Term Emergency Rating (LTE)			Limited Time Rating (LTR)			Pre-contingency				Loss of R1K		Loss of R13K + Richview H2 bus (SC21)		Loss of R2K + Richview A1 bus (SC22)		Loss of R15K		Loss of R24C		Loss of K21C		Loss of K23C			
	MVA	MVA	MVA	MVA	MVA	MVA	MVA	%CR	MVA	%LTE	MVA	%LTE	MVA	%LTE	MVA	%LTE	MVA	%LTE	MVA	%LTE	MVA	%LTE	MVA	%LTE	MVA	%LTE	MVA	%LTE	
Richview-Manby-Cooksville Area 230 kV Circuits	R1K	Richview TS	Manby E TS	482	661	802	200	-75	214	44	0	0	366	55	236	36	240	36	257	39	192	29	250	38					
	R13K	Richview TS	Manby E TS	482	661	802	198	-74	212	44	355	54	0	0	233	35	238	36	255	39	190	29	247	37					
	R2K	Richview TS	Manby W TS	482	661	802	332	-55	336	70	354	54	350	53	0	0	571	86	372	56	370	56	426	64					
	R15K	Richview TS	Manby W TS	482	661	802	334	-55	338	70	356	54	352	53	577	87	0	0	374	57	372	56	428	65					
	R24C	Richview TS	Greenfield S	727	969	1239	167	4	167	23	198	20	200	21	211	22	208	21	0	0	156	16	267	28					
		Greenfield S	Applewood Jct	727	969	1201	166	4	166	23	198	20	200	21	210	22	207	21	0	0	156	16	266	27					
		Applewood Jct	Cooksville TS	561	690	806	166	4	166	30	198	29	200	29	210	30	207	30	0	0	155	23	265	38					
	K21C	Manby W TS	Applewood Jct	561	590	806	-46	100	110	20	89	15	134	23	146	25	171	29	104	18	0	0	187	32					
		Applewood Jct	Cooksville	648	648	898	-46	103	112	17	91	14	136	21	147	23	172	27	106	16	0	0	188	29					
	K23C	Manby E TS	Greenfield S	590	590	1010	-40	89	97	16	154	26	122	21	110	19	92	16	108	18	162	27	0	0					
	Greenfield S	Applewood Jct	590	590	1010	282	59	288	49	231	39	226	38	359	61	345	59	381	65	287	49	0	0						
	Applewood Jct	Cooksville TS	561	590	806	282	57	287	51	231	39	226	38	358	61	345	58	380	64	286	49	0	0						
B15C	Cooksville TS	Oakville TS	561	744	898	133	44	140	25	140	19	140	19	140	19	140	19	140	19	140	19	140	19	140	19				
B16C	Cooksville TS	Oakville TS	561	744	898	134	51	143	26	143	19	144	19	144	19	143	19	143	19	144	19	144	19	144	19				
500/230 kV Autotransformers	Trafalgar	T15		939	1155	1499	706	217	739	79	739	64	745	64	745	65	739	64	740	64	739	64	750	65					
	Trafalgar	T14		837	1019	1244	697	219	731	87	731	72	736	72	737	72	731	72	731	72	731	72	742	73					
	Claireville	T13		750	840	1245	678	202	708	94	711	85	717	85	710	85	700	83	715	85	711	85	738	88					
	Claireville	T14		750	840	1245	687	223	722	96	725	86	732	87	726	86	715	85	729	87	725	86	753	90					
	Claireville	T15		750	840	1245	662	205	693	92	689	82	699	83	709	84	704	84	685	82	689	82	718	85					
	Claireville	T16		750	840	1245	615	189	644	86	641	76	650	77	659	78	654	78	637	76	641	76	667	79					
	Parkway	T3		953	1141	1499	558	163	581	61	581	51	587	51	588	52	582	51	581	51	581	51	597	52					
	Parkway	T4		953	1141	1499	556	172	581	61	581	51	587	51	588	52	582	51	581	51	581	51	597	52					
	Cherrywood	T15		750	840	1245	549	218	591	79	590	70	593	71	595	71	593	71	589	70	590	70	600	71					
	Cherrywood	T16		750	840	1245	552	218	593	79	593	71	596	71	598	71	596	71	592	70	593	71	603	72					
Cherrywood	T14		750	840	1245	490	219	537	72	537	64	539	64	538	64	535	64	538	64	537	64	547	65						
Cherrywood	T17		1122	1315	1362	484	214	529	47	530	40	531	40	531	40	528	40	530	40	529	40	539	41						

System Impact Assessment Addendum Greenfield South GS – Appendix C

Table C-6

Scenario 1.3 Peak Load - Greenfield South on K23C, Cooksville solid Double Contingencies

Monitored Element				Continuous Rating (CR)		Pre-contingency				Loss of R1K + R2K + Richview A1 bus (SC22)		Loss of R13K + R15K + Richview H2 bus (SC21)		Loss of K21C + K23C		Loss of Manby SC21+ T3+ T13+ T1+ R2K + Richview A1 bus (SC22) [Manby W A1L2 B/F]		R1K out + loss of R13K		R2K out + loss of R15K		K21C out + loss of R2K (similar for loss of R15K)		K23C out + loss of R13K (similar for loss of R1K)		R2K out + loss of R24C (similar with R15K out)		R13K out + loss of R24C (similar with R1K out)		R2K out + loss of K23C (similar with R15K out)		
				MVA	MVA	MVA	MW	MVA _r	MVA	%CR	MVA	%LTE	MVA	%LTE	MVA	%LTE	MVA	%LTE	MVA	%LTE	MVA	%LTE	MVA	%LTE	MVA	%LTE	MVA	%LTE	MVA	%LTE	MVA	%LTE
Richview- Manby- Cooksville Area	R1K	Richview TS	Manby E TS	482	661	802	200	-75	214	44	0	0	410	62	248	38	230	35	0	0	366	55	192	29	484	73	297	45	459.9	70	245	37
	R13K	Richview TS	Manby E TS	482	661	802	198	-74	212	44	395	60	0	0	246	37	228	34	0	0	363	55	190	29	0	0	294	44	0	0	243	37
	R2K	Richview TS	Manby W TS	482	661	802	332	-55	336	70	0	0	603	91	369	56	0	0	441	67	0	0	0	0	426	64	0	0	400	61	0	0
	R15K	Richview TS	Manby W TS	482	661	802	334	-55	338	70	611	92	0	0	371	56	577	87	443	67	0	0	722	109	428	65	653	99	403	61	762	115
	R24C	Richview TS	Greenfield S	727	969	1239	167	4	167	23	248	26	246	25	452	47	231	24	369	38	385	40	155	16	261	27	0	0	0	0	373	39
		Greenfield S	Applewood Jct	727	969	1201	166	4	166	23	247	26	246	25	445	46	230	24	370	38	385	40	154	16	261	27	0	0	0	0	370	38
230 kV Circuits		Applewood Jct	Cooksville TS	561	690	806	166	4	166	30	247	36	246	36	443	64	229	33	371	54	385	56	154	22	261	38	0	0	369	53		
	K21C	Manby W TS	Applewood Jct	561	590	806	-46	100	110	20	112	19	160	27	0	0	209	35	172	29	605	102	0	0	218	37	72	12	146	25	83	14
		Applewood Jct	Cooksville	648	648	898	-46	103	112	17	113	17	161	25	0	0	208	32	172	27	603	93	0	0	219	34	73	11	148	23	84	13
	K23C	Manby E TS	Greenfield S	590	590	1010	-40	89	97	16	135	23	85	14	0	0	184	31	496	84	264	45	143	24	0	0	198	34	48	8	0	0
		Greenfield S	Applewood Jct	590	590	1010	282	59	288	49	298	51	279	47	0	0	409	69	244	41	584	99	290	49	0	0	489	83	318	54	0	0
		Applewood Jct	Cooksville TS	561	590	806	282	57	287	51	298	50	278	47	0	0	407	69	244	41	584	99	289	49	0	0	488	83	317	54	0	0
B15C	Cooksville TS	Oakville TS	561	744	898	133	44	140	25	140	19	141	19	140	19	140	19	140	19	140	19	140	19	141	19	140	19	140	19	140	19	
B16C	Cooksville TS	Oakville TS	561	744	898	134	51	143	26	144	19	144	19	145	19	145	19	144	19	144	19	144	19	145	19	144	19	144	19	144	19	
	Trafalgar	T15	939	1155	1499	706	217	739	79	745	65	745	65	749	65	750	65	746	65	737	64	746	65	756	65	746	65	745	65	757	66	
	Trafalgar	T14	837	1019	1244	697	219	731	87	737	72	737	72	741	73	742	73	738	72	729	72	738	72	748	73	738	72	737	72	748	73	
500/230 kV Autotransformers	Claireville	T13	750	840	1245	678	202	708	94	713	85	709	84	724	86	718	85	732	87	655	78	723	86	745	89	718	85	726	86	742	88	
	Claireville	T14	750	840	1245	687	223	722	96	729	87	724	86	739	88	734	87	747	89	670	80	739	88	760	90	734	87	741	88	758	90	
	Claireville	T15	750	840	1245	662	205	693	92	706	84	710	85	734	87	715	85	684	81	745	89	695	83	728	87	701	83	690	82	734	87	
	Claireville	T16	750	840	1245	615	189	644	86	656	78	660	79	682	81	665	79	635	76	692	82	646	77	676	80	652	78	641	76	682	81	
	Parkway	T3	953	1141	1499	558	163	581	61	588	52	588	52	597	52	593	52	587	51	581	51	588	52	603	53	588	52	587	51	604	53	
	Parkway	T4	953	1141	1499	556	172	581	61	588	52	588	52	597	52	593	52	587	51	581	51	588	52	603	53	588	52	587	51	604	53	
	Cherrywood	T15	750	840	1245	549	218	591	79	595	71	596	71	604	72	598	71	590	70	601	72	593	71	604	72	594	71	591	70	605	72	
	Cherrywood	T16	750	840	1245	552	218	593	79	598	71	599	71	606	72	601	72	593	71	604	72	595	71	606	72	597	71	594	71	608	72	
	Cherrywood	T14	750	840	1245	490	219	537	72	539	64	538	64	543	65	541	64	542	65	525	63	541	64	549	65	540	64	541	64	549	65	
	Cherrywood	T17	1122	1315	1362	484	214	529	47	531	40	530	40	535	41	533	41	535	41	517	39	533	41	541	41	532	40	533	41	541	41	

-End of Section-

-intentionally left blank-

Appendix D

Voltage Analysis Results

System Impact Assessment Addendum Greenfield South GS – Appendix D

Table D-1

Scenario 1.1 Peak Load - Greenfield South out of service, Cooksville solid
Single Contingencies

Monitored Element	Pre-contingency Voltage kV	Loss of R1K				Loss of R13K + Richview H2 bus (SC21)				Loss of R2K + Richview A1 bus (SC22)				Loss of R15K				Loss of R24C				Loss of K21C				Loss of K23C			
		pre-ULTC		post-ULTC		pre-ULTC		post-ULTC		pre-ULTC		post-ULTC		pre-ULTC		post-ULTC		pre-ULTC		post-ULTC		pre-ULTC		post-ULTC		pre-ULTC		post-ULTC	
		kV	%VD	kV	%VD	kV	%VD	kV	%VD	kV	%VD	kV	%VD	kV	%VD	kV	%VD	kV	%VD	kV	%VD	kV	%VD	kV	%VD	kV	%VD	kV	%VD
Richview AH1 230 kV	244.4	244.3	0.0	244.4	0.0	241.3	1.3	240.7	1.5	239.1	2.2	238.3	2.5	243.9	0.2	243.6	0.3	244.3	0.0	244.2	0.1	244.9	-0.2	244.9	-0.2	244.0	0.2	244.0	0.2
Richview AH2 230 kV	244.4	244.3	0.0	244.3	0.0	239.7	1.9	239.1	2.2	241.1	1.4	240.3	1.7	244.0	0.2	243.7	0.3	244.5	0.0	244.5	0.0	243.6	0.3	243.5	0.4	244.7	-0.1	244.7	-0.1
Greenfield 230 kV	244.1	244.1	0.0	244.2	0.0	240.0	1.7	239.3	2.0	240.3	1.6	239.2	2.0	243.7	0.2	243.3	0.3	0.0	0.0	0.0	0.0	242.5	0.7	242.3	0.7	243.6	0.2	243.6	0.2
Greenfield G1 16.5 kV	16.6	16.6	0.0	16.6	0.0	16.4	1.2	16.3	1.8	16.4	1.2	16.3	1.8	16.6	0.0	16.6	0.0	0.0	0.0	0.0	0.0	16.5	0.6	16.5	0.6	16.6	0.0	16.6	0.0
Greenfield G2 13.8 kV	13.9	13.9	0.0	13.9	0.0	13.6	2.2	13.6	2.2	13.6	2.2	13.6	2.2	13.8	0.7	13.8	0.7	0.0	0.0	0.0	0.0	13.8	0.7	13.8	0.7	13.8	0.7	13.8	0.7
Manby E 230 kV	245.1	245.4	-0.1	245.5	-0.2	241.2	1.6	240.4	1.9	241.5	1.5	240.5	1.9	244.7	0.2	244.3	0.3	245.1	0.0	245.0	0.0	243.9	0.5	243.7	0.6	245.9	-0.3	245.9	-0.3
Manby E 118 kV	124.2	124.4	-0.2	124.4	-0.2	122.2	1.6	121.6	2.1	122.4	1.4	121.6	2.1	124.0	0.2	123.8	0.3	124.2	0.0	124.2	0.0	123.6	0.5	123.4	0.6	124.6	-0.3	124.7	-0.4
Manby W 230 kV	244.7	244.7	0.0	244.7	0.0	241.2	1.4	240.5	1.7	240.1	1.9	238.9	2.4	244.1	0.2	243.6	0.4	244.5	0.1	244.5	0.1	245.9	-0.5	245.9	-0.5	244.0	0.3	243.9	0.3
Manby W 118 kV	124.2	124.2	0.0	124.2	0.0	122.4	1.4	121.9	1.9	121.9	1.9	121.0	2.6	123.9	0.2	123.6	0.5	124.1	0.1	124.1	0.1	124.8	-0.5	124.9	-0.6	123.9	0.2	123.8	0.3
Cooksville E 230 kV	244.0	244.1	0.0	244.1	0.0	240.3	1.5	239.5	1.8	239.9	1.7	238.7	2.2	243.5	0.2	243.1	0.4	243.8	0.1	243.8	0.1	241.9	0.9	241.7	0.9	243.1	0.4	243.0	0.4
Cooksville W 230 kV	244.0	244.1	0.0	244.1	0.0	240.3	1.5	239.5	1.8	239.9	1.7	238.7	2.2	243.5	0.2	243.1	0.4	243.8	0.1	243.8	0.1	241.9	0.9	241.7	0.9	243.1	0.4	243.0	0.4
Lorne Park B15C	243.5	243.6	0.0	243.6	0.0	239.8	1.5	239.0	1.8	239.4	1.7	238.2	2.2	243.0	0.2	242.6	0.4	243.3	0.1	243.3	0.1	241.4	0.9	241.2	0.9	242.6	0.4	242.5	0.4
Lorne Park B16C	243.5	243.5	0.0	243.6	0.0	239.7	1.6	238.9	1.9	239.4	1.7	238.1	2.2	243.0	0.2	242.5	0.4	243.3	0.1	243.2	0.1	241.3	0.9	241.1	1.0	242.6	0.4	242.5	0.4
Lorne Park B 27.6 kV	28.1	28.1	0.0	28.1	0.0	27.6	1.8	27.5	2.1	27.6	1.8	27.4	2.5	28.0	0.4	27.9	0.7	28.0	0.4	28.0	0.4	27.8	1.1	27.8	1.1	27.9	0.7	27.9	0.7
Lorne Park J 27.6 kV	28.5	28.5	0.0	28.5	0.0	28.1	1.4	28.0	1.8	28.1	1.4	27.9	2.1	28.5	0.0	28.4	0.4	28.5	0.0	28.5	0.0	28.3	0.7	28.2	1.1	28.4	0.4	28.4	0.4
Ford B15C 230 kV	242.8	242.9	0.0	242.9	0.0	239.1	1.5	238.2	1.9	238.7	1.7	237.5	2.2	242.3	0.2	241.9	0.4	242.6	0.1	242.6	0.1	240.7	0.9	240.5	0.9	241.9	0.4	241.8	0.4
Ford B16C 230 kV	242.6	242.7	0.0	242.7	0.0	238.9	1.5	238.0	1.9	238.5	1.7	237.3	2.2	242.2	0.2	241.7	0.4	242.5	0.0	242.4	0.1	240.5	0.9	240.3	0.9	241.7	0.4	241.6	0.4
Ford AB 27.6 kV	29.5	29.6	-0.3	29.6	-0.3	29.1	1.4	29.3	0.7	29.0	1.7	29.2	1.0	29.5	0.0	29.4	0.3	29.5	0.0	29.5	0.0	29.3	0.7	29.2	1.0	29.4	0.3	29.4	0.3
Oakville B15C	242.8	242.9	0.0	242.9	0.0	239.0	1.6	238.2	1.9	238.7	1.7	237.4	2.2	242.3	0.2	241.8	0.4	242.6	0.1	242.6	0.1	240.7	0.9	240.4	1.0	241.9	0.4	241.8	0.4
Oakville B16C	242.6	242.7	0.0	242.7	0.0	238.9	1.5	238.0	1.9	238.5	1.7	237.2	2.2	242.1	0.2	241.7	0.4	242.4	0.1	242.4	0.1	240.5	0.9	240.3	0.9	241.7	0.4	241.6	0.4
Oakville E 27.6 kV	28.5	28.5	0.0	28.5	0.0	28.1	1.4	27.9	2.1	28.0	1.8	27.8	2.5	28.5	0.0	28.4	0.4	28.5	0.0	28.5	0.0	28.3	0.7	28.2	1.1	28.4	0.4	28.4	0.4
Oakville Z 27.6 kV	27.2	27.2	0.0	27.2	0.0	26.8	1.5	26.5	2.6	26.7	1.8	26.4	2.9	27.1	0.4	27.0	0.7	27.2	0.0	27.1	0.4	26.9	1.1	26.9	1.1	27.1	0.4	27.0	0.7

System Impact Assessment Addendum Greenfield South GS – Appendix D

Table D-2

Scenario 1.1 Peak Load - Greenfield South out of service, Cooksville solid Double Contingencies

Monitored Element	Pre-contingency Voltage kV	Loss of R1K + R2K + Richview A1 bus (SC22)				Loss of R13K + R15K + Richview H2 bus (SC21)				Loss of K21C + K23C				Loss of Manby SC21+ T3+ T13+ T1+ R2K + Richview A1 bus (SC22) [Manby W A1L2 B/F]				R1K out + loss of R13K				R2K out + loss of R15K				K21C out + loss of R2K (similar for loss of R15K)				K23C out + loss of R13K (similar for loss of R1K)				R2K out + loss of R24C (similar with R15K out)				R13K out + loss of R24C (similar with R1K out)				R2K out + loss of K23C (similar with R15K out)			
		pre-ULTC	post-ULTC	pre-ULTC	post-ULTC	pre-ULTC	post-ULTC	pre-ULTC	post-ULTC	pre-ULTC	post-ULTC	pre-ULTC	post-ULTC	pre-ULTC	post-ULTC	pre-ULTC	post-ULTC	pre-ULTC	post-ULTC	pre-ULTC	post-ULTC	pre-ULTC	post-ULTC	pre-ULTC	post-ULTC	pre-ULTC	post-ULTC	pre-ULTC	post-ULTC	pre-ULTC	post-ULTC	pre-ULTC	post-ULTC	pre-ULTC	post-ULTC	pre-ULTC	post-ULTC								
		kV	%VD	kV	%VD	kV	%VD	kV	%VD	kV	%VD	kV	%VD	kV	%VD	kV	%VD	kV	%VD	kV	%VD	kV	%VD	kV	%VD	kV	%VD	kV	%VD	kV	%VD	kV	%VD	kV	%VD	kV	%VD	kV	%VD	kV	%VD				
Richview AH1 230 kV	244.4	244.3	0.0	238.2	2.5	240.9	1.4	240.0	1.8	244.9	-0.2	244.9	-0.2	235.9	3.5	234.7	4.0	241.3	1.3	240.8	1.5	239.1	2.2	238.9	2.3	239.2	2.1	238.3	2.5	241.0	1.4	240.4	1.6	238.9	2.3	238.0	2.6	241.3	1.3	240.6	1.6	238.7	2.3	237.7	2.7
Richview AH2 230 kV	244.4	244.3	0.0	240.1	1.8	239.2	2.1	238.4	2.5	243.6	0.3	243.3	0.5	238.2	2.5	236.9	3.1	239.0	2.2	238.6	2.4	241.8	1.1	241.3	1.3	240.7	1.5	239.9	1.8	239.9	1.8	239.3	2.1	241.2	1.3	240.3	1.7	239.6	2.0	239.0	2.2	241.4	1.2	240.6	1.6
Greenfield 230 kV	244.1	244.1	0.0	239.1	2.0	239.5	1.9	238.3	2.4	239.7	1.8	239.1	2.0	236.2	3.2	234.5	3.9	240.2	1.6	239.6	1.8	241.9	0.9	241.3	1.1	239.6	1.8	238.6	2.3	239.6	1.8	238.9	2.1	0.0	0.0	0.0	0.0	239.4	1.9	238.1	2.5				
Greenfield G1 16.5 kV	16.6	16.6	0.0	16.3	1.8	16.3	1.8	16.3	1.8	16.3	1.8	16.3	1.8	16.1	3.0	16.0	3.6	16.4	1.2	16.3	1.8	16.5	0.6	16.5	0.6	16.3	1.8	16.3	1.8	16.3	1.8	16.3	1.8	0.0	0.0	0.0	0.0	16.3	1.8	16.2	2.4				
Greenfield G2 13.8 kV	13.9	13.9	0.0	13.6	2.2	13.6	2.2	13.5	2.9	13.6	2.2	13.6	2.2	13.4	3.6	13.3	4.3	13.6	2.2	13.6	2.2	13.7	1.4	13.7	1.4	13.6	2.2	13.6	2.2	13.6	2.2	13.6	2.2	0.0	0.0	0.0	0.0	13.6	2.2	13.5	2.9				
Manby E 230 kV	245.1	245.4	-0.1	240.5	1.9	240.6	1.8	239.5	2.3	244.8	0.1	244.6	0.2	238.0	2.9	236.4	3.5	243.7	0.6	242.9	0.9	242.5	1.1	242.0	1.3	241.0	1.7	240.0	2.1	242.3	1.1	241.6	1.4	241.3	1.6	240.2	2.0	241.1	1.6	240.3	2.0	242.7	1.0	241.7	1.4
Manby E 118 kV	124.2	124.4	-0.2	121.6	2.1	121.9	1.9	121.1	2.5	124.1	0.1	123.9	0.2	120.6	2.9	119.5	3.8	123.5	0.6	123.0	1.0	122.9	1.0	122.5	1.4	122.1	1.7	121.4	2.3	122.8	1.1	122.2	1.6	122.3	1.5	121.5	2.2	122.2	1.6	121.5	2.2	122.9	1.0	122.3	1.5
Manby W 230 kV	244.7	244.7	0.0	238.8	2.4	240.5	1.7	239.2	2.2	245.9	-0.5	245.8	-0.4	234.5	4.2	232.3	5.1	241.5	1.3	240.8	1.6	243.1	0.7	242.4	0.9	240.5	1.7	239.1	2.3	240.7	1.6	239.9	2.0	239.7	2.0	238.2	2.7	241.2	1.4	240.4	1.8	238.9	2.4	237.4	3.0
Manby W 118 kV	124.2	124.2	0.0	120.9	2.7	122.0	1.8	121.1	2.5	124.8	-0.5	124.8	-0.5	118.5	4.6	116.5	6.2	122.6	1.3	122.1	1.7	123.4	0.6	122.9	1.0	122.1	1.7	121.1	2.5	122.2	1.6	121.6	2.1	121.6	2.1	120.6	2.9	122.4	1.4	121.8	1.9	121.2	2.4	120.2	3.2
Cooksville E 230 kV	244.0	244.1	0.0	238.7	2.2	239.6	1.8	238.4	2.3	237.8	2.5	237.1	2.8	235.3	3.6	233.3	4.4	241.0	1.2	240.2	1.6	242.1	0.8	241.4	1.1	239.0	2.0	238.0	2.5	239.6	1.8	238.7	2.2	239.4	1.9	237.9	2.5	240.3	1.5	239.5	1.8	238.4	2.3	236.9	2.9
Cooksville W 230 kV	244.0	244.1	0.0	238.7	2.2	239.6	1.8	238.4	2.3	237.8	2.5	237.1	2.8	235.3	3.6	233.3	4.4	241.0	1.2	240.2	1.6	242.1	0.8	241.4	1.1	239.0	2.0	238.0	2.5	239.6	1.8	238.7	2.2	239.4	1.9	237.9	2.5	240.3	1.5	239.5	1.8	238.4	2.3	236.9	2.9
Lorne Park B15C	243.5	243.6	0.0	238.1	2.2	239.1	1.8	237.8	2.3	237.3	2.5	236.5	2.9	234.8	3.6	232.8	4.4	240.5	1.2	239.7	1.6	241.6	0.8	240.9	1.1	238.5	2.1	237.4	2.5	239.1	1.8	238.2	2.2	238.9	1.9	237.4	2.5	239.9	1.5	238.9	1.9	237.9	2.3	236.4	2.9
Lorne Park B16C	243.5	243.5	0.0	238.0	2.3	239.1	1.8	237.8	2.3	237.2	2.6	236.4	2.9	234.7	3.6	232.7	4.4	240.4	1.3	239.6	1.6	241.5	0.8	240.8	1.1	238.5	2.1	237.3	2.5	239.0	1.8	238.1	2.2	238.8	1.9	237.3	2.5	239.8	1.5	238.9	1.9	237.8	2.3	236.3	3.0
Lorne Park B 27.6 kV	28.1	28.1	0.0	27.4	2.5	27.5	2.1	27.3	2.8	27.3	2.8	27.2	3.2	27.0	3.9	27.3	2.8	27.7	1.4	27.6	1.8	27.8	1.1	27.7	1.4	27.5	2.1	27.3	2.8	27.5	2.1	27.4	2.5	27.5	2.1	27.3	2.8	27.6	1.8	27.5	2.1	27.4	2.5	27.4	2.5
Lorne Park J 27.6 kV	28.5	28.5	0.0	27.9	2.1	28.0	1.8	27.8	2.5	27.8	2.5	27.7	2.8	27.5	3.5	27.8	2.5	28.2	1.1	28.1	1.4	28.3	0.7	28.2	1.1	28.0	1.8	27.8	2.5	28.0	1.8	27.9	2.1	28.0	1.8	27.8	2.5	28.1	1.4	28.0	1.8	27.9	2.1	27.9	2.1
Ford B15C 230 kV	242.8	242.9	0.0	237.4	2.2	238.4	1.8	237.1	2.3	236.6	2.6	235.8	2.9	234.1	3.6	232.0	4.4	239.8	1.2	239.0	1.6	240.9	0.8	240.2	1.1	237.9	2.0	236.7	2.5	238.4	1.8	237.5	2.2	238.2	1.9	236.7	2.5	239.2	1.5	238.2	1.9	237.2	2.3	235.6	3.0
Ford B16C 230 kV	242.6	242.7	0.0	237.2	2.2	238.3	1.8	236.9	2.3	236.4	2.6	235.6	2.9	233.9	3.6	231.8	4.5	239.6	1.2	238.8	1.6	240.7	0.8	240.0	1.1	237.7	2.0	236.5	2.5	238.2	1.8	237.3	2.2	238.0	1.9	236.5	2.5	239.0	1.5	238.0	1.9	237.0	2.3	235.4	3.0
Ford AB 27.6 kV	29.5	29.6	-0.3	29.2	1.0	29.0	1.7	29.1	1.4	28.8	2.4	29.3	0.7	28.5	3.4	29.1	1.4	29.2	1.0	29.1	1.4	29.3	0.7	29.2	1.0	28.9	2.0	29.1	1.4	29.0	1.7	29.2	1.0	29.0	1.7	29.1	1.4	29.1	1.4	29.3	0.7	28.9	2.0	29.2	1.0
Oakville B15C	242.8	242.9	0.0	237.3	2.3	238.4	1.8	237.1	2.3	236.6	2.6	235.8	2.9	234.0	3.6	232.0	4.4	239.7	1.3	238.9	1.6	240.8	0.8	240.1	1.1	237.8	2.1	236.6	2.6	238.3	1.9	237.4	2.2	238.1	1.9	236.6	2.6	239.1	1.5	238.2	1.9	237.1	2.3	235.6	3.0
Oakville B16C	242.6	242.7	0.0	237.2	2.2	238.2	1.8	236.9	2.3	236.4	2.6	235.5	2.9	233.9	3.6	231.8	4.5	239.5	1.3	238.8	1.6	240.6	0.8	239.9	1.1	237.6	2.1	236.5	2.5	238.2	1.8	237.3	2.2	238.0	1.9	236.4	2.6	238.9	1.5	238.0	1.9	237.0	2.3	235.4	3.0
Oakville E 27.6 kV	28.5	28.5	0.0	27.8	2.5	28.0	1.8	27.7	2.8	27.8	2.5	27.9	2.1	27.5	3.5	27.7	2.8	28.2	1.1	28.0	1.8	28.3	0.7	28.1	1.4	27.9	2.1	27.7	2.8	28.0	1.8	27.8	2.5	28.0	1.8	27.7	2.8	28.1	1.4	27.9	2.1	27.8	2.5	27.9	2.1
Oakville Z 27.6 kV	27.2	27.2	0.0	26.4	2.9	26.7	1.8	26.4	2.9	26.5	2.6	26.6	2.2	26.2	3.7	26.4	2.9	26.8	1.5	26.7	1.8	27.0	0.7	26.8	1.5	26.6	2.2	26.3	3.3	26.7	1.8	26.4	2.9	26.7	1.8	26.3	3.3	26.8	1.5	26.5	2.6	26.5	2.6	26.5	2.6

System Impact Assessment Addendum Greenfield South GS – Appendix D

Table D-3

Scenario 1.2

Peak Load - Greenfield South on R24C, Cooksville solid
Single Contingencies

Monitored Element	Pre-contingency Voltage kV	Loss of R1K				Loss of R13K + Richview H2 bus (SC21)				Loss of R2K + Richview A1 bus (SC22)				Loss of R15K				Loss of R24C				Loss of K21C				Loss of K23C			
		pre-ULTC kV	%VD	post-ULTC kV	%VD	pre-ULTC kV	%VD	post-ULTC kV	%VD	pre-ULTC kV	%VD	post-ULTC kV	%VD	pre-ULTC kV	%VD	post-ULTC kV	%VD	pre-ULTC kV	%VD	post-ULTC kV	%VD	pre-ULTC kV	%VD	post-ULTC kV	%VD	pre-ULTC kV	%VD	post-ULTC kV	%VD
Richview AH1 230 kV	245.0	244.9	0.0	245.0	0.0	242.2	1.1	241.7	1.3	240.0	2.0	239.3	2.3	244.5	0.2	244.3	0.3	243.9	0.4	243.7	0.5	245.5	-0.2	245.5	-0.2	244.7	0.1	244.6	0.2
Richview AH2 230 kV	245.0	244.9	0.0	244.9	0.0	240.6	1.8	240.2	2.0	242.1	1.2	241.4	1.5	244.7	0.1	244.5	0.2	244.1	0.4	243.9	0.4	244.4	0.2	244.3	0.3	245.3	-0.1	245.3	-0.1
Greenfield 230 kV	244.7	244.8	0.0	244.8	0.0	241.3	1.4	240.7	1.6	241.5	1.3	240.7	1.6	244.4	0.1	244.1	0.2	0.0	0.0	0.0	0.0	243.4	0.5	243.3	0.6	244.3	0.2	244.3	0.2
Greenfield G1 16.5 kV	16.7	16.7	0.0	16.7	0.0	16.7	0.0	16.7	0.0	16.7	0.0	16.7	0.0	16.7	0.0	16.7	0.0	0.0	0.0	0.0	0.0	16.7	0.0	16.7	0.0	16.7	0.0	16.7	0.0
Greenfield G2 13.8 kV	13.9	13.9	0.0	13.9	0.0	13.9	0.0	13.9	0.0	13.9	0.0	13.9	0.0	13.9	0.0	13.9	0.0	0.0	0.0	0.0	0.0	13.9	0.0	13.9	0.0	13.9	0.0	13.9	0.0
Manby E 230 kV	245.8	246.1	-0.1	246.1	-0.1	242.2	1.5	241.6	1.7	242.5	1.3	241.7	1.7	245.4	0.2	245.1	0.3	244.7	0.4	244.4	0.6	244.7	0.4	244.6	0.5	246.6	-0.3	246.6	-0.3
Manby E 118 kV	124.5	124.7	-0.2	124.8	-0.2	122.8	1.4	122.3	1.8	122.9	1.3	122.3	1.8	124.4	0.1	124.2	0.2	124.0	0.4	123.8	0.6	124.0	0.4	123.9	0.5	125.0	-0.4	125.0	-0.4
Manby W 230 kV	245.3	245.3	0.0	245.3	0.0	242.3	1.2	241.6	1.5	241.2	1.7	240.1	2.1	244.8	0.2	244.4	0.4	244.1	0.5	243.9	0.6	246.5	-0.5	246.5	-0.5	244.7	0.2	244.7	0.2
Manby W 118 kV	124.5	124.5	0.0	124.6	-0.1	123.0	1.2	122.5	1.6	122.4	1.7	121.7	2.2	124.3	0.2	124.1	0.3	123.9	0.5	123.7	0.6	125.1	-0.5	125.2	-0.6	124.2	0.2	124.2	0.2
Cooksville E 230 kV	244.7	244.7	0.0	244.8	0.0	241.4	1.3	240.8	1.6	241.0	1.5	240.1	1.9	244.3	0.2	243.9	0.3	243.5	0.5	243.2	0.6	242.8	0.8	242.7	0.8	243.8	0.4	243.8	0.4
Cooksville W 230 kV	244.7	244.7	0.0	244.8	0.0	241.4	1.3	240.8	1.6	241.0	1.5	240.1	1.9	244.3	0.2	243.9	0.3	243.5	0.5	243.2	0.6	242.8	0.8	242.7	0.8	243.8	0.4	243.8	0.4
Lorne Park B15C	244.2	244.2	0.0	244.3	0.0	240.9	1.4	240.2	1.6	240.5	1.5	239.6	1.9	243.8	0.2	243.4	0.3	243.0	0.5	242.7	0.6	242.3	0.8	242.2	0.8	243.4	0.3	243.3	0.4
Lorne Park B16C	244.1	244.2	0.0	244.2	0.0	240.8	1.4	240.2	1.6	240.5	1.5	239.5	1.9	243.7	0.2	243.4	0.3	242.9	0.5	242.6	0.6	242.3	0.7	242.1	0.8	243.3	0.3	243.2	0.4
Lorne Park B 27.6 kV	28.1	28.1	0.0	28.1	0.0	27.8	1.1	27.6	1.8	27.7	1.4	27.5	2.1	28.1	0.0	28.0	0.4	28.0	0.4	27.9	0.7	27.9	0.7	27.9	0.7	28.0	0.4	28.0	0.4
Lorne Park J 27.6 kV	28.6	28.6	0.0	28.6	0.0	28.2	1.4	28.1	1.7	28.2	1.4	28.0	2.1	28.6	0.0	28.5	0.3	28.5	0.3	28.4	0.7	28.4	0.7	28.4	0.7	28.5	0.3	28.5	0.3
Ford B15C 230 kV	243.5	243.6	0.0	243.6	0.0	240.2	1.4	239.5	1.6	239.9	1.5	238.8	1.9	243.1	0.2	242.7	0.3	242.3	0.5	242.0	0.6	241.6	0.8	241.5	0.8	242.7	0.3	242.6	0.4
Ford B16C 230 kV	243.3	243.4	0.0	243.4	0.0	240.0	1.4	239.3	1.6	239.7	1.5	238.7	1.9	242.9	0.2	242.5	0.3	242.1	0.5	241.8	0.6	241.5	0.7	241.3	0.8	242.5	0.3	242.4	0.4
Ford AB 27.6 kV	29.3	29.3	0.0	29.3	0.0	28.9	1.4	29.1	0.7	28.9	1.4	29.0	1.0	29.3	0.0	29.2	0.3	29.2	0.3	29.1	0.7	29.1	0.7	29.1	0.7	29.2	0.3	29.2	0.3
Oakville B15C	243.4	243.5	0.0	243.5	0.0	240.2	1.3	239.5	1.6	239.8	1.5	238.8	1.9	243.0	0.2	242.7	0.3	242.2	0.5	241.9	0.6	241.6	0.7	241.4	0.8	242.6	0.3	242.5	0.4
Oakville B16C	243.3	243.3	0.0	243.4	0.0	240.0	1.4	239.3	1.6	239.7	1.5	238.6	1.9	242.9	0.2	242.5	0.3	242.1	0.5	241.8	0.6	241.4	0.8	241.2	0.9	242.4	0.4	242.4	0.4
Oakville E 27.6 kV	28.6	28.6	0.0	28.6	0.0	28.2	1.4	28.1	1.7	28.2	1.4	28.0	2.1	28.6	0.0	28.5	0.3	28.5	0.3	28.4	0.7	28.4	0.7	28.3	1.0	28.5	0.3	28.5	0.3
Oakville Z 27.6 kV	27.3	27.3	0.0	27.3	0.0	26.9	1.5	26.7	2.2	26.9	1.5	26.6	2.6	27.2	0.4	27.2	0.4	27.1	0.7	27.1	0.7	27.1	0.7	27.0	1.1	27.2	0.4	27.1	0.7

System Impact Assessment Addendum Greenfield South GS – Appendix D

Table D-4

Scenario 1.2 Peak Load - Greenfield South on R24C, Cookeville solid Double Contingencies

Monitored Element	Pre-contingency Voltage kV	Loss of R1K + R2K + Richview A1 bus (SC22)				Loss of R13K + R15K + Richview H2 bus (SC21)				Loss of K21C + K23C				Loss of Manby SC21+ T3+ T13+ T1+ R2K + Richview A1 bus (SC22) [Manby W A1L2 B/F]				R1K out + loss of R13K				R2K out + loss of R15K				K21C out + loss of R2K (similar for loss of R15K)				K23C out + loss of R13K (similar for loss of R1K)				R2K out + loss of R24C (similar with R15K out)				R13K out + loss of R24C (similar with R1K out)				R2K out + loss of K23C (similar with R15K out)			
		pre-ULTC	post-ULTC	pre-ULTC	post-ULTC	pre-ULTC	post-ULTC	pre-ULTC	post-ULTC	pre-ULTC	post-ULTC	pre-ULTC	post-ULTC	pre-ULTC	post-ULTC	pre-ULTC	post-ULTC	pre-ULTC	post-ULTC	pre-ULTC	post-ULTC	pre-ULTC	post-ULTC	pre-ULTC	post-ULTC	pre-ULTC	post-ULTC	pre-ULTC	post-ULTC	pre-ULTC	post-ULTC	pre-ULTC	post-ULTC	pre-ULTC	post-ULTC										
		kV	%VD	kV	%VD	kV	%VD	kV	%VD	kV	%VD	kV	%VD	kV	%VD	kV	%VD	kV	%VD	kV	%VD	kV	%VD	kV	%VD	kV	%VD	kV	%VD	kV	%VD	kV	%VD	kV	%VD										
Richview AH1 230 kV	245.0	240.0	2.0	239.3	2.3	241.8	1.3	241.1	1.6	245.7	-0.3	245.7	-0.3	237.0	3.3	235.9	3.7	242.2	1.1	241.9	1.3	239.8	2.1	239.7	2.2	239.9	2.1	239.1	2.4	242.0	1.2	241.5	1.4	238.6	2.6	237.6	3.0	240.9	1.7	240.1	2.0	239.7	2.2	238.9	2.5
Richview AH2 230 kV	245.0	241.9	1.3	241.3	1.5	240.3	1.9	239.5	2.2	244.7	0.1	244.6	0.2	239.4	2.3	238.3	2.7	239.9	2.1	239.6	2.2	242.9	0.9	242.6	1.0	241.8	1.3	241.2	1.6	240.8	1.7	240.4	1.9	240.8	1.7	239.9	2.1	239.2	2.4	238.6	2.6	242.5	1.0	241.8	1.3
Greenfield 230 kV	244.7	241.5	1.3	240.7	1.6	240.8	1.6	239.9	2.0	241.4	1.3	241.1	1.5	238.0	2.7	236.6	3.3	241.5	1.3	241.1	1.5	243.2	0.6	242.9	0.7	241.0	1.5	240.3	1.8	241.0	1.5	240.4	1.8	0.0	0.0	0.0	0.0	240.9	1.7	240.1	2.0	239.7	2.2	238.9	2.5
Greenfield G1 16.5 kV	16.7	16.7	0.0	16.7	0.0	16.7	0.0	16.7	0.0	16.7	0.0	16.7	0.0	16.7	0.0	16.7	0.0	16.7	0.0	16.7	0.0	16.7	0.0	16.7	0.0	16.7	0.0	16.7	0.0	16.7	0.0	16.7	0.0	16.7	0.0	16.7	0.0	16.7	0.0	16.7	0.0	16.7	0.0	16.7	0.0
Greenfield G2 13.8 kV	13.9	13.9	0.0	13.9	0.0	13.9	0.0	13.9	0.0	13.9	0.0	13.9	0.0	13.9	0.0	13.9	0.0	13.9	0.0	13.9	0.0	13.9	0.0	13.9	0.0	13.9	0.0	13.9	0.0	13.9	0.0	13.9	0.0	13.9	0.0	13.9	0.0	13.9	0.0	13.9	0.0	13.9	0.0	13.9	0.0
Manby E 230 kV	245.8	242.8	1.2	241.8	1.6	241.8	1.6	240.8	2.0	245.9	0.0	245.8	0.0	239.4	2.6	237.9	3.2	245.0	0.3	244.4	0.6	243.8	0.8	243.5	0.9	242.2	1.5	241.4	1.8	243.3	1.0	242.7	1.3	241.0	2.0	239.8	2.4	240.8	2.0	239.8	2.4	243.7	0.9	242.9	1.2
Manby E 118 kV	124.5	123.0	1.2	122.4	1.7	122.5	1.6	121.8	2.2	124.6	-0.1	124.6	-0.1	121.3	2.6	120.3	3.4	124.2	0.2	123.8	0.6	123.5	0.8	123.3	1.0	122.7	1.4	122.2	1.8	123.3	1.0	122.8	1.4	122.1	1.9	121.3	2.6	122.0	2.0	121.3	2.6	123.5	0.8	123.0	1.2
Manby W 230 kV	245.3	241.2	1.7	240.1	2.1	241.7	1.5	240.5	2.0	246.6	-0.5	246.7	-0.6	235.9	3.8	234.0	4.6	242.7	1.1	242.2	1.3	244.5	0.3	244.1	0.5	241.3	1.6	239.9	2.2	241.9	1.4	241.2	1.7	239.3	2.4	237.8	3.1	240.9	1.8	239.9	2.2	240.2	2.1	238.9	2.6
Manby W 118 kV	124.5	122.4	1.7	121.7	2.2	122.7	1.4	121.9	2.1	125.2	-0.6	125.3	-0.6	119.2	4.3	117.4	5.7	123.2	1.0	122.8	1.4	124.1	0.3	123.9	0.5	122.5	1.6	121.6	2.3	122.8	1.4	122.3	1.8	121.5	2.4	122.3	1.8	121.5	2.4	121.9	2.1	121.0	2.8		
Cookeville E 230 kV	244.7	241.1	1.5	240.1	1.9	240.9	1.6	239.8	2.0	239.5	2.1	239.0	2.3	236.8	3.2	235.1	3.9	242.2	1.0	241.7	1.2	243.4	0.5	243.0	0.7	240.4	1.8	239.6	2.1	240.8	1.6	240.1	1.9	239.0	2.3	237.6	2.9	240.0	1.9	238.9	2.4	239.7	2.0	238.5	2.5
Cookeville W 230 kV	244.7	241.1	1.5	240.1	1.9	240.9	1.6	239.8	2.0	239.5	2.1	239.0	2.3	236.8	3.2	235.1	3.9	242.2	1.0	241.7	1.2	243.4	0.5	243.0	0.7	240.4	1.8	239.6	2.1	240.8	1.6	240.1	1.9	239.0	2.3	237.6	2.9	240.0	1.9	238.9	2.4	239.7	2.0	238.5	2.5
Lorne Park B15C	244.2	240.6	1.5	239.5	1.9	240.4	1.6	239.3	2.0	239.0	2.1	238.5	2.3	236.3	3.2	234.5	4.0	241.7	1.0	241.2	1.2	242.9	0.5	242.5	0.7	239.9	1.8	239.1	2.1	240.3	1.6	239.6	1.9	238.5	2.3	237.0	2.9	239.5	1.9	238.4	2.4	239.2	2.0	238.0	2.5
Lorne Park B16C	244.1	240.5	1.5	239.5	1.9	240.3	1.6	239.2	2.0	238.9	2.1	238.4	2.3	236.2	3.2	234.4	4.0	241.6	1.0	241.1	1.2	242.8	0.5	242.5	0.7	239.8	1.8	239.0	2.1	240.2	1.6	239.5	1.9	238.5	2.3	236.9	2.9	239.5	1.9	238.3	2.4	239.2	2.0	237.9	2.5
Lorne Park B 27.6 kV	28.1	27.7	1.4	27.5	2.1	27.7	1.4	27.5	2.1	27.5	2.1	27.4	2.5	27.2	3.2	27.2	3.2	27.9	0.7	27.8	1.1	28.0	0.4	27.9	0.7	27.7	1.4	27.5	2.1	27.7	1.4	27.5	2.1	27.5	2.1	27.2	3.2	27.6	1.8	27.4	2.5	27.6	1.8	27.3	2.8
Lorne Park J 27.6 kV	28.6	28.2	1.4	28.0	2.1	28.2	1.4	28.0	2.1	28.0	2.1	27.9	2.4	27.7	3.1	27.7	3.1	28.3	1.0	28.2	1.4	28.5	0.3	28.4	0.7	28.1	1.7	28.0	2.1	28.2	1.4	28.0	2.1	28.0	2.1	27.7	3.1	28.1	1.7	27.9	2.4	28.0	2.1	27.8	2.8
Ford B15C 230 kV	243.5	239.9	1.5	238.8	1.9	239.7	1.6	238.5	2.1	238.3	2.1	237.8	2.3	235.6	3.2	233.8	4.0	241.0	1.0	240.5	1.2	242.2	0.5	241.8	0.7	239.2	1.8	238.3	2.1	239.6	1.6	238.9	1.9	237.9	2.3	236.3	3.0	238.8	1.9	237.7	2.4	238.6	2.0	237.3	2.5
Ford B16C 230 kV	243.3	239.7	1.5	238.6	1.9	239.5	1.6	238.4	2.0	238.1	2.1	237.6	2.3	235.4	3.2	233.6	4.0	240.8	1.0	240.3	1.2	242.0	0.5	241.7	0.7	239.0	1.8	238.1	2.1	239.4	1.6	238.7	1.9	237.7	2.3	236.1	3.0	238.7	1.9	237.5	2.4	238.4	2.0	237.1	2.5
Ford AB 27.6 kV	29.3	28.9	1.4	29.0	1.0	28.9	1.4	29.0	1.0	28.7	2.0	29.2	0.3	28.4	3.1	29.3	0.0	29.0	1.0	29.2	0.3	29.2	0.3	29.1	0.7	28.8	1.7	29.3	0.0	28.9	1.4	29.0	1.0	28.6	2.4	29.0	1.0	28.8	1.7	29.2	0.3	28.7	2.0	29.2	0.3
Oakville B15C	243.4	239.8	1.5	238.8	1.9	239.7	1.5	238.5	2.0	238.3	2.1	237.7	2.3	235.6	3.2	233.8	3.9	241.0	1.0	240.4	1.2	242.2	0.5	241.8	0.7	239.2	1.7	238.3	2.1	239.6	1.6	238.8	1.9	237.8	2.3	236.2	3.0	238.8	1.9	237.6	2.4	238.5	2.0	237.2	2.5
Oakville B16C	243.3	239.7	1.5	238.6	1.9	239.5	1.6	238.3	2.1	238.1	2.1	237.5	2.4	235.4	3.2	233.5	4.0	240.8	1.0	240.3	1.2	242.0	0.5	241.6	0.7	239.0	1.8	238.1	2.1	239.4	1.6	238.7	1.9	237.7	2.3	236.1	3.0	238.6	1.9	237.4	2.4	238.4	2.0	237.0	2.6
Oakville E 27.6 kV	28.6	28.2	1.4	28.0	2.1	28.2	1.4	27.9	2.4	28.0	2.1	27.8	2.8	27.7	3.1	28.0	2.1	28.3	1.0	28.2	1.4	28.5	0.3	28.4	0.7	28.1	1.7	27.9	2.4	28.1	1.7	28.0	2.1	27.9	2.4	28.0	2.1	28.1	1.7	27.8	2.8	28.0	2.1	27.8	2.8
Oakville Z 27.6 kV	27.3	26.9	1.5	26.6	2.6	26.8	1.8	26.6	2.6	26.7	2.2	26.5	2.9	26.4	3.3	26.6	2.6	27.0	1.1	26.9	1.5	27.1	0.7	27.0	1.1	26.8	1.8	26.6	2.6	26.8	1.8	26.6	2.6	26.6	2.6	26.6	2.6	26.7	2.2	26.5	2.9	26.7	2.2	26.4	3.3

System Impact Assessment Addendum Greenfield South GS – Appendix D

Table D-5

Scenario 1.3 Peak Load - Greenfield South on K23C, Cooksville solid
Single Contingencies

Monitored Element	Pre-contingency Voltage kV	Loss of R1K				Loss of R13K + Richview H2 bus (SC21)				Loss of R2K + Richview A1 bus (SC22)				Loss of R15K				Loss of R24C				Loss of K21C				Loss of K23C			
		pre-ULTC kV	%VD	post-ULTC kV	%VD	pre-ULTC kV	%VD	post-ULTC kV	%VD	pre-ULTC kV	%VD	post-ULTC kV	%VD	pre-ULTC kV	%VD	post-ULTC kV	%VD	pre-ULTC kV	%VD	post-ULTC kV	%VD	pre-ULTC kV	%VD	post-ULTC kV	%VD	pre-ULTC kV	%VD	post-ULTC kV	%VD
Richview AH1 230 kV	244.9	244.9	0.0	244.9	0.0	242.2	1.1	241.7	1.3	240.0	2.0	239.3	2.3	244.5	0.2	244.3	0.2	244.8	0.0	244.8	0.0	245.5	-0.2	245.5	-0.2	243.7	0.5	243.5	0.6
Richview AH2 230 kV	245.0	244.9	0.0	244.9	0.0	240.6	1.8	240.2	2.0	242.0	1.2	241.4	1.5	244.7	0.1	244.4	0.2	245.0	0.0	245.0	0.0	244.4	0.2	244.3	0.3	244.4	0.2	244.2	0.3
Greenfield 230 kV	245.3	245.5	-0.1	245.5	-0.1	242.0	1.3	241.4	1.6	242.0	1.3	241.2	1.7	244.9	0.2	244.6	0.3	245.1	0.1	245.1	0.1	244.0	0.5	243.8	0.6	0.0		0.0	
Greenfield G1 16.5 kV	16.7	16.7	0.0	16.7	0.0	16.7	0.0	16.7	0.0	16.7	0.0	16.7	0.0	16.7	0.0	16.7	0.0	16.7	0.0	16.7	0.0	16.7	0.0	16.7	0.0	0.0		0.0	
Greenfield G2 13.8 kV	13.9	13.9	0.0	13.9	0.0	13.9	0.0	13.9	0.0	13.9	0.0	13.9	0.0	13.9	0.0	13.9	0.0	13.9	0.0	13.9	0.0	13.9	0.0	13.9	0.0	0.0		0.0	
Manby E 230 kV	245.7	246.1	-0.2	246.1	-0.2	242.3	1.4	241.7	1.6	242.6	1.3	241.8	1.6	245.4	0.1	245.1	0.2	245.6	0.0	245.6	0.0	244.7	0.4	244.6	0.4	245.6	0.0	245.4	0.1
Manby E 118 kV	124.5	124.7	-0.2	124.7	-0.2	122.8	1.4	122.3	1.8	122.9	1.3	122.4	1.7	124.4	0.1	124.2	0.2	124.5	0.0	124.5	0.0	124.0	0.4	123.9	0.5	124.5	0.0	124.4	0.1
Manby W 230 kV	245.3	245.3	0.0	245.3	0.0	242.3	1.2	241.6	1.5	241.1	1.7	240.1	2.1	244.8	0.2	244.4	0.4	245.1	0.1	245.0	0.1	246.5	-0.5	246.5	-0.5	243.7	0.7	243.4	0.8
Manby W 118 kV	124.5	124.5	0.0	124.6	-0.1	123.0	1.2	122.5	1.6	122.4	1.7	121.7	2.2	124.3	0.2	124.0	0.4	124.4	0.1	124.4	0.1	125.1	-0.5	125.2	-0.6	123.7	0.6	123.5	0.8
Cooksville E 230 kV	244.6	244.7	0.0	244.8	-0.1	241.4	1.3	240.8	1.6	241.0	1.5	240.0	1.9	244.2	0.2	243.9	0.3	244.4	0.1	244.4	0.1	242.8	0.7	242.6	0.8	242.8	0.7	242.5	0.9
Cooksville W 230 kV	244.6	244.7	0.0	244.8	-0.1	241.4	1.3	240.8	1.6	241.0	1.5	240.0	1.9	244.2	0.2	243.9	0.3	244.4	0.1	244.4	0.1	242.8	0.7	242.6	0.8	242.8	0.7	242.5	0.9
Lorne Park B15C	244.1	244.2	0.0	244.3	-0.1	240.9	1.3	240.3	1.6	240.5	1.5	239.5	1.9	243.8	0.1	243.4	0.3	243.9	0.1	243.9	0.1	242.3	0.7	242.1	0.8	242.3	0.7	242.0	0.9
Lorne Park B16C	244.1	244.2	0.0	244.2	0.0	240.8	1.4	240.2	1.6	240.5	1.5	239.5	1.9	243.7	0.2	243.3	0.3	243.8	0.1	243.8	0.1	242.2	0.8	242.1	0.8	242.3	0.7	242.0	0.9
Lorne Park B 27.6 kV	28.1	28.1	0.0	28.1	0.0	27.8	1.1	27.6	1.8	27.7	1.4	27.5	2.1	28.1	0.0	28.0	0.4	28.1	0.0	28.1	0.0	27.9	0.7	27.9	0.7	27.9	0.7	27.9	0.7
Lorne Park J 27.6 kV	28.6	28.6	0.0	28.6	0.0	28.2	1.4	28.1	1.7	28.2	1.4	28.0	2.1	28.6	0.0	28.5	0.3	28.6	0.0	28.6	0.0	28.4	0.7	28.4	0.7	28.4	0.7	28.3	1.0
Ford B15C 230 kV	243.4	243.5	0.0	243.6	-0.1	240.2	1.3	239.5	1.6	239.8	1.5	238.8	1.9	243.1	0.1	242.7	0.3	243.2	0.1	243.2	0.1	241.6	0.7	241.4	0.8	241.6	0.7	241.3	0.9
Ford B16C 230 kV	243.3	243.4	0.0	243.4	0.0	240.0	1.4	239.3	1.6	239.7	1.5	238.6	1.9	242.9	0.2	242.5	0.3	243.0	0.1	243.0	0.1	241.4	0.8	241.3	0.8	241.5	0.7	241.1	0.9
Ford AB 27.6 kV	29.3	29.3	0.0	29.3	0.0	28.9	1.4	29.1	0.7	28.9	1.4	29.0	1.0	29.3	0.0	29.2	0.3	29.3	0.0	29.3	0.0	29.1	0.7	29.1	0.7	29.1	0.7	29.1	0.7
Oakville B15C	243.4	243.5	0.0	243.5	0.0	240.2	1.3	239.5	1.6	239.8	1.5	238.8	1.9	243.0	0.2	242.6	0.3	243.2	0.1	243.1	0.1	241.6	0.7	241.4	0.8	241.6	0.7	241.3	0.9
Oakville B16C	243.2	243.3	0.0	243.4	-0.1	240.0	1.3	239.3	1.6	239.6	1.5	238.6	1.9	242.8	0.2	242.5	0.3	243.0	0.1	243.0	0.1	241.4	0.7	241.2	0.8	241.4	0.7	241.1	0.9
Oakville E 27.6 kV	28.6	28.6	0.0	28.6	0.0	28.2	1.4	28.1	1.7	28.2	1.4	28.0	2.1	28.6	0.0	28.5	0.3	28.6	0.0	28.6	0.0	28.4	0.7	28.3	1.0	28.4	0.7	28.3	1.0
Oakville Z 27.6 kV	27.3	27.3	0.0	27.3	0.0	26.9	1.5	26.7	2.2	26.9	1.5	26.6	2.6	27.2	0.4	27.2	0.4	27.2	0.4	27.2	0.4	27.1	0.7	27.0	1.1	27.1	0.7	27.0	1.1

System Impact Assessment Addendum Greenfield South GS – Appendix D

Table D-6

Scenario 1.3 Peak Load - Greenfield South on K23C, Cooksville solid Double Contingencies

Monitored Element	Pre-contingency Voltage kV	Loss of R1K + R2K + Richview A1 bus (SC22)				Loss of R13K + R15K + Richview H2 bus (SC21)				Loss of K21C + K23C				Loss of Manby SC21+ T3+ T13+ T1+ R2K + Richview A1 bus (SC22) [Manby W A1L2 B/F]				R1K out + loss of R13K				R2K out + loss of R15K				K21C out + loss of R2K (similar for loss of R15K)				K23C out + loss of R13K (similar for loss of R1K)				R2K out + loss of R24C (similar with R15K out)				R13K out + loss of R24C (similar with R1K out)				R2K out + loss of K23C (similar with R15K out)			
		pre-ULTC	post-ULTC	pre-ULTC	post-ULTC	pre-ULTC	post-ULTC	pre-ULTC	post-ULTC	pre-ULTC	post-ULTC	pre-ULTC	post-ULTC	pre-ULTC	post-ULTC	pre-ULTC	post-ULTC	pre-ULTC	post-ULTC	pre-ULTC	post-ULTC	pre-ULTC	post-ULTC	pre-ULTC	post-ULTC	pre-ULTC	post-ULTC	pre-ULTC	post-ULTC	pre-ULTC	post-ULTC	pre-ULTC	post-ULTC	pre-ULTC	post-ULTC										
		kV	%VD	kV	%VD	kV	%VD	kV	%VD	kV	%VD	kV	%VD	kV	%VD	kV	%VD	kV	%VD	kV	%VD	kV	%VD	kV	%VD	kV	%VD	kV	%VD	kV	%VD	kV	%VD	kV	%VD	kV	%VD								
Richview AH1 230 kV	244.9	239.9	2.0	239.3	2.3	241.8	1.3	241.1	1.6	244.6	0.1	244.4	0.2	237.0	3.2	235.9	3.7	242.3	1.1	241.9	1.2	239.8	2.1	239.7	2.1	239.9	2.0	239.1	2.4	240.7	1.7	240.0	2.0	239.8	2.1	239.0	2.4	242.2	1.1	241.7	1.3	238.4	2.7	237.4	3.1
Richview AH2 230 kV	245.0	241.9	1.3	241.3	1.5	240.2	2.0	239.5	2.2	243.3	0.7	242.9	0.9	239.4	2.3	238.3	2.7	239.8	2.1	239.6	2.2	242.8	0.9	242.6	1.0	241.8	1.3	241.1	1.6	239.6	2.2	238.9	2.5	242.1	1.2	241.4	1.5	240.4	1.9	240.0	2.0	241.1	1.6	240.2	2.0
Greenfield 230 kV	245.3	242.2	1.3	241.3	1.6	241.6	1.5	240.6	1.9	0.0	0.0	0.0	0.0	238.6	2.7	237.1	3.3	243.9	0.6	243.5	0.7	243.6	0.7	243.3	0.8	241.6	1.5	240.8	1.8	0.0	0.0	241.7	1.5	240.8	1.8	242.0	1.3	241.4	1.6	0.0	0.0	0.0	0.0		
Greenfield G1 16.5 kV	16.7	16.7	0.0	16.7	0.0	16.7	0.0	16.7	0.0	0.0	0.0	0.0	0.0	16.7	0.0	16.7	0.0	16.7	0.0	16.7	0.0	16.7	0.0	16.7	0.0	16.7	0.0	16.7	0.0	0.0	0.0	16.7	0.0	16.7	0.0	16.7	0.0	16.7	0.0	16.7	0.0	16.7	0.0	16.7	0.0
Greenfield G2 13.8 kV	13.9	13.9	0.0	13.9	0.0	13.9	0.0	13.9	0.0	0.0	0.0	0.0	0.0	13.9	0.0	13.9	0.0	13.9	0.0	13.9	0.0	13.9	0.0	13.9	0.0	13.9	0.0	13.9	0.0	0.0	0.0	13.9	0.0	13.9	0.0	13.9	0.0	13.9	0.0	13.9	0.0	13.9	0.0	13.9	0.0
Manby E 230 kV	245.7	242.9	1.1	242.0	1.5	241.9	1.5	241.0	1.9	244.5	0.5	244.1	0.7	239.5	2.5	238.1	3.1	245.1	0.2	244.6	0.4	243.8	0.8	243.5	0.9	242.2	1.4	241.5	1.7	242.0	1.5	241.1	1.9	242.4	1.3	241.5	1.7	242.3	1.4	241.7	1.6	242.4	1.3	241.4	1.8
Manby E 118 kV	124.5	123.1	1.1	122.5	1.6	122.6	1.5	121.9	2.1	123.9	0.5	123.6	0.7	121.4	2.5	120.4	3.3	124.2	0.2	123.9	0.5	123.5	0.8	123.3	1.0	122.8	1.4	122.2	1.8	122.6	1.5	122.0	2.0	122.9	1.3	122.2	1.8	122.8	1.4	122.3	1.8	122.8	1.4	122.1	1.9
Manby W 230 kV	245.3	241.2	1.7	240.1	2.1	241.7	1.5	240.5	2.0	245.5	-0.1	245.3	0.0	235.8	3.9	233.9	4.6	242.7	1.1	242.2	1.3	244.4	0.4	244.1	0.5	241.3	1.6	239.9	2.2	240.5	2.0	239.5	2.4	240.7	1.9	239.5	2.4	242.3	1.2	241.6	1.5	238.7	2.7	237.1	3.3
Manby W 118 kV	124.5	122.4	1.7	121.7	2.2	122.7	1.4	121.9	2.1	124.6	-0.1	124.5	0.0	119.2	4.3	117.4	5.7	123.2	1.0	122.9	1.3	124.1	0.3	123.9	0.5	122.5	1.6	121.6	2.3	122.1	1.9	121.3	2.6	122.2	1.8	121.4	2.5	123.0	1.2	122.5	1.6	121.1	2.7	120.0	3.6
Cooksville E 230 kV	244.6	241.1	1.4	240.1	1.8	240.9	1.5	239.8	2.0	237.6	2.9	236.7	3.2	236.7	3.2	235.0	3.9	242.2	1.0	241.8	1.1	243.4	0.5	243.0	0.7	240.3	1.8	239.5	2.1	239.3	2.2	238.3	2.6	240.5	1.7	239.4	2.1	241.5	1.3	240.8	1.6	238.1	2.7	236.6	3.3
Cooksville W 230 kV	244.6	241.1	1.4	240.1	1.8	240.9	1.5	239.8	2.0	237.6	2.9	236.7	3.2	236.7	3.2	235.0	3.9	242.2	1.0	241.8	1.1	243.4	0.5	243.0	0.7	240.3	1.8	239.5	2.1	239.3	2.2	238.3	2.6	240.5	1.7	239.4	2.1	241.5	1.3	240.8	1.6	238.1	2.7	236.6	3.3
Lorne Park B15C	244.1	240.6	1.4	239.6	1.8	240.4	1.5	239.3	2.0	237.1	2.9	236.2	3.2	236.2	3.2	234.5	3.9	241.7	1.0	241.3	1.1	242.9	0.5	242.5	0.7	239.9	1.7	239.0	2.1	238.8	2.2	237.8	2.6	240.0	1.7	238.8	2.2	241.0	1.3	240.3	1.6	237.6	2.7	236.1	3.3
Lorne Park B16C	244.1	240.5	1.5	239.5	1.9	240.3	1.6	239.2	2.0	237.0	2.9	236.1	3.3	236.2	3.2	234.4	4.0	241.7	1.0	241.2	1.2	242.8	0.5	242.4	0.7	239.8	1.8	238.9	2.1	238.8	2.2	237.7	2.6	239.9	1.7	238.8	2.2	240.9	1.3	240.2	1.6	237.6	2.7	236.0	3.3
Lorne Park B 27.6 kV	28.1	27.7	1.4	27.5	2.1	27.7	1.4	27.5	2.1	27.3	2.8	27.4	2.5	27.2	3.2	27.2	3.2	27.9	0.7	27.8	1.1	28.0	0.4	27.9	0.7	27.6	1.8	27.5	2.1	27.5	2.1	27.3	2.8	27.7	1.4	27.5	2.1	27.8	1.1	27.6	1.8	27.4	2.5	27.4	2.5
Lorne Park J 27.6 kV	28.6	28.2	1.4	28.0	2.1	28.2	1.4	28.0	2.1	27.8	2.8	27.9	2.4	27.7	3.1	27.7	3.1	28.3	1.0	28.3	1.0	28.5	0.3	28.4	0.7	28.1	1.7	28.0	2.1	28.0	2.1	27.8	2.8	28.1	1.7	27.9	2.4	28.2	1.4	28.1	1.7	27.8	2.8	27.9	2.4
Ford B15C 230 kV	243.4	239.9	1.4	238.9	1.8	239.7	1.5	238.6	2.0	236.4	2.9	235.4	3.3	235.6	3.2	233.8	3.9	241.0	1.0	240.5	1.2	242.2	0.5	241.8	0.7	239.2	1.7	238.3	2.1	238.1	2.2	237.1	2.6	239.3	1.7	238.1	2.2	240.3	1.3	239.6	1.6	237.0	2.6	235.3	3.3
Ford B16C 230 kV	243.3	239.7	1.5	238.7	1.9	239.5	1.6	238.4	2.0	236.2	2.9	235.2	3.3	235.4	3.2	233.5	4.0	240.9	1.0	240.4	1.2	242.0	0.5	241.6	0.7	239.0	1.8	238.1	2.1	238.0	2.2	236.9	2.6	239.2	1.7	237.9	2.2	240.1	1.3	239.4	1.6	236.8	2.7	235.1	3.4
Ford AB 27.6 kV	29.3	28.9	1.4	29.0	1.0	28.9	1.4	29.0	1.0	28.5	2.7	29.2	0.3	28.4	3.1	29.3	0.0	29.0	1.0	29.3	0.0	29.2	0.3	29.1	0.7	28.8	1.7	29.3	0.0	28.7	2.0	29.1	0.7	28.8	1.7	29.3	0.0	28.9	1.4	29.1	0.7	28.5	2.7	29.2	0.3
Oakville B15C	243.4	239.8	1.5	238.8	1.9	239.7	1.5	238.5	2.0	236.4	2.9	235.4	3.3	235.5	3.2	233.7	4.0	241.0	1.0	240.5	1.2	242.1	0.5	241.7	0.7	239.1	1.8	238.3	2.1	238.1	2.2	237.0	2.6	239.3	1.7	238.1	2.2	240.2	1.3	239.5	1.6	236.9	2.7	235.3	3.3
Oakville B16C	243.2	239.7	1.4	238.6	1.9	239.5	1.5	238.4	2.0	236.2	2.9	235.2	3.3	235.4	3.2	233.5	4.0	240.8	1.0	240.3	1.2	242.0	0.5	241.6	0.7	239.0	1.7	238.1	2.1	237.9	2.2	236.8	2.6	239.1	1.7	237.9	2.2	240.1	1.3	239.3	1.6	236.8	2.6	235.1	3.3
Oakville E 27.6 kV	28.6	28.2	1.4	28.0	2.1	28.2	1.4	27.9	2.4	27.8	2.8	27.9	2.4	27.7	3.1	28.0	2.1	28.3	1.0	28.2	1.4	28.4	0.7	28.4	0.7	28.1	1.7	27.9	2.4	28.0	2.1	27.7	3.1	28.1	1.7	27.9	2.4	28.2	1.4	28.1	1.7	27.8	2.8	27.8	2.8
Oakville Z 27.6 kV	27.3	26.9	1.5	26.6	2.6	26.8	1.8	26.6	2.6	26.5	2.9	26.5	2.9	26.4	3.3	26.6	2.6	27.0	1.1	26.9	1.5	27.1	0.7	27.0	1.1	26.8	1.8	26.6	2.6	26.7	2.2	26.4	3.3	26.8	1.8	26.5	2.9	26.9	1.5	26.7	2.2	26.5	2.9	26.5	2.9

– End of Section –

-intentionally left blank-

Appendix E

Dynamic Control Systems Testing

Figure E-1:
G1 Exciter - Open Circuit Test -5% Vref Change
 Required Efd after 50 ms is -3.28 pu.

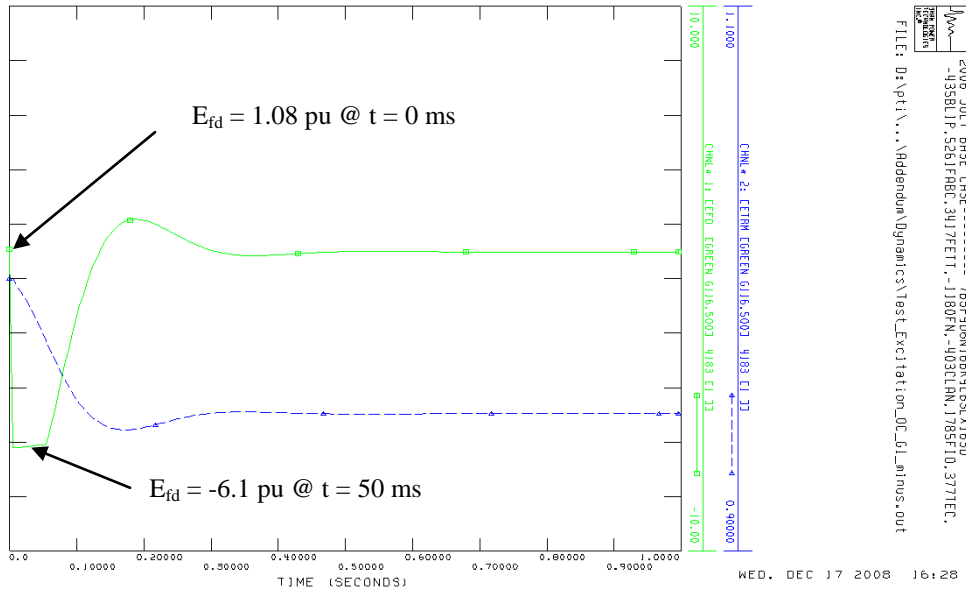
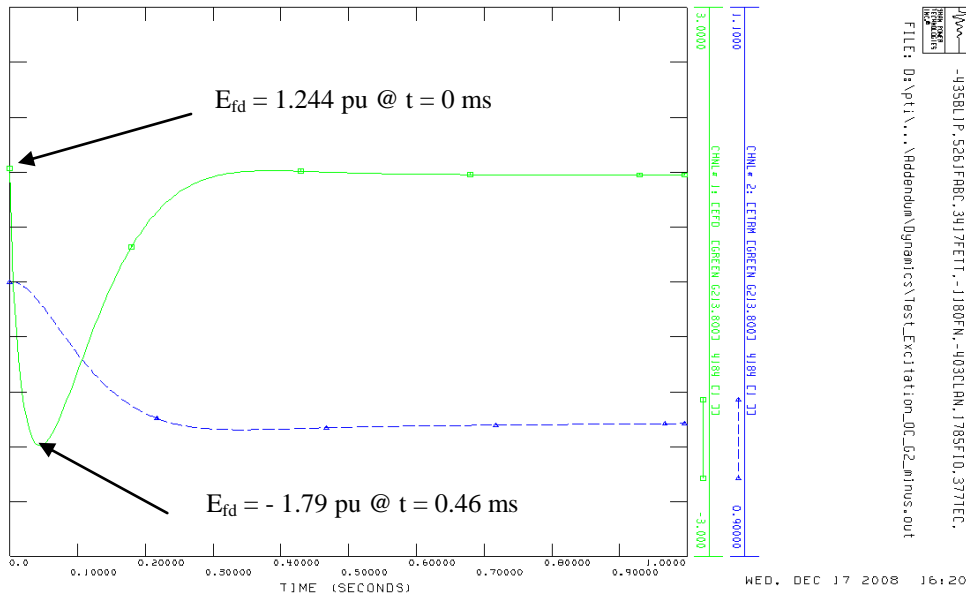

Figure E-2:
G2 Exciter – Open Circuit Test -5% Vref Change ($K_A=600$; $K_M = 2$)
 Required Efd after 50 ms is -3.91 pu.



-End of Section-

Appendix F

Transient Stability Analysis

Greenfield South GS connected to R24C

Figure F-1:
C.1 / R24C - R13K Three-phase fault at Richview TS - G1 response

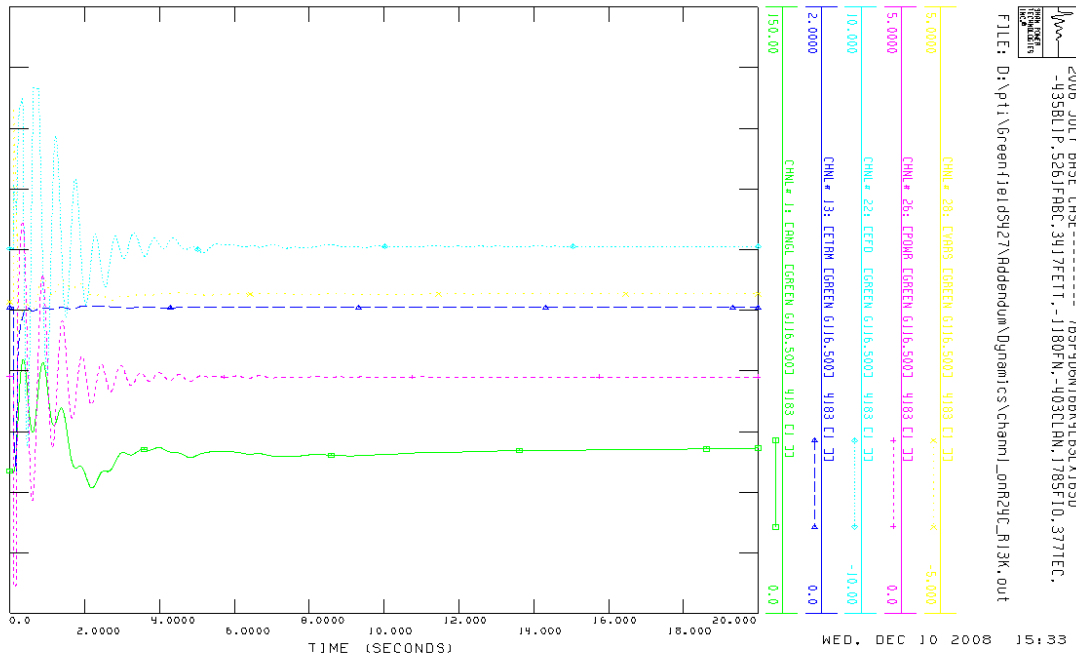

Figure F-2:
C.1 / R24C - R13K Three-phase fault at Richview TS - G2 response

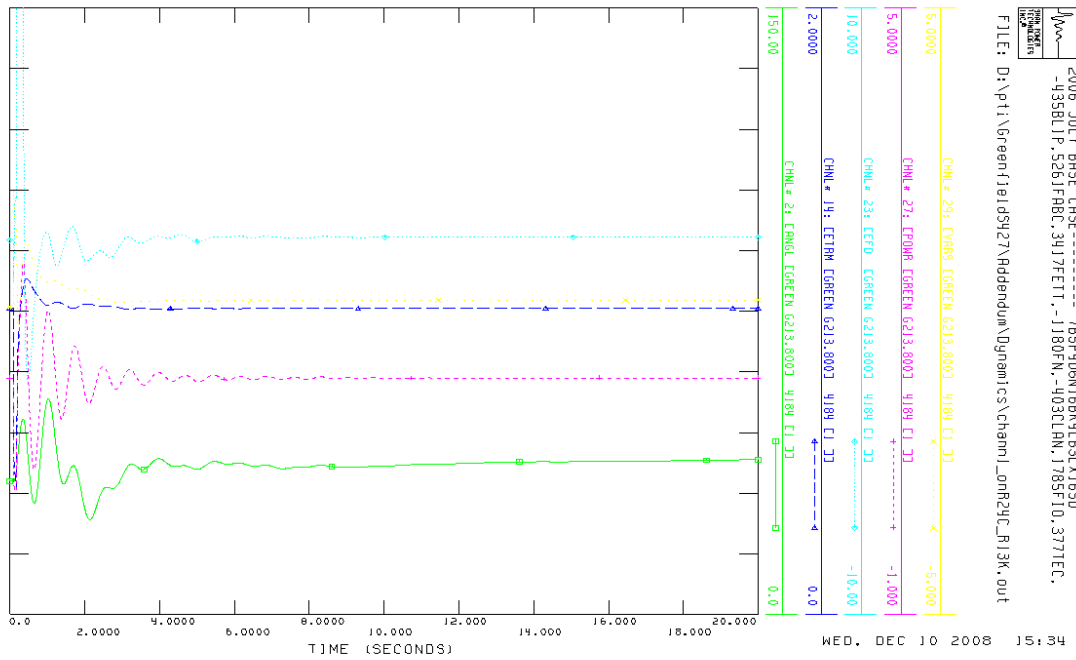

Figure F-3:
C.1 / R24C - R13K Three-phase fault at Richview TS - Major generator angles

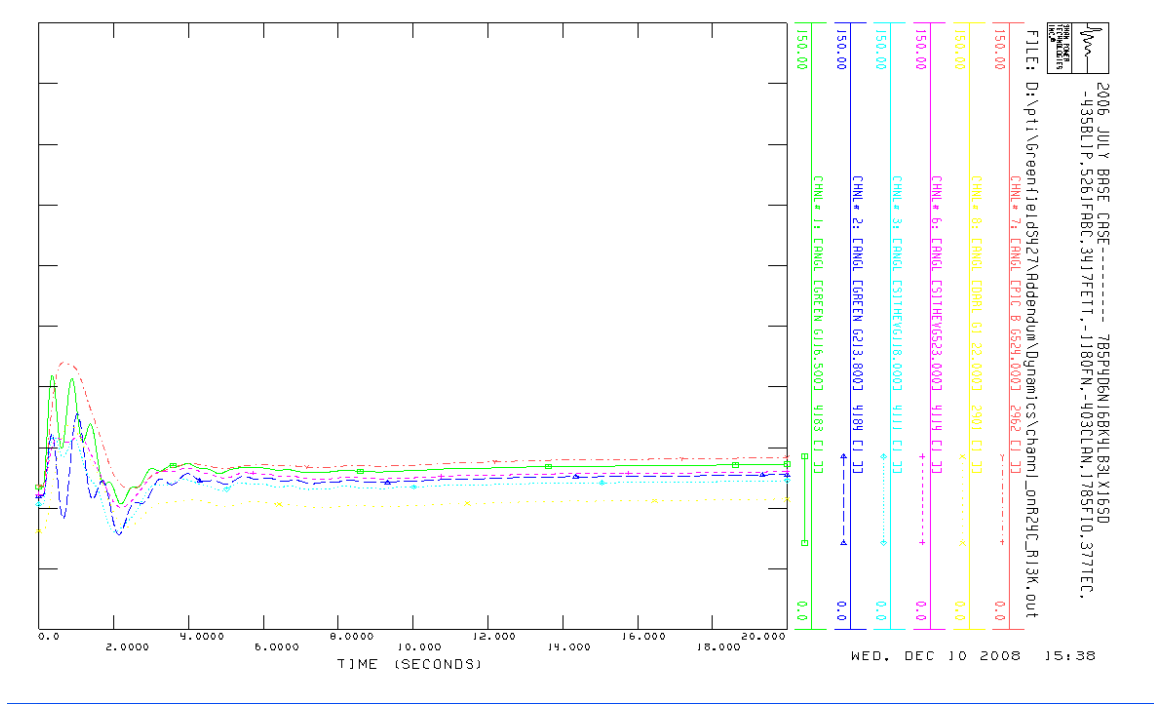

Figure F-4:
C.2 / R24C - R1K + R2K Phase-to-ground fault at Richview TS - G1 response

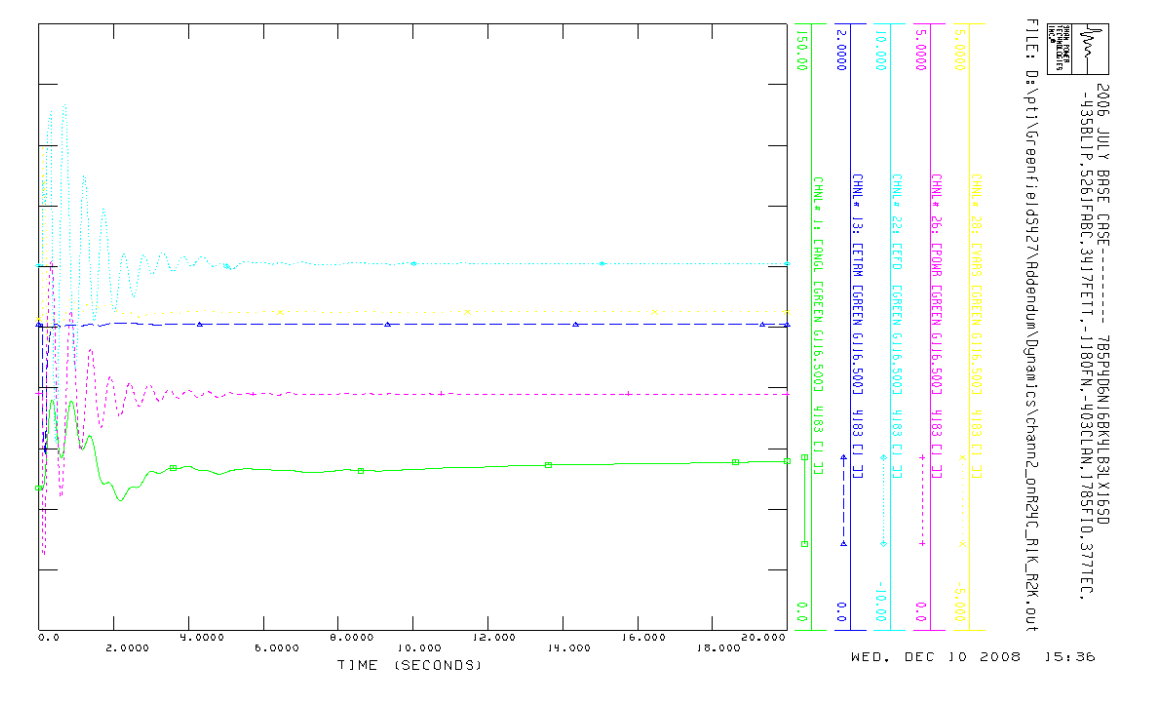

Figure F-5:
C.2/ R24C - R1K + R2K Phase-to-ground fault at Richview TS – G2 response

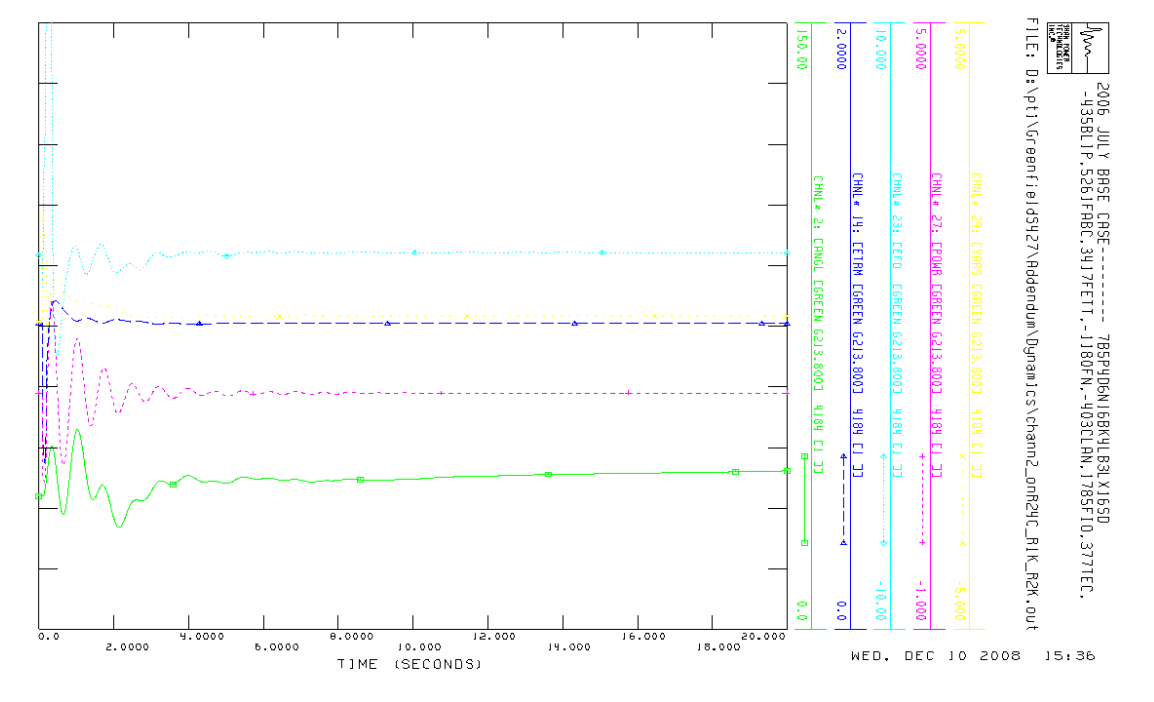

Figure F-6:
C.2/ R24C - R1K + R2K Phase-to-ground fault at Richview TS – Major generator angles

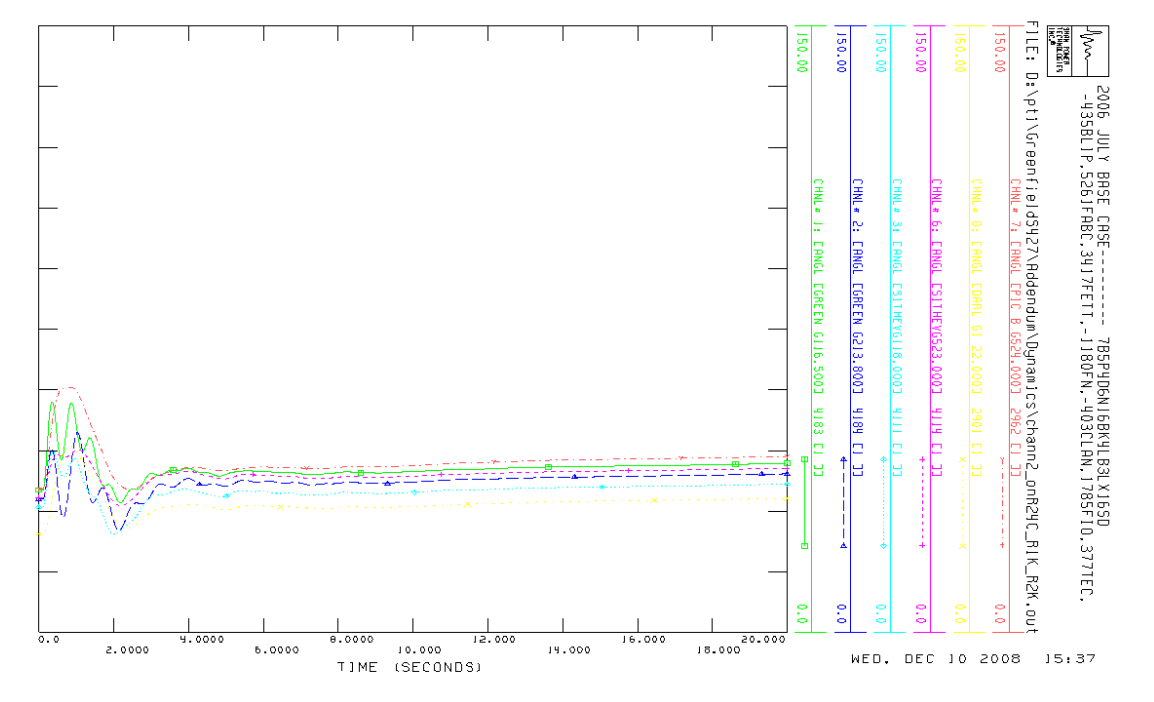

Figure F-7:
C.3 / R24C - K21C Three-phase fault at Cooksville - G1 response

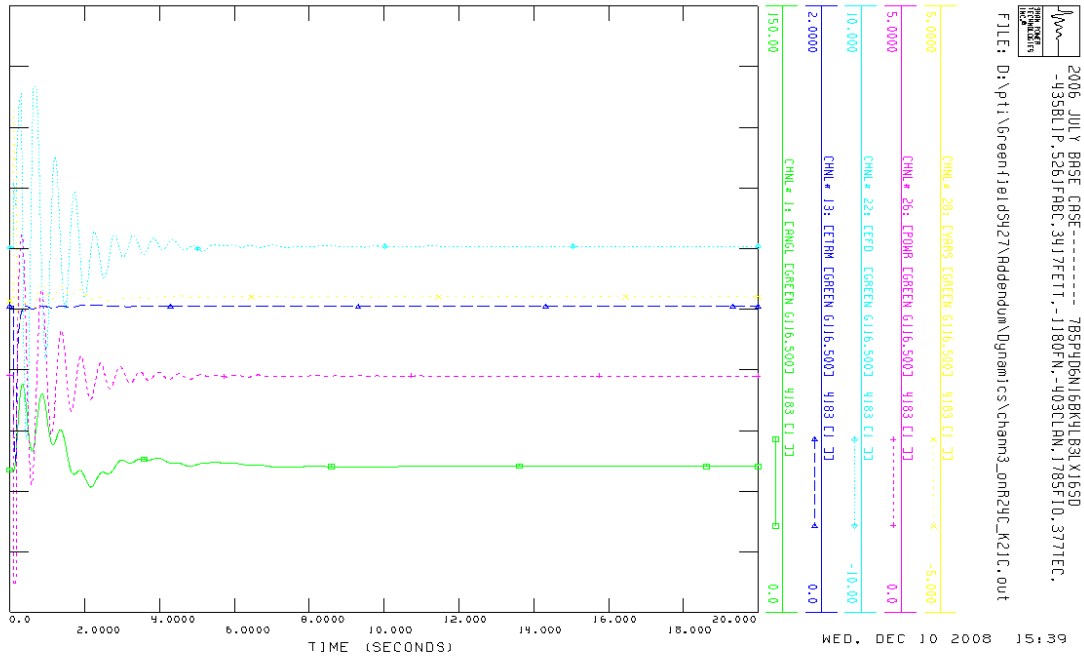

Figure F-8:
C.3 / R24C - K21C Three-phase fault at Cooksville - G2 response

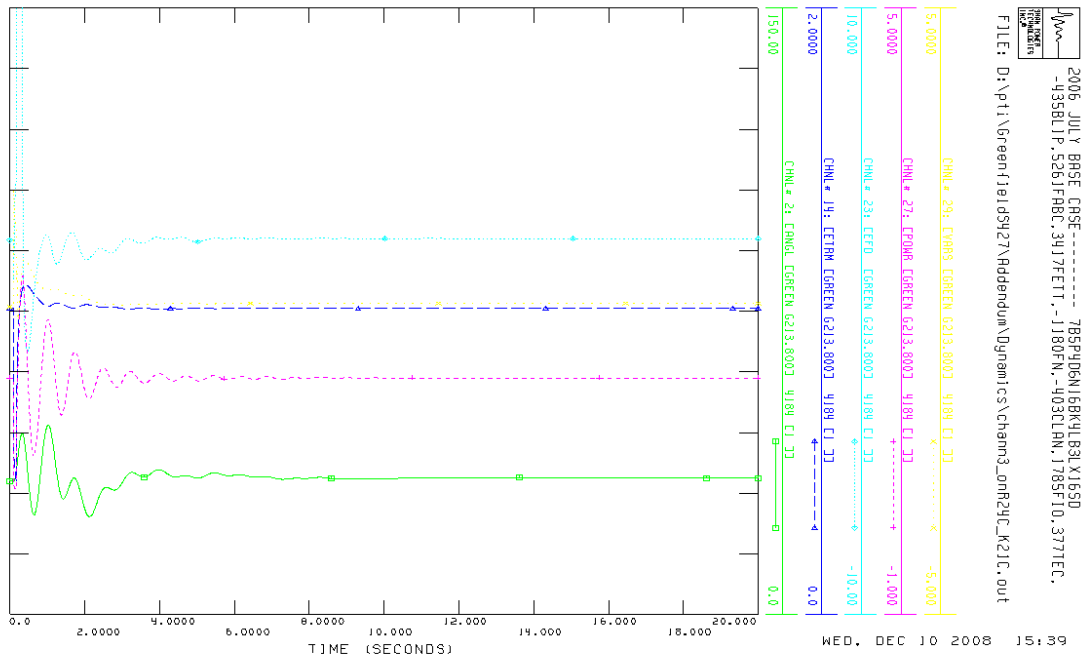

Figure F-9:
C.3 / R24C - K21C Three-phase fault at Cooksville - Major generator angles

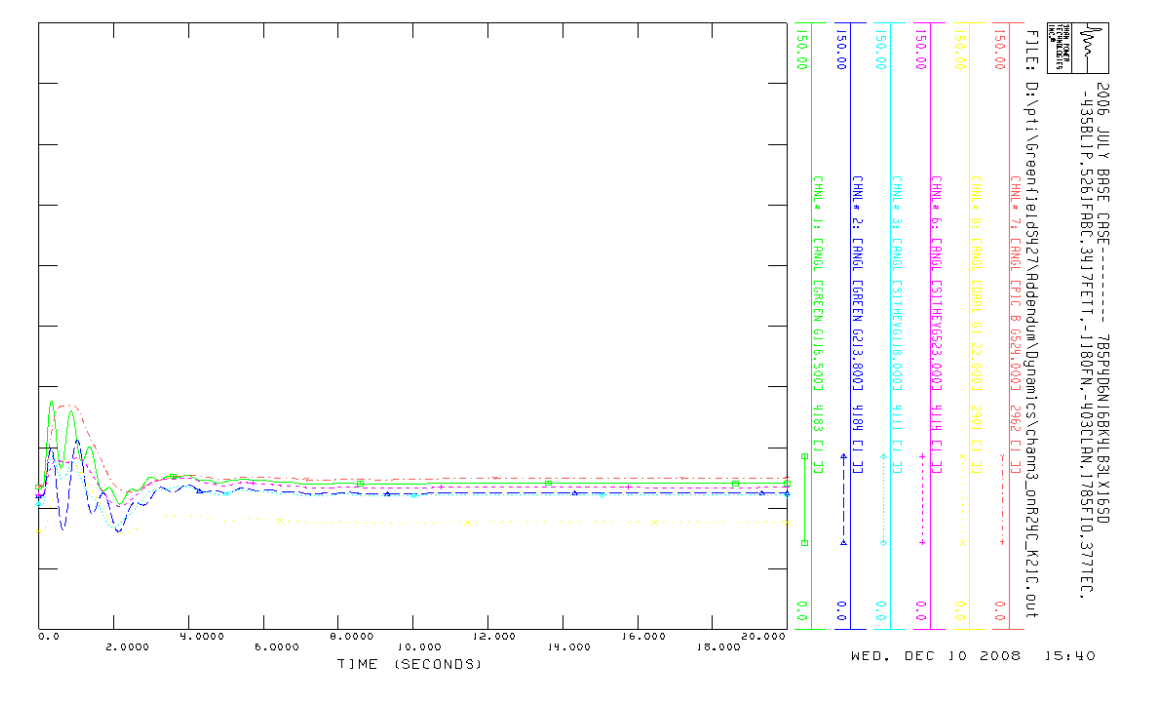

Figure F-10:
C.4 / R24C - K21C and K23C Phase-to-ground fault at Cooksville - G1 response

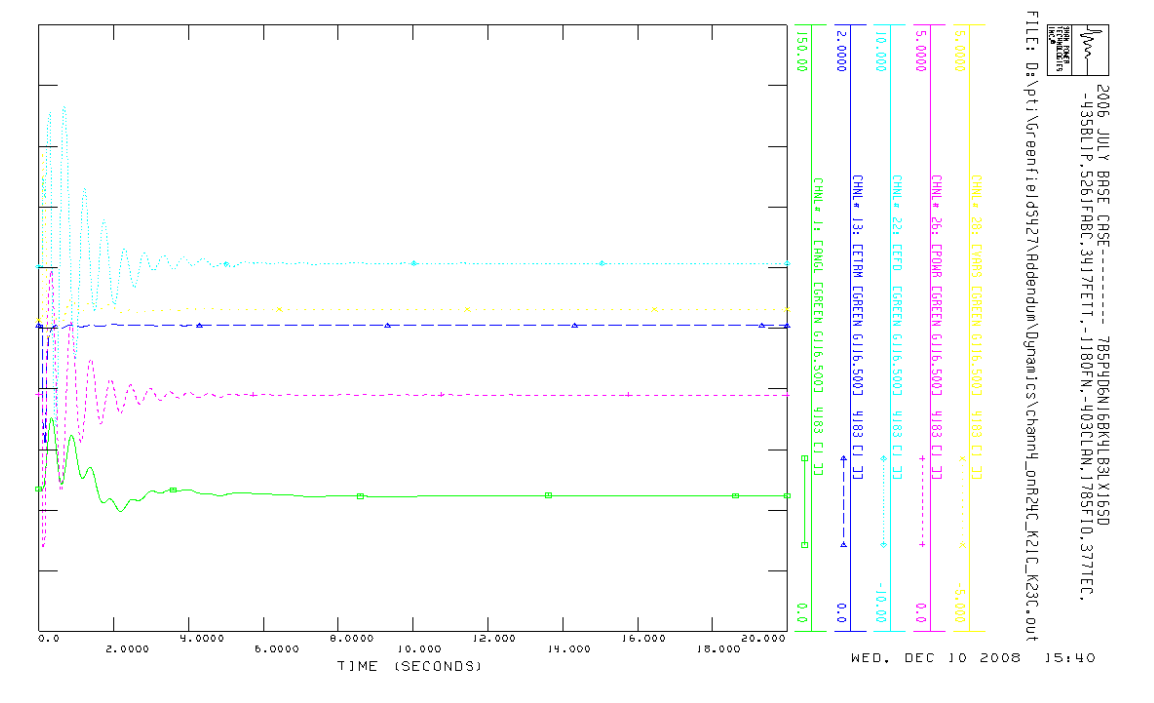

Figure F-11:
C.4 / R24C - K21C and K23C Phase-to-ground fault at Cooksville - G2 response

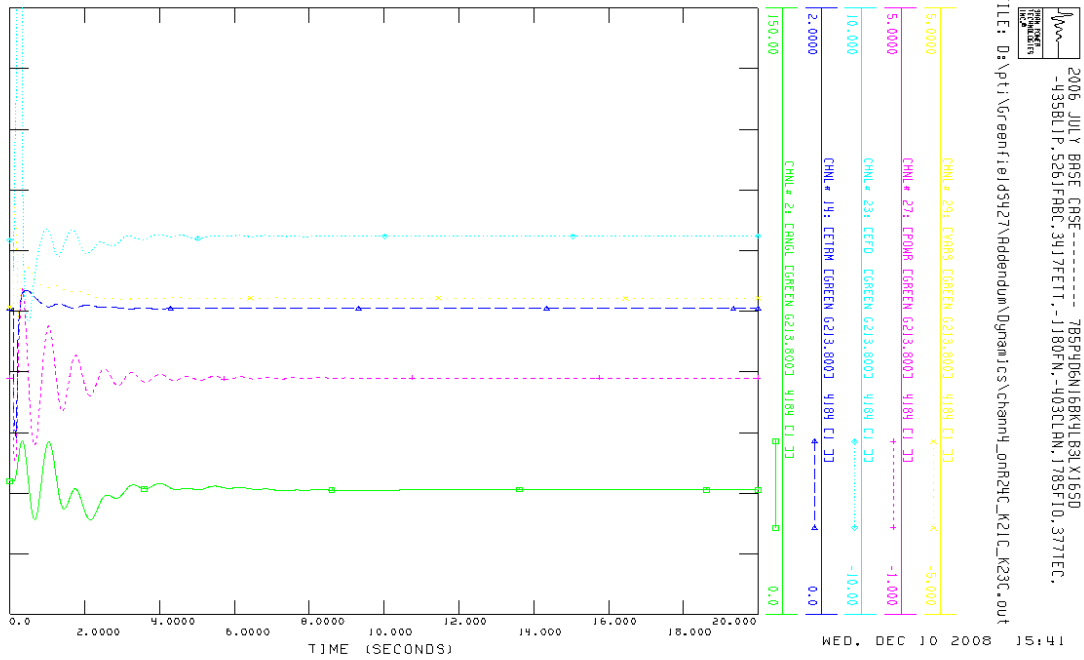

Figure F-12:
C.4 / R24C - K21C and K23C Phase-to-ground fault at Cooksville - Major generator angles

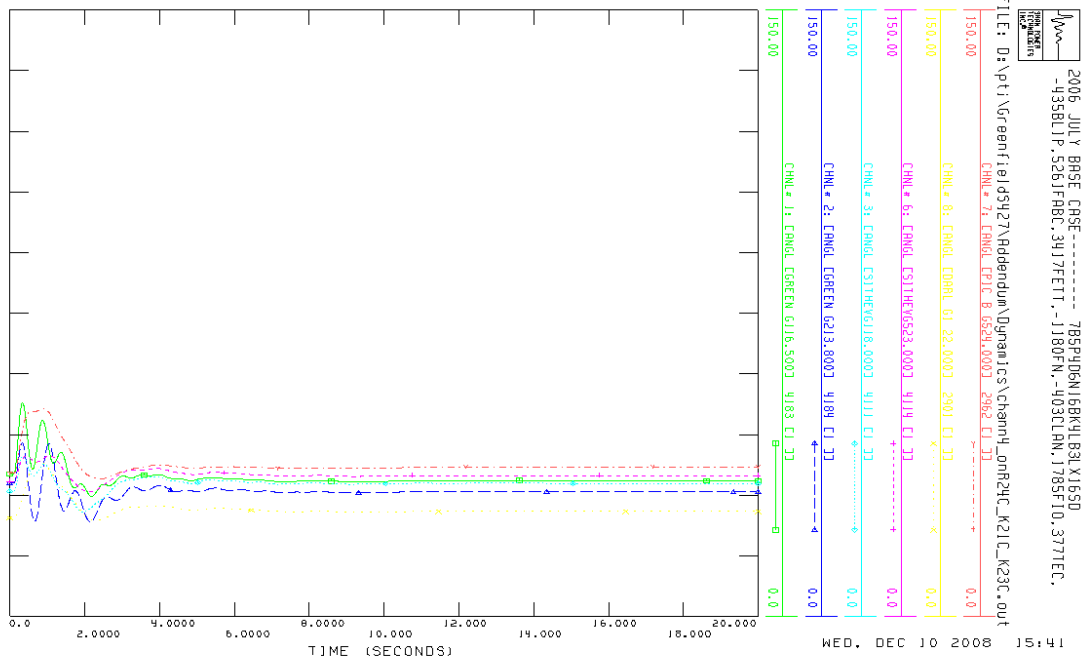

Figure F-13:
C.5 / R24C - K21C Phase-to-ground fault at Cooksville and Cooksville L21L23 Breaker Failure (K23C trip) - G1 response

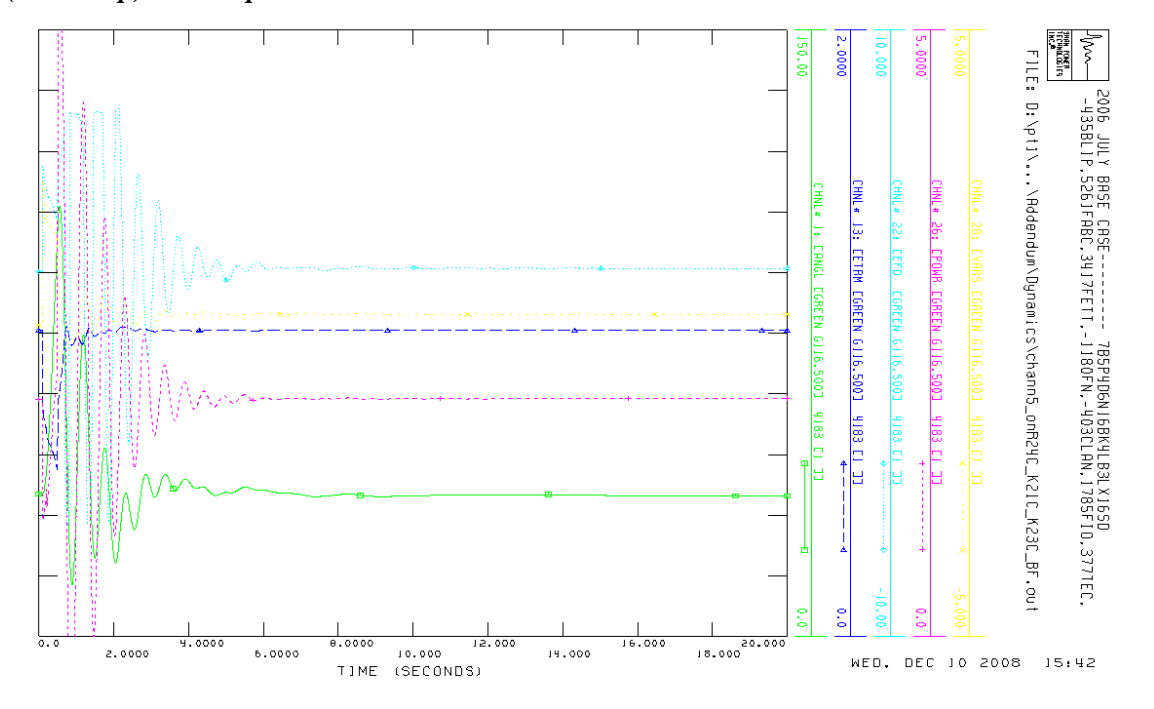

Figure F-14:
C.5 / R24C - K21C Phase-to-ground fault at Cooksville and Cooksville L21L23 Breaker Failure (K23C trip) - G2 response

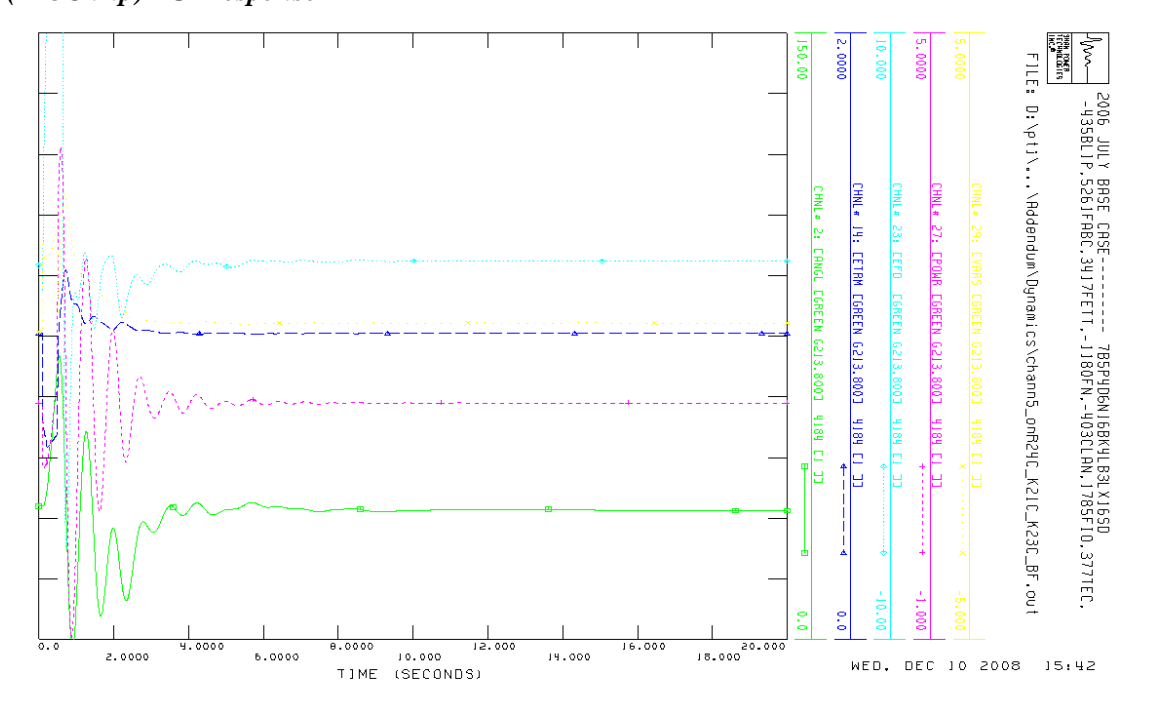

Figure F - 15:
C.5 / R24C - K21C Phase-to-ground fault at Cooksville and Cooksville L21L23 Breaker Failure (K23C trip) - Major generator angles

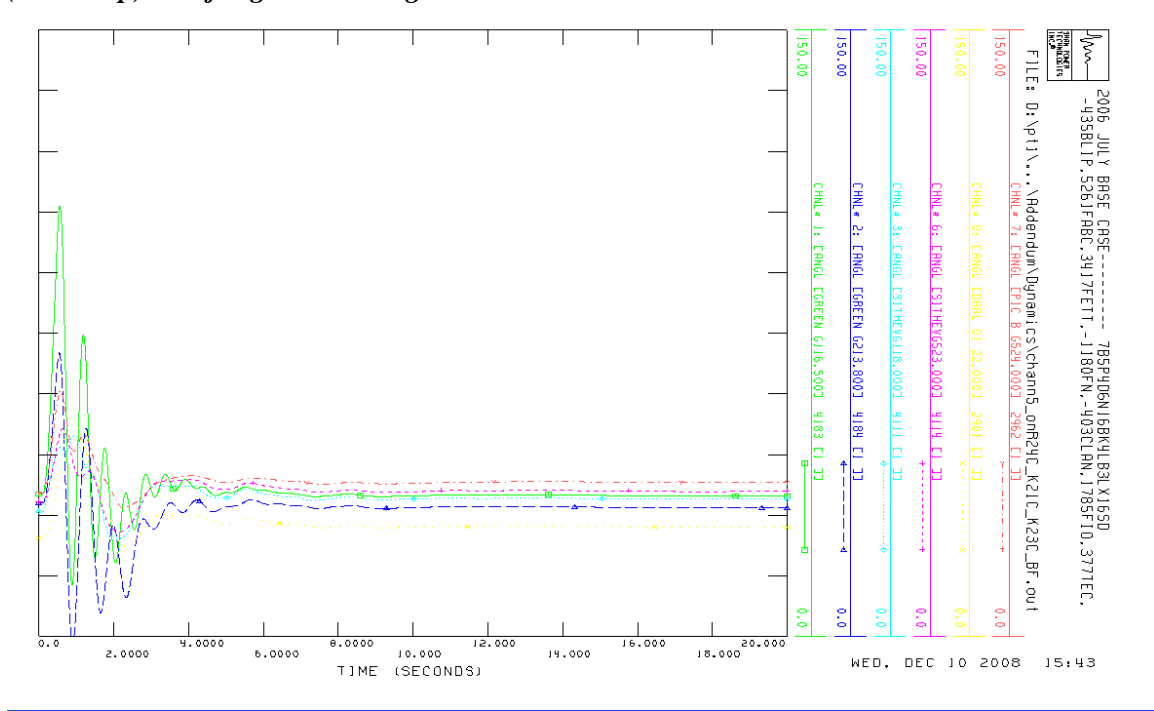

Figure F - 16:
C.6 / R24C - R1K Phase-to-ground fault at Richview and Richview A2L19 Breaker Failure (R19T trip) - G1 response

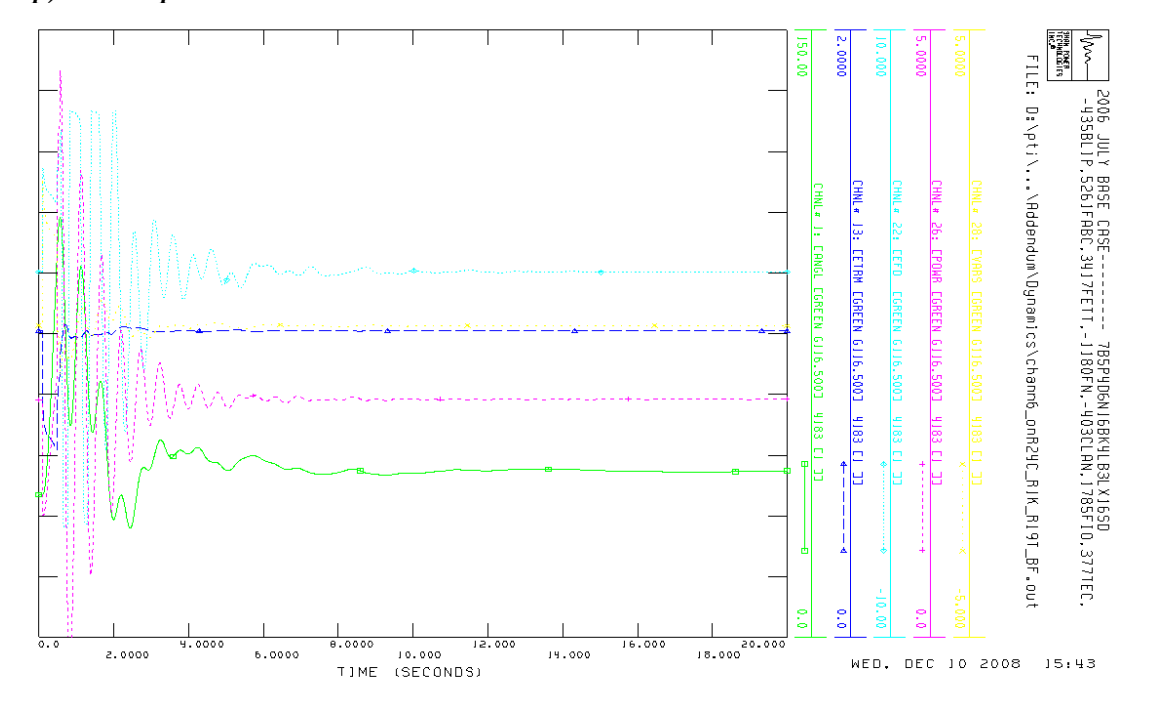

Figure F-17:
C.6 / R24C - R1K Phase-to-ground fault at Richview and Richview A2L19 Breaker Failure (R19T trip) - G2 response

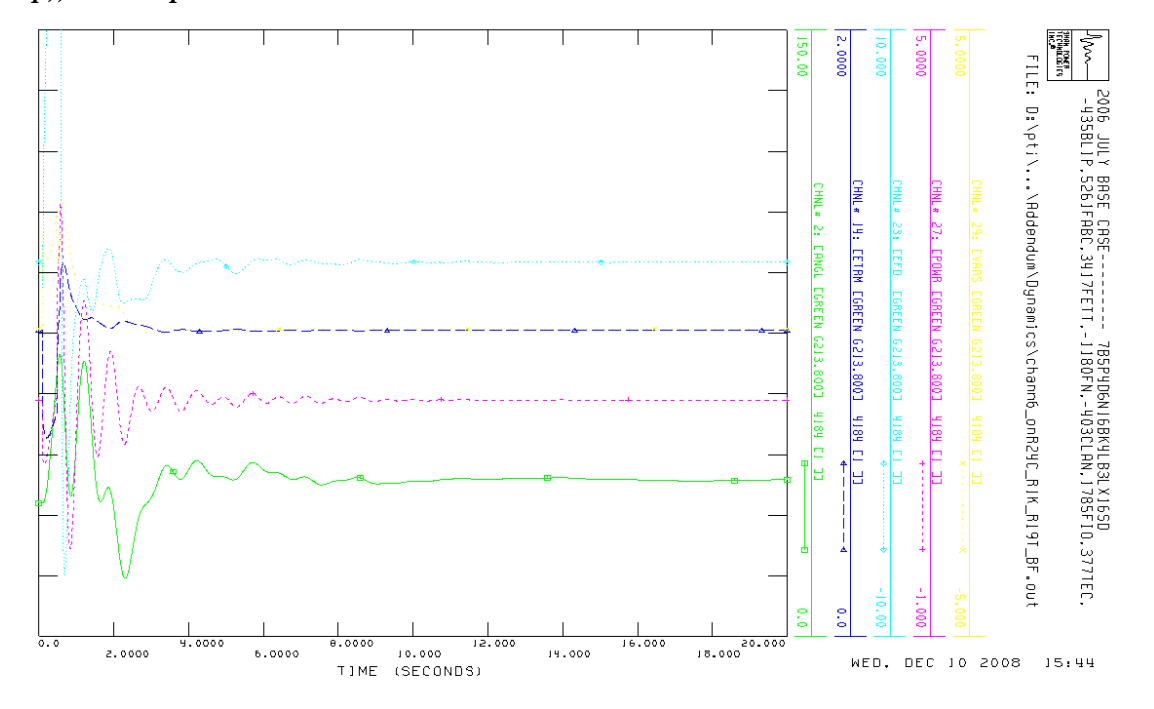

Figure F-18:
C.6 / R24C - R1K Phase-to-ground fault at Richview and Richview A2L19 Breaker Failure (R19T trip) - Major generator angles

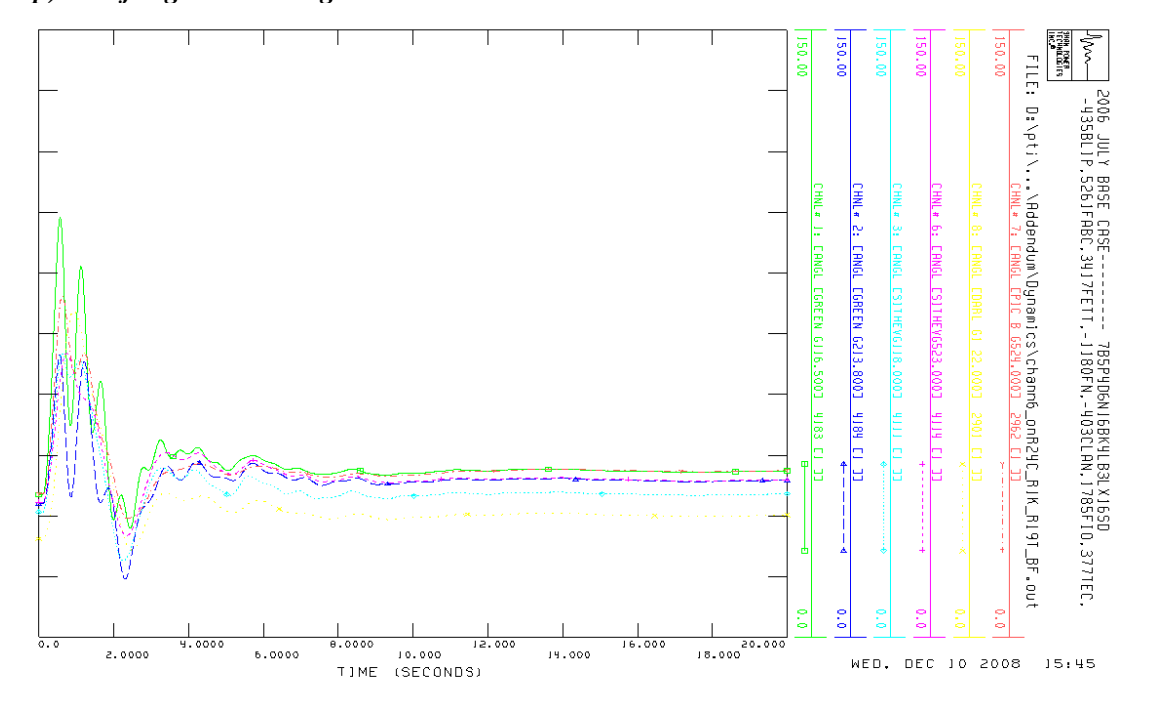

Figure F- 19:
C.7 / R24C - R13K Phase-to-ground fault at Richview and Richview H2L22 Breaker Failure (P22R trip) - G1 response

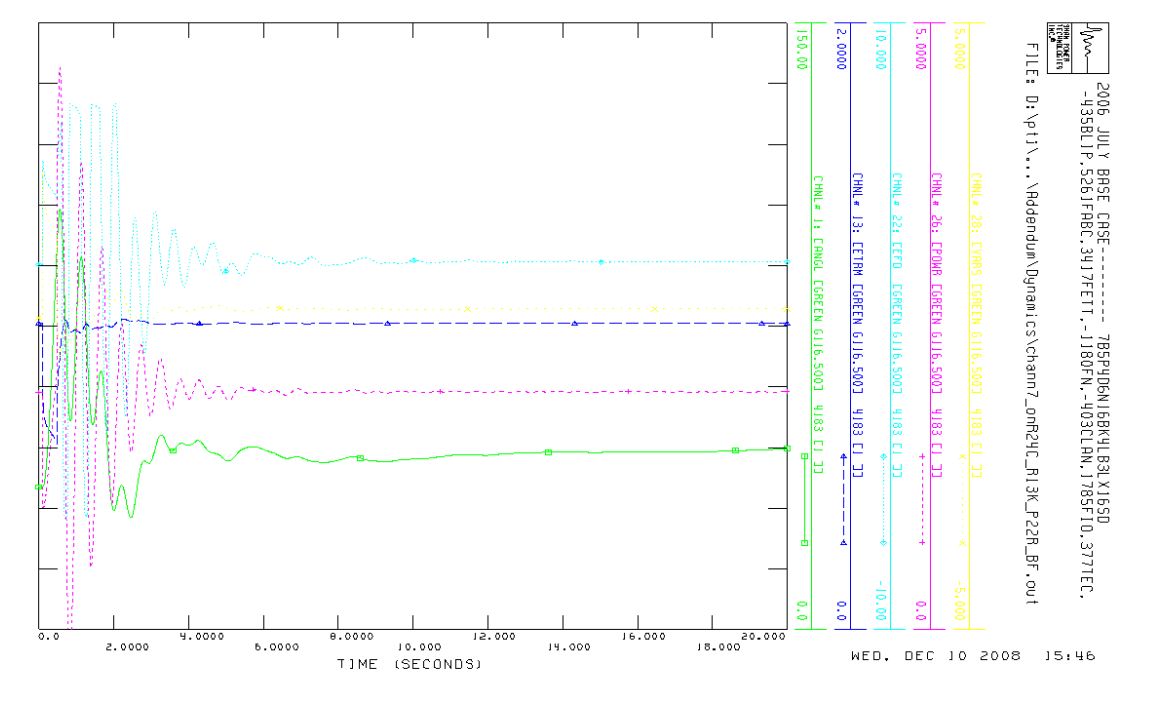

Figure F-20:
C.7 / R24C - R13K Phase-to-ground fault at Richview and Richview H2L22 Breaker Failure (P22R trip) - G2 response

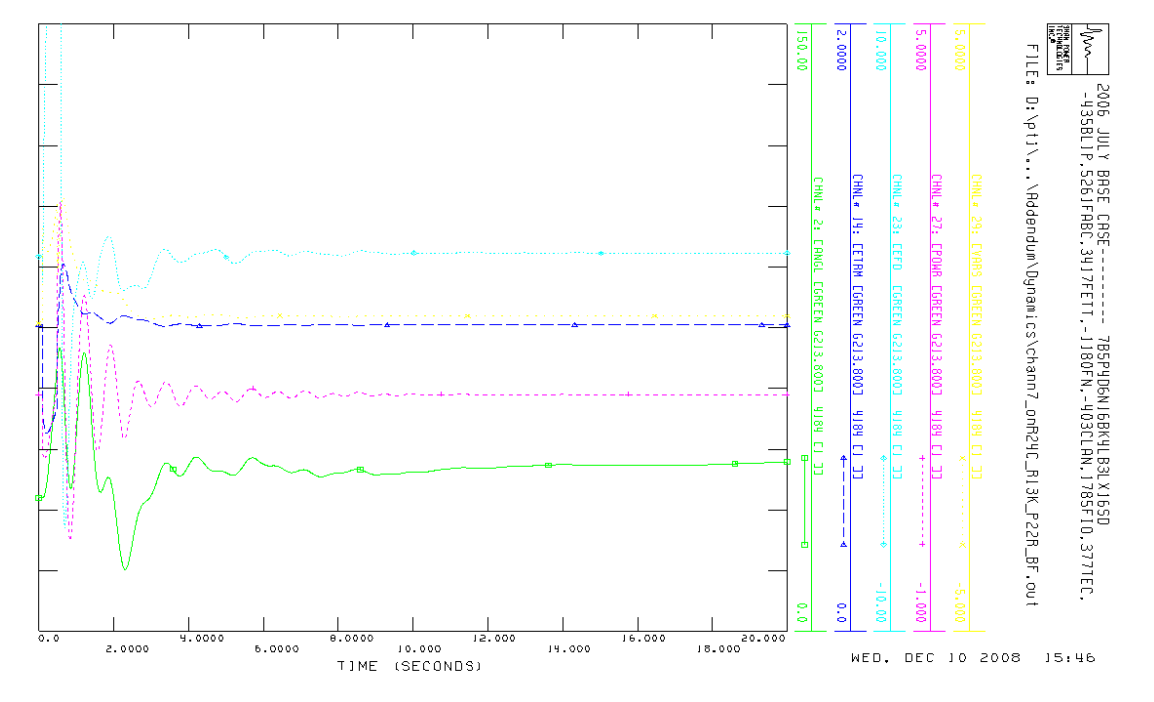

Figure F-21:
C.7 / R24C - R13K Phase-to-ground fault at Richview and Richview H2L22 Breaker Failure (P22R trip) - Major generator angles

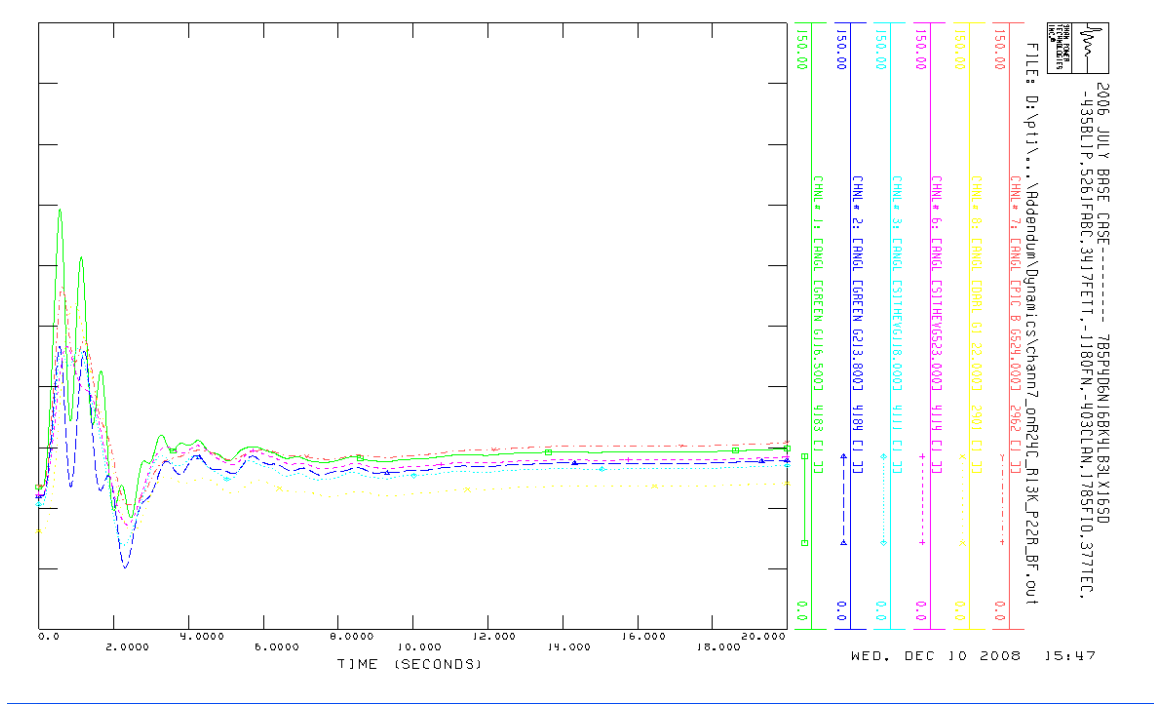

Figure 22:
C.8 / R24C - R1K Three-phase fault at Richview and R24C LEO at Richview (Richview L21L72 Breaker O/S) - G1 response

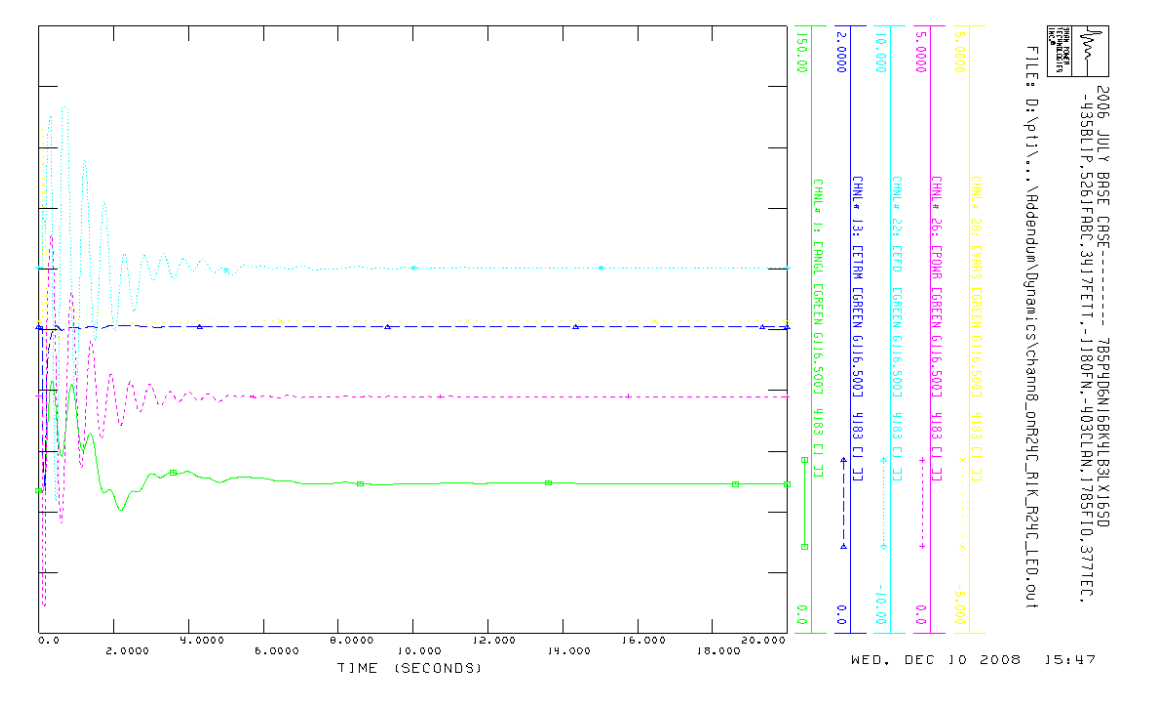

Figure 23:
C.8 / R24C - R1K Three-phase fault at Richview and R24C LEO at Richview (Richview L21L72 Breaker O/S) - G2 response

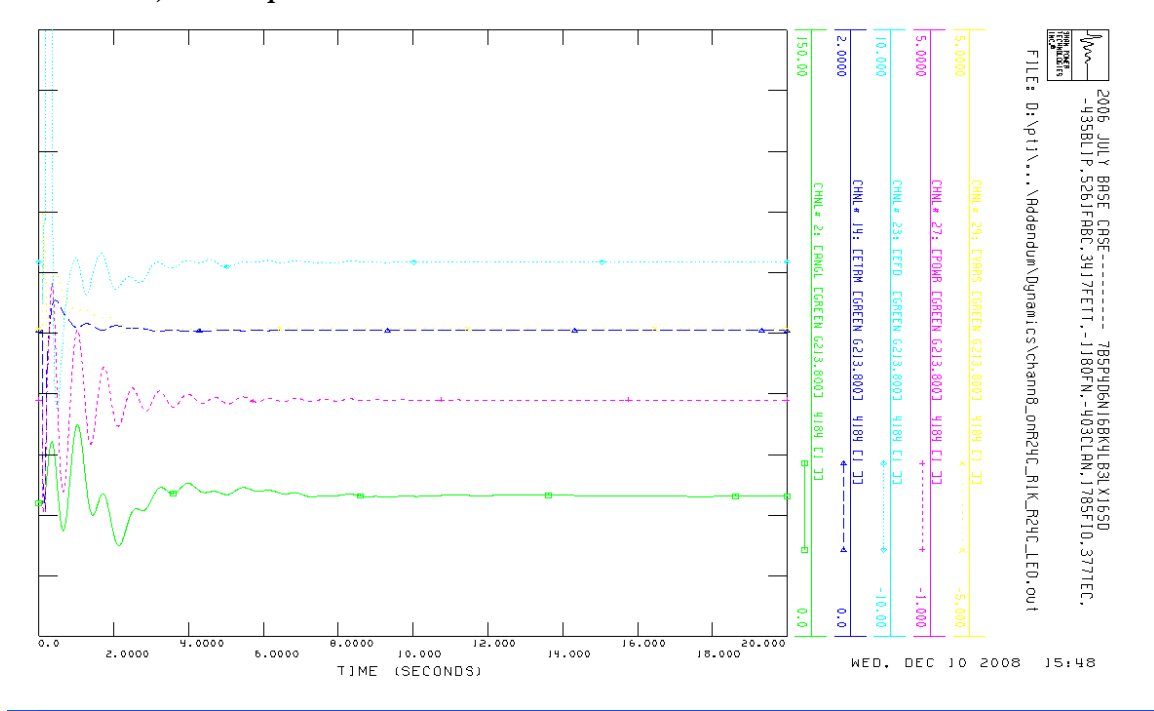

Figure 24:
C.8 / R24C - R1K Three-phase fault at Richview and R24C LEO at Richview (Richview L21L72 Breaker O/S) - Major generator angles

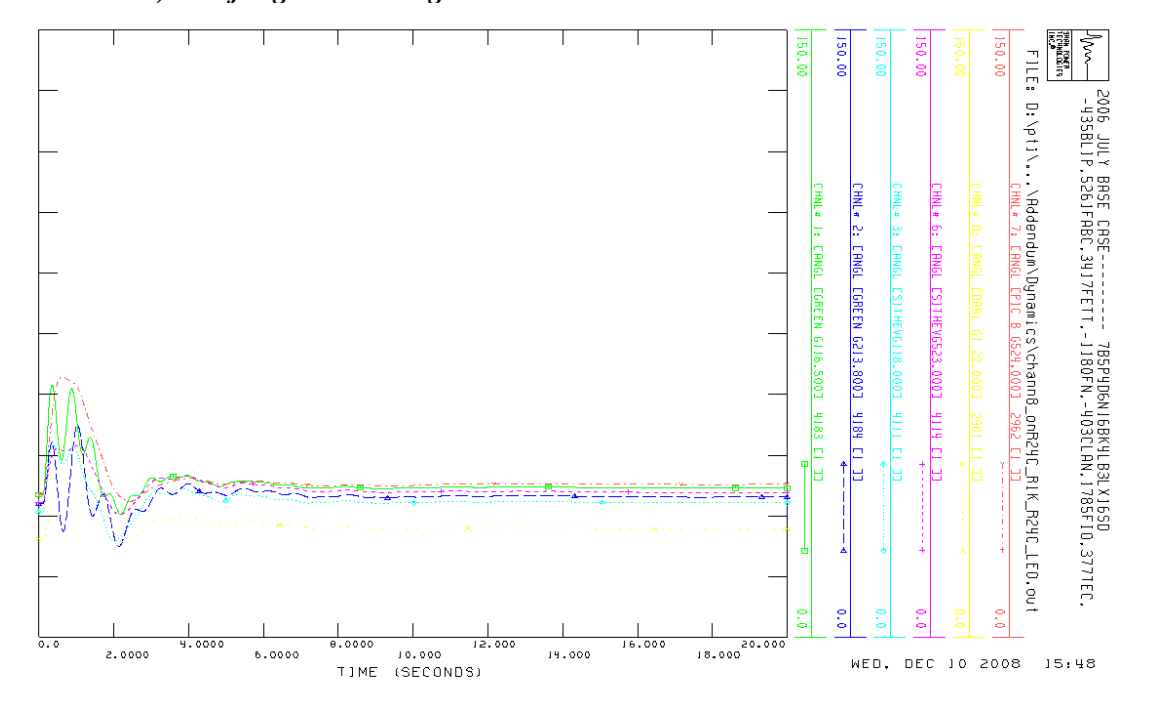

Figure F-25:
C.10 / R24C – R1K loss without a fault (small disturbance) - G1 response

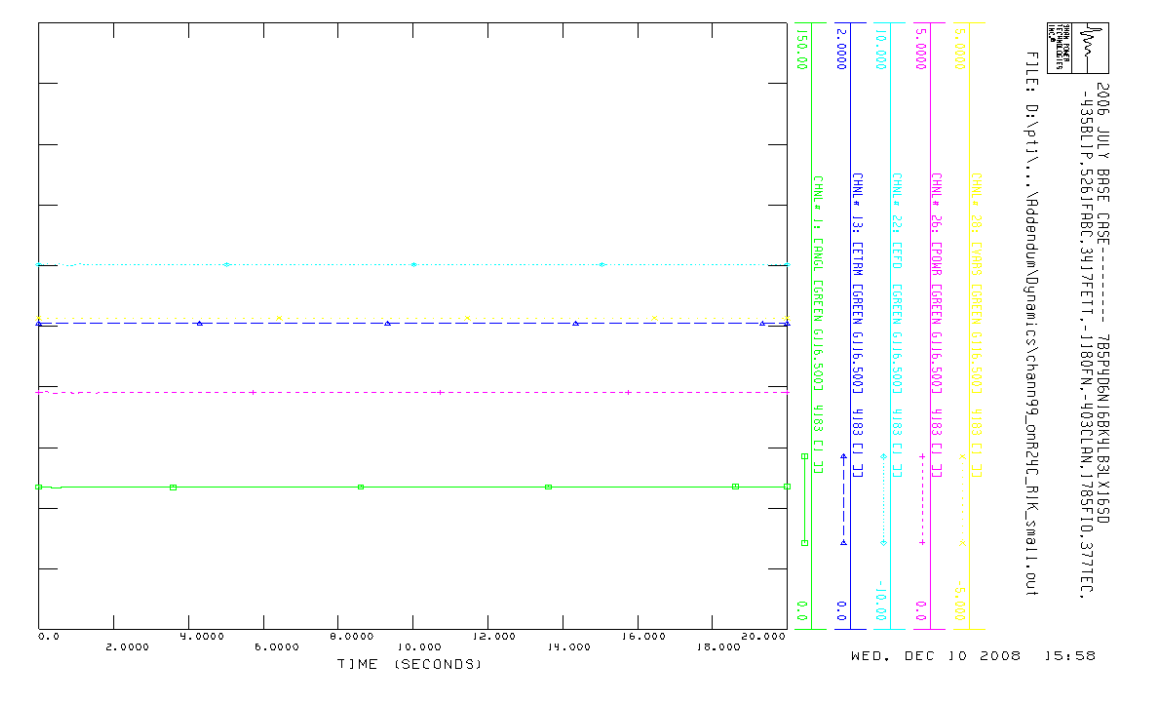

Figure F-26:
C.10 / R24C – R1K loss without a fault (small disturbance) - G2 response

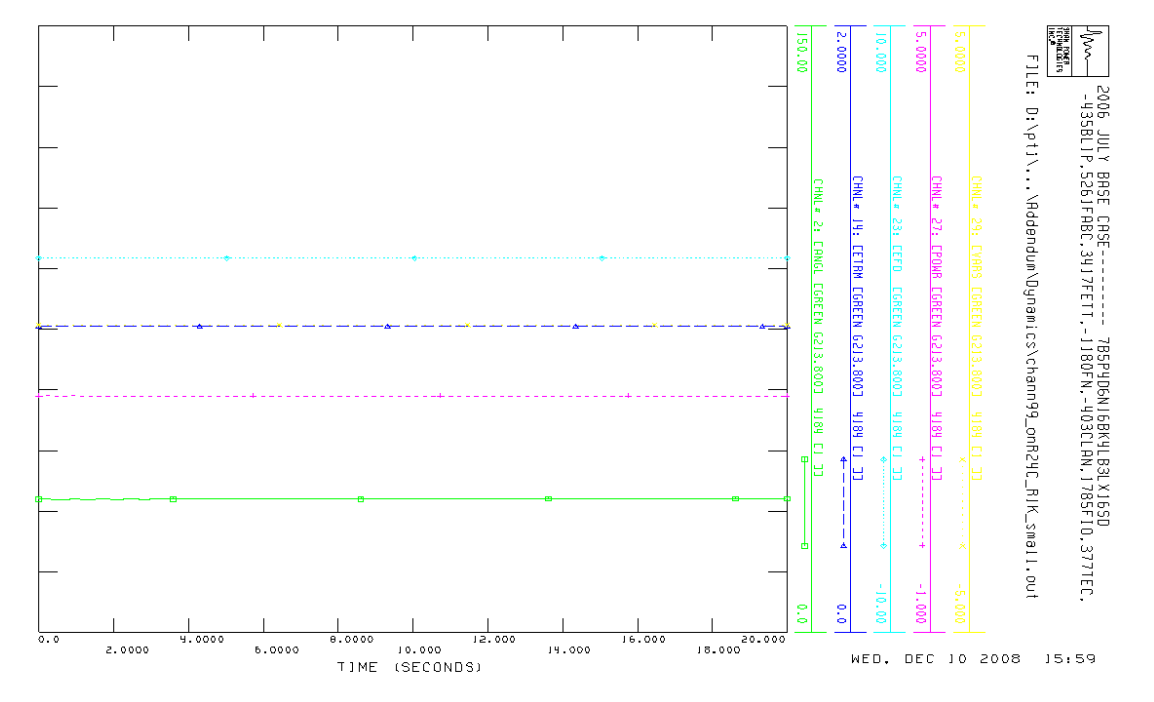
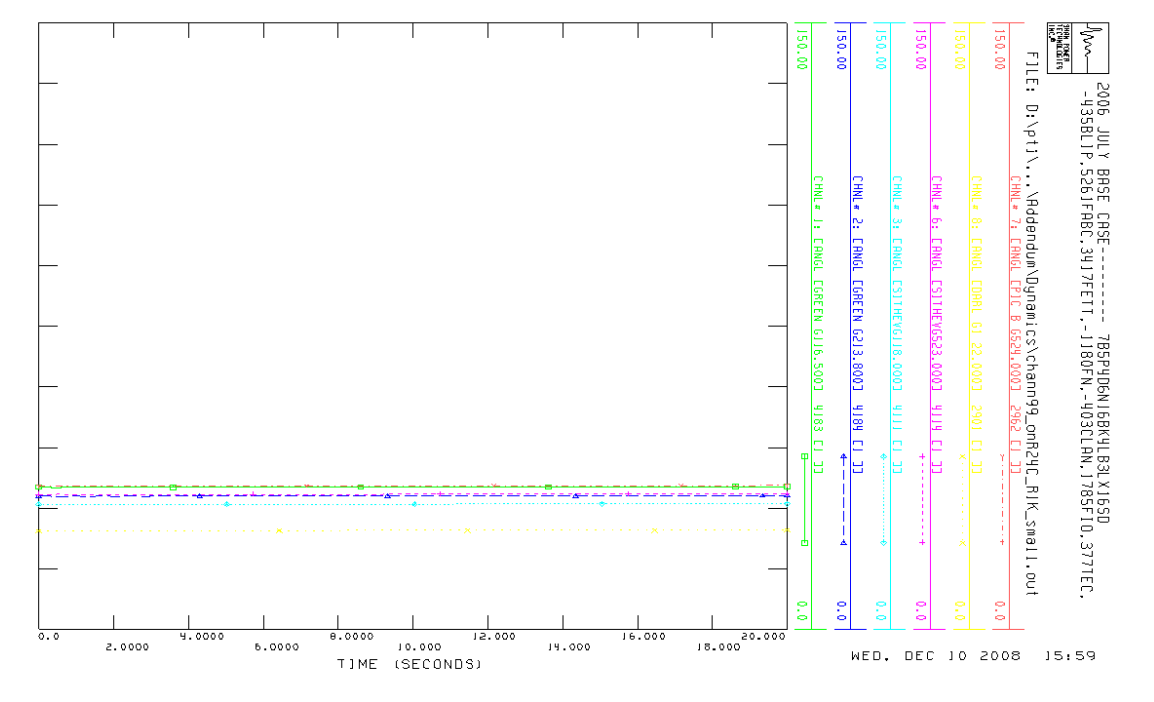

Figure F-27:
C.10 / R24C – RIK loss without a fault (small disturbance) - Major generator angles



Greenfield South GS connected to K23C

Figure F-28:
C.1 / K23C - R13K Three-phase fault at Richview TS - G1 response

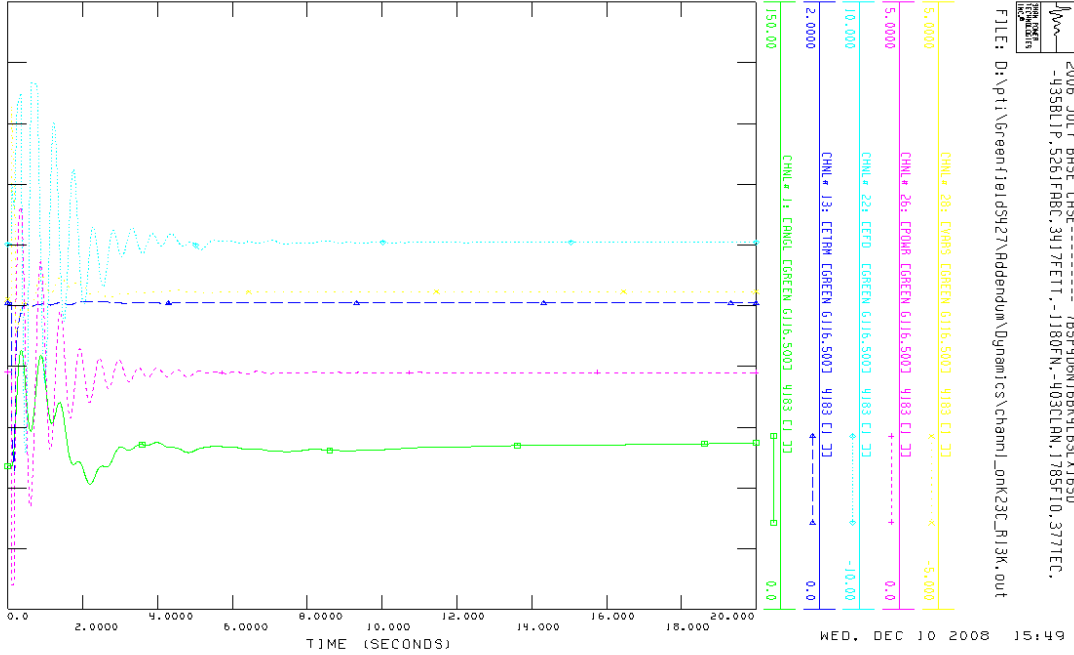

Figure F-29:
C.1 / K23C - R13K Three-phase fault at Richview TS - G2 response

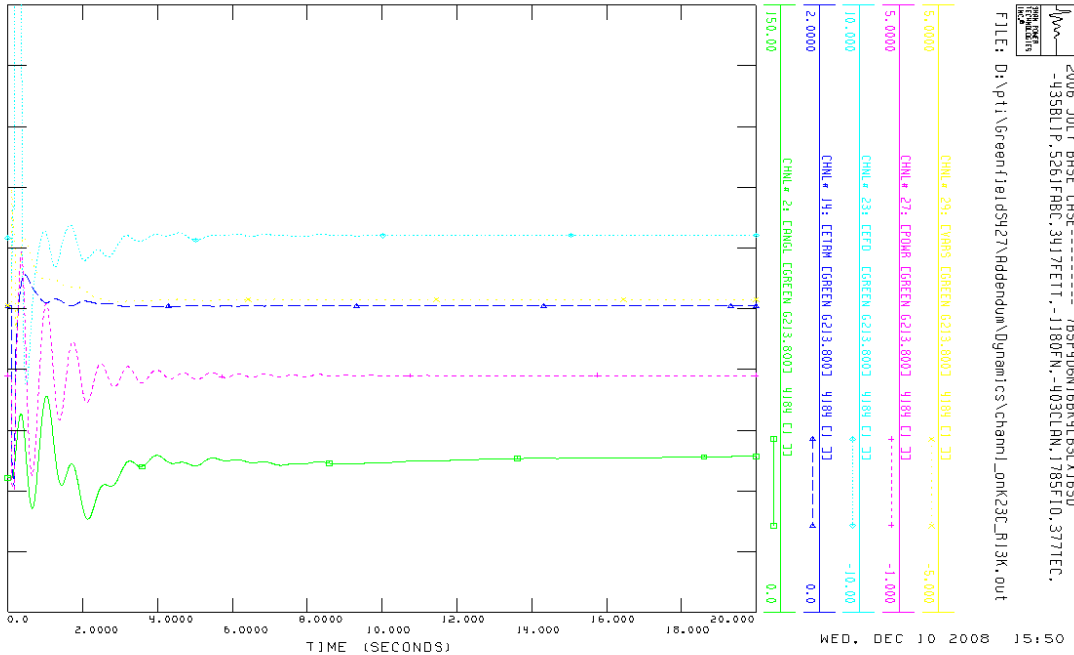

Figure F-30:
C.1 / K23C - R13K Three-phase fault at Richview TS - Major generator angles

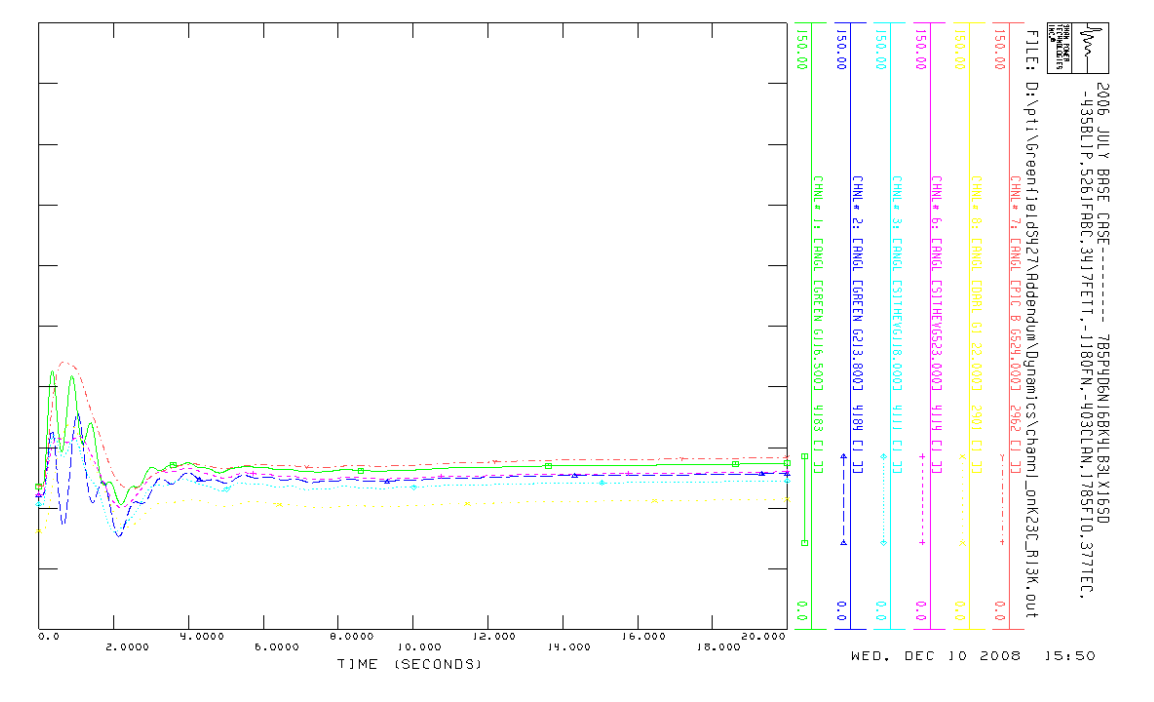

Figure F-31:
C.2 / K23C - R1K + R2K Phase-to-ground fault at Richview TS - G1 response

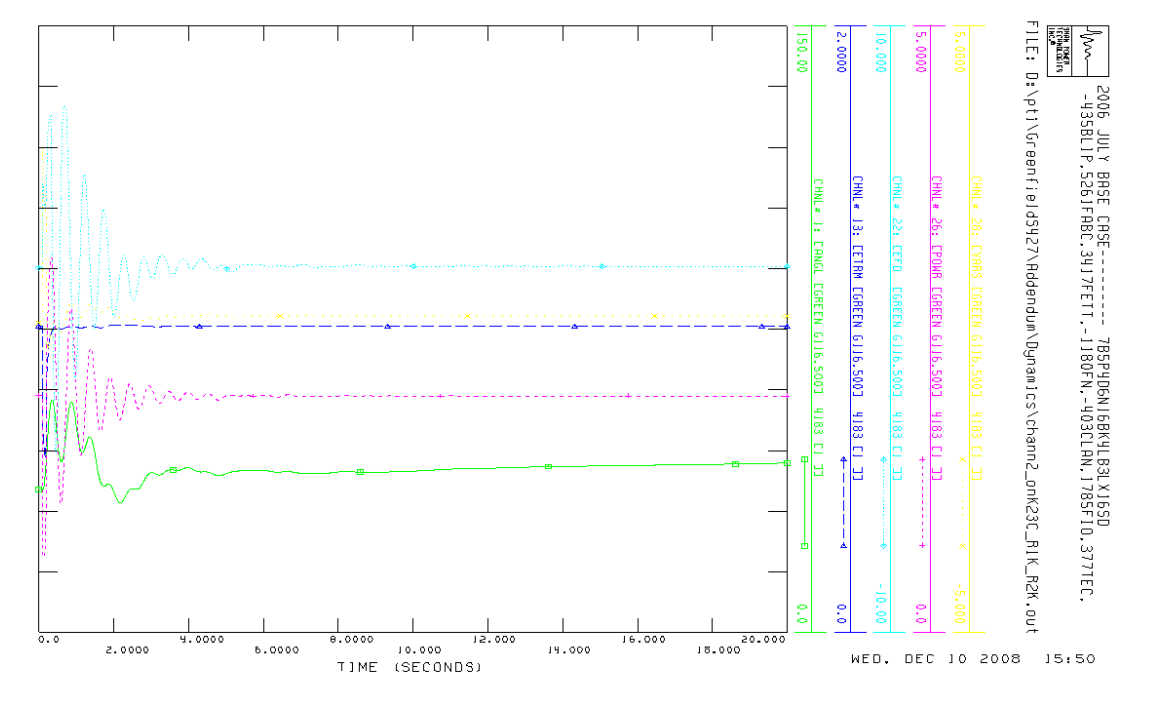

Figure F-32:
C.2/ K23C - R1K + R2K Phase-to-ground fault at Richview TS – G2 response

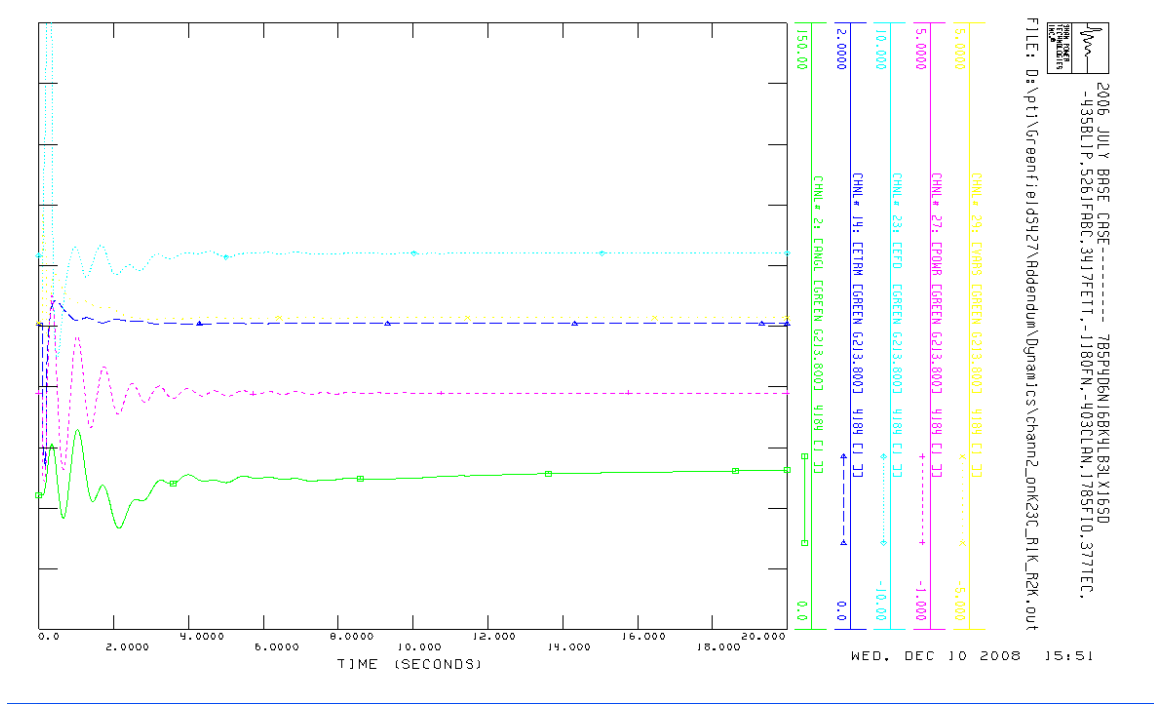

Figure F-33:
C.2 / K23C - R1K + R2K Phase-to-ground fault at Richview TS – Major generator angles

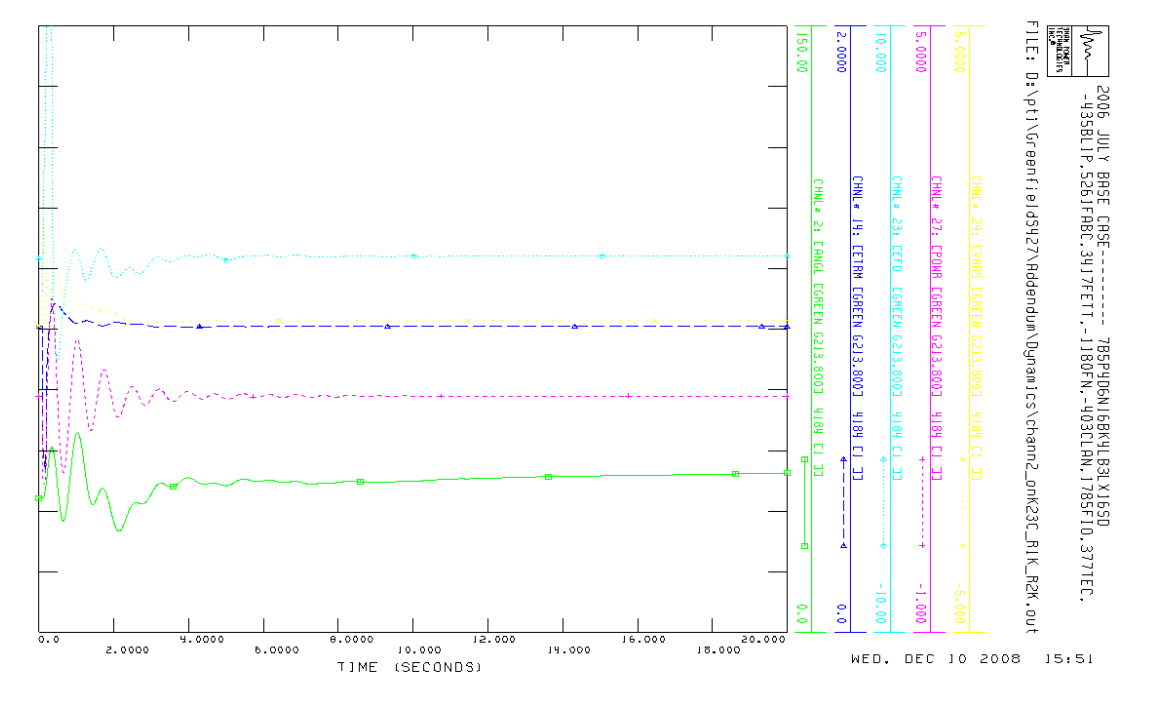

Figure F-34:
C.3 / K23C - K21C Three-phase fault at Cooksville - G1 response

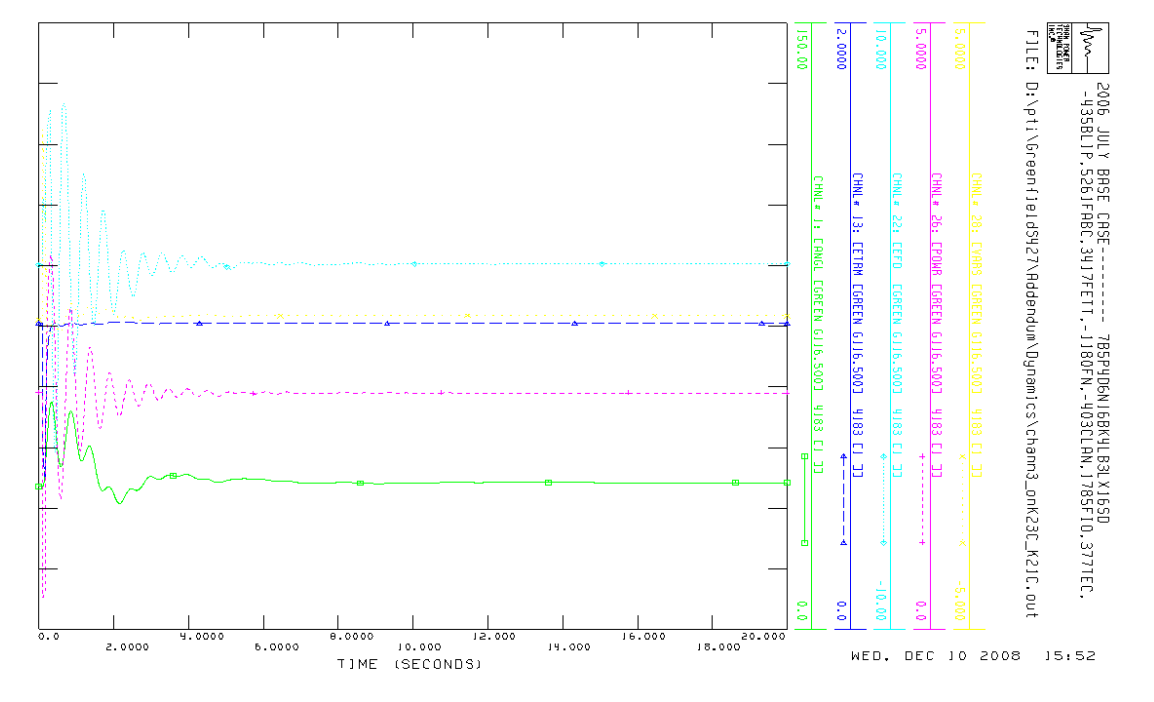

Figure F-35:
C.3 / K23C - K21C Three-phase fault at Cooksville - G2 response

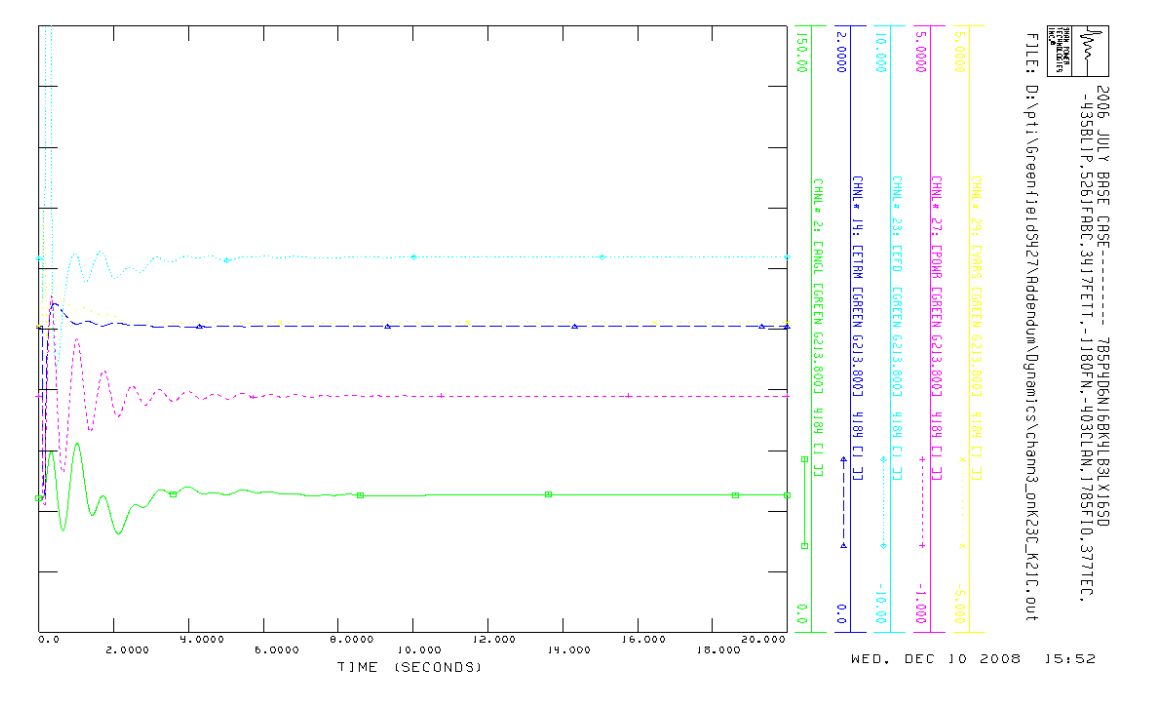

Figure F-36:
C.3 / K23C - K21C Three-phase fault at Cooksville - Major generator angles

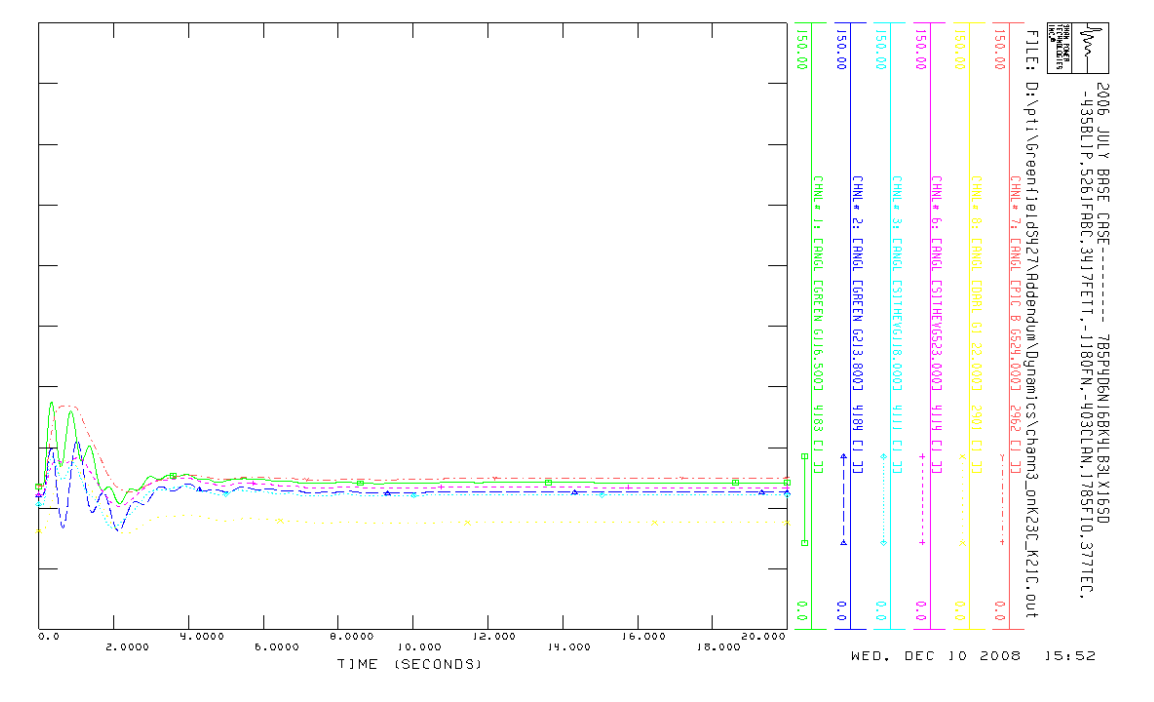

Figure F- 37:
C.6 / K23C - R1K Phase-to-ground fault at Richview and Richview A2L19 Breaker Failure (R19T trip) - G1 response

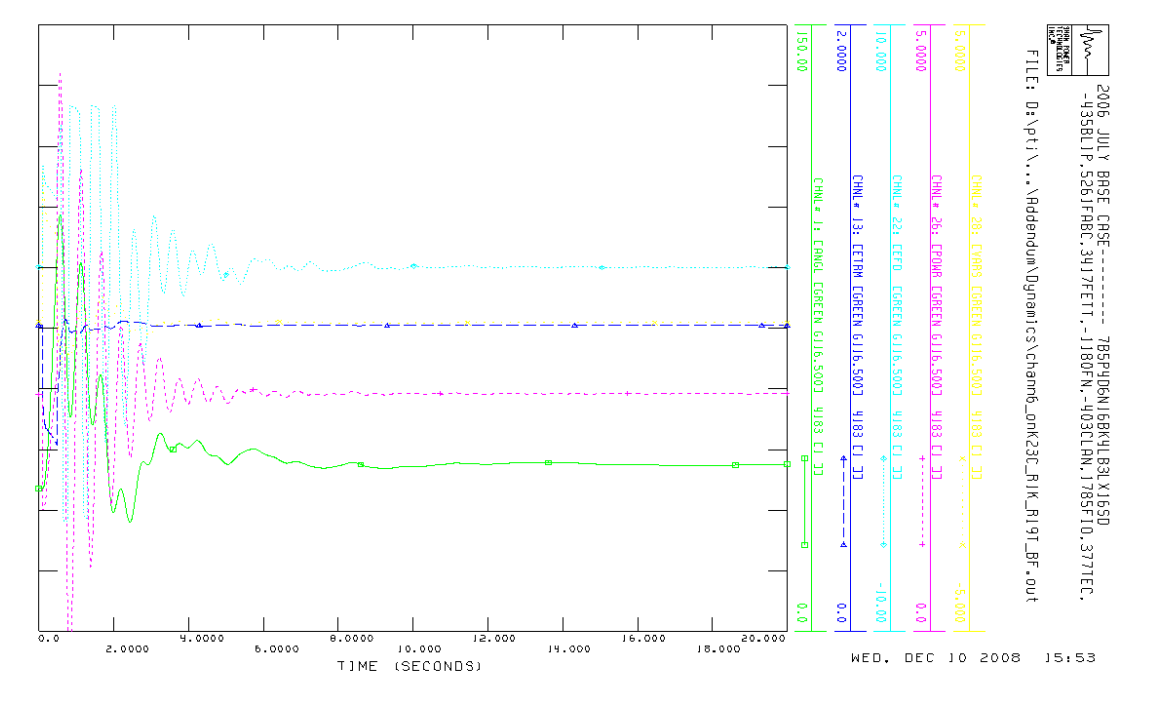

Figure F-38:
C.6 / K23C - R1K Phase-to-ground fault at Richview and Richview A2L19 Breaker Failure (R19T trip) - G2 response

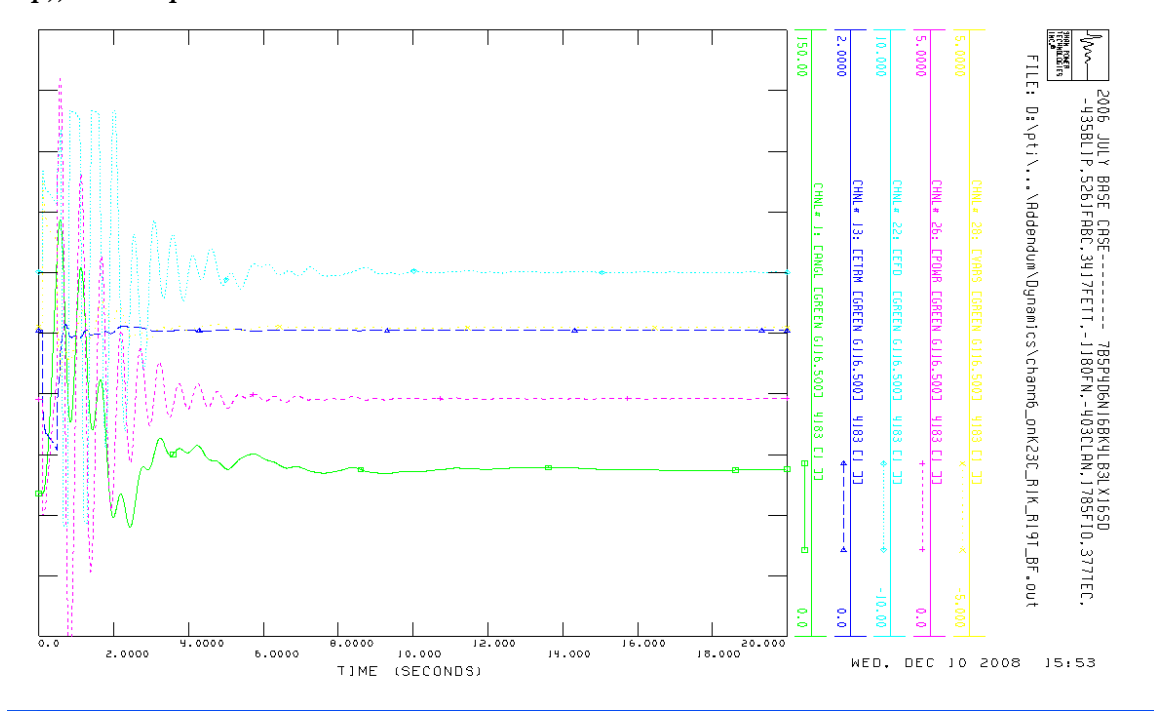

Figure F-39:
C.6 / K23C - R1K Phase-to-ground fault at Richview and Richview A2L19 Breaker Failure (R19T trip) - Major generator angles

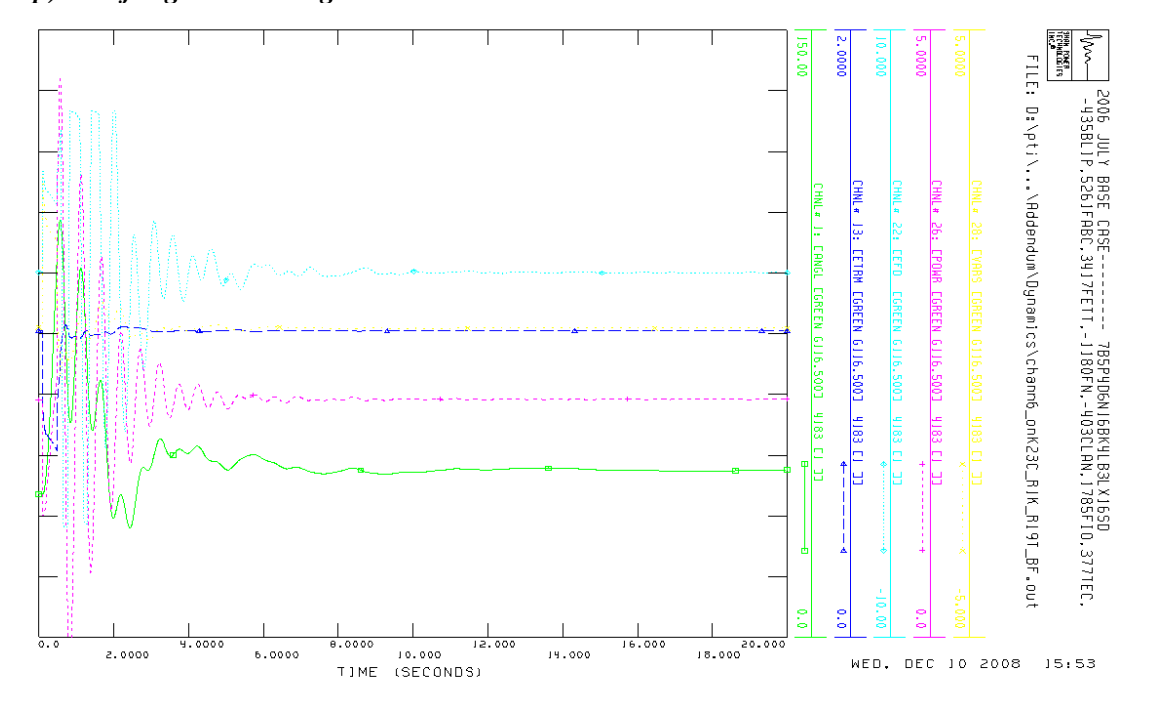

Figure F- 40:
C.7 / K23C - R13K Phase-to-ground fault at Richview and Richview H2L22 Breaker Failure (P22R trip) - G1 response

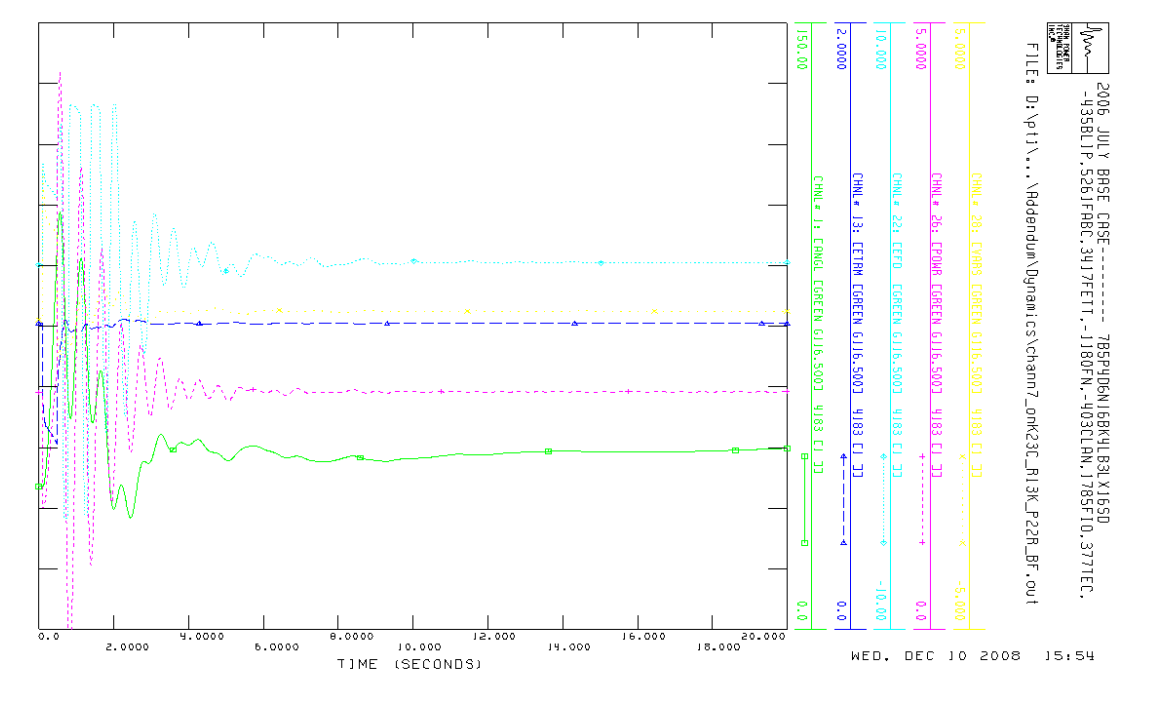

Figure F-41:
C.7 / K23C - R13K Phase-to-ground fault at Richview and Richview H2L22 Breaker Failure (P22R trip) - G2 response

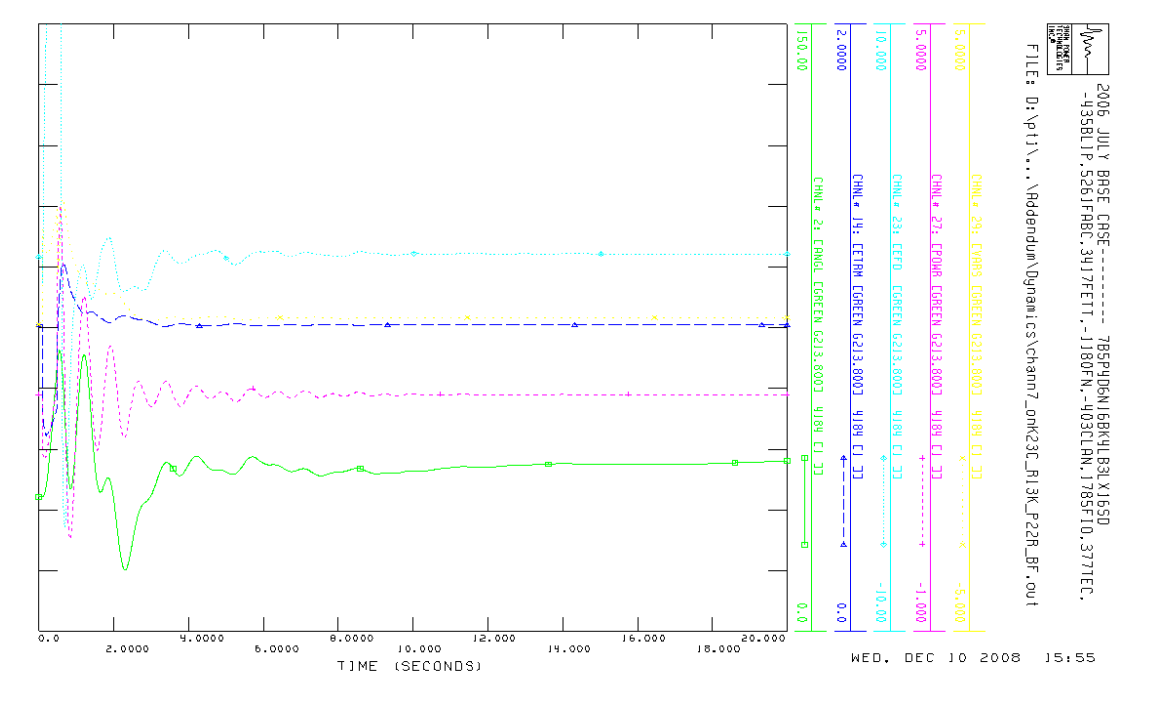

Figure F-42:
C.7 / K23C - R13K Phase-to-ground fault at Richview and Richview H2L22 Breaker Failure (P22R trip) - Major generator angles

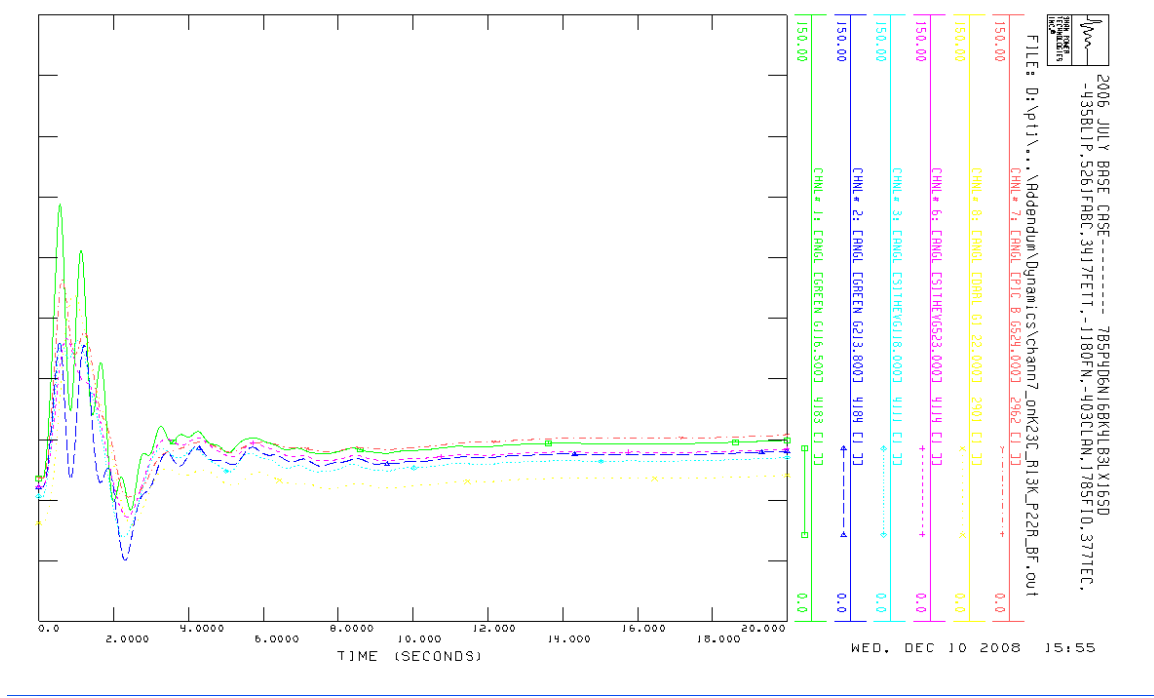

Figure 43:
C.9 / K23C - R1K Three-phase fault at Richview and K23C LEO at Manby E (Manby E H2L23 Breaker O/S) - G1 response

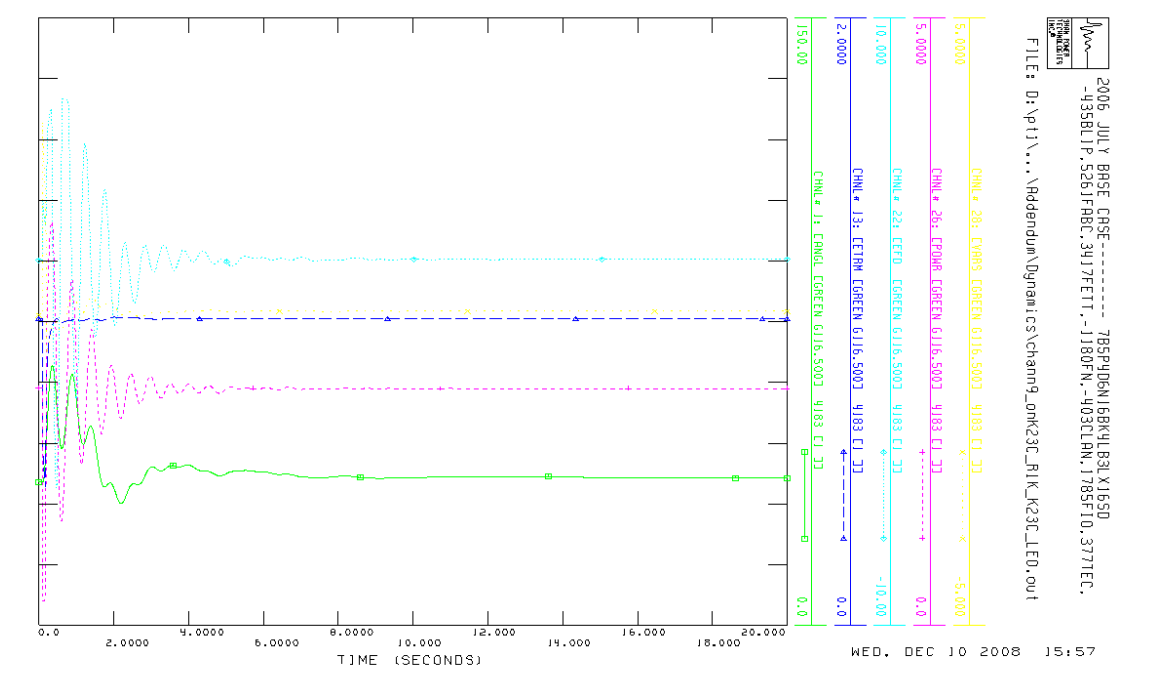

Figure 44:
C.9 / K23C – R1K Three-phase fault at Richview and K23C LEO at Manby E (Manby E H2L23 Breaker O/S) – G2 response

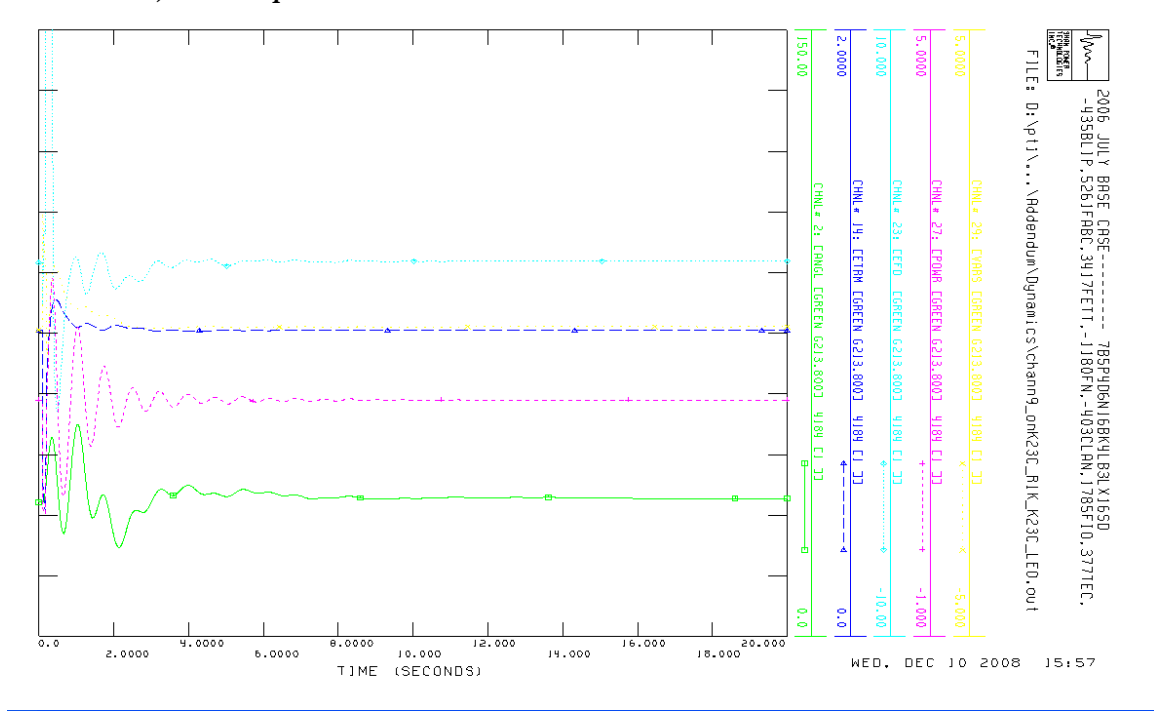

Figure 45:
C.9 / K23C – R1K Three-phase fault at Richview and K23C LEO at Manby E (Manby E H2L23 Breaker O/S) – Major generator angles

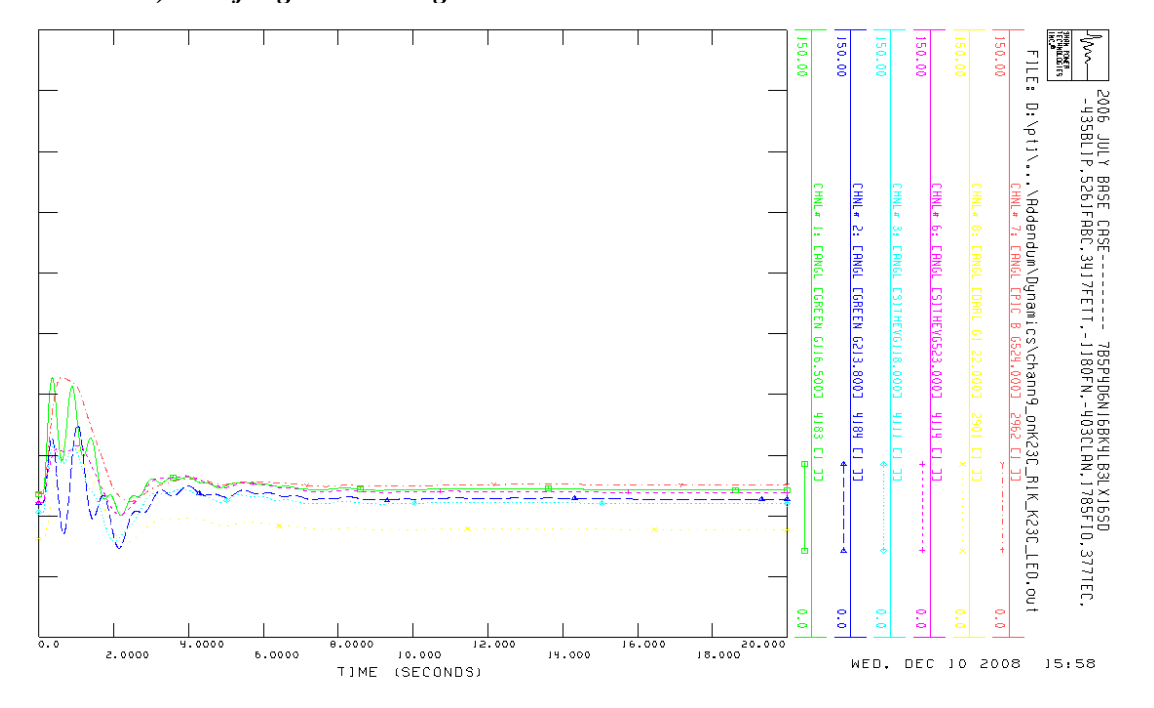

Figure F-46:
C.10 / K23C – R1K loss without a fault (small disturbance) - G1 response

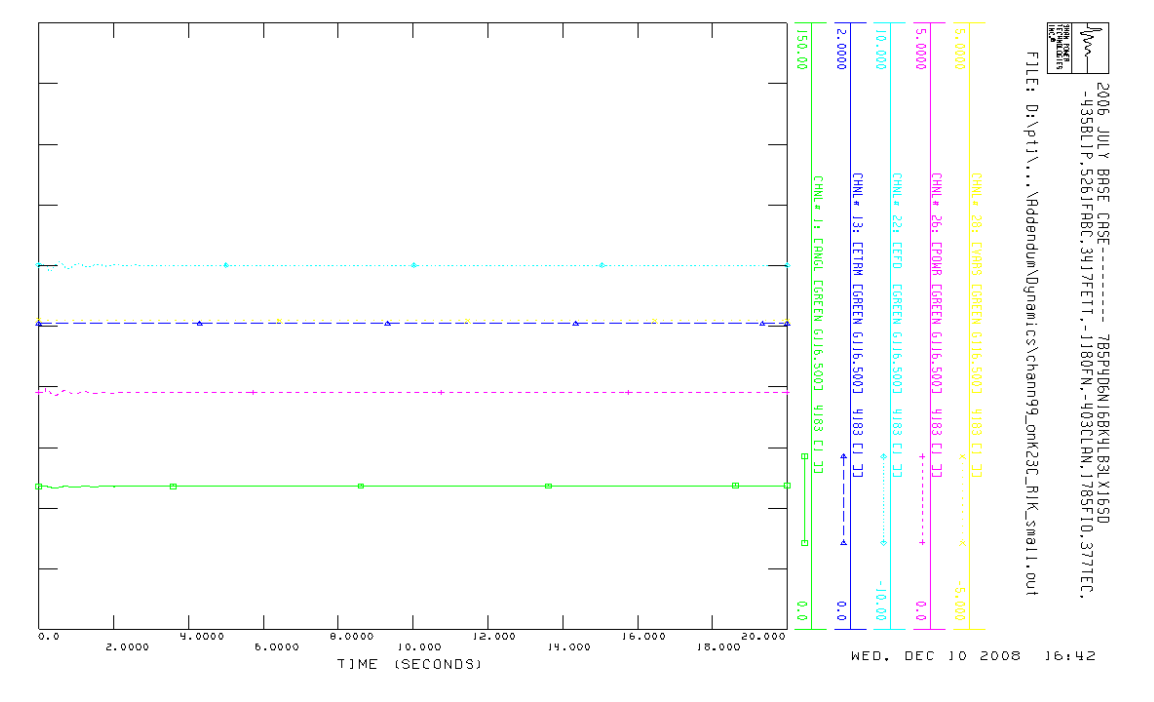

Figure F-47:
C.10 / K23C – R1K loss without a fault (small disturbance) - G2 response

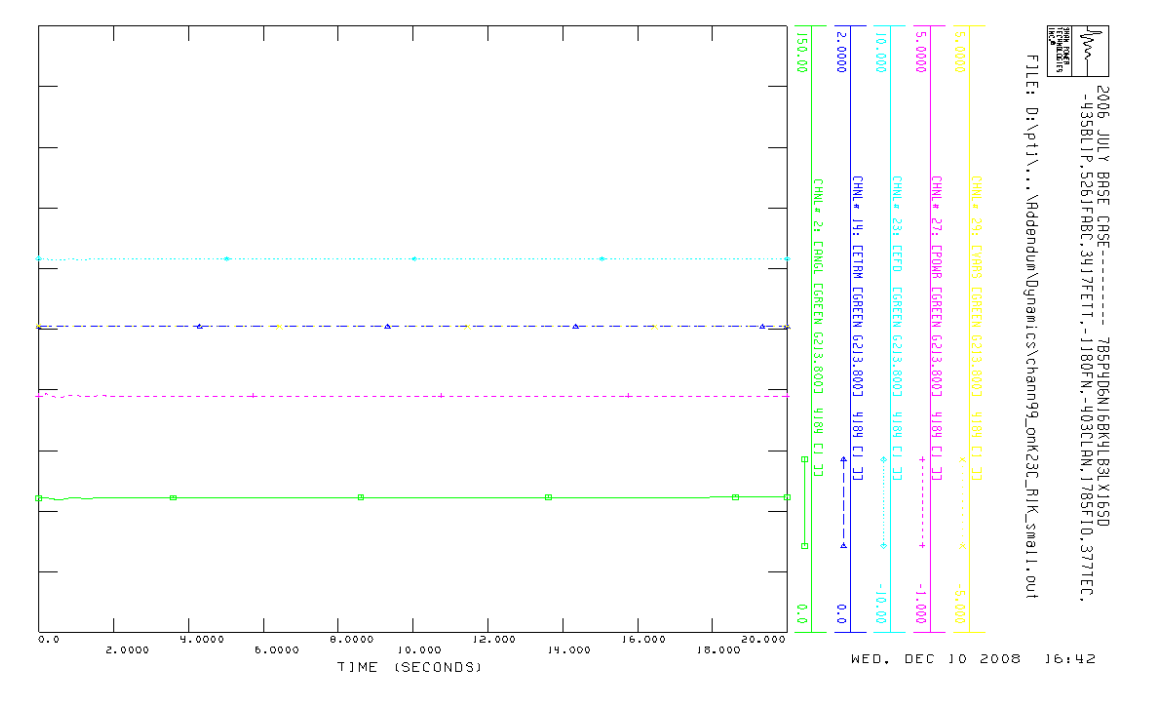
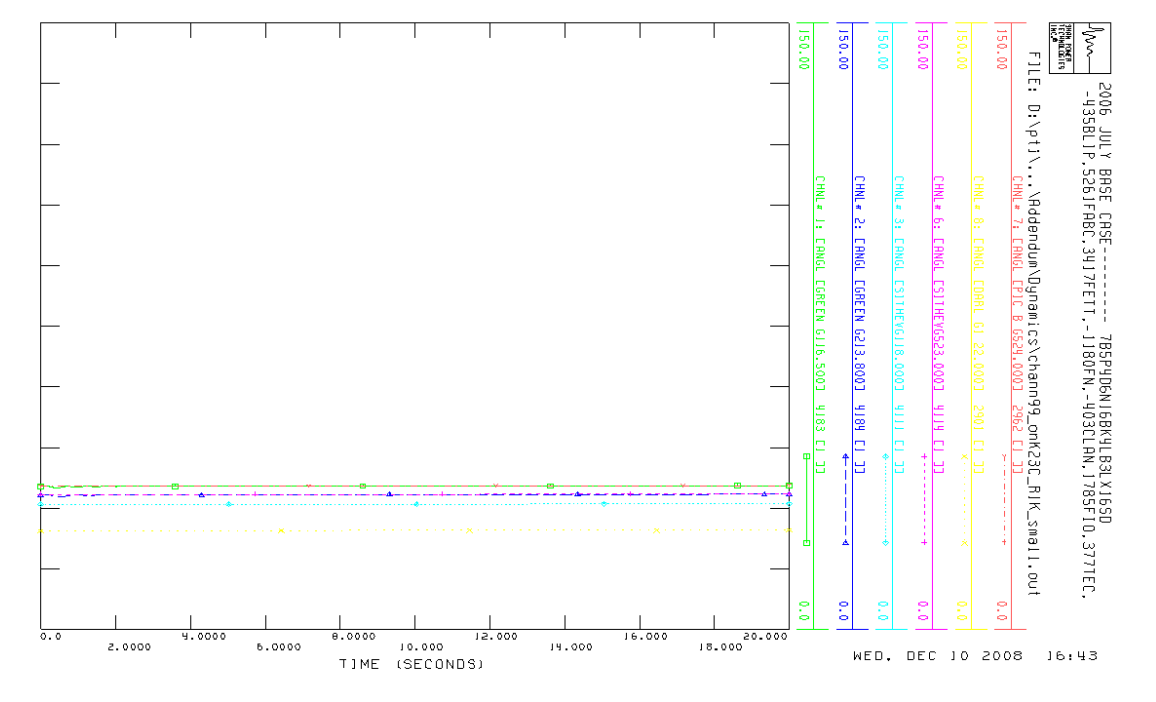

Figure F-48:
C.10 / K23C – RIK loss without a fault (small disturbance) - Major generator angles



-End of Section-

Appendix G

Single Line Diagrams

Figure G-1: Single Line Diagram – Greenfield South O/S

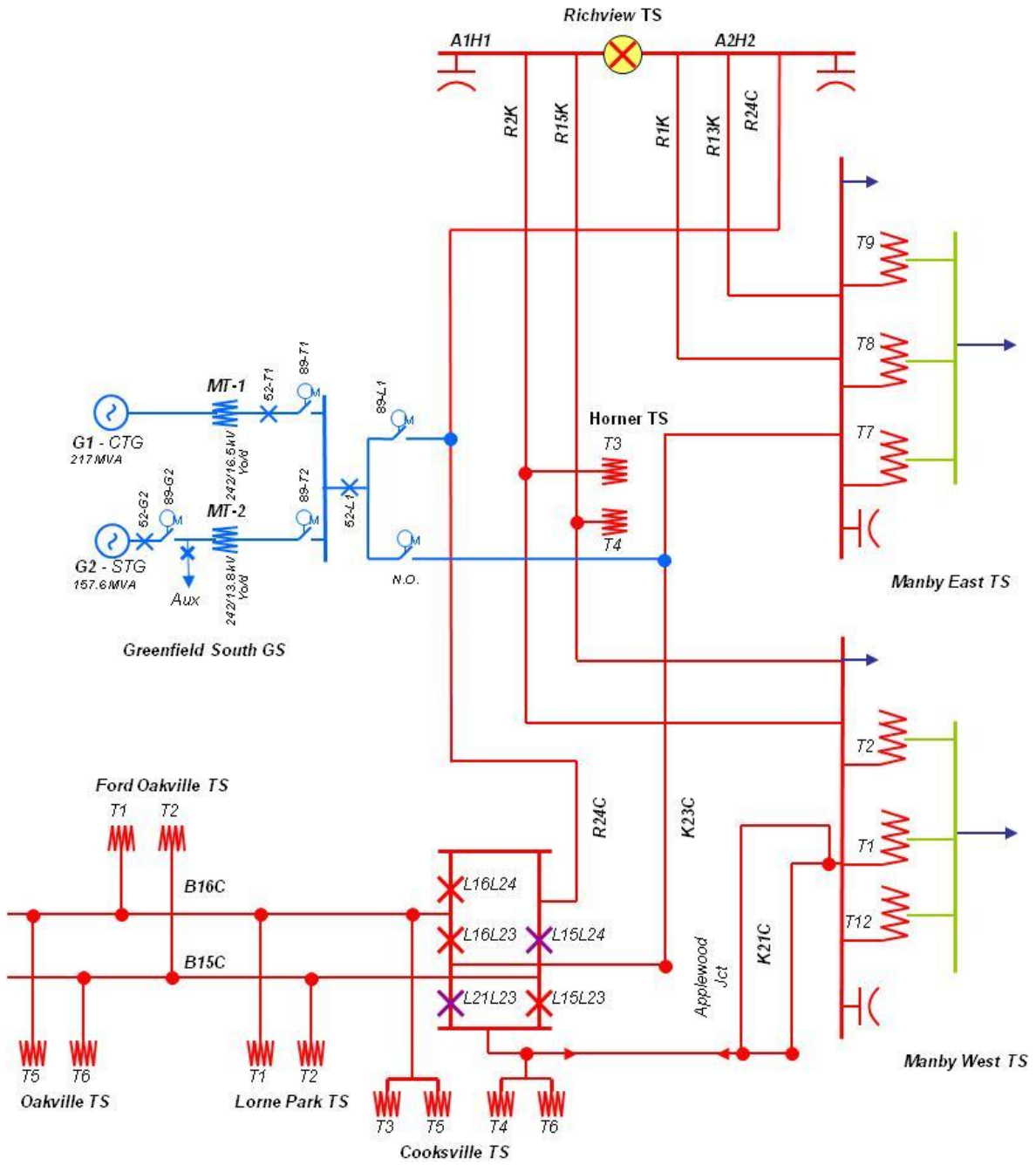

Proposed Configuration

– End of Section –

– End of Document –