



CONNECTION ASSESSMENT & APPROVAL PROCESS

Connection Assessment Report for Elgin TS New A1/H2 Bus-tie Cable

Connection Applicant: Hydro One Networks Inc.

CAA ID 2002-EX044

Final Report

Prepared by
Long Term Forecasts & Assessments Department &
Consistent Information Set Department

June 18, 2002

1.0 Project Description

Hydro One Network Inc. has submitted a connection assessment application for the installation a bus-tie underground cable at Elgin TS between A1 and H2 115 kV buses. The purpose of this proposal is to allow the continued supply of all four Elgin TS transformers in the event of a permanent fault associated with either HL4 or HL3 underground cables to Newton TS, until restoration of the faulty cable is complete.

A single line diagram of the proposed project is shown in Figure 1. The new cable is to be connected between the jaw side of the renamed 28A1-H2 switch and to the H2 bus.

Elgin TS supplies the Hamilton downtown load and comprises of two DESN units, each consisting of two 115/13.8 kV transformers rated 2x45/75 MVA (T1&T2) and 2x20/33.3 MVA (T3&T4) respectively. Normally, the Elgin TS load is supplied from Newton TS with switch 28HL3-48 open. The 115 kV underground cable HL4 to Stirton TS is out of service indefinitely and Hydro One Networks Inc. is not have planning to bring it back to service.

2.0 Assessment

The IMO assessed the effect of the proposed bus-tie underground cable on the reliability and the load meeting capability of the existing facilities.

Under normal operating conditions with all available transmission elements in service when Elgin TS load is supplied from Newton TS, the new bus-tie cable is operated open. Consequently, Elgin TS transformers T1 and T3 would be supplied from HL4 underground cable and T2 and T4 will be supplied from HL3 underground cable.

The proposed bus-tie will be used only in case of outage to one of the 115 kV cables HL3 or HL4 into Newton TS. If a permanent fault occurs on HL3 between Elgin TS and Newton TS then, after the isolation of the fault, the supply to T2 and T4 can be restored by closing 28A1-H2 disconnect switch. Alternatively, if a permanent fault occurs on HL4 between Elgin TS and Newton TS then, after the isolation of the fault, the supply to T1 and T3 can be restored by closing 28A1-H2 disconnect switch. This way, all four transformers at Elgin TS will continue to be supplied from Newton TS via the remaining 115 kV underground cable.

The summer continuous rating of the underground cables is as follows:

- HL3 with HL4 out of service – 1050 A or 214 MVA
- HL4 with HL3 out of service – 1040 A or 212 MVA

Station loading records that were obtained from the Hydro One data indicate that the Elgin TS load non-coincident 2001 peak was about 103 MVA. This level of peak load does not raise any concerns with respect to capability of the local transmission system to supply the peak load in the area.

HL3 or HL4 Thermal Loading

Historical load records provided by Hydro One indicate that summer peak load at Elgin TS is well under the continuous rating of one of the 115 kV cables supplying the station. In the event of outage to either HL3 or HL4 the remaining cable will be loaded below its continuous rating.

It should be noted that, in the unlikely event that both cables between Elgin TS and Newton fail, then the Elgin TS load must be transferred to Beach TS.

Elgin TS Transformers

The load capability of a DESN station is defined as the maximum load that one transformer can carry for a predefined period of time. This value is usually computed using specific transformer data and daily load curves, and temperature data specific to the transformer location.

Because Elgin TS comprises of two DESN stations and assuming that all the load can be transferred between the two DESNs', the load capability of the station is assumed to be equivalent to the 10 day limited time rating of the lowest rated three transformers. Hence, Elgin TS station load capability is 178.2 MVA ($2 \times 44.7 + 88.8$).

In 2001, the station load coincident with system peak of 103 MVA was well under the load capability of the station.

3.0 Conclusions and Recommendations

The proposed bus-tie underground cable is unlikely to have any adverse impact on the reliability of the IMO-controlled grid or the load meeting capability of the existing facilities.

The IMO has concluded that the project allows for increased flexibility in connectivity which results in an improvement to the reliability of supply to the Elgin TS loads.

4.0 Notification of Approval

It is thus recommended that notification of approval be granted for the installation of bus-tie underground cable connecting A1 and H2 115 kV buses at Elgin TS.

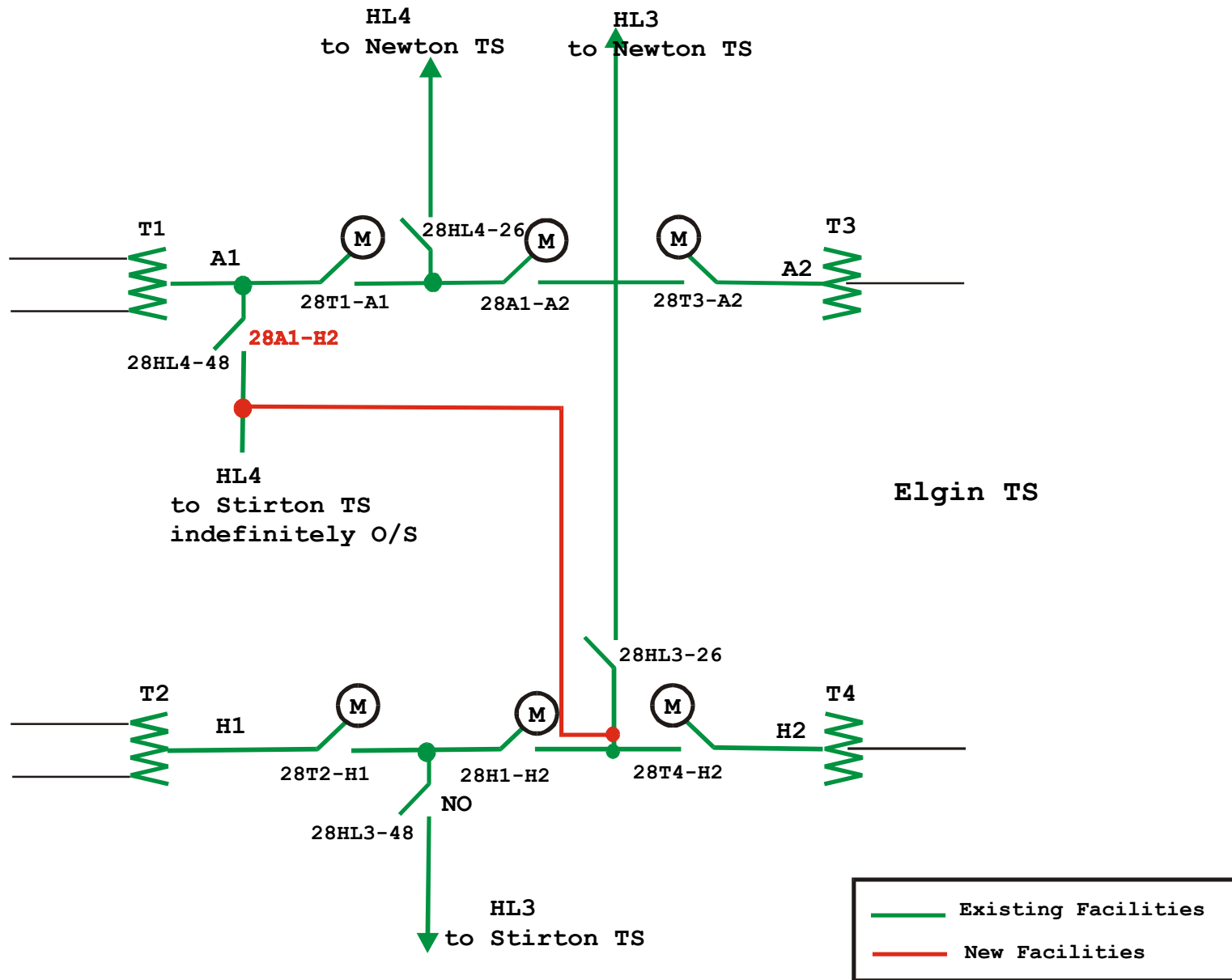

Figure 1. Elgin TS Proposed Bus-tie Cable Project