

Independent Electricity
System Operator
Station A, Box 4474
Toronto, Ontario M5W 4E5
t 905 855 6100
www.ieso.ca

CONNECTION ASSESSMENT & APPROVAL PROCESS

PRELIMINARY ASSESSMENT REPORT: 3rd Addendum

*For the Proposed 600MW Portlands Energy Centre Project
by Ontario Power Generation Inc. at Hearn GS.*

CAA ID No. 2001-040

Transmission Assessments & Performance Department

FINAL Version

Date: 12th October 2007

Preliminary Assessment Report: 3rd Addendum

For the Proposed Development of the 600MW Portland Energy Centre Project

Acknowledgement

The IESO wishes to acknowledge the assistance of Hydro One in completing this assessment.

Disclaimers

IESO

This report has been prepared solely for the purpose of assessing whether the connection applicant's proposed connection with the IESO-controlled grid would have an adverse impact on the reliability of the integrated power system and whether the IESO should issue a notice of approval or disapproval of the proposed connection under Chapter 4, section 6 of the Market Rules.

Approval of the proposed connection is based on information provided to the IESO by the Hydro One Networks Inc. at the time the assessment was carried out. The IESO assumes no responsibility for the accuracy or completeness of such information, including the results of studies carried out by the transmitter at the request of the IESO.

Furthermore, the connection approval is subject to further consideration due to changes to this information, or to additional information that may become available after the approval has been granted. Approval of the proposed connection means that there are no significant reliability issues or concerns that would prevent connection of the proposed facility to the IESO-controlled grid. However, connection approval does not ensure that a project will meet all connection requirements. In addition, further issues or concerns may be identified by the transmitter during the detailed design phase that may require changes to equipment characteristics and/or configuration to ensure compliance with physical or equipment limitations, or with the Transmission System Code, before connection can be made.

This report has not been prepared for any other purpose and should not be used or relied upon by any person for another purpose. This report has been prepared solely for use by the connection applicant and the IESO in accordance with Chapter 4, section 6 of the Market Rules. The IESO assumes no responsibility to any third party for any use, which it makes of this report. Any liability which the IESO may have to the connection applicant in respect of this report is governed by Chapter 1, section 13 of the Market Rules. In the event that the IESO provides a draft of this report to the connection applicant, you must be aware that the IESO may revise drafts of this report at any time in its sole discretion without notice to you. Although the IESO will use its best efforts to advise you of any such changes, it is the responsibility of the connection applicant to ensure that the most recent version of this report is being used.

Hydro One

Special Notes and Limitations of Study Results

The results reported in this system impact assessment are based on the information available to Hydro One, at the time of the study, suitable for a system impact assessment of a new transmission facility.

ONTARIO POWER GENERATION Inc.: PORTLANDS ENERGY CENTRE

3rd Addendum to the Preliminary Assessment Report for the Proposed 600MW Development at Hearn GS

Summary

The conclusions drawn from the analysis that was performed for this assessment, together with the associated recommendations, can be summarised, as follows:

- i. The generating units as now proposed, together with the system changes that are expected to be implemented during the next five years, will result in fault levels at both Hearn SS and Leaside TS that will be substantially higher than those identified in Addendum No. 2, even with reactors installed in the neutral connection of each of the generator step-up transformers at the Portlands Energy Centre. For this analysis, the 230kV & 115kV busbars at Leaside TS, together with the 115kV busbar at Hearn SS were all assumed to be operated open.

To ensure that the fault interrupting capability of the existing breakers at both Hearn SS and Leaside TS is not exceeded, it is therefore recommended that either of the following measures should be implemented to limit the fault levels:

- Defer the interchange of the 230kV circuits C3L & C17L until a permanent solution to the fault level issue can be implemented.
 - Temporarily remove one of the auto-transformers associated with the western half of the 115kV busbar at Leaside TS from service, pre-contingency, whenever high levels of generation capacity are dispatched.
- ii. To limit the fault currents for line-to-ground faults, reactors rated at 5.3 millihenries (approximately 2 ohms) are required to be installed in the neutral connection of each of the generator step-up transformers at the Portlands Energy Centre.
 - iii. To avoid restrictions on the dispatch of the Portlands Energy Centre, particularly during periods when transmission elements are out-of-service, a Special Protection System is required to allow the units to be selected for automatic run-back or rejection in response to a series of system contingencies.
 - iv. The settings proposed for the exciters on all three generating units have been shown to be inadequate to satisfy the requirements specified Market Rules. The IESO therefore requires revised settings to be implemented that will ensure compliance.
 - v. Similarly, since the settings proposed for the governors on the gas-turbines units have been shown to result in an unacceptable performance, the IESO requires revised governor settings to be implemented for the gas-turbine units.

The response recorded for the governor on the steam-turbine unit, with the settings that were submitted, would be acceptable.

- vi. The responses obtained for a first contingency involving one of the 115kV circuits between Leaside TS and Hearn SS connected to either the eastern or western halves of the busbar have shown that the units would remain transiently stable.

Customer Impact Assessment

Since it is considered to be outside the scope of this assessment, it is expected that Hydro One, as part of their Customer Impact Assessment for this Project, will review the existing capacitor bank installations at Hearn to confirm that it will not be necessary to impose limitations on their switching operations whenever the generating units at the Portlands Energy Centre are dispatched.

Notification of Approval of the Connection Proposal

Since the higher than acceptable fault levels at Leaside TS are considered to be a system issue that will need to be addressed through measures that Hydro One will need to implement, no action other than the installation of the neutral reactors as detailed below, will be required by the Portlands Energy Centre.

Subject to all of the other requirements that have been detailed below, being satisfied, it is therefore recommended that a Notification of Approval to Connect be issued for the Portlands Energy Centre:

- The installation of 5.3 millihenry reactors in the neutral connection of each of the generator step-up transformers at the Portlands Energy Centre.
- The installation of the Hearn Generation Run-back/Rejection & Cross-tripping Scheme.
- The implementation of revised settings on the exciters of the gas-turbine & steam-turbine units to ensure their performance satisfies the requirements of the Market Rules.
- The implementation of revised settings on the governors of the gas-turbine units so that their performance satisfies the requirements of the Market Rules.
- The provision of commissioning results confirming both the accuracy of the data used in this assessment and that the settings as implemented will meet all of the requirements of the Market Rules.

1. Introduction

Revised data have recently been provided to the IESO by Portlands Energy Centre LP. for the generating units that they are presently installing on the site of the former Hearn Generating Station.

This 3rd Addendum summarises the results of the IESO's assessment of the effect that the revised data would be expected to have on the performance of the new facility and its impact on the IESO-controlled grid.

2. Revised Data

The following Table summarises the principal data values that were used in each of the earlier Reports together with the data that were used in the studies covered by this 3rd Addendum:

Generator Data:				
		<i>Rating</i>	<i>Sub-transient Reactance</i>	
Addendum No. 1 <i>Based on two separate trains, each with one gas-turbine & one steam-turbine</i>				
<i>Asymmetrically connected - with two GTs on the western half & two STs on the eastern half of the Hearn busbar</i>				
	Gas-Turbine Generator	234MVA	16.6% on 234MVA _{base}	
	Steam-turbine Generator	115.6MVA	17.0% on 115.6MVA _{base}	
Addendum No. 2 <i>Based on a three-unit arrangement consisting of two gas-turbines & one steam-turbine unit</i>				
<i>Asymmetrically connected - with two GTs on the western half & one STs on the eastern half of the Hearn busbar</i>				
	Gas-Turbine Generator	225MVA	18.5% on 225MVA _{base}	
	Steam-turbine Generator	265MVA	25.0% on 265MVA _{base}	
Addendum No. 3 <i>Based on a three-unit arrangement consisting of two gas-turbines & one steam-turbine unit</i>				
<i>Asymmetrically connected - with two GTs on the western half & one STs on the eastern half of the Hearn busbar</i>				
	Gas-Turbine Generator	199.3MVA	16.84% on 199.3MVA _{base}	
	Steam-turbine Generator	287.6MVA	16.3% on 287.6MVA _{base}	
Step-up Transformer Data:				
		<i>Rating</i>	<i>Reactance</i>	
			<i>Positive Seq.</i>	<i>Zero Seq.</i>
Addendum No. 1	For the Gas-turbine Units	235MVA	13.0% on 235MVA _{base}	90% of positive sequence impedance
	For the Steam-turbine Units	115MVA	13.0% on 115MVA _{base}	
Addendum No. 2	For the Gas-turbine Units	235MVA	13.0% on 235MVA _{base}	
	For the Steam-turbine Unit	280MVA	13.7% on 280MVA _{base}	12.4%
Addendum No. 3	For the Gas-turbine Unit G1	127.5/170/212.5MVA	7.42% on 127.5MVA _{base}	90% of positive sequence impedance
	For the Gas-turbine Unit G2	127.5/170/212.5MVA	7.45% on 127.5MVA _{base}	
	For the Steam-turbine Unit	180/240/300MVA	7.40% on 180.0MVA _{base}	

3. Connection Arrangement

Diagram 1 shows the revised connection arrangement for the three generating units at the Portlands Energy Centre.

The principal change between the arrangement that is currently being implemented and that shown in the 2nd Addendum is the installation of synchronising breakers in the LV connections of each generating unit and the elimination of all of the 115kV breakers at the Portlands Energy Centre.

4. Fault Level Results

Since the 2nd Addendum was issued on 15th March 2005, decisions have been taken regarding the following developments within the GTA:

- The replacement of two of the existing 230kV diameters at Claireville TS and the installation of a third diameter on the eastern half of the 230kV switchyard. Additional breakers are also to be installed so that each of the six diameters at Claireville TS will be fully equipped. This will allow the 230kV terminations at the station to be reconfigured so that the eventual loading on each half of the 230kV busbar will be balanced.

The termination of the idle 230kV circuit between Claireville TS and Richview TS so that each half of the 230kV busbar at Claireville TS will have three circuits to Richview TS associated with it.

Once completed in October-2009, these changes will allow the 230kV busbar at Claireville TS to be operated open and thereby maintain the fault levels at Claireville TS within the breaker ratings.

- With the expectation that the 230kV busbar at Claireville TS will be operated open, Hydro One has deferred indefinitely their plans to introduce 230kV switching devices (either circuit-switchers or breakers) into circuits V71RP and V75P between Claireville TS and Parkway TS that would then have allowed these connections to be operated open.

In addition, a contract has been awarded to Bruce Power for the return to service of units G1 & G2 at the Bruce Complex. In response to this, Hydro One is seeking approval for a new 500kV double-circuit line between the Bruce Complex and Milton TS to accommodate all eight units at the Bruce Complex together with the 725MW of committed wind-turbine projects in the Bruce area.

In their recently released Integrated Power System Plan, the OPA has proposed the installation of 230kV auto-transformers at Milton TS and the expansion of the existing 230kV transmission facilities to provide new 230kV connections between Milton TS and Claireville TS, via Hurontario TS.

These new facilities will not only improve the reliability of the supply to the increasing loads in the Milton, Georgetown, Streetsville, Brampton and northern Mississauga areas, but they will also enhance the integration of both the Sithe-Goreway and the Halton Hills generating projects into the transmission system in the north-western portion of the GTA.

The system model that was used for the fault level analysis was revised accordingly.

The results obtained from these fault level studies have been summarised in Table 1.

4.1 Comments on the Fault Level Analysis

As a direct consequence of having to operate with the 230kV busbars at Leaside TS and the 115kV busbars at both Leaside TS and Hearn SS open to limit the fault levels on the 115kV busbar at Leaside TS, the following contingency conditions will result in the simultaneous loss of two of the auto-transformers on either the eastern or the western halves of the Leaside 115kV busbar:

<i>Contingency Condition</i>	<i>Auto-transformers removed from service</i>
1. A double-circuit contingency involving the 230kV circuits C16L & C17L , between Cherrywood TS and Leaside TS	T16 & T17 on the <i>western</i> half of the Leaside busbar
2. A double-circuit contingency involving the 230kV circuits C2L & C3L , between Cherrywood TS and Leaside TS	T11 & T12 on the <i>eastern</i> half of the Leaside busbar

Since the simultaneous loss of two of the Leaside auto-transformers could have serious implications on the supply reliability, particularly for the disproportionately higher load supplied from the western half of the Leaside 115kV busbar, it was therefore recommended that two of the 230kV connections between Cherrywood TS and Leaside TS should be interchanged at their Leaside terminals.

The arrangement that was selected for implementation is shown in Diagram 2. This would involve the interchange of circuits C3L & C17L between their respective connections to the 230kV bus-tie breaker L3L17 and their connections on to the auto-transformers T12 & T17. A contingency involving any of the three double-circuit lines between Cherrywood TS and Leaside TS would then result in the loss of only a single auto-transformer from each side of the Leaside busbar.

This interchange of circuits C3L & C17L was included in the model that was used to obtain the fault level results summarised in Table 1.

The results in the upper portion of Table 1 correspond to the condition with no reactor installed in the neutral connection of each generator step-up transformer.

The results in the lower portion show the reduction in the single L-G fault currents resulting from the installation of a 2 ohm neutral reactor on each step-up transformer.

These results show that without the neutral reactors, the asymmetrical SLG fault currents at Hearn SS would be substantially in excess of the breaker ratings (approximately 2.5kA on the western half & 1.5kA on the eastern half). However, while the neutral reactors are shown to reduce the asymmetrical SLG fault current at Leaside TS by approximately 0.6kA, the projected fault current would still exceed the rating of the breakers at Leaside by approximately 0.9kA.

A potential solution to the excessive fault levels on the western half of the Leaside 115kV busbar would be to remove one of the auto-transformers associated with this half of the Leaside busbar from service pre-contingency. However, this would effectively defeat the object of interchanging of the 230kV circuits on the Cherrywood-Leaside corridor.

The study was therefore re-run for the condition with no interchange of the 230kV circuits at Leaside TS.

The results for the critical 115kV busbars at Leaside TS & Hearn SS have been summarised in Table 2

These results show that with no interchange of the 230kV circuits C3L & C17L, the fault levels for a three-phase fault would remain within the breaker ratings at both Leaside TS and Hearn SS. They also show that the installation of 2 ohm neutral reactors on the step-up transformers at the Portlands Energy Centre would be sufficient to maintain the fault levels at Leaside TS just marginally within their breaker ratings, while providing a margin of approximately 2.5kA at Hearn SS.

TABLE 1		Fault Level Results - With the Portlands Energy Centre project in-service					
<p><i>Leaside 230kV & 115kV busbars OPEN & Hearn 115kV busbar OPEN</i> <i>Claireville 230kV busbar OPEN & with a 6th Claireville x Richview circuit in-service</i> <i>Claireville x Parkway 230kV circuits CLOSED</i></p> <p><i>With the 230kV circuits C3L & C17L between Cherrywood x Leaside Interchanged</i> <i>With a new 500kV double-circuit line from Bruce to Milton & three 500/230kV auto-transformers at Milton TS</i> <i>With revised 230kV connections between Milton TS & Claireville TS, via Hurontario TS</i> <i>With the Sithe-Goreway & Halton Hills Projects in-service</i> <i>With additional generation in the South-west GTA: Cooksville 230kV busbar OPEN</i></p>							
		<i>Symmetrical</i>		<i>Asymmetrical</i>		<i>Breaker Ratings</i>	
		<i>3-phase</i>	<i>L-G</i>	<i>3-phase</i>	<i>L-G</i>	<i>Symmetrical</i>	<i>Asymmetrical</i>
Claireville 500kV		54.73	52.76	69.34	58.88	80.0kA	96.0kA
Claireville 220kV	<i>West</i>	62.79	65.78	78.80	78.28	80.0kA	96.0kA
	<i>East</i>	62.18	64.60	78.09	76.87		
Milton 500kV		45.54	43.93	56.38	50.69	80.0kA	96.0kA
Milton 230kV		54.86	63.07	70.12	79.02	80.0kA	96.0kA
Cherrywood 230kV	<i>DK1</i>	49.42	53.43	64.10	67.69	60.0kA <i>(minimum)</i>	70.3kA <i>(minimum)</i>
	<i>DK2</i>	46.22	50.37	60.45	64.47		
	<i>DK3</i>	45.44	48.57	58.94	62.17		
	<i>DK4</i>	47.31	51.29	60.84	64.98		
Trafalgar 230kV		55.63	53.98	62.08	58.19	63.0kA	76.0kA
Burlington 230kV		48.92	41.82	54.60	45.09	63.0kA	76.0kA
Hurontario 230kV	<i>V72R</i>	27.67	23.15	32.40	24.12	63.0kA	76.0kA
	<i>V73R</i>	27.55	23.02	32.27	23.99		
	<i>R19T</i>	28.27	23.10	31.01	23.72		
	<i>R21T</i>	28.27	23.12	31.01	23.74		
Cooksville 230kV	<i>B15C</i>	27.81	27.54	34.07	32.25	63.0kA	76.0kA
	<i>B16C</i>	40.02	41.70	48.59	48.83		
Richview 220kV	<i>West</i>	62.87	61.22	77.01	67.16	69.5kA	83.4kA
	<i>East</i>	62.62	60.57	76.96	67.60		
Leaside 115kV	<i>West</i>	33.47	37.54	42.54	47.04	39.3kA	45.5kA
	<i>East</i>	31.88	36.00	40.90	44.03		
Hearn 115kV	<i>West</i>	27.57	28.80	34.38	36.55	31.4kA	34.1kA
	<i>East</i>	27.24	28.77	33.67	35.65		
Manby 230kV	<i>West</i>	45.25	45.27	53.80	52.10	70.0kA	80.4kA
	<i>East</i>	42.37	41.56	49.95	47.96		
Manby 115kV	<i>West</i>	28.78	34.23	38.19	44.67	38.8kA	45.5kA
	<i>East</i>	27.57	33.04	36.28	43.12		
With 2.0 ohm reactors in the neutrals of the step-up transformers							
Leaside 115kV	<i>West</i>	33.47	37.04	42.54	46.41	39.3kA	45.5kA
	<i>East</i>	31.88	35.08	40.90	43.39		
Hearn 115kV	<i>West</i>	27.57	25.53	34.38	31.91	31.4kA	34.1kA
	<i>East</i>	27.24	26.36	33.67	31.23		

TABLE 2		Fault Level Results - With the Portlands Energy Centre project in-service					
<p><i>Leaside 230kV & 115kV busbars OPEN & Hearn 115kV busbar OPEN</i> <i>Claireville 230kV busbar OPEN & with a 6th Claireville x Richview circuit in-service</i> <i>Claireville x Parkway 230kV circuits CLOSED</i></p> <p>With no interchange of the 230kV circuits C3L & C17L between Cherrywood x Leaside <i>With a new 500kV double-circuit line from Bruce to Milton & three 500/230kV auto-transformers at Milton TS</i> <i>With revised 230kV connections between Milton TS & Claireville TS, via Hurontario TS</i> <i>With the Sithe-Goreway & Halton Hills Projects in-service</i> <i>With additional generation in the South-west GTA: Cooksville 230kV busbar OPEN</i></p>							
		<i>Symmetrical</i>		<i>Asymmetrical</i>		<i>Breaker Ratings</i>	
		<i>3-phase</i>	<i>L-G</i>	<i>3-phase</i>	<i>L-G</i>	<i>Symmetrical</i>	<i>Asymmetrical</i>
<i>Leaside 115kV</i>	<i>West</i>	32.94	36.87	42.26	46.22	39.3kA	45.5kA
	<i>East</i>	31.05	34.99	40.55	43.32		
<i>Hearn 115kV</i>	<i>West</i>	27.18	28.60	33.89	36.30	31.4kA	34.1kA
	<i>East</i>	26.66	28.28	33.30	35.04		
With 2.0 ohm reactors in the neutrals of the step-up transformers							
<i>Leaside 115kV</i>	<i>West</i>	32.94	36.24	42.26	45.41	39.3kA	45.5kA
	<i>East</i>	31.05	33.94	40.55	42.50		
<i>Hearn 115kV</i>	<i>West</i>	27.18	25.23	33.89	31.54	31.4kA	34.1kA
	<i>East</i>	26.66	25.79	33.30	30.56		

4.2 Change in the fault levels from those recorded in the 2nd Addendum

Table 3 shows the fault levels at the Hearn & Leaside 115kV busbars that were recorded in the 2nd Addendum.

Table 4 shows the respective increases between the fault levels shown in Table 1, for the condition with the 230kV circuits interchanged, and those shown in Table 3 for the same system condition.

TABLE 3		Fault Level Results - With the Portlands Energy Centre project in-service					
Extracted from the 2nd Addendum issued on 15th March 2005							
<p><i>Leaside 230kV & 115kV busbars OPEN & Hearn 115kV busbar OPEN</i> <i>Claireville 230kV busbar CLOSED & with 5 Claireville x Richview circuit in-service</i> <i>Claireville x Parkway 230kV circuits OPEN</i></p> <p>With the 230kV circuits C3L & C17L between Cherrywood x Leaside Interchanged With no new 500kV line to the Bruce Complex <i>With the Sithe-Goreway & Boralex Projects in-service</i> <i>With the Sithe-Southdown Project in-service in the South-west GTA: Cooksville 230kV busbar CLOSED</i></p>							
		<i>Symmetrical</i>		<i>Asymmetrical</i>		<i>Breaker Ratings</i>	
		<i>3-phase</i>	<i>L-G</i>	<i>3-phase</i>	<i>L-G</i>	<i>Symmetrical</i>	<i>Asymmetrical</i>
<i>Leaside 115kV</i>	<i>West</i>	32.57	35.60	42.14	44.60	39.3kA	45.5kA
	<i>East</i>	30.10	34.10	39.34	42.73		
<i>Hearn 115kV</i>	<i>West</i>	27.61	28.96	35.01	37.04	31.4kA	34.1kA
	<i>East</i>	25.62	26.90	31.36	33.00		

TABLE 4		Comparison of the Fault Levels recorded in the 2nd & 3rd Addenda				
		Symmetrical		Asymmetrical		
		3-phase	L-G	3-phase	L-G	
Leaside 115kV	2nd Addendum	West	32.57	35.60	42.14	44.60
	3rd Addendum	West	33.47	37.54	42.54	47.04
	Increase		0.90kA	1.94kA	0.40kA	2.44kA
	2nd Addendum	East	30.10	34.10	39.34	42.73
	3rd Addendum	East	31.88	36.00	40.90	44.03
	Increase		1.78kA	1.90kA	1.56kA	1.30kA
Hearn 115kV	2nd Addendum	West	27.61	28.96	35.01	37.04
	3rd Addendum	West	27.57	28.80	34.38	36.55
	Increase		-0.04kA	-0.16kA	-0.63kA	-0.49kA
	2nd Addendum	East	25.62	26.90	31.36	33.00
	3rd Addendum	East	27.24	28.77	33.67	35.65
	Increase		1.62kA	1.87kA	2.31kA	2.65kA

The effect on the fault levels at Hearn SS of the revised data that has been provided for the generating units that are now being installed at the Portlands Energy Centre are clearly reflected in the incremental changes that are shown the Table above.

This shows an overall reduction in the fault levels on the western half of the Hearn busbar as a result of the lower rating of the gas-turbine units (~11%), even though the sub-transient reactance has also declined (~9%).

For the eastern half of the Hearn busbar, the fault levels are shown to be substantially higher due to the combined effect of the increased rating of the steam-turbine unit (~8.5%) and its lower sub-transient reactance (~35%).

These changes in the machine parameters, together with those system reinforcements that are expected to be implemented within the next five years and which have therefore been included in the system model used for the fault level analysis, are shown to result in substantial increases in the fault levels at Leaside TS, particularly on the eastern half of the busbar.

4.3 Conclusions from the fault level analysis

Although the increases in the fault levels on the *eastern* halves of the busbars at both Hearn SS and Leaside TS have been shown to be proportionally higher than those on the western halves, they would not be sufficient to result in the breaker ratings being exceeded once the neutral reactors have been installed.

However, since the proposed interchange of the 230kV circuits C3L & C17L will provide an indirect connection between the eastern & western halves of the Leaside sector, increases in the fault levels on the eastern halves of the busbars will have an influence on the fault levels appearing on the western halves. This effect is evident in the Table above where the fault levels on the western half of the Leaside busbar are shown to increase by a lesser amount than those on the eastern half. Had the increases in the fault levels on the 115kV busbars at Leaside TS been due entirely to the system changes that have been assumed, then the increases would have been expected to be similar.

Even though the increases in the fault levels on the western halves of the busbars at Hearn SS and Leaside TS are shown to be more moderate than those on the eastern halves, they would be sufficient to cause the breaker ratings to be exceeded, even with the neutral reactors in-service.

Measures will therefore be required during those periods when high levels of generating capacity are dispatched to ensure that the fault levels on the western halves of the busbars at Hearn SS and Leaside TS remain within the breaker ratings.

These measures could involve either of the following:

- The deferral of the interchange of circuits C3L & C17L until a permanent solution to the fault level issue can be implemented.
- The temporary removal of one of the auto-transformers associated with the western half of the busbar at Leaside TS from service, pre-contingency.

5. *Generation Rejection & Cross-Tripping Scheme*

While there are only a limited number of contingencies when all elements are initially in-service, that could result in post-contingency overloading of the remaining 115kV circuits in the Leaside sector, it is expected that overloading would occur in response to most contingencies whenever critical transmission elements are unavailable. In order to ensure that the Portlands Energy Centre would still be able to operate at full output during those periods when transmission facilities are out-of-service, a functional specification for a Generation Rejection & Cross-tripping Scheme has been developed.

The proposed Generation Rejection & Cross-Tripping Scheme is shown in Diagram 3.

6. *Assessment of the Performance of the Generating Units*

6.1 *Data Supplied*

The data that were provided for the machines to be installed at the Portlands Energy Centre and that were used in the analysis to assess the performance of the equipment are summarised in the following Diagrams:

		<i>PTI Model Used</i>
Diagram 4	Generator Parameters	GENROU
Diagram 5	Excitation System for the Steam-turbine generating unit	ESST1A
Diagram 6	Power System Stabiliser for the Steam-turbine generating unit	PSS2A
Diagram 7	Excitation System for the Gas-turbine generating units	ESST4B
Diagram 8	Power System Stabiliser for the Gas-turbine generating units	PSS2A
Diagram 9	Governor for the Steam-turbine generating unit	IEESG1
Diagrams 10 & 11	Governor for the Gas-turbine generating units	GGOV1

6.2 *Exciter Performance*

Response Ratio Test

Diagram 12 shows the results for the initial 1.0-second period of the response ratio test for a large increase in the reference set points for the voltage regulators.

This shows that in response to the imposed change in the reference settings the exciter field voltages would increase by the following amounts from their full load values to their ceiling voltages:

- for the steam-turbine exciters: an increase from 2.91pu to 6.50pu equivalent to 223%
- for the gas-turbine exciters: an increase from 2.66pu to 6.57pu equivalent to 247%

This Diagram also shows the nominal responses of the respective exciters.

These are as follows:

- for the exciters on the gas-turbine units: a response ratio of 5.7
- for the exciters on the steam-turbine units: a response ratio of 4.9

Open-Circuit Step Response

Diagram 13 shows the open-circuit response to a step change of 5% in the generator terminal voltage. In the upper half of the Diagram the response is shown for the initial 10 second period, while that in the lower half corresponds to just the initial 1.0-second period

This shows that the exciter of the steam-turbine unit will reach a maximum voltage of 2.50pu within 50-milliseconds, while the exciters on the gas-turbine units will reach a maximum voltage of 3.40pu.

6.3 Comments on the Performance of the Exciters

Diagram 13 shows that the exciters on the gas-turbine & the steam-turbine units are able to achieve a ceiling voltage of at least twice the rated field voltage as required by the Market Rules.

The Market Rules also require that the exciters have a voltage response time no longer than 50 milliseconds. This means that the exciters are required to attain a field voltage of 95% of the difference between the rated load field voltage and the ceiling voltage within a maximum time of 50-milliseconds.

Since the rated full load field voltages for the exciters on the steam-turbine & gas-turbine units are 2.91pu & 2.66pu, respectively (from Diagram 12) and the required ceiling voltage capability is twice that, then the minimum requirement under the Market Rules is that the outputs of the exciters increase by the following amounts within 50 milliseconds:

- for the exciter on the steam-turbine unit an increase of at least: 2.53pu.
- for the exciters on the gas-turbine units an increase of at least: 2.76pu

In Diagram 13, since the initial outputs from the exciters of all three generating units are shown as 1.07pu, then the minimum values that the exciter voltages are required to achieve within 50 milliseconds, following a 5% increase in the generator terminal voltage, will be as follows:

- for the exciter on the steam-turbine unit an output voltage of at least: 3.60pu.
- for the exciters on the gas-turbine units an output voltage of at least: 3.83pu

Diagram 13 shows that the maximum voltage that the exciters on the steam-turbine & the gas-turbine units would be able to achieve would be only 2.50pu and 3.40pu, respectively. The settings that have been proposed for the exciters would therefore not satisfy the Market Rules.

6.4 Governor Responses

Diagram 14 shows the response of the individual governors to a 0.1pu change in the mechanical loading on the turbines.

Since the deviation in the speed of the gas-turbine units is still shown to be increasing at the end of the 10 second period following the application of the initial step-change in the loading, the response has been re-plotted for a 30 second interval, together with a change in the scale used for the rotor speed deviation. The revised plot for the extended period is shown in Diagram 15.

While the response of the governor on the steam-turbine would be acceptable to the IESO, the response shown for those governors on the gas-turbines would not be acceptable. Diagram 15 shows that the gas-turbine governors would not be able to sustain a 0.1pu change in the loading and that the speed of the gas-turbines units would decline by 0.04pu. This means that if the gas-turbine units were to be operated in isolation and be subjected to a 0.1pu increase in their loading, the frequency would be expected to fall by 2.4Hz.

It should also be noted that the Market Rules require the governors to have droop settings that are adjustable within the range of 3% to 7% and that the actual droop setting for the *entire* combined-cycle facility is to have a composite value of no more than 5%.

6.5 Verification of Machine & Transformer Parameters and the Exciter/Power System Stabiliser Settings

The IESO requires evidence to be provided confirming the validity of the data used in this assessment.

This should consist of the following documentation:

Generators

- Copies of the type-test to IEEE Standard 115 for each of the different generating units that are to be installed on this Project or the results from equivalent on-site tests.
- Generator Commissioning Tests:
 - Specifically -
 - results to confirm the saturation curves;
 - results to demonstrate the capability to achieve the stated values of Q_{max} and Q_{min} ;
 - tabulated results displaying the following values for a selected range of outputs:
Power (P) Reactive Power (Q) Terminal Voltage (V_{Term}) Field Current (I_f)

Generator Step-up Transformers

- Copies of the results from the *Impedance & Ratio* tests performed in accordance with IEEE Standard C57.12.90

Generator Controls

Provide documentation to demonstrate compliance with the Market Rules.

Specifically:

For the Excitation Systems -

- that the voltage response time is not longer than 50msec for a maximum step change of 5% in the voltage reference;
- that the positive ceiling voltage is at least 200% of the rated field voltage; and
- that the negative ceiling voltage is at least 140% of the rated field voltage

For the Power System Stabilisers -

- provide the results from a series of response tests at different stabiliser gain settings that were performed to determine the preferred gain setting

For the Speed Governors -

- that the deadband is less than ± 36 mHz;
- that the composite speed droop for the entire facility is 5% or better; and
- that control systems that inhibit governor response shall be automatically disabled by frequency deviations not larger than ± 100 mHz.

7. Response to faults on the 115kV system

Diagram 16 shows the simplified system model that was used in the transient analysis.

Normally-cleared, three-phase faults were applied at the locations shown below. The fault clearance times that were assumed in the analysis are also shown in Diagram 16.

It should be noted that while the breakers at Leaside TS and Cecil TS are 3-cycle units, the operating time for those breakers at Hearn TS has been quoted as 5-cycles.

On the western half of the Leaside sector -

- At the Hearn terminal of 115kV circuit H6LC The results are shown in Diagram 17
- At the Leaside terminal of 115kV circuit H6LC The results are shown in Diagram 18

On the eastern half of the Leaside sector -

- At the Hearn terminal of 115kV circuit H1L The results are shown in Diagram 19
- At the Leaside terminal of 115kV circuit H1L The results are shown in Diagram 20

All four Diagrams show very similar responses for the fault conditions examined, with only minor changes in the maximum angular swings experienced depending on whether the fault location examined was at the Hearn terminal or the Leaside terminal of the selected circuit. In all cases the angular swing is shown to be less than 27° .

8. Constant Power Factor versus Constant Voltage Mode of Operation

Although it is a requirement that the generating units have the capability of operating either to maintain their output at a constant power factor or to maintain a constant voltage at their terminals, the IESO requires that in practice they be operated in a Constant Voltage mode. The generating units should therefore be operated to control their respective terminal voltages to set values, and that these set-points be adjusted periodically, upon instructions from the IESO, to ensure that the prevailing reactive power requirements of the system are satisfied.

9. Generator Under-Frequency Tripping

Generating facilities are required to operate continuously at full power in the range 59.4Hz to 60.6Hz and for the limited times shown in Figure 1 (from NPCC Document A-3: Emergency Operating Criteria). For frequencies below 57.0Hz, immediate tripping of the facility is allowed.

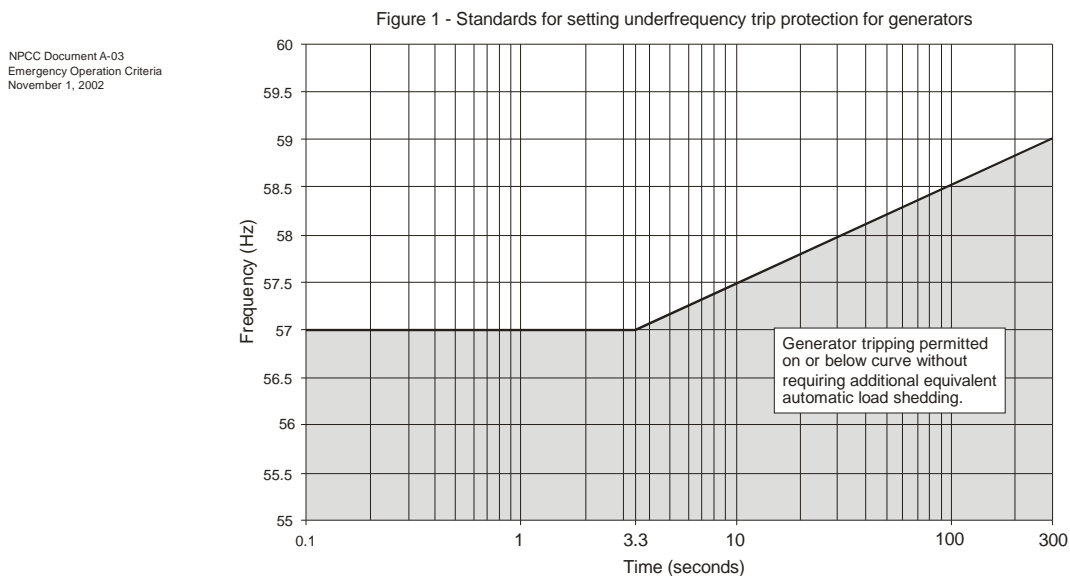

10. Conclusions & Recommendations

The conclusions drawn from the analysis that was performed for this assessment, together with any associated recommendations, can be summarised, as follows:

- i. The generating units as now proposed, together with the system changes that are expected to be implemented during the next five years, will result in fault levels at both Hearn SS and Leaside TS that will be substantially higher than those identified in Addendum No. 2, even with reactors installed in the neutral connection of each of the generator step-up transformers at the Portlands Energy Centre. For this analysis, the 230kV & 115kV busbars at Leaside TS, together with the 115kV busbar at Hearn SS were all assumed to be operated open.

To ensure that the fault interrupting capability of the existing breakers at both Hearn SS and Leaside TS is not exceeded, it is therefore recommended that either of the following measures should be implemented to limit the fault levels:

- Defer the interchange of the 230kV circuits C3L & C17L until a permanent solution to the fault level issue can be implemented.
 - Temporarily remove one of the auto-transformers associated with the western half of the 115kV busbar at Leaside TS from service, pre-contingency, whenever high levels of generation capacity are dispatched.
- ii. To limit the fault currents for line-to-ground faults, reactors rated at 5.3 millihenries (approximately 2 ohms) are required to be installed in the neutral connection of each of the generator step-up transformers at the Portlands Energy Centre.
 - iii. To avoid restrictions on the dispatch of the Portlands Energy Centre, particularly during periods when transmission elements are out-of-service, a Special Protection System is required to allow the units to be selected for automatic run-back or rejection in response to a series of system contingencies.
 - iv. The settings proposed for the exciters on all three generating units have been shown to be inadequate to satisfy the requirements specified Market Rules. The IESO therefore requires revised settings to be implemented that will ensure compliance.
 - v. Similarly, since the settings proposed for the governors on the gas-turbines units have been shown to result in an unacceptable performance, the IESO requires revised governor settings to be implemented for the gas-turbine units.

The response recorded for the governor on the steam-turbine unit, with the settings that were submitted, would be acceptable.

- vi. The responses obtained for a first contingency involving one of the 115kV circuits between Leaside TS and Hearn SS connected to either the eastern or western halves of the busbar have shown that the units would remain transiently stable.

11. Customer Impact Assessment

Since it is considered to be outside the scope of this assessment, it is expected that Hydro One, as part of their Customer Impact Assessment for this Project, will review the existing capacitor bank installations at Hearn to confirm that it will not be necessary to impose limitations on their switching operations whenever the generating units at the Portlands Energy Centre are dispatched.

12. Notification of Approval of the Connection Proposal

Since the higher than acceptable fault levels at Leaside TS are considered to be a system issue that will need to be addressed through measures that Hydro One will need to implement, no action other than the installation of the neutral reactors as detailed below, will be required by the Portlands Energy Centre.

Subject to all of the other requirements that have been detailed below, being satisfied, it is therefore recommended that a Notification of Approval to Connect be issued for the Portlands Energy Centre:

- The installation of 5.3 millihenry reactors in the neutral connection of each of the generator step-up transformers at the Portlands Energy Centre.
- The installation of the Hearn Generation Run-back/Rejection & Cross-tripping Scheme.
- The implementation of revised settings on the exciters of the gas-turbine & steam-turbine units to ensure their performance satisfies the requirements of the Market Rules.
- The implementation of revised settings on the governors of the gas-turbine units so that their performance satisfies the requirements of the Market Rules.
- The provision of commissioning results confirming both the accuracy of the data used in this assessment and that the settings as implemented will meet all of the requirements of the Market Rules.

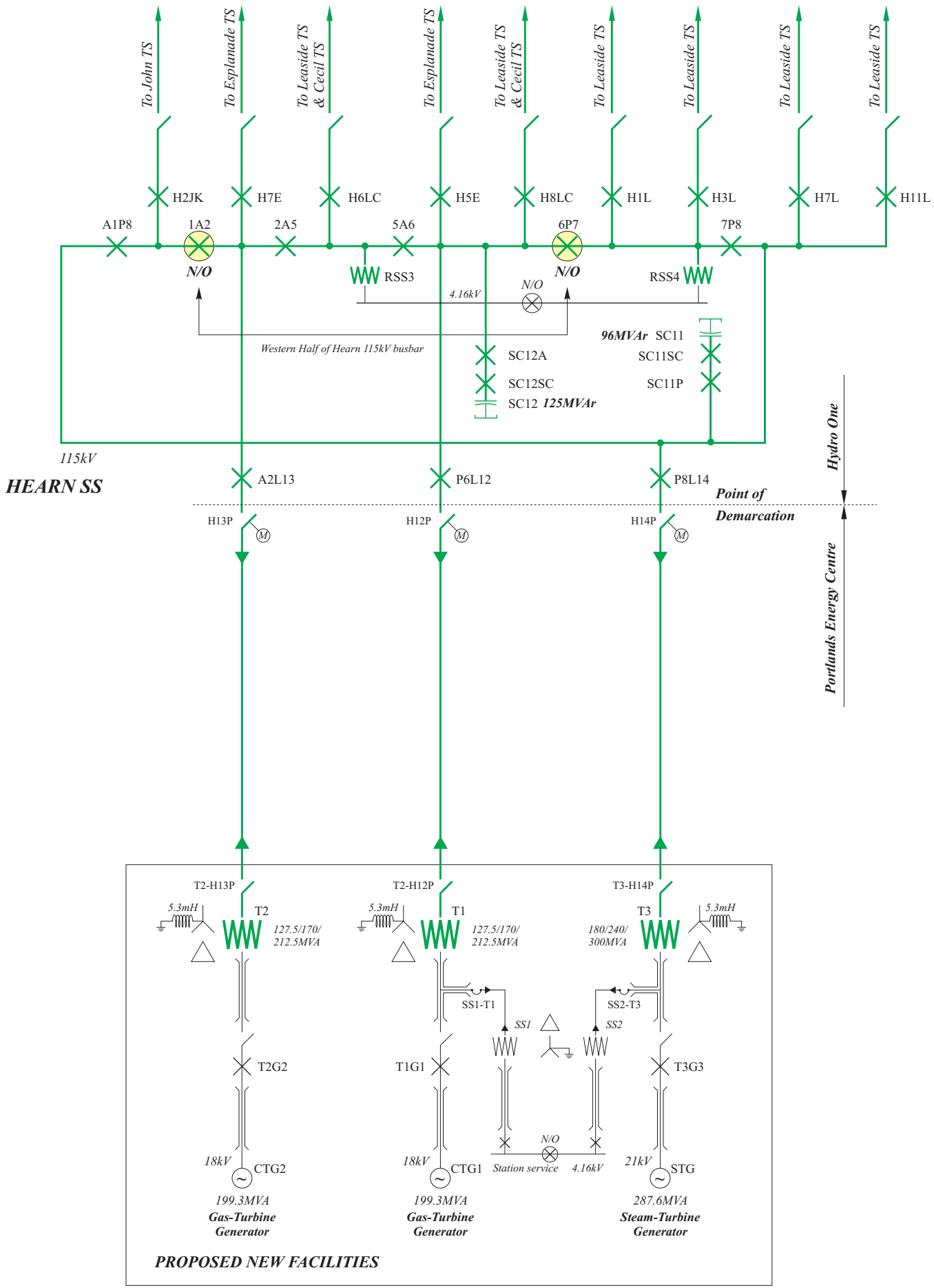

Portlands Energy Centre: 3-Unit Development
'Asymmetrical' Connection Arrangement

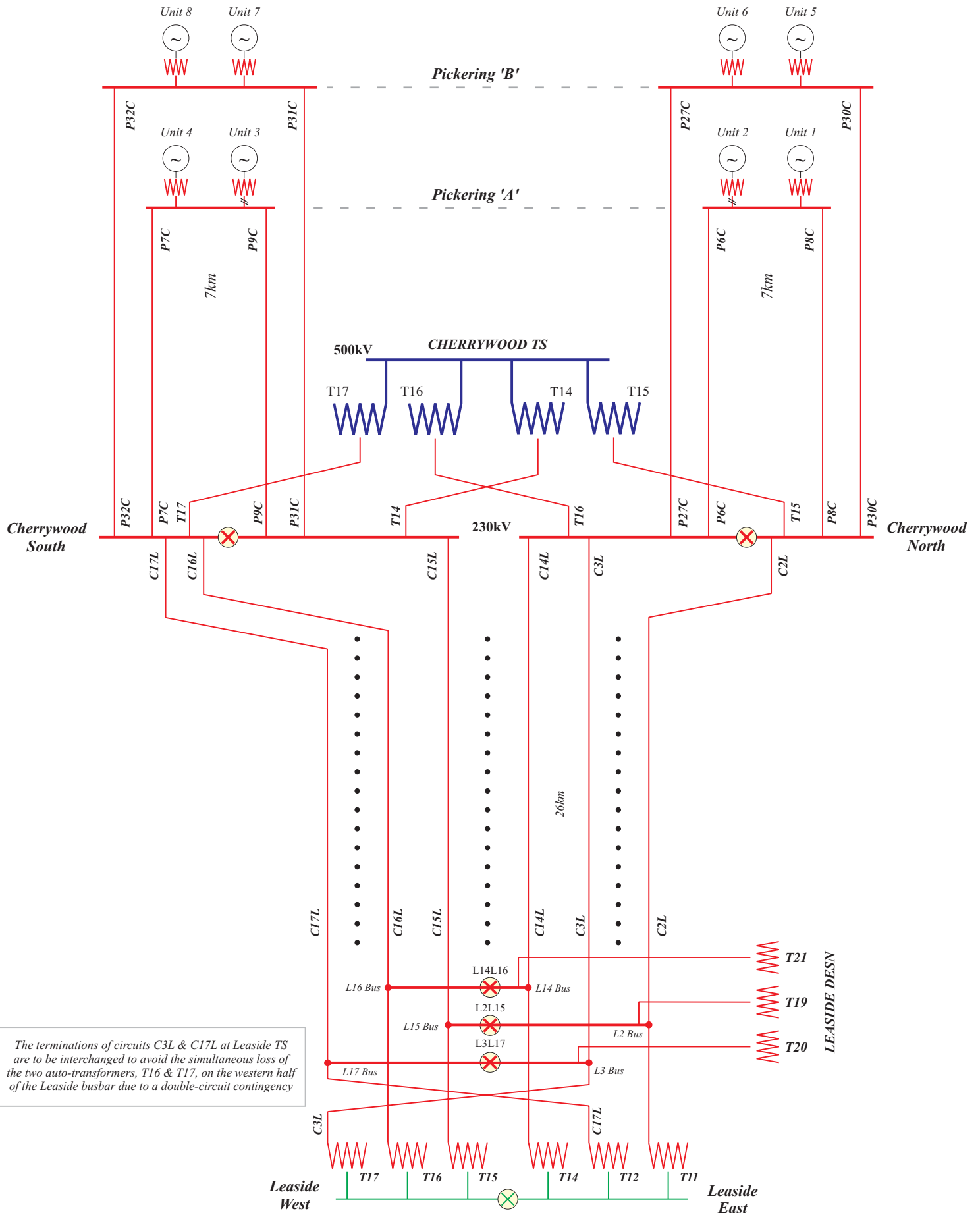

The terminations of circuits C3L & C17L at Leaside TS are to be interchanged to avoid the simultaneous loss of the two auto-transformers, T16 & T17, on the western half of the Leaside busbar due to a double-circuit contingency

Configuration of the Leaside Sector to Incorporate the Portlands Energy Centre Project

DIAGRAM 2

Data Submitted

		<i>Steam-turbine Generating Unit 287.6MVA</i>	<i>Gas-turbine Generating Units 199.3MVA</i>
Power Factor		0.85	0.85
Terminal Voltage		21kV	18kV
Open-Circuit Transient Time Constant - direct axis	T'_{do}	8.915 secs	7.011 secs
Open-Circuit Sub-Transient Time Constant - direct axis	T''_{do}	0.042 secs	0.040 secs
Open-Circuit Transient Time Constant - quadrature axis	T'_{qo}	0.929 secs	0.541 secs
Open-Circuit Sub-Transient Time Constant - quadrature axis	T''_{qo}	0.066 secs	0.082 secs
Synchronous Reactance - direct axis (Unsaturated)	X_d	2.082 pu	1.7951 pu
Synchronous Reactance - quadrature axis (Unsaturated)	X_q	1.966 pu	1.6930 pu
Transient Reactance - direct axis (Unsaturated)	X'_d	0.214 pu	0.2245 pu
Transient Reactance - quadrature axis (Unsaturated)	X'_q	0.345 pu	0.4117 pu
Sub-Transient Reactance (Unsaturated)	$X''_d = X''_q$	0.163 pu	0.1684 pu
Leakage Reactance	X_l	0.146 pu	0.1262 pu
Inertia Constant	H	6.96kW-sec/kVA	5.68kW-sec/kVA
Speed Damping	D	0.0	0.0
Saturation Factors	S (1.0)	0.07	0.067
	S (1.2)	0.216	0.579

Portlands Energy Centre Project***GENROU Model
(Round Rotor Generator Model)****Data supplied for the steam-turbine & gas-turbine generating units***DIAGRAM 4**

26th September 2007

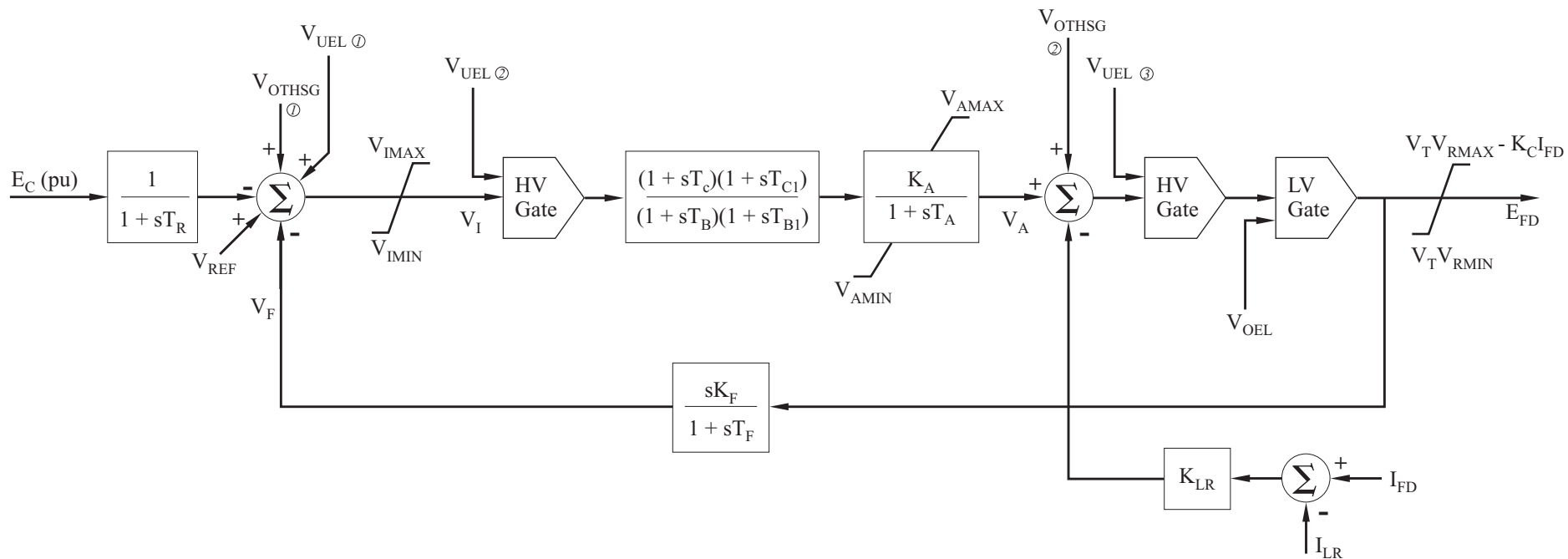

Data Submitted

K_A	1000.0	T_A	0.01 sec
K_C	0.00	T_B	125.00 sec
K_F	0.00	T_{B1}	1.00 sec
K_{LR}	0.00	T_C	5.00 sec
I_{LR}	1.00	T_{C1}	1.00 sec
V_{AMAX}	6.55	$T_F (> 0)$	1.00 sec
V_{AMIN}	-5.67	T_R	0.00 sec
V_{IMAX}	0.164		
V_{IMIN}	-0.164		
V_{RMAX}	6.55		
V_{RMIN}	-5.67		

Portlands Energy Centre Project

**ESST1A Excitation System
(IEEE Type ST1A)**

Data supplied for the Steam-turbine generating unit
at the Limestone Project

DIAGRAM 5

10th September 2007

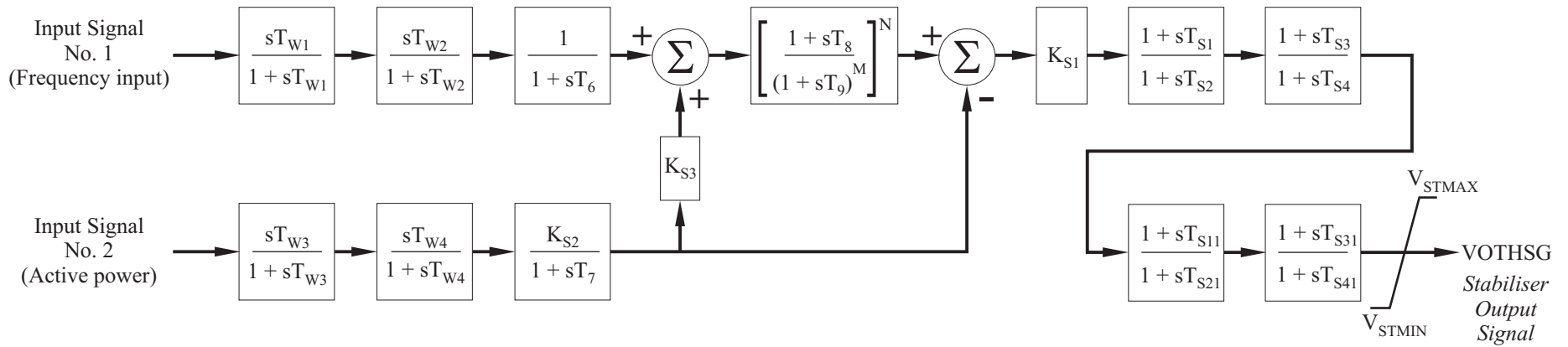

Data Submitted

ICS1	2: Bus freq. deviation	T_1	0.150 sec
ICS2	3: Gen electrical power	T_2	0.047 sec
REMBUS1	0	T_3	0.150 sec
REMBUS2	0	T_4	0.047 sec
M	4	T_6	0.000 sec
N	1	T_7	3.000 sec
K_{S1}	20	T_8	0.600 sec
K_{S2}	0.215	T_9	0.150 sec
K_{S3}	1.0	T_{11}	0.150 sec
V_{STMAX}	0.05	T_{21}	0.047 sec
V_{STMIN}	-0.05	T_{31}	1.000 sec
		T_{41}	1.000 sec
		T_{W1}	3.000 sec
		T_{W2}	3.000 sec
		T_{W3}	3.000 sec
		T_{W4}	0.000 sec

Portlands Energy Centre Project

**PSS2A Power System Stabiliser Model
(IEEE Dual-Input Stabiliser)**

Data supplied for the steam-turbine generating units

DIAGRAM 6

28th July 2006

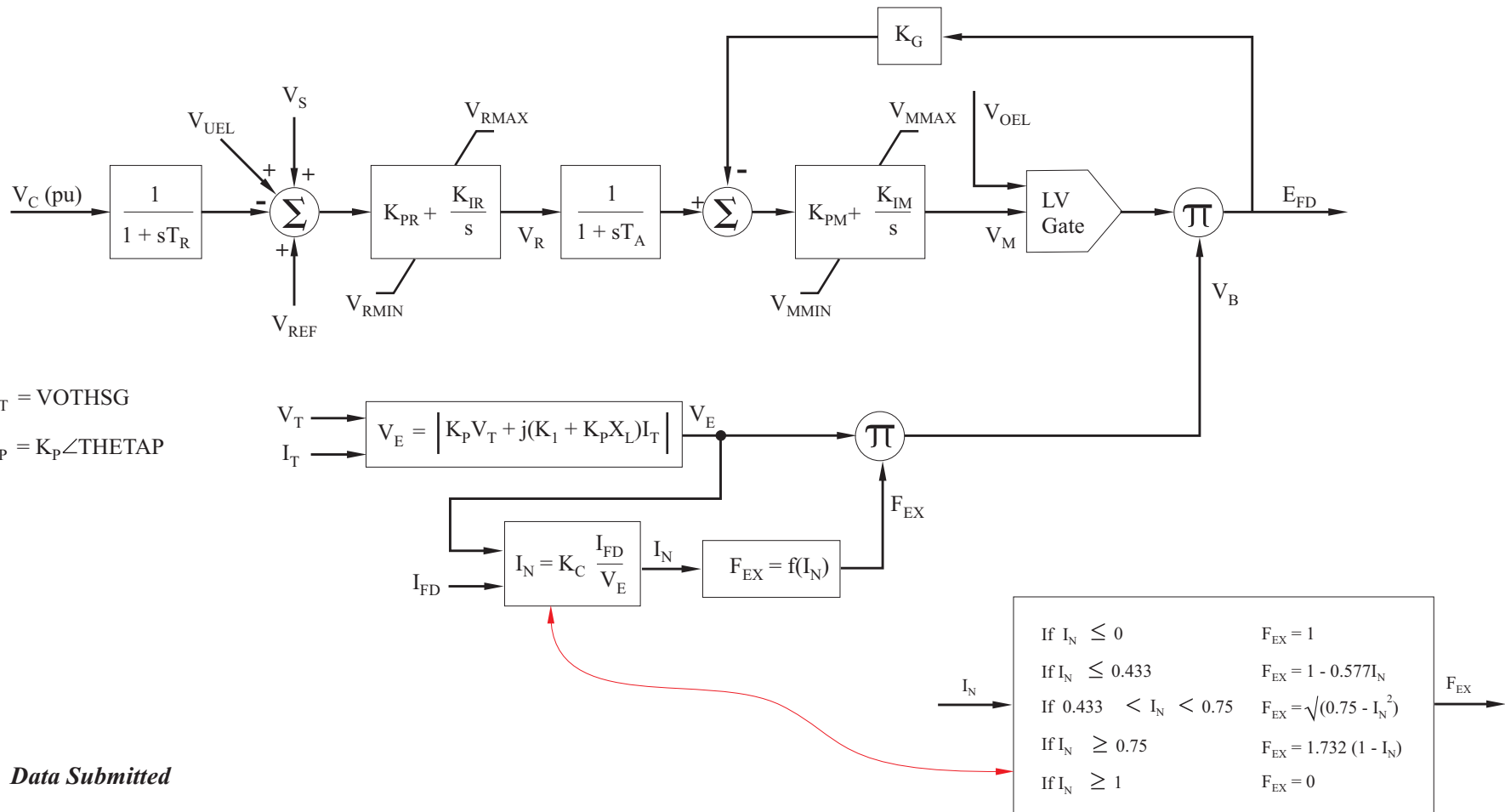

Data Submitted

K_1	0.00	T_A	0.01 sec
K_C	0.08	T_R	0.00 sec
K_G	0.00	V_{BMAX}	8.38
K_P	6.71	V_{MMAX}	1.00
K_{IM}	0.00	V_{MMIN}	-0.80
K_{IR}	7.45	V_{RMAX}	1.00
K_{PM}	1.00	V_{RMIN}	-0.80
K_{PR}	7.45	X_L	0.00
		THETAP	0.00

Portlands Energy Centre Project

ESST4B Excitation System Model
(IEEE ST4B Model)

Data supplied for the gas-turbine generating units

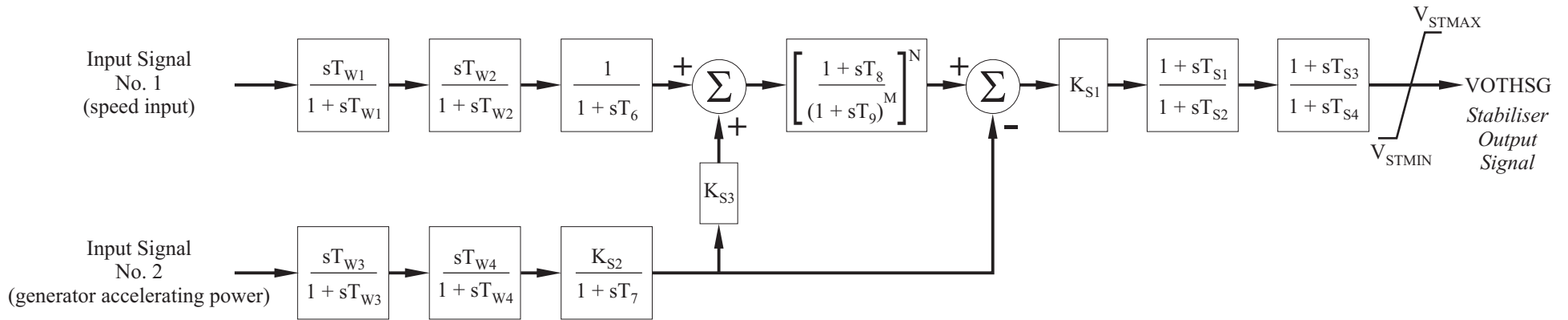

Data Submitted

ICS1	1 (Speed deviation)	T_1	0.15 sec
ICS2	3 (Electrical Power)	T_2	0.015 sec
REMBUS1	0	T_3	0.15 sec
REMBUS2	0	T_4	0.02 sec
M	5	T_6	0.00 sec
N	1	T_7	2.00 sec
K_{S1}	50	T_8	0.50 sec
K_{S2}	0.176	T_9	0.10 sec
K_{S3}	1.0	T_{W1}	2.00 sec
V_{STMAX}	0.1	T_{W2}	2.00 sec
V_{STMIN}	-0.1	T_{W3}	2.00 sec
		T_{W4}	0.00 sec

Portlands Energy Centre Project
PSS2A Power System Stabiliser Model
(IEEE Dual-Input Stabiliser)
Data supplied for the gas-turbine generating units

DIAGRAM 8

26th September 2007

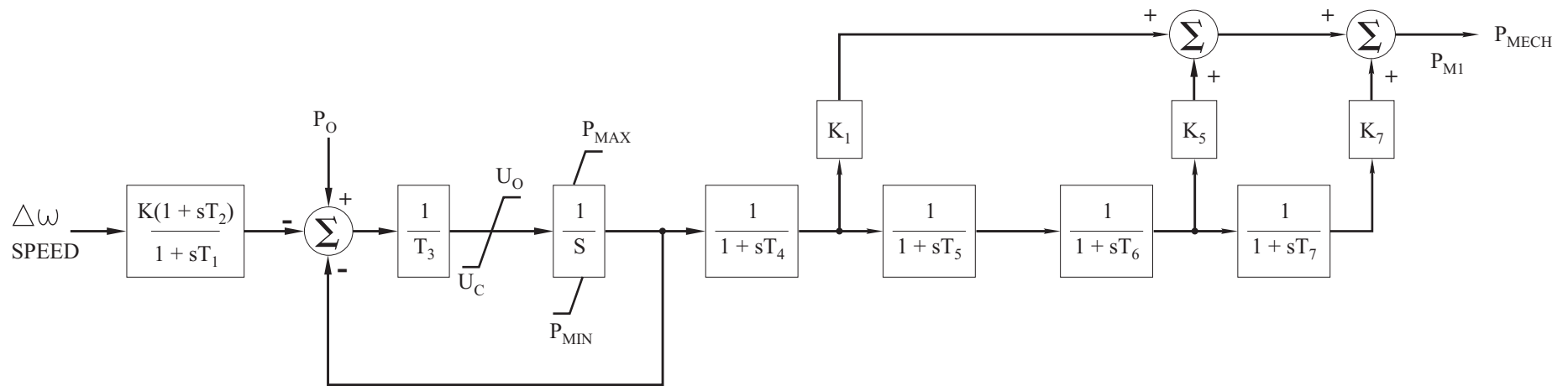

Data Submitted

K	20.00	T ₁	0.00 sec
K ₁	0.40	T ₂	0.00 sec
K ₅	0.40	T ₃	0.004 sec
K ₇	0.20	T ₄	0.10 sec
		T ₅	5.00 sec
		T ₆	0.20 sec
		T ₇	0.30 sec
		U _O	0.125
		U _C	-5.000
		P _{MAX}	1.00
		P _{MIN}	0.00

Portlands Energy Centre Project

IEEEG1 Governor Model

Data provided for the steam-turbine unit

DIAGRAM 9

10th September 2007

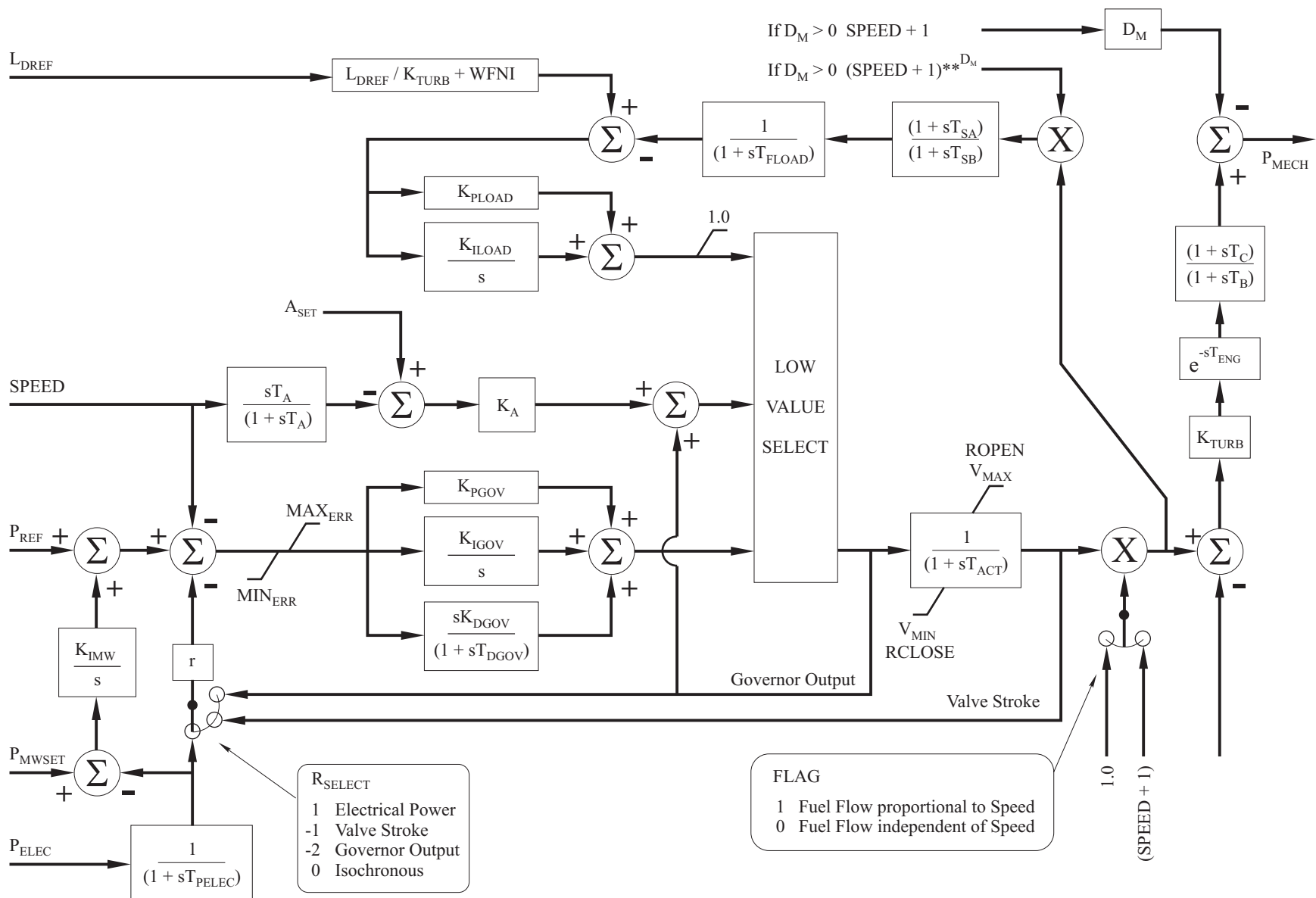

Portlands Energy Centre Project

GGOV1 Model
(Gas Turbine Governor)

DIAGRAM 10

13th September 2007

Values used in Transient Stability Analysis

T_A	0.1 sec	K_A	10.00	A_{SET}	0.01
T_B	0.1 sec	K_{DGOV}	0.00	dB	0.00
T_C	0.0 sec	K_{IGOV}	2.00	D_M	0.00
T_{ACT}	0.5 sec	K_{ILOAD}	0.67	FLAG	1.00
T_{ENG}	0.0 sec	K_{IMW}	0.00	L_{DREF}	1.0^2
T_{DGOV}	1.0 sec	K_{PGOV}	10.00	MW_{CAP}	171.70
T_{FLOAD}	3.0 sec	K_{PLOAD}	2.00	P_{MWSET}	N/A
T_{LLD}	0.0 sec	K_{TURB}	1.50	R	0.04
T_{LLN}	0.0 sec	MAX_{ERROR}	0.05	R_{UP}	99.00
T_{PELEC}	1.0 sec	MIN_{ERROR}	-0.05	R_{DOWN}	-99.00
T_{SA}	4.0 sec	V_{MAX}	1.00	R_{OPEN} (pu/sec)	0.10
T_{SB}	5.0 sec	V_{MIN}	0.15	R_{CLOSE} (pu/sec)	-0.10
				R_{SELECT}	1
				W_{FNL}	0.20

Portlands Energy Centre Project

***GGOV1 Model
(Gas Turbine Governor)***

DIAGRAM 11

26th September 2007

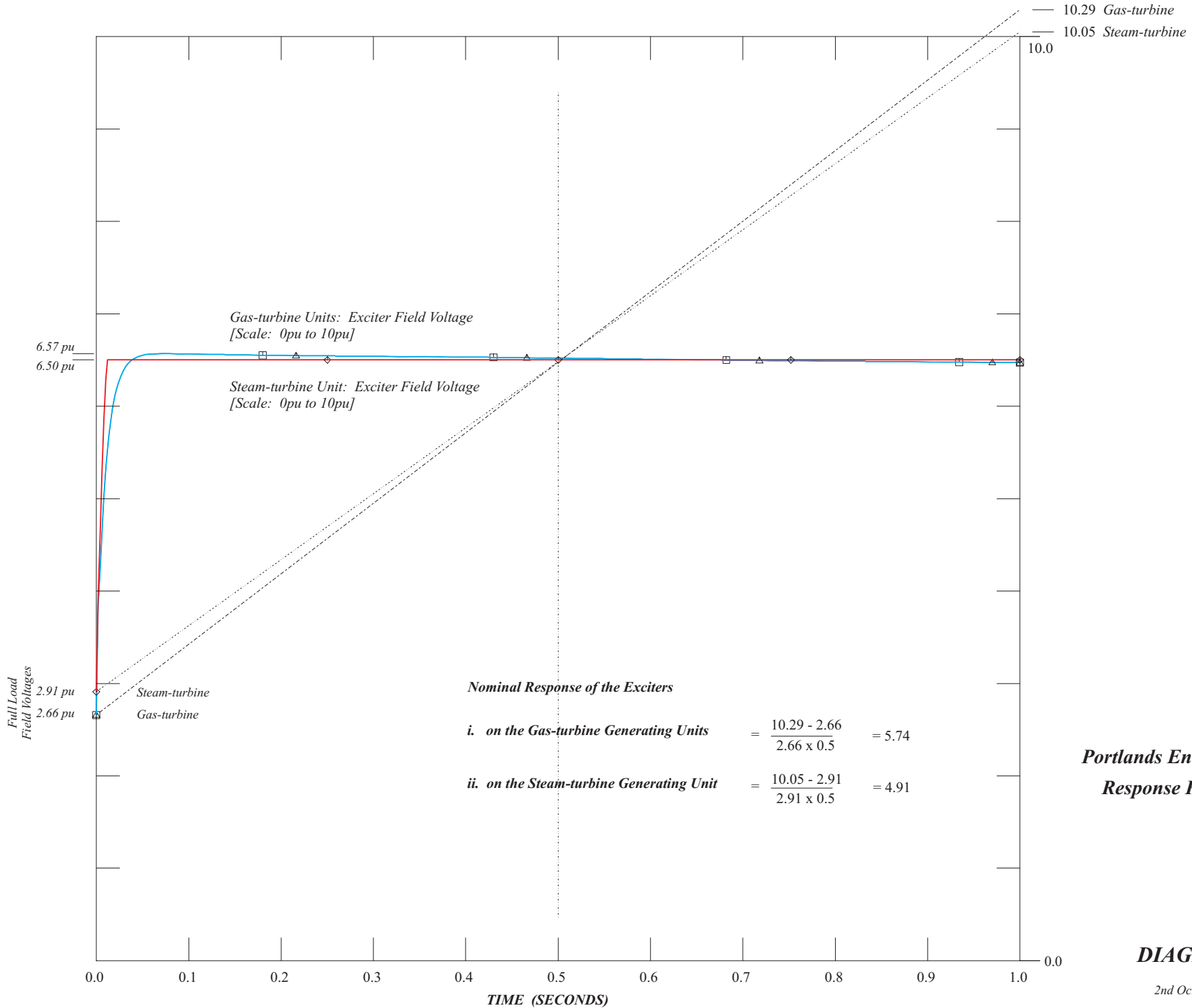

**Portlands Energy Centre
Response Ratio Test**

DIAGRAM 12

2nd October 2007

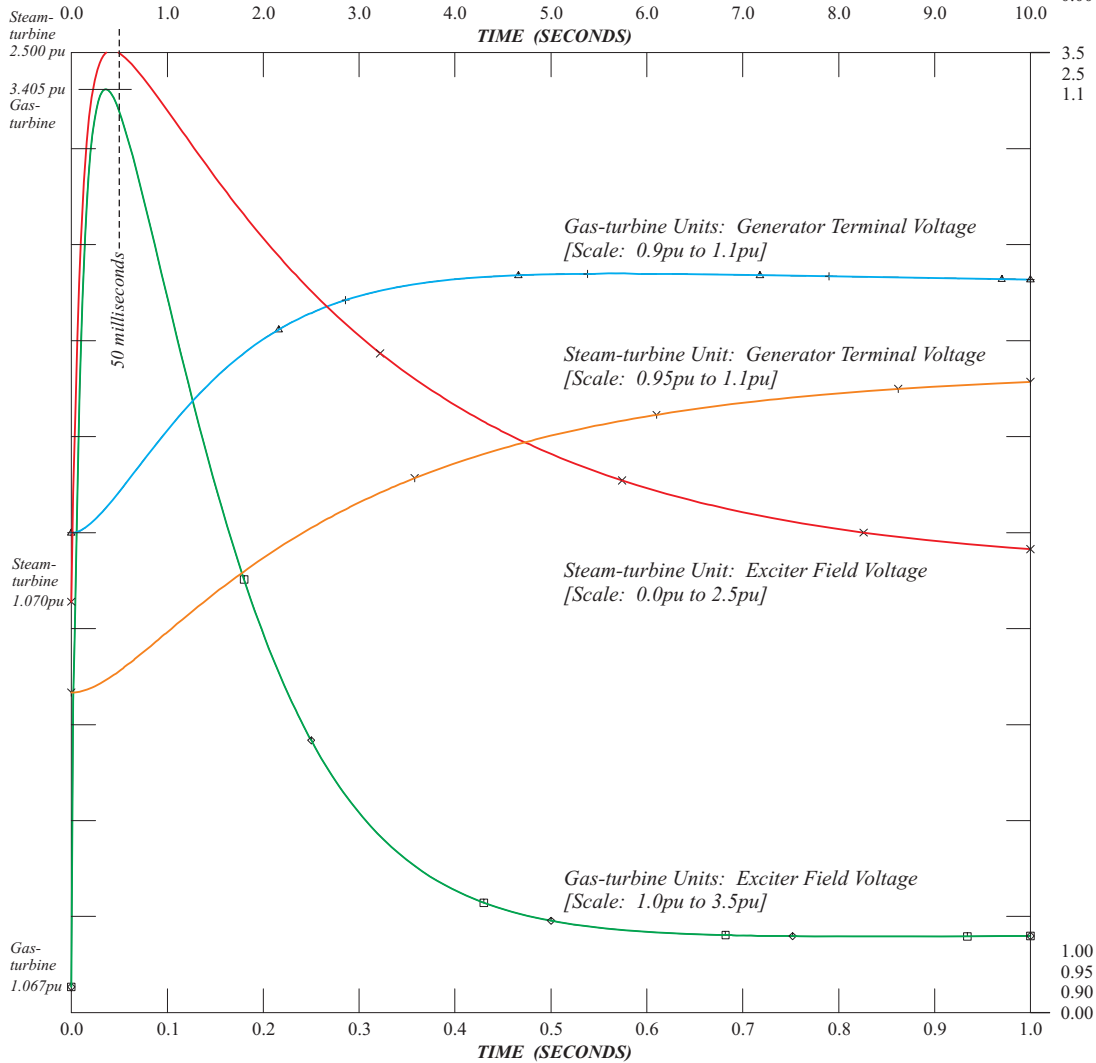
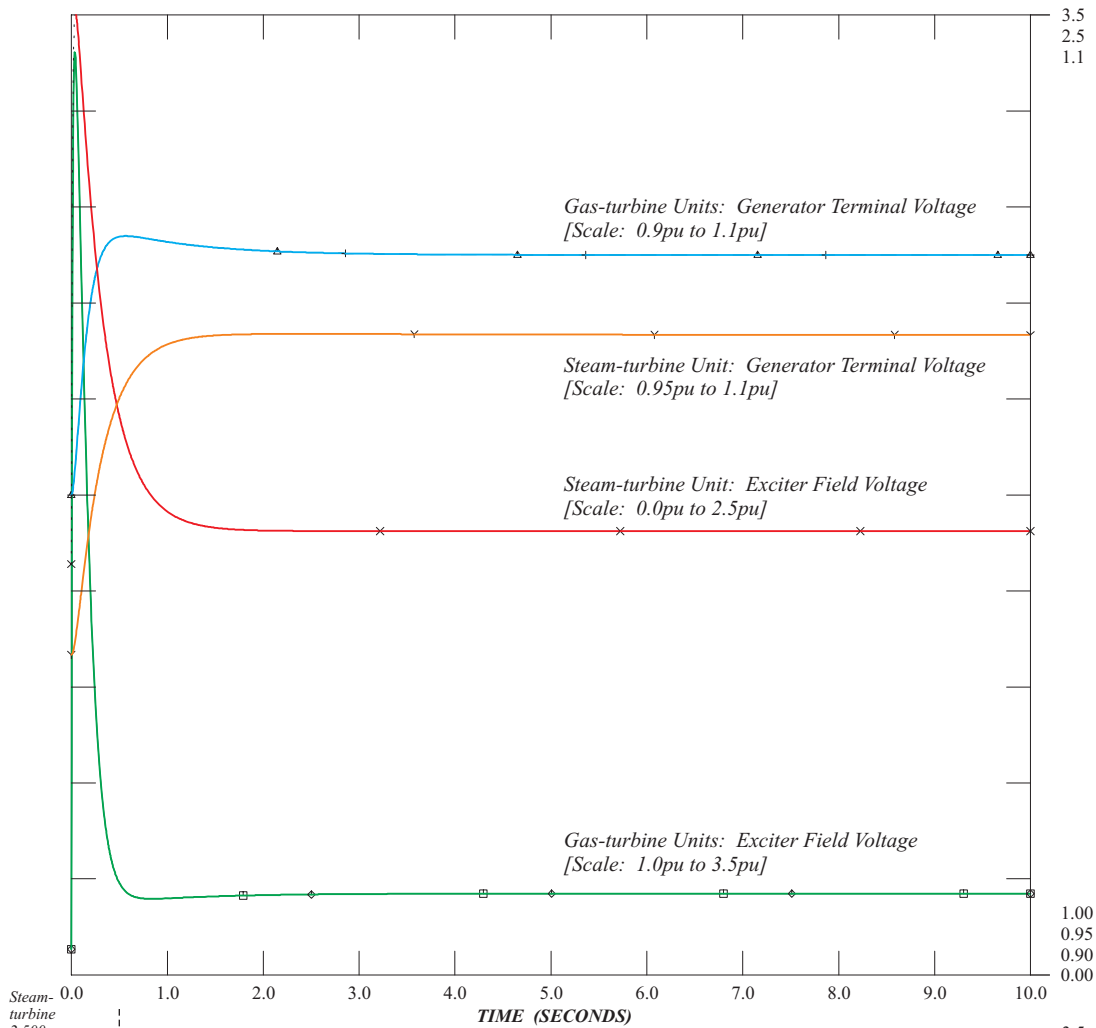

**Portlands Energy Centre
Open-Circuit Step-Response**

[to a 5% increase in the
generator terminal voltage]

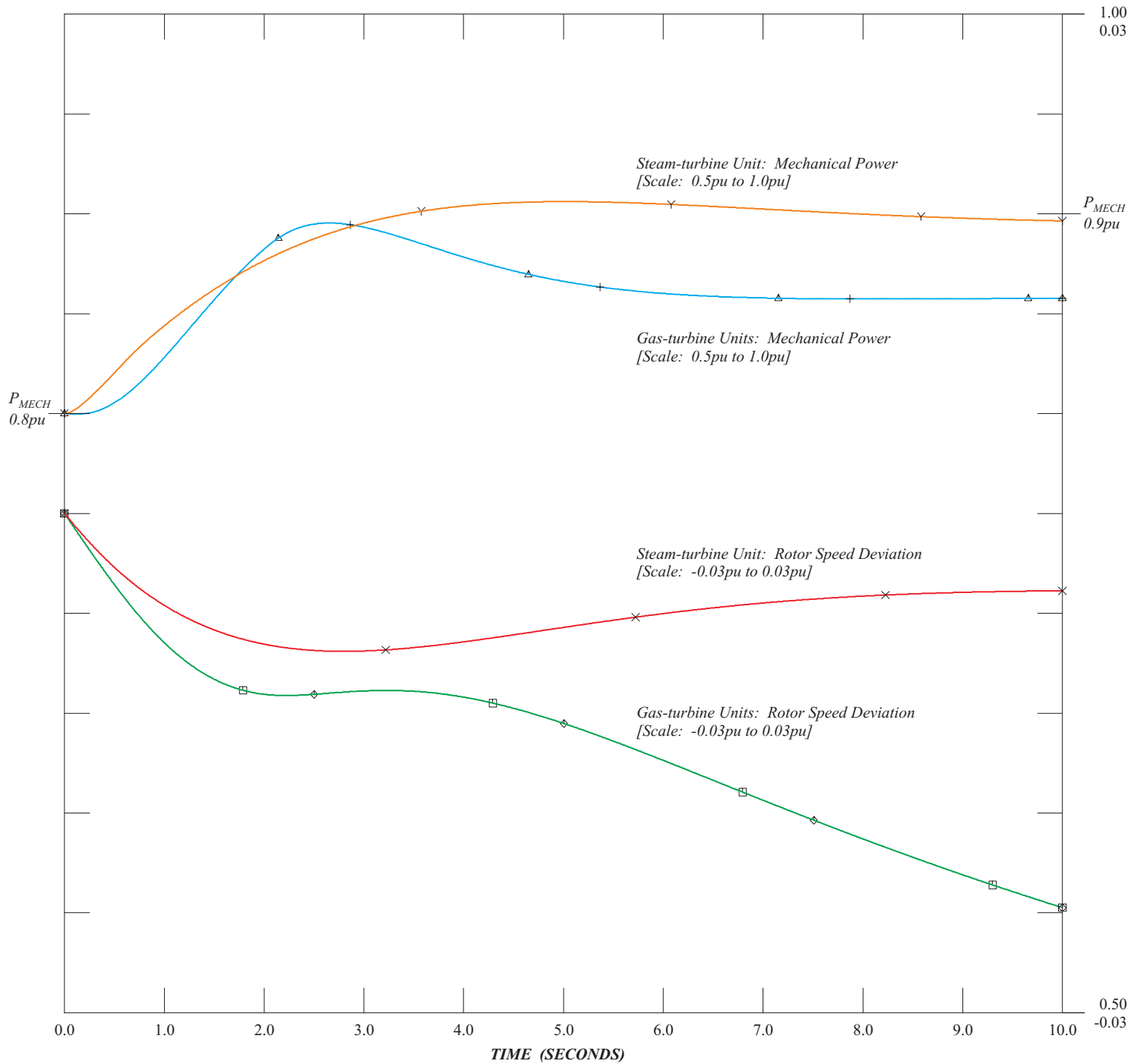

**Portlands Energy Centre
Governor Responses**

DIAGRAM 14

8th October 2007

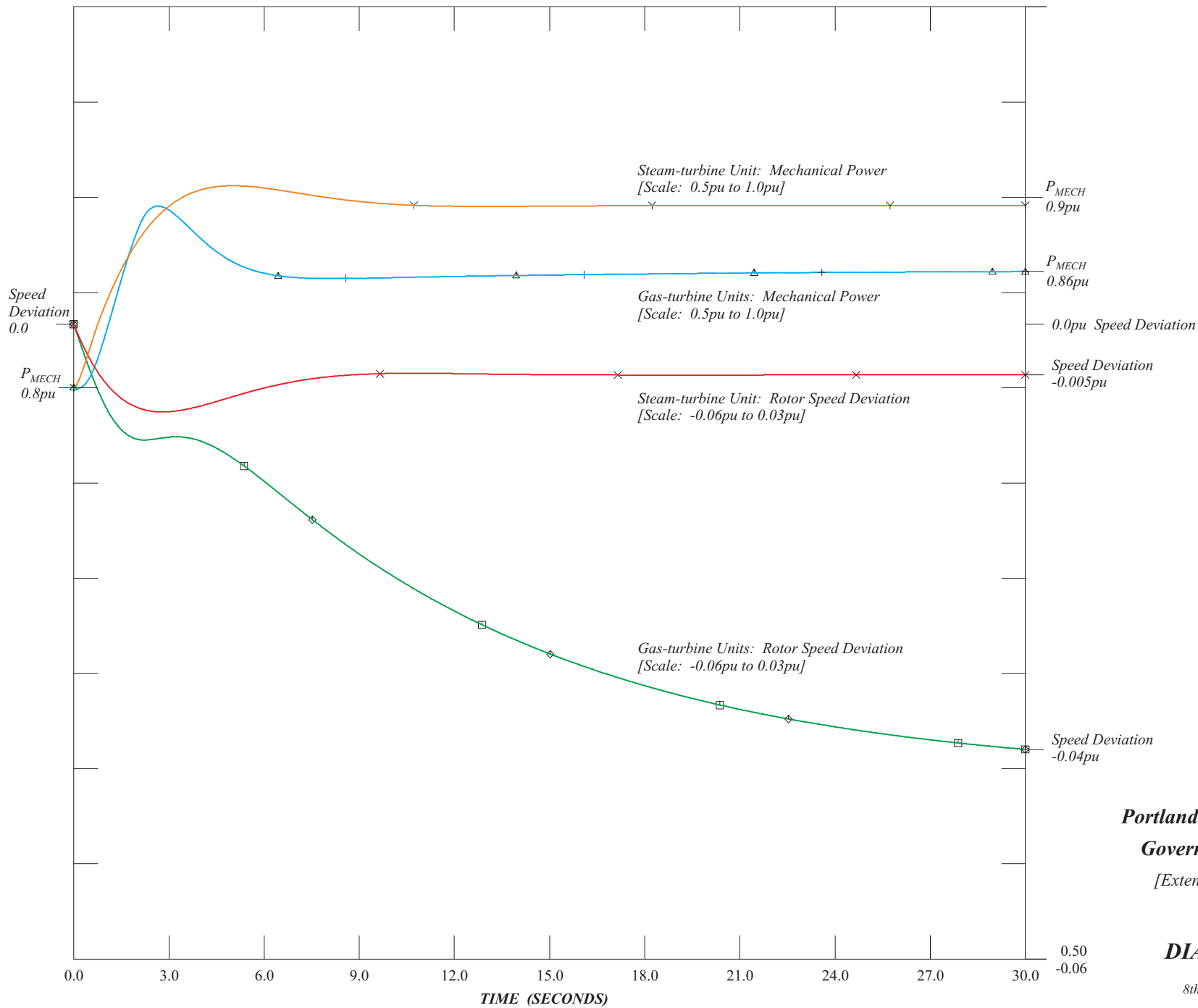

Portlands Energy Centre
Governor Responses
 [Extended time scale]

DIAGRAM 15

8th October 2007

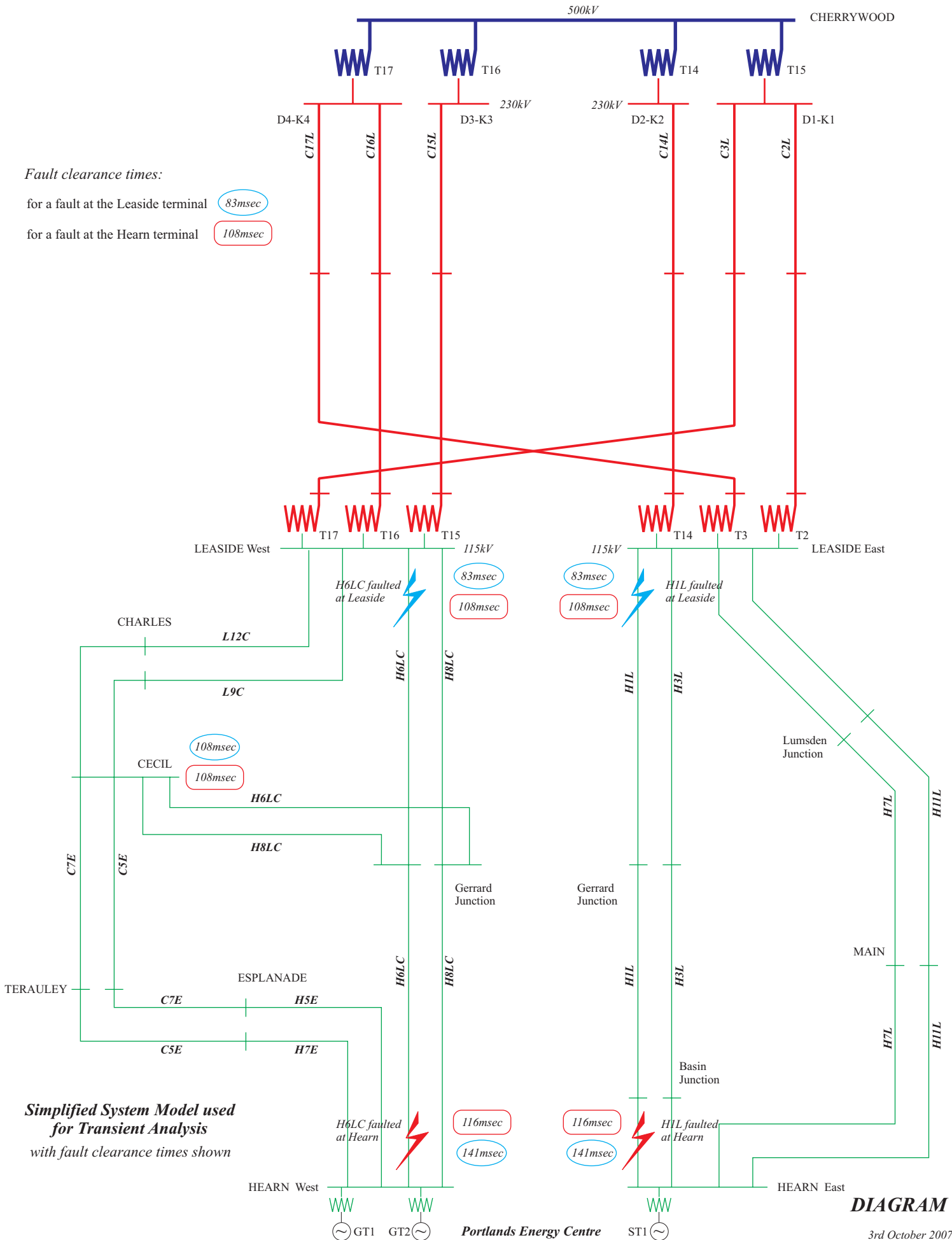
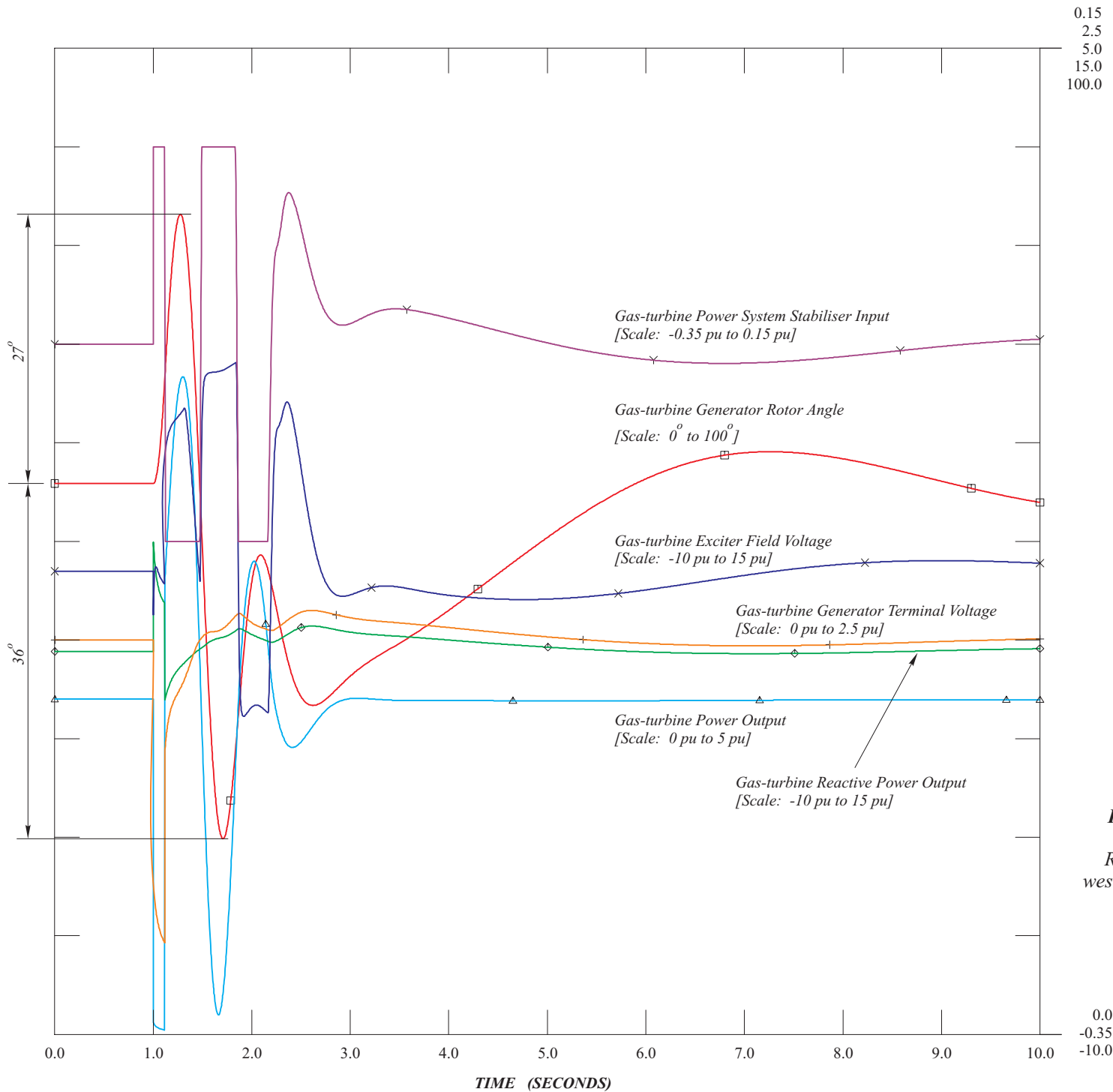
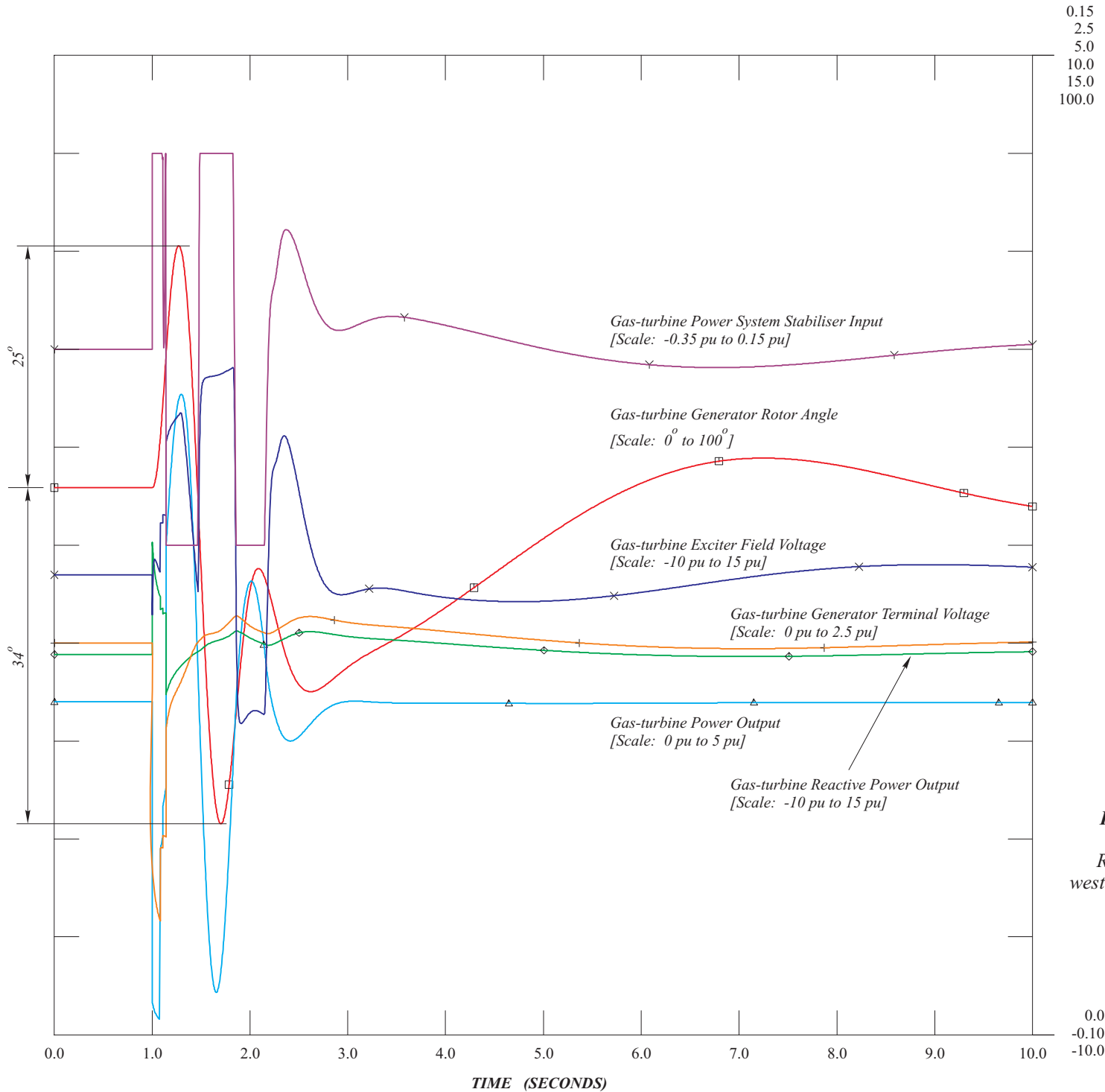

DIAGRAM 16

3rd October 2007



Portlands Energy Centre Project
 Response to a 3-phase fault on the
 western half of the Hearn 115kV busbar



Portlands Energy Centre Project
 Response to a 3-phase fault on the
 western half of the Leaside 115kV busbar

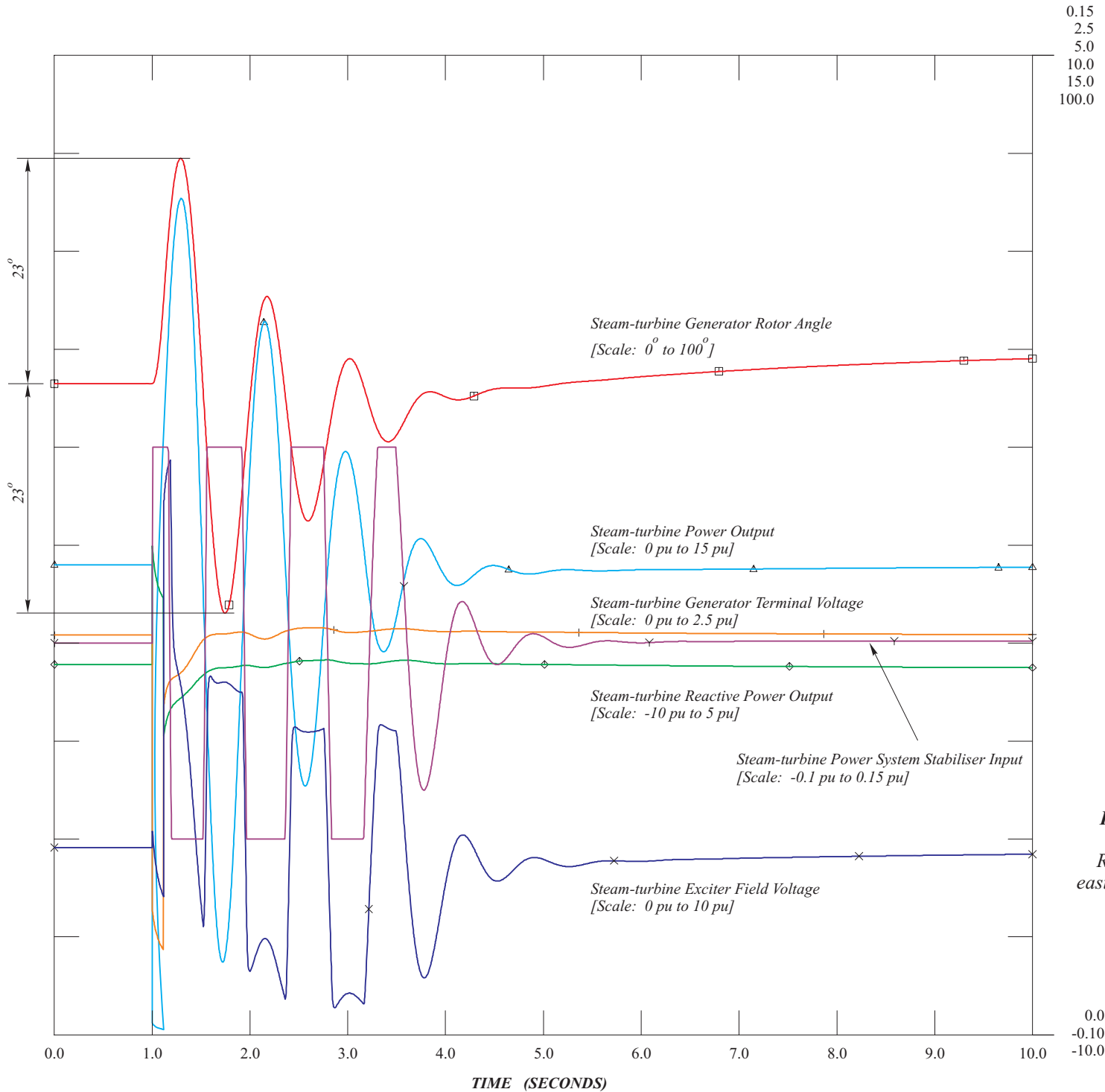

Portlands Energy Centre Project
 Response to a 3-phase fault on the eastern half of the Hearn 115kV busbar

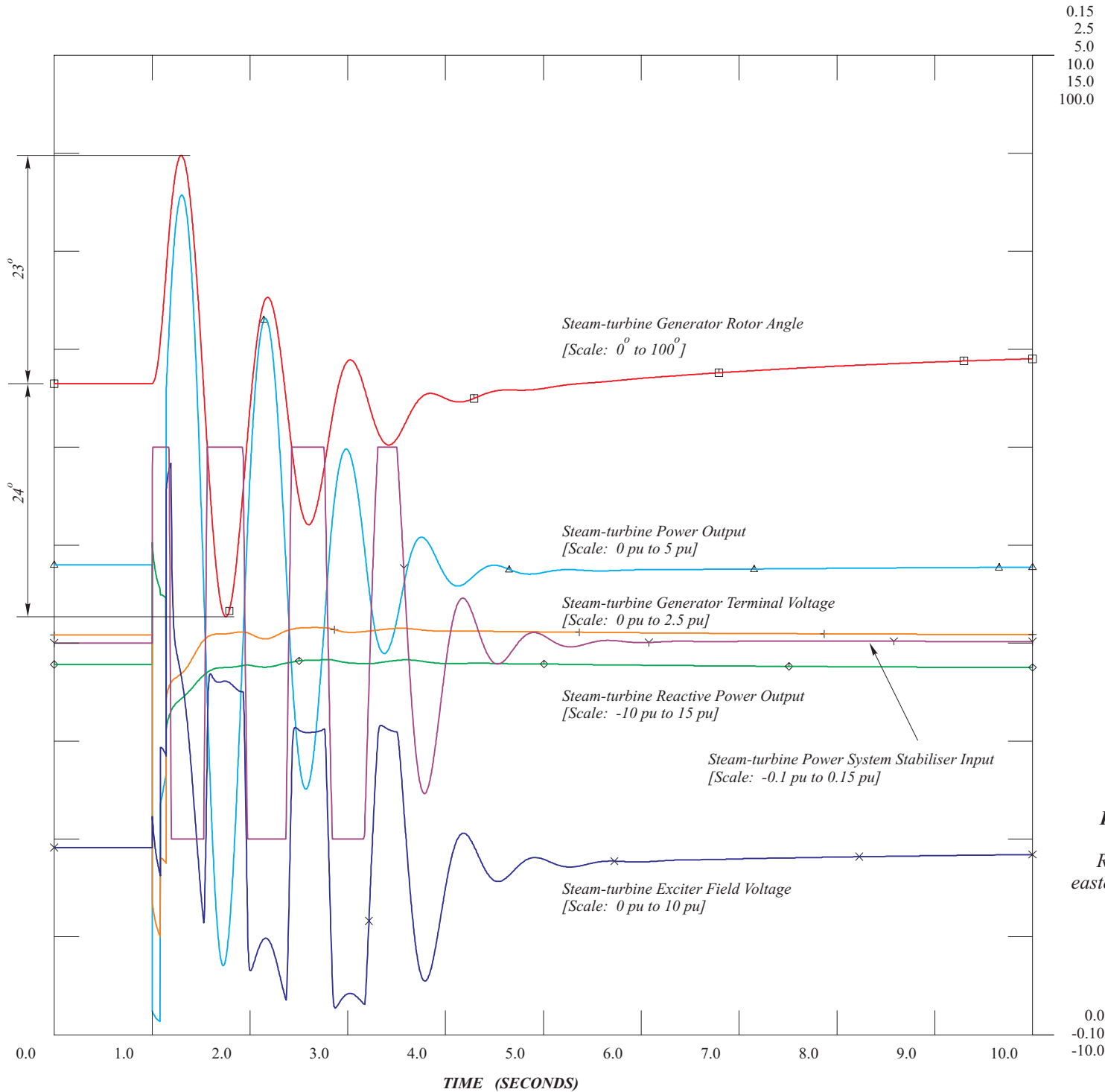

Portlands Energy Centre Project
 Response to a 3-phase fault on the
 eastern half of the Leaside 115kV busbar

DIAGRAM 20

1st October 2007