



18th February 2004

Mr Mel Yates  
Manager – Stations T&D: Sustainment Programs  
Hydro One Networks Inc.  
483 Bay Street  
15th Floor - North Tower  
Toronto M5G 2P5  
Ontario

Dear Mr Yates,

***SARNIA-SCOTT TS - Removal of the Idle 115kV Breaker JL7  
Notification of Approval of the Connection Proposal***

***CAA ID Number: 2004-EX184***

Thank you for the information regarding your proposal to remove the idle 115kV breaker, JL7, from within the 115kV switchyard at Sarnia-Scott TS.

[The approximate location of the breaker is shown in the attached Diagram.]

Since this work involves equipment that is presently unconnected, its removal will have no adverse impact on the IMO-controlled grid.

If the breaker is registered with the IMO, then de-registration will need to be completed through the IMO's 'Facilities Registration' process.

For further information, please contact the undersigned.

Yours truly,

Bob Gibbons  
Manager – Long Term Forecasts & Assessments  
cc: IMO Records

All information submitted in this process will be used by the IMO solely in support of its obligations under the Electricity Act, 1998, the Ontario Energy Board Act, 1998, the Market Rules and associated policies, standards and procedures and in accordance with its licence. All information submitted will be assigned the appropriate confidentiality level upon receipt.

*SARNIA-SCOTT TS*

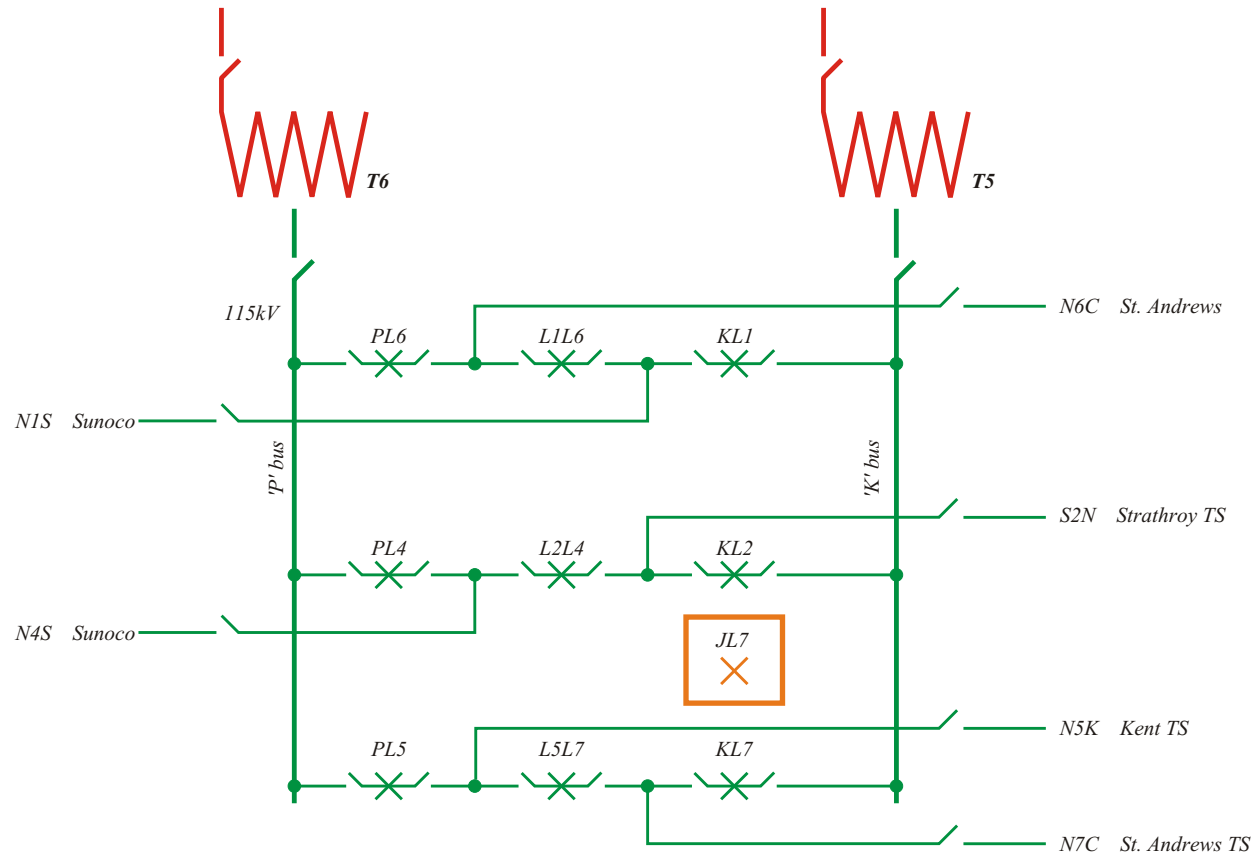

*Approximate Location of Idle 115kV Breaker*