



CONNECTION ASSESSMENT & APPROVAL PROCESS

ASSESSMENT SUMMARY

Applicant: Hydro One Networks Inc.

*Project: Installation of series reactors on the SC1 & SC2 13.8kV
Capacitor Banks at Leaside TS*

CAA ID No. 2003-EX126

***Long Term Forecasts & Assessments Department
Consistent Information Set Department***

Date: 15th April 2003

ASSESSMENT SUMMARY

HYDRO ONE NETWORKS Inc.

LEASIDE TS - Install Series Reactors on the SC1 & SC2 Capacitor Banks

1.0 GENERAL DESCRIPTION

Back-to-back arrangements of capacitor banks can result in high in-rush currents in response to the high frequency interchange of currents between the two banks upon energisation of the second capacitor bank when one capacitor bank is already in-service.

The recommended method of reducing the in-rush currents is to install current-limiting series reactors in each phase of the connection to the individual capacitor banks.

Hydro One is proposing to install series reactors in the connections of the two 13.8kV 15MVA_r shunt capacitor banks, SC1 & SC2, at Leaside TS.

The scheduled completion date for this work is 1st November 2003.

2.0 PROPOSED FACILITIES

The existing arrangement of the two 13.8kV capacitor banks, SC1 & SC2, at Leaside TS is shown in Diagram 1.

The location of the two sets of series reactors that it is proposed to install is shown in Diagram 2.

Specification for the Series Reactors

Type	Air-cored - one per phase
Rating at 60Hz	0.5mH per phase
Rated voltage	13.8kV
Maximum operating voltage	14.6kV continuous
Continuous current	600A rms
Symmetrical short-circuit rating	20kA for 0.5 seconds (30 cycles)
Asymmetrical short-circuit rating	56kA peak
Insulation level (minimum)	110kV BIL
Estimated In-rush Current (with reactors)	3.7kA peak at 467Hz for back-to-back switching
Estimated Out-rush Current (with reactors)	7.16kA peak at 450Hz

3.0 ASSESSMENT

The installation of these series reactors and the subsequent reduction in the in-rush and out-rush currents would reduce the duty imposed on each of the capacitor breakers and limit the possibility that they could malfunction.

This work is therefore considered to be beneficial and will have no negative impact on the IMO-controlled grid.

4.0 CUSTOMER IMPACT ASSESSMENT

Since this work will have no impact on local customers or their facilities, Hydro One has notified the IMO that a Customer Impact Assessment will not be required for this Project.

5.0 NOTIFICATION OF APPROVAL

It is therefore recommended that a Notification of Approval of the Connection Proposal be issued.

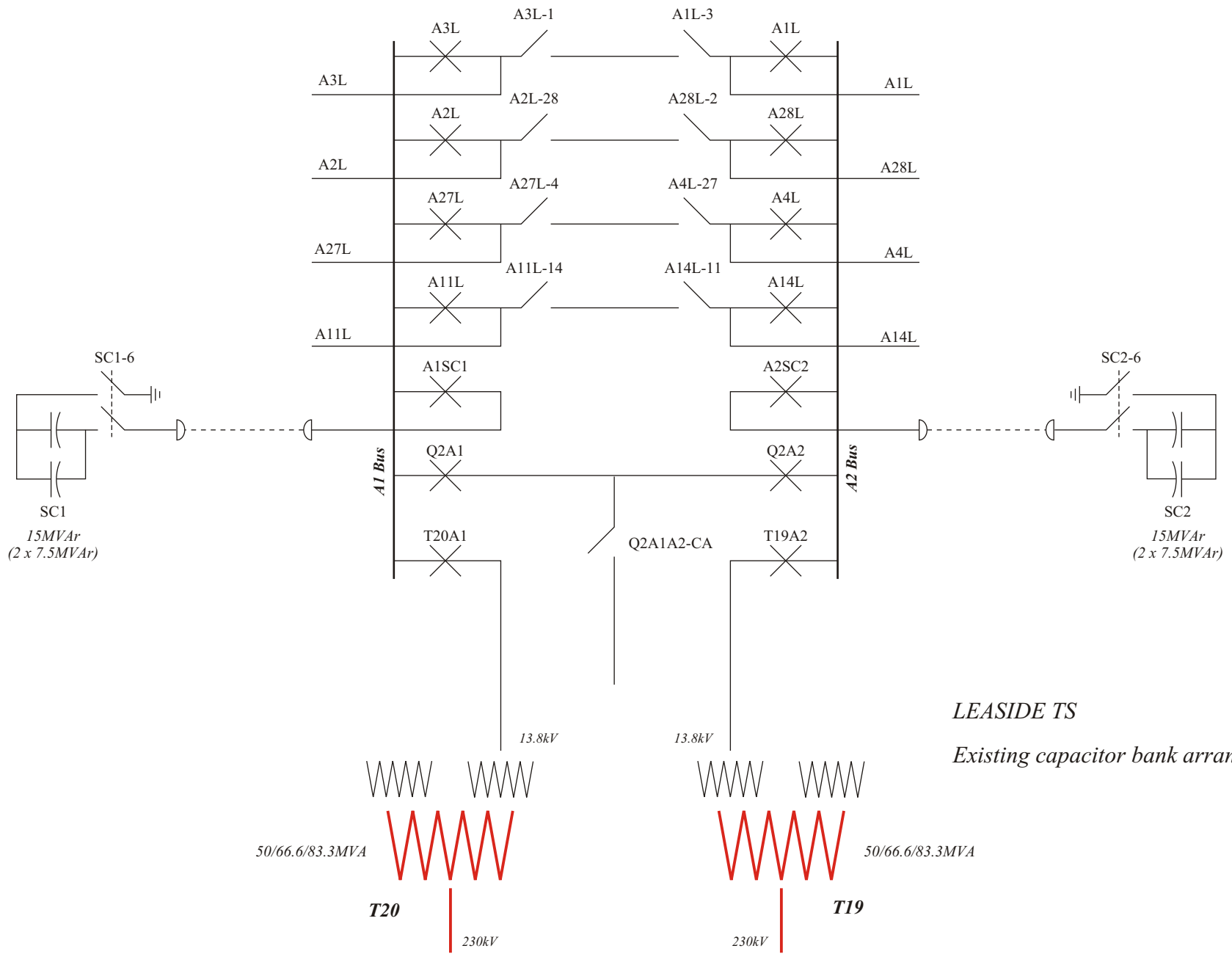

LEASIDE TS
Existing capacitor bank arrangement

DIAGRAM 1

14th April 2002

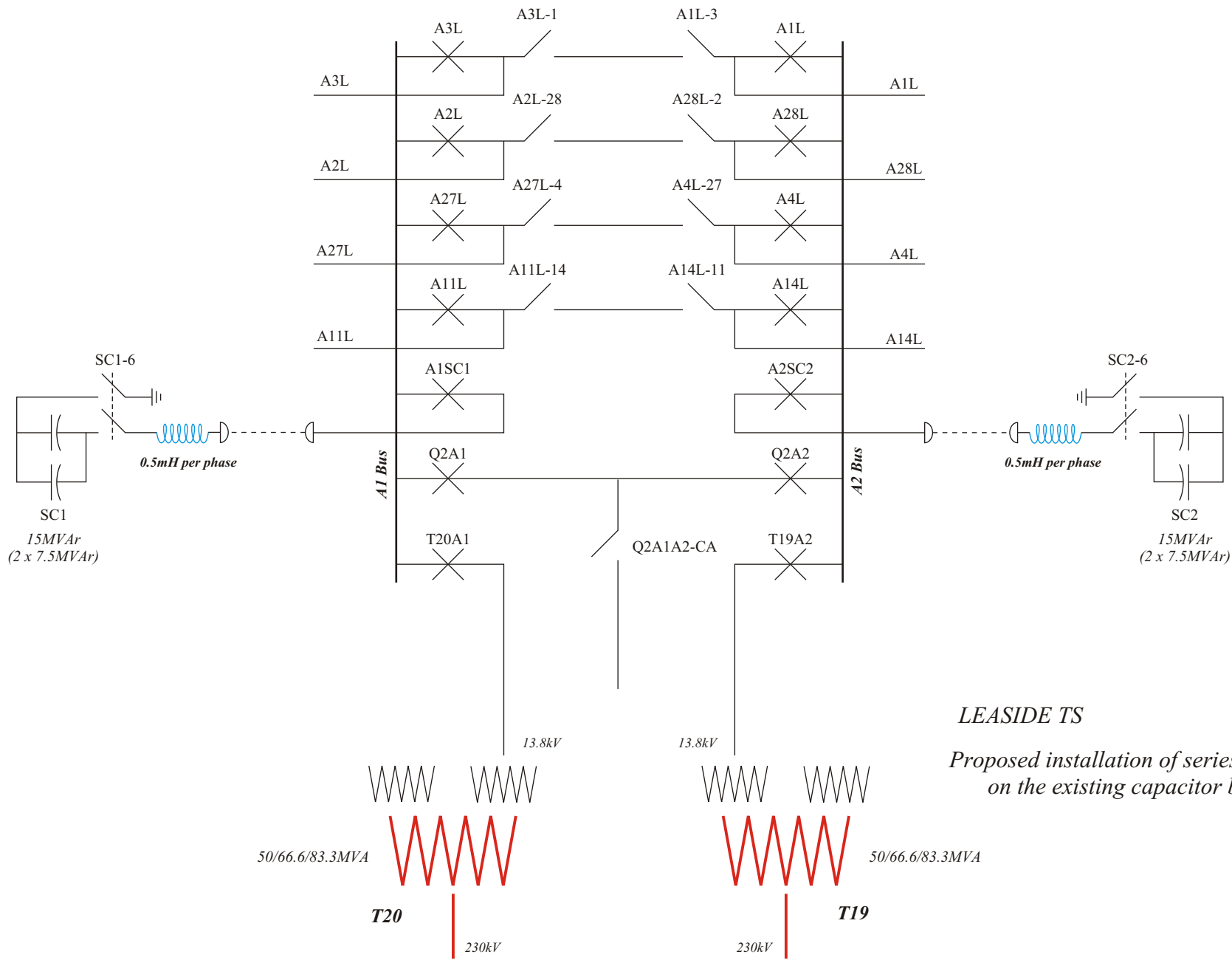

LEASIDE TS

*Proposed installation of series reactors
on the existing capacitor banks*

DIAGRAM 2

14th April 2002