

Final Draft Report
Expedited System Impact Assessment
Hydro One Networks Inc.

1 GENERAL DESCRIPTION

Alliston TS consists of T3 and T4, which form a DESN station supplied via the 230 kV circuits E8V and E9V which run between Orangeville TS and Essa TS. The existing configuration is shown in Figure 3.

Failed transformer T3 at Alliston TS is scheduled to be replaced with a system spare by August 25, 2008.

2 PROPOSED MODIFICATION

A comparison of the technical specifications between the failed and the replacement transformers is given in the following table.

Alliston TS	Failed T3 (NAC9T3)	Existing T4 (NAC9T4)	New T3 (system spare)
Configuration	Three phase	Three phase	Three phase
Transformation (kV)	215.5/44.0	215.5/44.0	215.5/44.0
Winding Configuration	Wye/wye	Wye/wye	Wye/wye
Thermal Rating	50 MVA ONAN 66.7 MVA ONAF 83.3 MVA ONAF	50 MVA ONAN 66.7 MVA ONAF 83.3 MVA ONAF	50 MVA ONAN 66.7 MVA ONAF 83.3 MVA ODAF
Continuous Thermal Rating (summer 30°C)	83.3 MVA	83.3 MVA	83.3 MVA
15-MIN Thermal Rating (summer 30°C)	132.7 MVA	132.7 MVA	166.6 MVA
10-DAY Thermal Rating (summer 30°C)	99.9 MVA	99.9 MVA	112.3 MVA
Positive Sequence Impedance (H-X)	R = 0.27 % X = 9.73 % on 50 MVA base	R = 0.26% X = 9.81 % on 50 MVA base	R = 0.27 % X = 9.84 % on 50 MVA base
Impedance to Ground	Solidly grounded	Solidly grounded	Unknown
Under-load tap-changer	220 ± 40 kV 32 Steps	220 ± 40 kV 32 Steps	215.5 ± 40 kV 32 Steps
Off-load tap-changer	N/A	N/A	N/A
In service off-load tap position	N/A	N/A	N/A
Manufacturer	CGE	CGE	CGE

Table 1 – Comparison of Failed and Replacement Transformers T3 and T4

3 ASSESSMENT

3.1 Replacement Transformers

The information provided by Hydro One Networks Inc. shows that the technical characteristics of the replacement transformer are similar to those of the existing T4. The positive sequence impedance of the new transformer is slightly higher than the failed transformer's impedances but this does not represent a concern since the difference is small.

The replacement transformer will have a ULTC providing a secondary voltage range as shown below. The range is slightly different than the ULTC range of the failed transformer but does not represent a concern.

	Failed T3	Existing T4	New T3
Under-load tap-changer (ULTC)	180 - 260 kV	180 - 260 kV	175.5 - 255.5 kV

Table 2 – Secondary Voltage Ranges for Failed and the Replacement Transformers

3.2 Station 10-Day Summer Capabilities

The 10-DAY summer capability for the T3/T4 station is determined by the removing the transformer with the largest 10-DAY thermal rating from service. The 10-DAY summer ratings of the two transformers at Alliston TS are listed in the table below.

For the T3/T4 station, the existing 10-DAY summer capability with T3 out of service is 99.9 MVA. With the replacement T3 installed, the T3/T4 10-DAY summer capability will still be 99.9 MVA, as shown in the table below.

Summer Ratings for Transformers T3 and T4		
Transformer	10-DAY Thermal Rating (MVA) (summer 30°C)	
	Prior to replacement of T3	After replacement of T3
T3	O/S (99.9)	O/S (112.3)
T4	99.9	99.9
T3/T4 Station Summer 10-DAY Capability (with highest rated transformer out of service)	99.9	99.9

Table 3 – 10-DAY Thermal ratings (summer) for transformers T3 and T4

3.3 LOAD PEAKS AND PROJECTIONS

The 2007 peak load for T3/T4 at Alliston TS of 123.5 MVA occurred on August 2, 2007 at 16:00. Figure 1 shows the loading at the LV side of T3/T4. The 2007 peak load on T3/T4 exceeded the T3/T4 station's 10-DAY summer capability of 99.9 MVA by 23.6 MVA.

Hydro One built a new transformer station to alleviate Alliston TS overloads and to help supply the area load. The new Everett TS, with a 10-DAY summer capability of 112.8 MVA, was placed in service on October 10, 2007. The CAA report for Everett TS can be seen at [2006-227](#).

**Alliston TS – Replacing Failed T3
CAA ID # 2008-EX399**

It can be seen that Alliston TS T3/T4 loads have decreased since Everett TS was installed. The 2008 peak load of 104.3 MVA occurred on January 3, 2008 at 19:00.

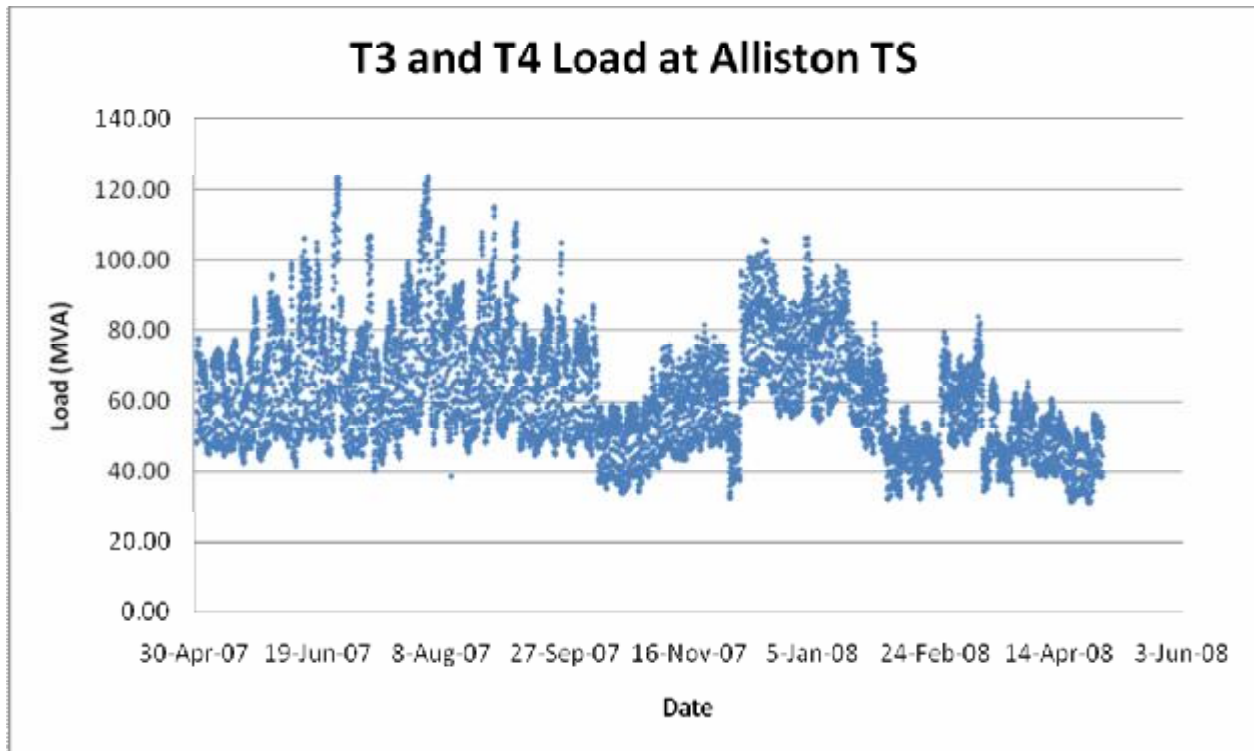

Figure 1 Alliston TS T3 and T4 Load

The projected loads at both Alliston TS and Everett TS are shown in Table 4 below. The load at Alliston TS will be maintained close to its 10-DAY summer capability of 99.9 MVA. The projected load at Everett TS is well below its 10-DAY summer capability.

Projected Peak Loads				
	Alliston T3/T4 Station		Everett TS	
Year	assuming 1% growth rate	10-DAY summer capability	assuming 1% growth rate	10-DAY summer capability
2007	123.5 MVA (actual)	99.9 MVA	-	-
2008	99.9 MVA		24.7 MVA	112.8 MVA
2009	99.9 MVA		26.0 MVA	
2010	99.9 MVA		27.2 MVA	
2011	99.9 MVA		28.5 MVA	
2012	99.9 MVA		29.8 MVA	
2013	99.9 MVA		31.1 MVA	
2014	99.9 MVA		32.4 MVA	

Table 4 – Alliston TS and Everett TS Projected Load Growth

3.4 Line Taps

The E8V and E9V line taps from T3 and T4 at Alliston TS have a summer continuous rating of 1260 A (501.9 MVA) at 230 kV (35°C, 4 km/h wind speed). These line taps are more than adequate to supply the near term load growth that would occur at Alliston TS.

3.5 Power Factor

Operational information from May 2007 through May 2008 was used to calculate the power factor at Alliston TS T3/T4. Figure 2 illustrates the power factor at the LV side of T3/T4. Alliston TS is not equipped with shunt capacitors.

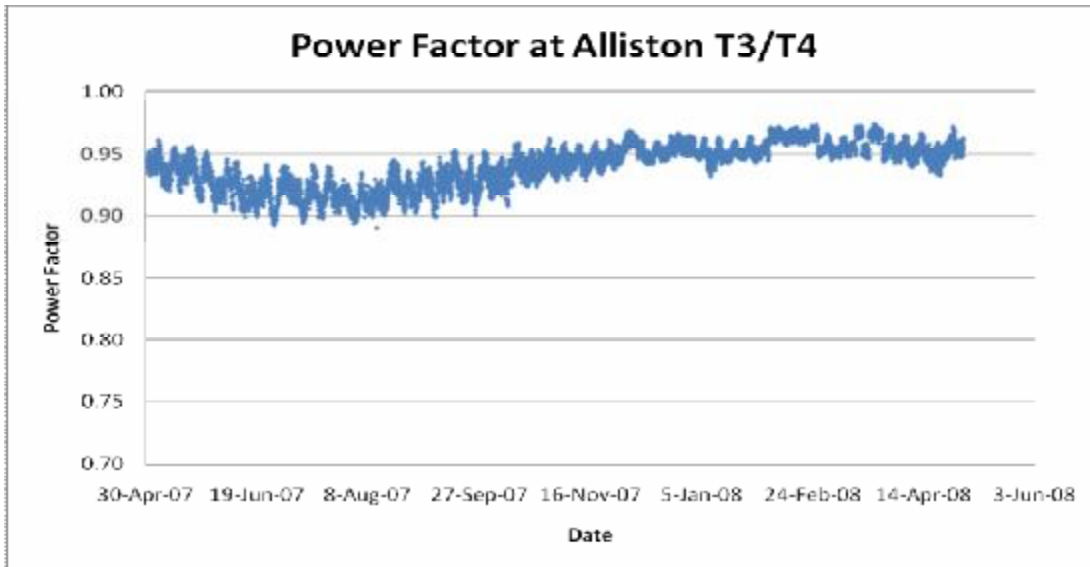

Figure 2 Power Factor at Alliston TS T3/T4

The Market Rules require operation at a power factor range of 0.9 lagging to 0.9 leading. Between May 2007 and May 2008, the lowest power factor at Alliston TS T3/T4 of 0.89 occurred on August 12, 2007 at 06:00. The power factor as calculated on the high side at that time was 0.88 lagging.

The actual values at the low voltage side were as follows:

Date	Time	T3 P (MW)	T3 Q (MVAR)	T4 P (MW)	T4 Q (MVAR)	P Total (MW)	Q Total (MVAR)	LV PF	HV pF (calculated)
August 12, 2007	06:00	-16.71	-8.59	-17.47	-8.90	-34.19	-17.49	0.89	0.88

Table 5 – Alliston TS T3/T4 at Lowest Power Factor

Power factor correction was deemed necessary at Alliston TS during the IESO assessment of Everett TS. To meet the load power factor requirement for a load not exceeding 100 MVA, 14 MX of LV shunt capacitors were required to be installed at Alliston TS. Complete details can be found at [2006-227](#).

4 CONCLUSIONS

It can be concluded that the replacement of T3 at Alliston TS will not result in a material adverse effect on the reliability of the IESO-controlled grid because:

- § the load at Alliston TS will be maintained close to the T3/T4 station 10-DAY summer capability;
- § the voltage range provided by the ULTC for the replacement of T3 is similar to the ULTC voltage range of the existing T4;
- § the positive sequence impedance for the replacement T3 is slightly higher than the positive sequence impedance of the failed T3 but similar to the positive sequence impedance of the existing T4.

5 REQUIREMENTS

Hydro One must notify the IESO as soon as it becomes aware of any changes to the assumptions made in the connection assessment. The IESO will determine whether these changes require a re-assessment.

Hydro One is required to meet the requirements with respect to protection systems for the new transformer and coordination with the existing protection systems, as outlined in the Transmission System Code.

The Market rules (Chapter 4 section 7.4) require that transmitter shall provide the IESO on a continual basis with on-line monitored quantities as specified in Appendix 4.16. For this proposed project, the IESO will continue to require the operating quantities associated with the new transformer.

Power factor correction of 14 MX is required at T3/T4.

6 NOTIFICATION OF APPROVAL

It is therefore recommended that a Notification of Approval of the Connection Proposal be issued subject to the implementation of the requirements listed in section 5.0.

Alliston TS – Replacing Failed T3
CAA ID # 2008-EX399

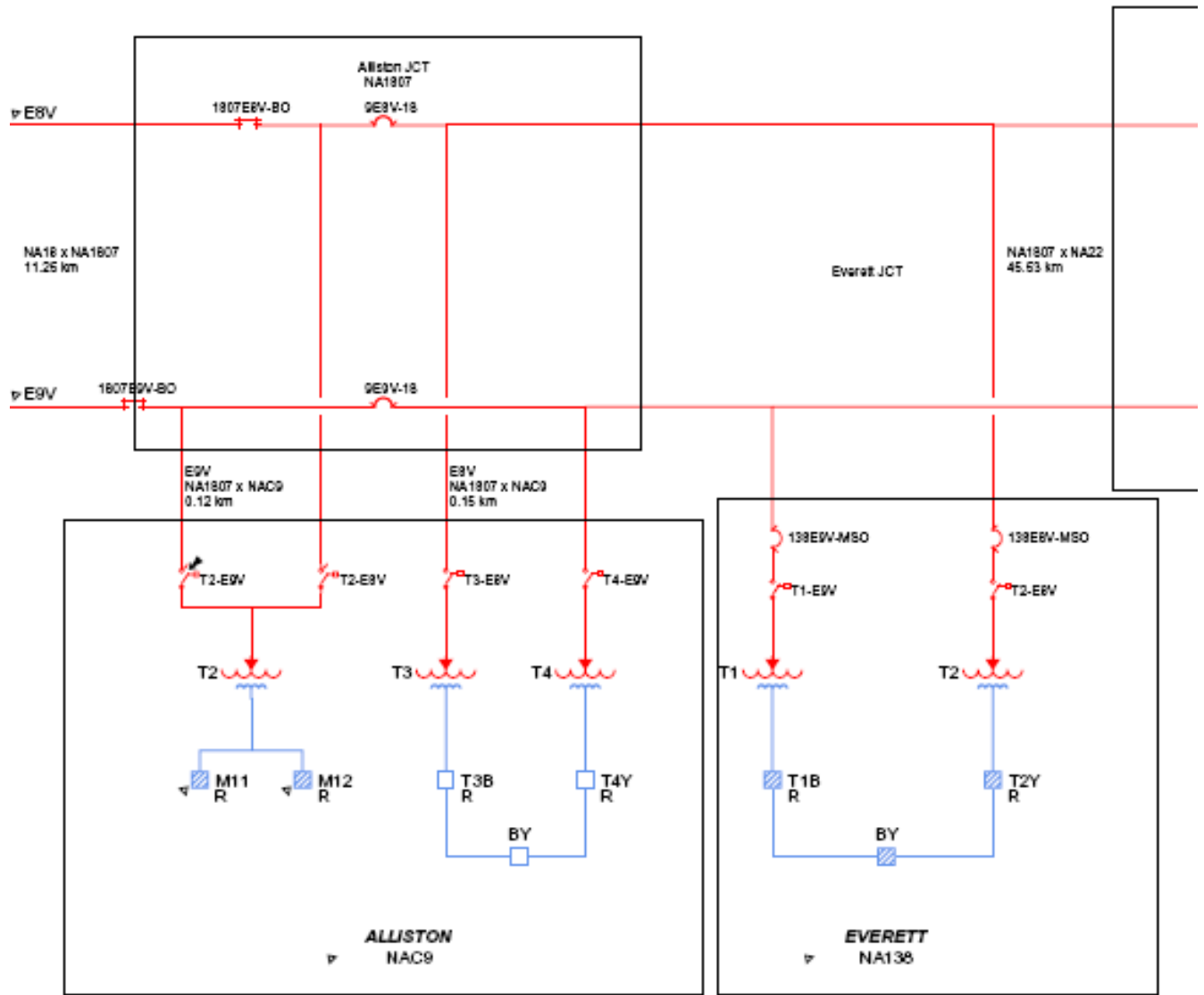

Figure 3: Alliston TS Station Operating Diagram