



August 7, 2003

Mr. Mel Yates
Manager, Stations, T&D Sustainment Programs
Investment Planning Division
Hydro One
483 Bay Street
Toronto, Ontario, M5G 2P5

Dear Mr. Yates:

***Replacement of Failed Essex Transformer T4
Notification of Approval of Connection Proposal
CAA ID Number: 2003-EX144***

Thank you for the detailed information that you provided on the plan to replace the failed transformer T4 at Essex TS. Hydro One proposes to replace the failed unit T4 with the existing T3 bank, which has been disconnected since year 2000 due to reduced station load. The two transformers are of the same vintage and identically rated.

Hydro One plans to reconnect T3 to the HV bus via its own high voltage disconnect switch, and to provide the LV connection via the existing T4B breaker, as shown in Figure1 attached. The T4 grounding transformer (T4GT) will be retained and the T3 data points will be re-wired to T4 points.

We have reviewed the data and concluded that this project can be classified as a "like-for-like" replacement because the new transformer has similar impedance and capability as the old transformer and will have no adverse impact on the system reliability. Hence, a formal Connection Assessment Study is not warranted.

The IMO is therefore pleased to grant approval to complete the replacement of Essex T4 transformer with the idle unit, T3.

Please note that the new facilities will also have to meet the requirements of the IMO's Facility Registration process before being placed in service.

For further information, please contact the undersigned.

Yours truly,

Bob Gibbons
Manager - Long Term Forecasts & Assessments
Telephone: (905) 855-6482
Fax: (905) 855-6373
E-mail: bob.gibbons@theimo.com

cc: IMO Records

All information submitted in this process will be used by the IMO solely in support of its obligations under the *Electricity Act, 1998*, the *Ontario Energy Board Act, 1998*, the *Market Rules* and associated policies, standards and procedures and in accordance with its licence. All information submitted will be assigned the appropriate confidentiality level upon receipt.

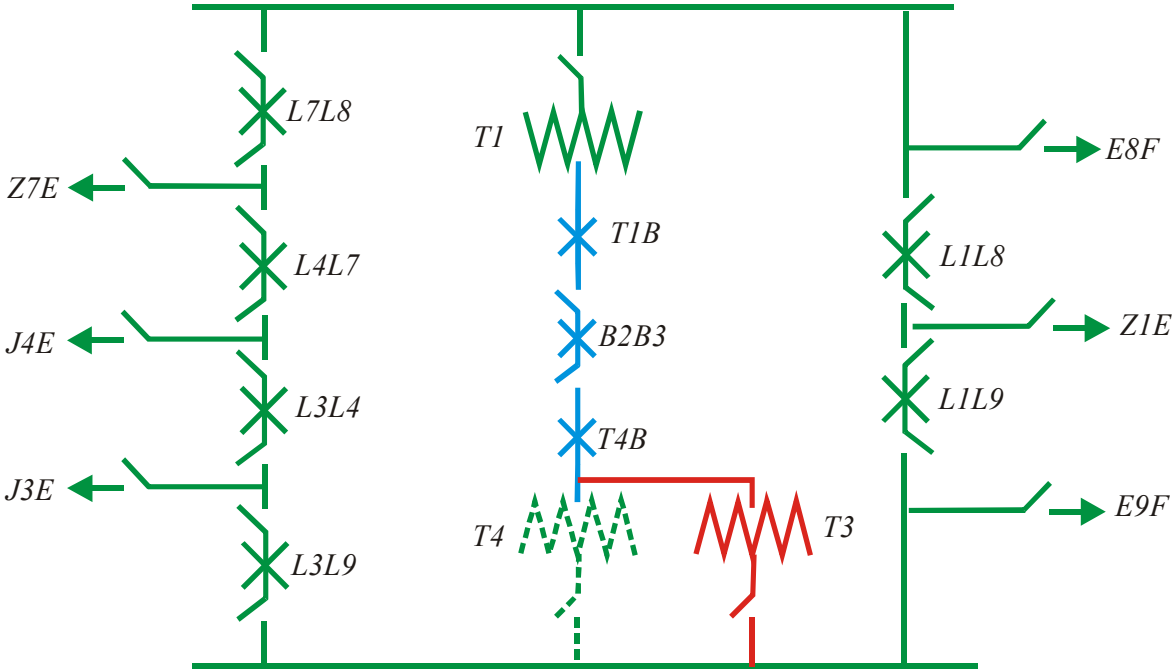
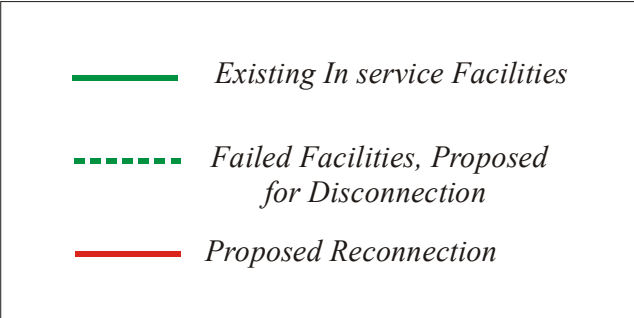

Figure 1. Essex TS - Proposed Modifications