



CONNECTION ASSESSMENT & APPROVAL PROCESS

Connection Assessment Report for Detweiler Shunt Capacitor Replacement

Connection Applicant: Hydro One Networks Inc.

CAA ID 2002-EX032

Final Report

Prepared by
Long Term Forecasts & Assessments Department &
Consistent Information Set Department

May 16, 2002

1.0 Project Description

Hydro One Network Inc. has submitted a connection assessment application for installation of one new 230 kV shunt capacitor connected at Detweiler TS in the 230 kV switch yard. The new capacitor, SC21, will be replacing the existing 192 Mvar bank located between breakers ASC21 and T2SC21.

The shunt capacitor bank is to be connected via a disconnect switch, a current limiting reactor of 0.622 ohms and a synchronizing breaker. A diagram of the proposed connection, with the new facilities shown in red, is presented in Figure 1.

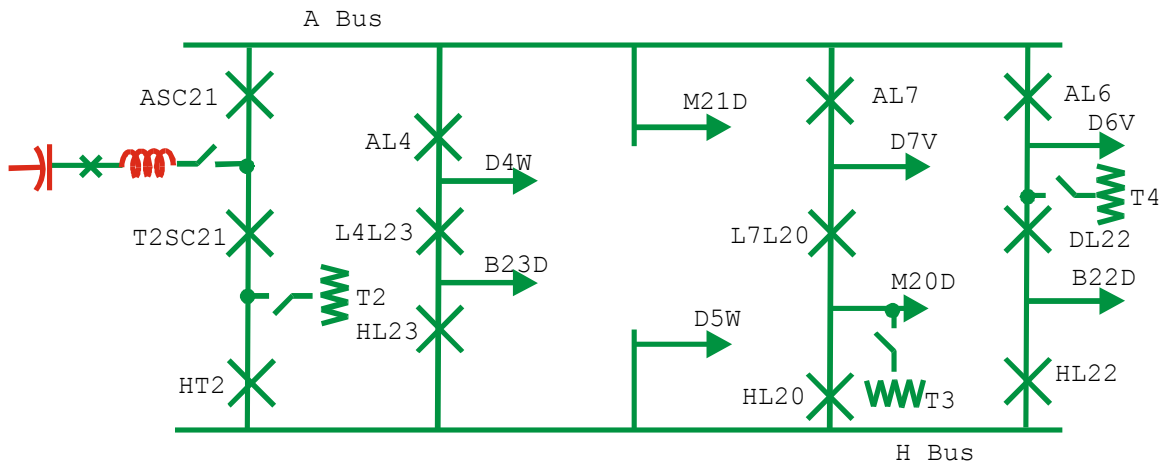

Figure 1. Detweiler TS 230 kV Switch Yard

The new capacitor specifications are:

- 225 Mvar rated at 245 kV
- Operating voltage – 245 kV
- Configuration – Double Wye ungrounded
- Protection – phase overvoltage and neutral unbalance.

The capacitor units are not to be equipped with fast discharge resistors.

The existing SF6 circuit breaker SC21AT will be retained. It is rated for a maximum voltage of 250 kV and a symmetrical interrupting capability of 63 kA, hence considered to be adequate. The breaker is ganged-pole breaker and no special features are provided for synchronized opening or closing.

The new 0.622 ohms per phase current limiting reactor is to be located between the disconnect switch and the breaker and it was sized to ensure that the in-rush currents do not exceed the breakers' interrupting capability.

2.0 Assessment

The Market Rules require that the voltage change upon switching of a capacitor bank not exceed 4%. Calculations, using the system short circuit levels provided by Hydro One from the 1999 short circuit survey, show that the switching of this low voltage capacitor will generate a voltage change of about 2.7%.

Because the capacitor units are not equipped with fast discharge resistors the successive switching off and on of this capacitor bank will have to be restricted to allow for the full discharge of the cans.

Auto switching capability will not be provided for this shunt capacitor installation.

3.0 Conclusions and Recommendations

The proposed installation of the 230 kV shunt capacitor bank at Detweiler TS is not likely to have any adverse impact on the reliability of the IMO-controlled grid.

4.0 Notification of Approval

It is thus recommended that notification of approval be granted for the installation of the 225 Mvar shunt capacitor at Detweiler TS.