



# **CONNECTION ASSESSMENT & APPROVAL PROCESS**

## **ASSESSMENT SUMMARY - ADDENDUM**

**Applicant: Hydro One Networks Inc.**

**Project: Merivale TS  
Replace 115kV Oil Breakers L1L5, L1LT22,  
and L3L12, and Associated Breaker  
Disconnect Switches**

**CAA ID: 2002 – EX109**

**Long Term Forecasts & Assessments Department  
Consistent Information Set Department**

**Date: April 7, 2003**

## 1.0 Introduction

In late 2002, Hydro One Networks Inc. submitted a connection assessment application for the replacement of three existing 115kV 1,200A 20.2kA bulk oil circuit breakers with new 145kV 2,000A SF<sub>6</sub> circuit breakers that have an interrupting capability of 50kA.

The application was assessed under CAA 2002 – EX109. Assessment Summary and Notification of Approval for the project were issued on March 6, 2003.

Hydro One Network Inc. has advised the IMO that instead of breakers with 50kA interrupting capability as originally proposed, the new SF<sub>6</sub> breakers will have an interrupting capability of 40kA. The applicant is therefore requesting approval for the revision to the project.

## 2.0 Assessment

Presently, there are a total of sixteen 115kV breakers at Merivale TS. Eight of the sixteen breakers have a 20.2kA symmetrical fault current interrupting capability, while the remaining breakers have a minimum 39.3kA interrupting capability.

Merivale TS is presently operating with the 115kV bus split to limit the maximum 115kV short circuit level below 20kA. The maximum 115kV short circuit level would increase to about 26kA, if the station were operating with a solid 115kV bus and the proposed interconnection with Hydro Quebec were in-service.

The proposed 40kA SF<sub>6</sub> breakers would be adequate and would not adversely affect the reliability of the IMO-controlled grid.

However, it should be noted that even though the replacement breakers would be adequate, they do not comply with the Transmission System Code requirement of having maximum fault interrupting capability of 50kA for 115kV breakers. Should a third party initiate a development that increases the fault level at Merivale TS 115kV bus beyond the capability of the replacement breakers, then Hydro One Networks Inc. would be expected to bear the cost of having to replace these breakers again.

## 3.0 Recommendation

Based on the above assessment, it is recommended that approval for the revision be granted to the applicant.



# **CONNECTION ASSESSMENT & APPROVAL PROCESS**

## **ASSESSMENT SUMMARY**

**Applicant: Hydro One Networks Inc.**

**Project: Merivale TS**  
**Replace 115kV Oil Breakers L1L5, L1LT22,**  
**and L3L12, and Associated Breaker**  
**Disconnect Switches**

**CAA ID: 2002 – EX109**

**Long Term Forecasts & Assessments Department**  
**Consistent Information Set Department**

**Date: March 6, 2003**

Merivale TS: Replace 115kV Oil Breakers L1L5, L1LT22, and L3L12, and Associated Breaker Disconnect Switches

---

## 1.0 Description of Proposal

Hydro One Networks Inc. is proposing to replace three existing 115kV 1,200A bulk oil circuit breaker with 20.2kA symmetrical fault current interrupting capability and their associated 1,200A disconnect switches with new 145kV SF<sub>6</sub> circuit breakers and new 138kV disconnect switches. The breakers and disconnect switches that are to be replaced are identified in Figure 1.

The replacement breakers and disconnect switches are rated as follows:

### Circuit Breaker

Rated Voltage (kV):	145
Continuous Current (A):	2,000
Interrupting Capability (kA):	50
Interrupting Media:	SF <sub>6</sub>

### Disconnect Switch

Rated Voltage (kV):	138
Continuous Current (A):	2,000
Momentary Current (kA):	63

The proposed work is scheduled for completion in the fourth quarter of 2003 under the proponent's 2003 Breaker Replacement Program.

## 2.0 Assessment

Merivale TS has a total of sixteen breakers. Twelve breakers are oil breakers and four are SF<sub>6</sub> breakers. Eight of the twelve oil breakers are 115kV 1,200A units with 20.2kA symmetrical fault current interrupting capability. The remaining four oil breakers are 138kV 1,600A units with 39.3kA interrupting capability.

The proponent is proposing to replace three of the eight 115kV 1,200A 20.2kA oil breakers and their associated disconnect switches with new SF<sub>6</sub> breakers and disconnect switches of higher ratings. Although the new breakers have higher ratings than the existing units and are definite improvement, Merivale TS fault level rating remains at 20kA as defined by the remaining 20.2kA oil breakers.

This proposal is essentially a like-for-like replacement of existing facilities and would not have any adverse impact on the operating reliability of the IMO-controlled grid.

## 3.0 Notification of Approval

Based on the above assessment, it is recommended that a Notification of Approval for this proposal be issued to the applicant.

Merivale TS: Replace 115kV Oil Breakers L1L5, L1LT22, and L3L12, and Associated Breaker Disconnect Switches

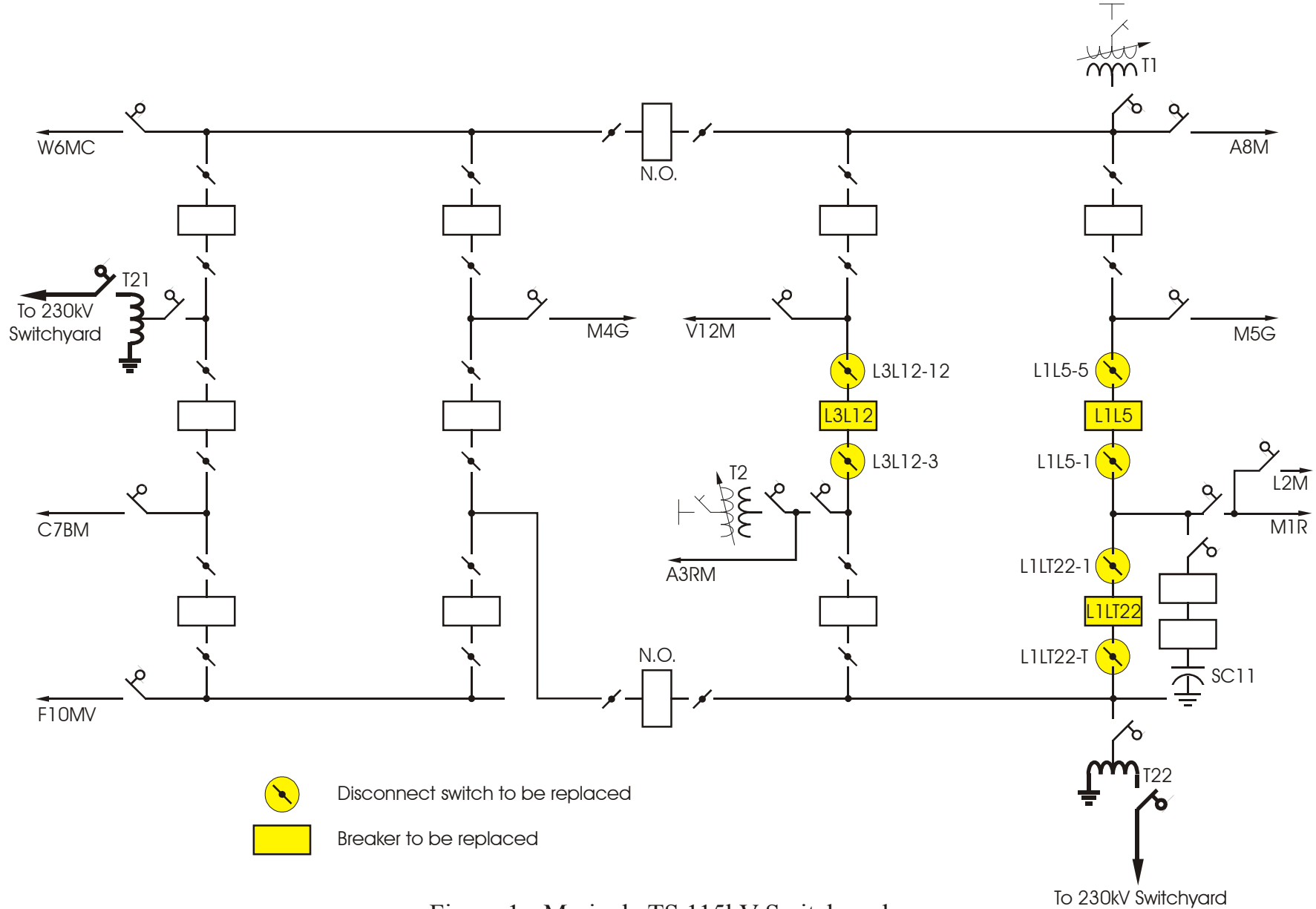

Figure 1 - Merivale TS 115kV Switchyard