



# **CONNECTION ASSESSMENT & APPROVAL PROCESS ASSESSMENT SUMMARY**

**Applicant: Cambridge and North Dumfries Hydro Inc.**

**Project: Preston TS – Install New 230kV Revenue  
Metering and Associated Facilities**

**CAA ID: 2002-EX048**

**Long Term Forecasts & Assessments Department**

**Date: August 08, 2002**

## 1.0 Background

Preston TS is a 230 – 27.6kV transformer station connected, via a double circuit tap, to the 230kV Middleport TS to Detweiler TS double circuit transmission line M20D/M21D. Preston TS is owned by Hydro One Networks Inc. and currently supplies only the Cambridge and North Dumfries Hydro Inc. (CNDHI) distribution system, a distribution company owned by the City of Cambridge and the Township of North Dumfries. The current revenue metering scheme at Preston TS is operating at 27.6kV and is owned by Hydro One Networks Inc.

The existing metering seal at Preston TS will expire in 2003. In accordance with the Market Rules, CNDHI will be the metered market participant of the wholesale revenue metering facilities at Preston TS and as such will be responsible to ensure the revenue metering installation is in compliance with the Market Rules when the existing metering seal expires.

## 2.0 Description of Proposal

CNDHI is proposing to replace the existing metering facilities with new metering installation that operates at 230kV. CNDHI has contracted Hydro One Networks Inc. and Hydro One Network Services Inc. to provide the installation, commissioning, and registration of the new revenue metering facilities. The project will include the followings:

- The installation of three CVTs and three metal oxide surge arrestors on each of the two line-taps from the 230kV Middleport to Detweiler transmission line M20D/M21D. The CVT and surge arrestor combinations will be installed at the points where the line taps are currently connected to the 230kV buses, as shown in Figure 1.
- The installation of three mid-span openers on each of the two line-taps from the 230kV transmission lines M20D and M21D. The mid-span openers will be installed at the line-tap entrances to the station just behind the station fence, as shown in Figure 1.
- The installation of three current transformers between the existing 230kV motorized disconnect switch 21T3-M21D and the transformer T3 and similarly between the 230kV disconnect switch 21T4-M20D and the transformer T4 (See Figure 1).
- The installation of structures, grounding system, cables, communication facilities, etc associated with the new revenue metering installation.

## 3.0 Assessment

The 230kV Middleport x Detweiler transmission circuits M20D and M21D are critical elements of the Bruce system. Protracted outage of either M20D or M21D affects the southern Ontario operating limits, as defined under System Control Orders SCO L-0122. In addition, an active energy market participant, Gerdau Courtice Steel Inc. has facilities connected to transmission circuit M21D and there are no switching facilities to transfer the load upon the loss of M21D. It is, therefore, prudent to ensure that the new revenue metering installation would not cause extended outages to either M20D or M21D.

## Assessment Summary

### Cambridge and North Dumfries Hydro Inc.

#### Preston TS – Install New 230kV Revenue Metering and Associated Facilities

---

With the proposed arrangement, the proposed mid-span openers in combination with the 230kV disconnect switch and the low voltage transformer breaker would permit the isolation of the new instrument transformers for any scheduled work on the devices without having to remove the 230kV circuit M20/21D out of service. But during the scheduled work period on either set of the instrument transformers, the associated power transformer would remain out of service as well. However, Preston TS is designed to withstand the loss of one transformer without losing supply to connected loads.

However, any fault on any of the new instrument transformers will remove either the 230kV circuit M20D together with the power transformer T4 or circuit M21D together with transformer T3 out of service.

If the new current transformers are involved, remotely operating the 230kV disconnect switches and the low voltage transformer breakers can quickly isolate them and restore M20D and/or M21D back to service. The power transformer T3 or T4 will have to remain out of service until the work on the current transformers is completed or until by-passes can be installed.

If the new CVTs are involved, having Hydro One Network Services Inc. personnel open the mid-span openers at the station can isolate the CVTs and restore M20D and/or M21D within a reasonable time. The outage to power transformers will be similar to the situation involving the current transformers.

It would have been a better arrangement to install the CVTs and the current transformers between the disconnect switches and the power transformers. With such an arrangement, when it is necessary to remove the instrument transformers out of service the motorized disconnect switches together with the low voltage transformer breakers could isolate them and restore M20D/M21D back to service quickly. However, at Preston TS, because of space limitation it is impossible to install both the revenue metering CVTs and the current transformers on the power transformer side of the disconnect switches.

With the exception of the time delay involved in isolating the new CVTs, the situation at Preston TS after the installation of the new revenue metering facilities is not any worse than the present with the existing metering facilities. Given the existence of the Bruce Special Protection Scheme, the time delay in restoring M20D and/or M21D is considered not to have any significant adverse impact on the operation of the IMO-controlled grid.

## 4.0 Notification of Approval

Based on the above assessment, it is recommended that a Notification of Approval for this proposal be granted to the applicant.

Assessment Summary

Cambridge and North Dumfries Hydro Inc.

Preston TS – Install New 230kV Revenue Metering and Associated Facilities

---

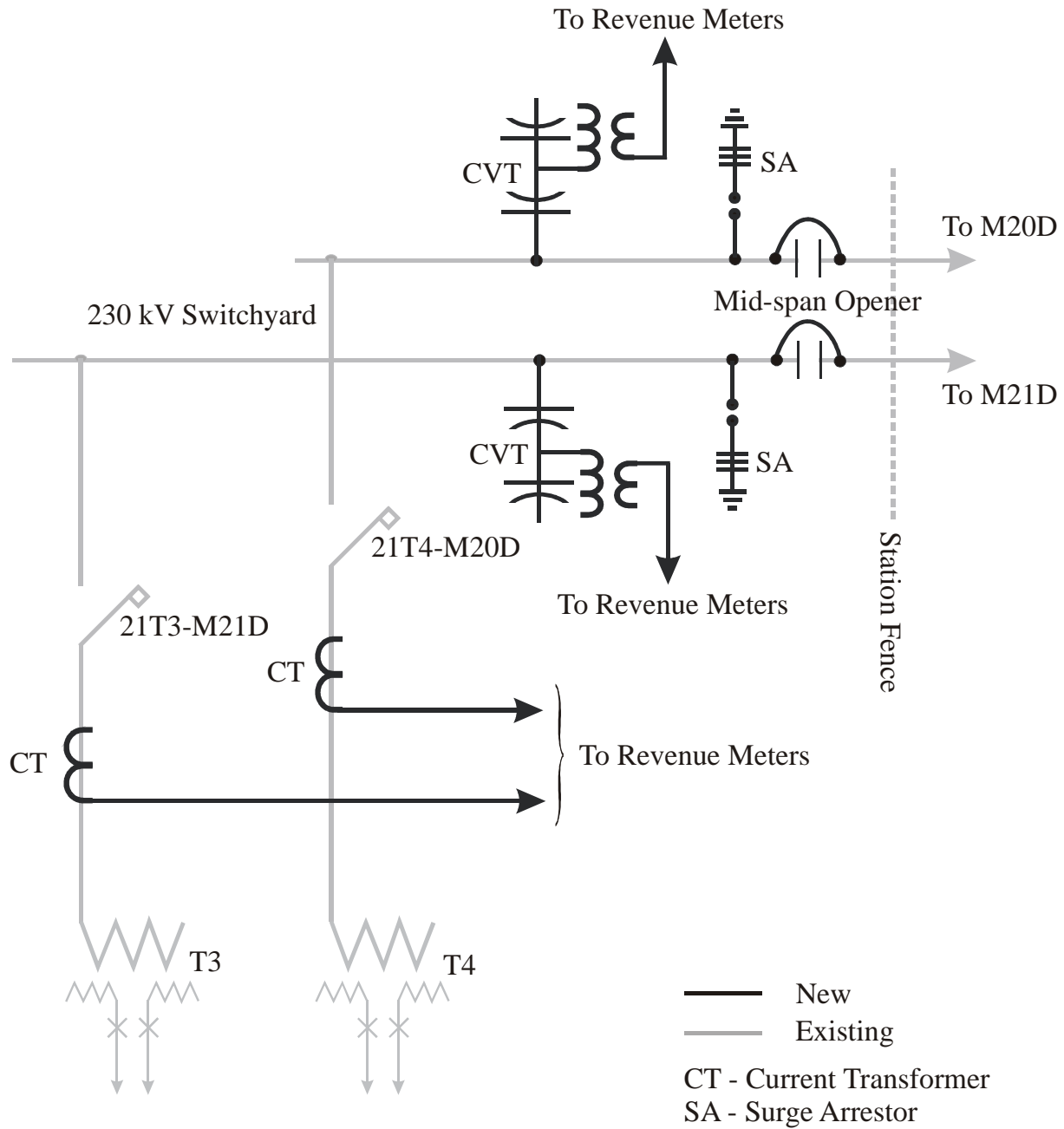

Figure 1 Preston TS - New Revenue Metering

August 2002