

January 14, 2010

Mr. Ibrahim El Nahas
Transmission Plans Manager - North
Transmission & Connection Planning Dept
Hydro One Networks Inc.
483 Bay Street
Toronto, Ontario
M5G 2P5



Dear Mr. El Nahas:

***SVC Connection Equipment at Porcupine TS and Kirkland Lake TS
Notification of Conditional Approval of Connection Proposal
CAA ID # 2009-EX459***

Thank you for the information regarding the installation of SVC connection equipment to connect the new SVCs at Porcupine TS and Kirkland Lake TS.

We have concluded that the proposed changes will not result in a material adverse impact on the reliability of the integrated power system.

The IESO is therefore pleased to grant **conditional approval** for the modification detailed in the attached assessment report. Any material changes to your proposal may require re-assessment by the IESO in accordance with Market Manual 2.10, and may nullify your conditional approval.

Final approval to connect the facility to the IESO-controlled grid will be granted upon successful completion of the IESO Market Entry process including, without limitation, satisfactory completion of the requirements set out in the System Impact Assessment report. During this process you will be expected to demonstrate that you have fulfilled the requirements and that the facility you have installed is materially unchanged from the proposal assessed by the IESO. Please refer to the '**External Guidelines for Connection to the IESO**' attachment in your approval email for key steps in the Market Entry process. In order to initiate this process, please contact Market Entry at market.entry@ieso.ca at least eight months prior to your energization date.

For further information, please contact the undersigned.

Yours truly,

Barbara Constantinescu
Manager – Market Facilitation
Telephone: (:905) 855-6406
Fax: (905) 855-6319
E-mail: barbara.constantinescu@ieso.ca
cc: IESO Records

Expedited System Impact Assessment Hydro One Networks

1.0 GENERAL DESCRIPTION & PROPOSED MODIFICATIONS

Hydro One is proposing to install Static VAr Compensators (SVCs) at Porcupine TS and Kirkland Lake TS in order to accommodate all of the existing generating facilities north of Sudbury plus the proposed expansion of the Mattagami River plants. The System Impact Assessment (SIA) report [2006-223](#) and its [addendum](#) address those SVCs.

This expedited SIA addresses the connection equipment needed at Porcupine TS and Kirkland Lake TS to install the SVCs.

The proposed connection arrangement for the Porcupine SVC is shown in Figure 1. The work includes the installation of two new 230kV breakers; together with the associated disconnect switches, to provide a connection point on the 230kV busbar at Porcupine TS for the new coupling transformer for the +300/-100MVar SVC. Modifications are also to be made to the protective relaying, surge protection, communications, controls and metering.

The proposed connection arrangement for the Kirkland Lake SVC is shown in Figure 2. The work includes the installation of a new 115kV breaker; together with the associated disconnect switches, to provide a connection point on the 115kV busbar at Kirkland Lake TS for the new coupling transformer for the +200/-100MVar SVC. Modifications are also to be made to the protective relaying, surge protection, communications, controls and metering.

Both SVCs are expected to be placed in-service during November 2010.

2.0 TECHNICAL SPECIFICATIONS

2.1 Porcupine TS

The technical specification for the new SVC coupling transformer at Porcupine TS is given below.

Porcupine TS Coupling Transformer	
Configuration	3 x single phase with 1 spare
Transformation (kV)	230/19.65 kV
Winding Configuration	Wye-delta
Thermal Rating	300 MVA
LTR	Not applicable
Positive Sequence Impedance (H-X)	14 % based on 300 MVA
Impedance to Ground	Solid ground
Under-load tap-changer	Not required
Off-load tap-changer	Not required
In service off-load tap position	Not applicable

Two new 230 kV breakers are to be installed at Porcupine TS to form a ring busbar. The existing 230kV circuit P91G is to be reterminated on to the position formed between the two new breakers, allowing the coupling transformer for the new SVC to be connected to the vacated position between the two existing breakers.

The technical specification for the new breakers is given below.

Breaker Specification Porcupine TS	
Maximum Continuous Operating Voltage	250 kV
Continuous Current Rating	2000 A
Short Circuit Symmetrical Current Rating	40 kA
Interrupting Medium	SF6
Rated Interrupting Time	3 cycles

Five new disconnect switches will installed, two for each breaker and one for the transformer for the SVC. The technical specification of the new disconnect switches is given below.

Disconnect Switch Specification Porcupine TS	
Note: the SVC disconnect switch must be motorized	
Configuration	3 phase
Maximum Continuous Operating Voltage	250 kV
Continuous Current Rating	2000 A
Short Circuit Symmetrical Current Rating	40 kA

2.2 Kirkland Lake TS

The technical specification for the new SVC coupling transformer at Kirkland Lake TS is given below.

Kirkland Lake TS Coupling Transformer	
Configuration	3 phase
Transformation (kV)	115/15 kV
Winding Configuration	Wye-delta
Thermal Rating	36.6 MVA
20-SEC Thermal Rating	200 MVA
Positive Sequence Impedance (H-X)	15 % based on 200 MVA
Impedance to Ground	Solid ground
Under-load tap-changer	Not required
Off-load tap-changer	Not required
In service off-load tap position	Not applicable

One new 115 kV breaker is to be installed adjacent to the existing D3D4 breaker in the ring busbar at Kirkland Lake TS. The coupling transformer for the new SVC is to be connected to the position created between the new breaker and the D3D4 breaker. The technical specification for the new breaker is given below.

Breaker Specification Kirkland Lake TS	
Maximum Continuous Operating Voltage	145 kV
Continuous Current Rating	2000 A
Short Circuit Symmetrical Current Rating	40 kA
Interrupting Medium	SF6
Rated Interrupting Time	3 cycles

Three new disconnect switches will be installed, two for the new breaker and one for the coupling transformer of the SVC. The technical specification for the new disconnect switches is given below.

Disconnect Switch Specification Porcupine TS	
Note: the SVC disconnect switch must be motorized	
Configuration	3 phase
Maximum Continuous Operating Voltage	145 kV
Continuous Current Rating	2000 A
Short Circuit Symmetrical Current Rating	40 kA

3.0 REQUIREMENTS

The proponent must notify the IESO as soon as it becomes aware of any changes to the assumptions made in the connection assessment. The IESO will determine whether these changes require a re-assessment.

Maximum Voltage

Appendix 4.1, reference 2 of the Market Rules states that under normal conditions the 115 and 230 kV systems in Ontario are maintained within the voltage ranges shown below. Thus, the IESO requires that high voltage equipment in Ontario must have maximum continuous voltage ratings as listed in the table below.

Fault interrupting devices must be able to interrupt fault current at the maximum continuous voltages.

Permissible Voltage Ranges in Ontario (Appendix 4.1, reference 2 of the Market Rules)		
	Voltage range	Maximum continuous voltage
115 kV system – northern Ontario	113 - 132 kV	132 kV
230 kV system	220 - 250 kV	250 kV

Fault Levels

The Transmission System Code (TSC), Appendix 2 establishes maximum fault levels for the transmission system. The maximum 3 phase symmetrical fault levels and the single line to ground (SLG) symmetrical fault levels are listed in the table below.

The TSC requires that new equipment be designed to sustain the fault levels in the area where the equipment is installed. If any future system enhancement results in an increased fault level higher than the equipment's

capability, the connection applicant is required to replace the equipment at their own expense with higher rated equipment capable of sustaining the increased fault level, up to the TSC's maximum fault levels as listed in the table below.

Maximum Permissible Fault levels in Ontario (Appendix 2 of the Transmission System Code)		
	maximum 3 phase symmetrical fault level	single line to ground (SLG) symmetrical fault level
115 kV system	50 kA	50 kA
230 kV system	63 KA	80 kA (usually limited to 63 kA)
500 kV system	80 kA	80 kA (usually limited to 63 kA)

Protections

Protection systems must be designed to satisfy all the requirements of the Transmission System Code as specified in Schedules E, F and G of Appendix 1 and any additional requirements identified by the transmitter. New protection systems must be coordinated with existing protection systems.

Facilities designated as essential to power system reliability must be protected by two redundant protection systems according to section 8.2.1a of the TSC. These redundant protections systems must satisfy all requirements of the TSC but in particular they may not use common components, common battery banks or common secondary CT or PT windings.

As currently assessed, these facilities are not designated as essential to power system reliability and therefore the above protection requirements do not apply. In the future, as the electrical system evolves, these facilities may be designated as such and at that time the above requirements will apply.

Protective relaying must be set to ensure that transmission equipment remains in-service for voltages between 94% of the minimum continuous and 105% of the maximum continuous values in the Market Rules, Appendix 4.1.

The Applicant is required to have adequate provision in the design of protections and controls at the facility to allow for future installation of Special Protection Scheme (SPS) equipment.

The transmitter shall identify any protection relay modifications (e.g. equipment and settings) required to incorporate the new facility into the integrated power system. To allow sufficient time to assess the impact on power system reliability, the transmitter must submit any proposed protection relay modifications to the IESO as soon as the protection assessment for the new facility is finished or at least six (6) months before any actual modifications are to be implemented on the existing protection systems.

The IESO will evaluate the impact on system reliability due to any protection relay modifications and any modifications to functionality, timing or reach. The IESO will not assess aspects of protection systems which are solely the accountability of the transmitter (e.g. coordination of protection relays). Any modifications made to protection relays by the transmitter after this SIA is finalized must be submitted to the IESO as soon as possible or at least six (6) months before any modifications are to be implemented on the existing protection systems. If those modifications result in adverse impacts, the connection applicant and the transmitter must develop mitigation solutions.

Send documentation for protection modifications triggered by new or modified primary equipment (i.e. new or replacement relays) to connection.assessments@ieso.ca.

For protection modifications that are not associated with new or modified equipment (i.e. protection setting modifications) please send documentation to protection.settings@ieso.ca.

IESO Monitoring Requirements - Transmitters

In accordance with the telemetry requirements for transmitters (see Appendices 4.16, 4.20 and 4.21 of the Market Rules) the connection applicant must install equipment at this project with specific performance standards to provide telemetry data to the IESO. The data is to consist of certain equipment status and operating quantities which will be identified during the IESO Market Entry Process.

Facility Registration/Market Entry Requirements

The connection applicant must complete the IESO Facility Registration/Market Entry process in a timely manner before IESO final approval for connection is granted. Models and data, including any controls that would be operational, must be provided to the IESO. This information should be submitted at least seven months before energization to the IESO-controlled grid, to allow the IESO to incorporate this project into IESO work systems and to perform any additional reliability studies.

As part of the IESO Facility Registration/Market Entry process, the connection applicant must provide evidence to the IESO confirming that the equipment installed meets the Market Rules requirements and matches or exceeds the performance predicted in this assessment. This evidence shall be either type tests done in a controlled environment or commissioning tests done on-site. In either case, the testing must be done not only in accordance with widely recognized standards, but also to the satisfaction of the IESO. Until this evidence is provided and found acceptable to the IESO, the Facility Registration/Market Entry process will not be considered complete and the connection applicant must accept any restrictions the IESO may impose upon this project's participation in the IESO administered market or connection to the IESO-controlled grid.

The evidence must be supplied to the IESO within 30 days after completion of commissioning tests. Failure to provide evidence may result in disconnection from the IESO-controlled grid.

If the submitted models and data differ materially from the ones used in this assessment, then further analysis of the project will need to be done by the IESO.

4.0 ASSESSMENT & CONCLUSIONS**4.1 New Connection Equipment at Porcupine TS and Kirkland Lake TS**

The information provided by Hydro One shows that the new connection equipment at Porcupine TS and Kirkland Lake TS is not expected to have a material adverse impact on the IESO-controlled grid.

4.2 Conclusions

This expedited System Impact Assessment concludes that the installation of the new coupling transformers, breakers and disconnect switches are not expected to have a material adverse impact on the IESO-controlled grid.

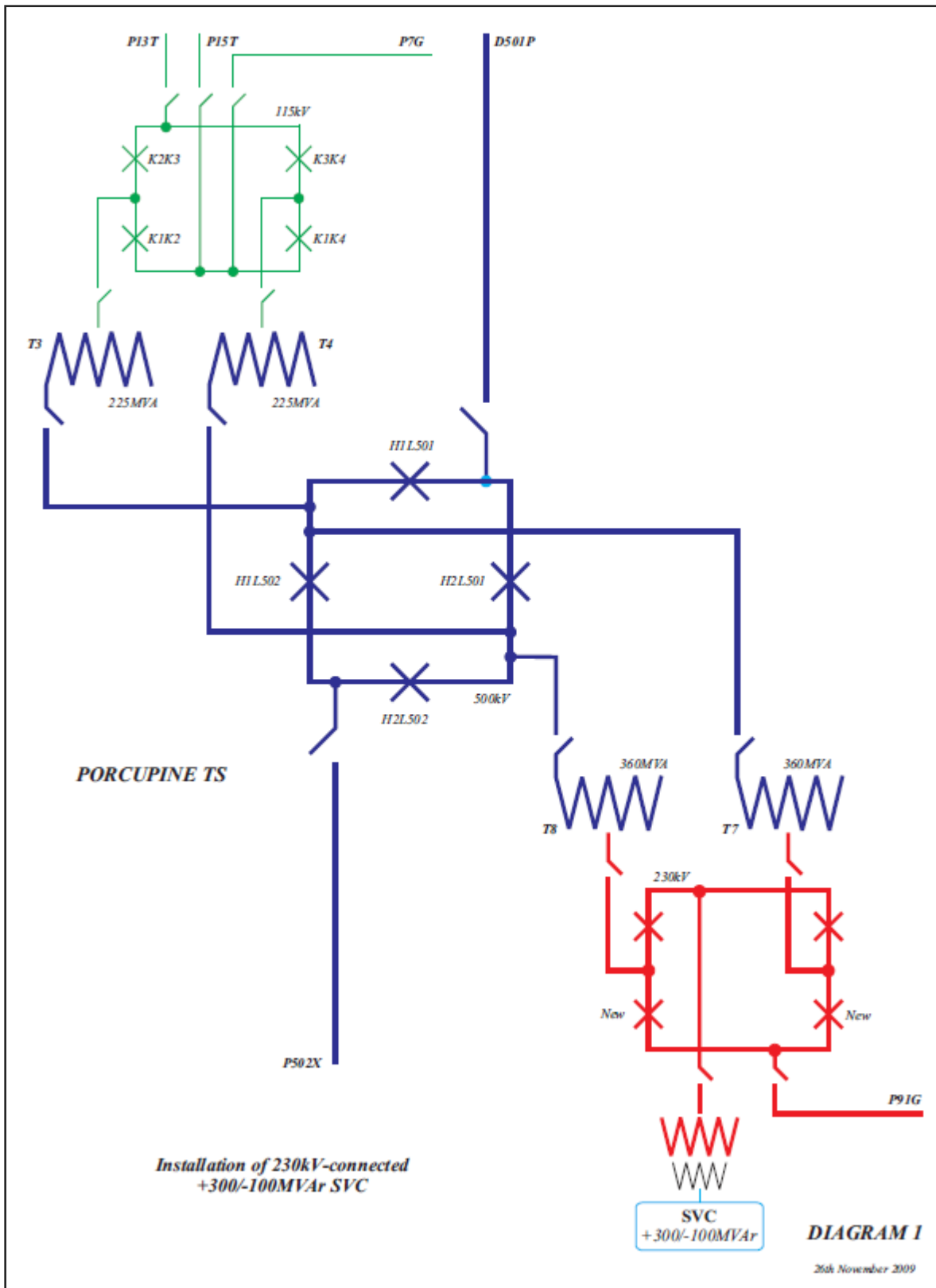

Figure 1 – Single Line Diagram for New SVC Connection at Porcupine TS

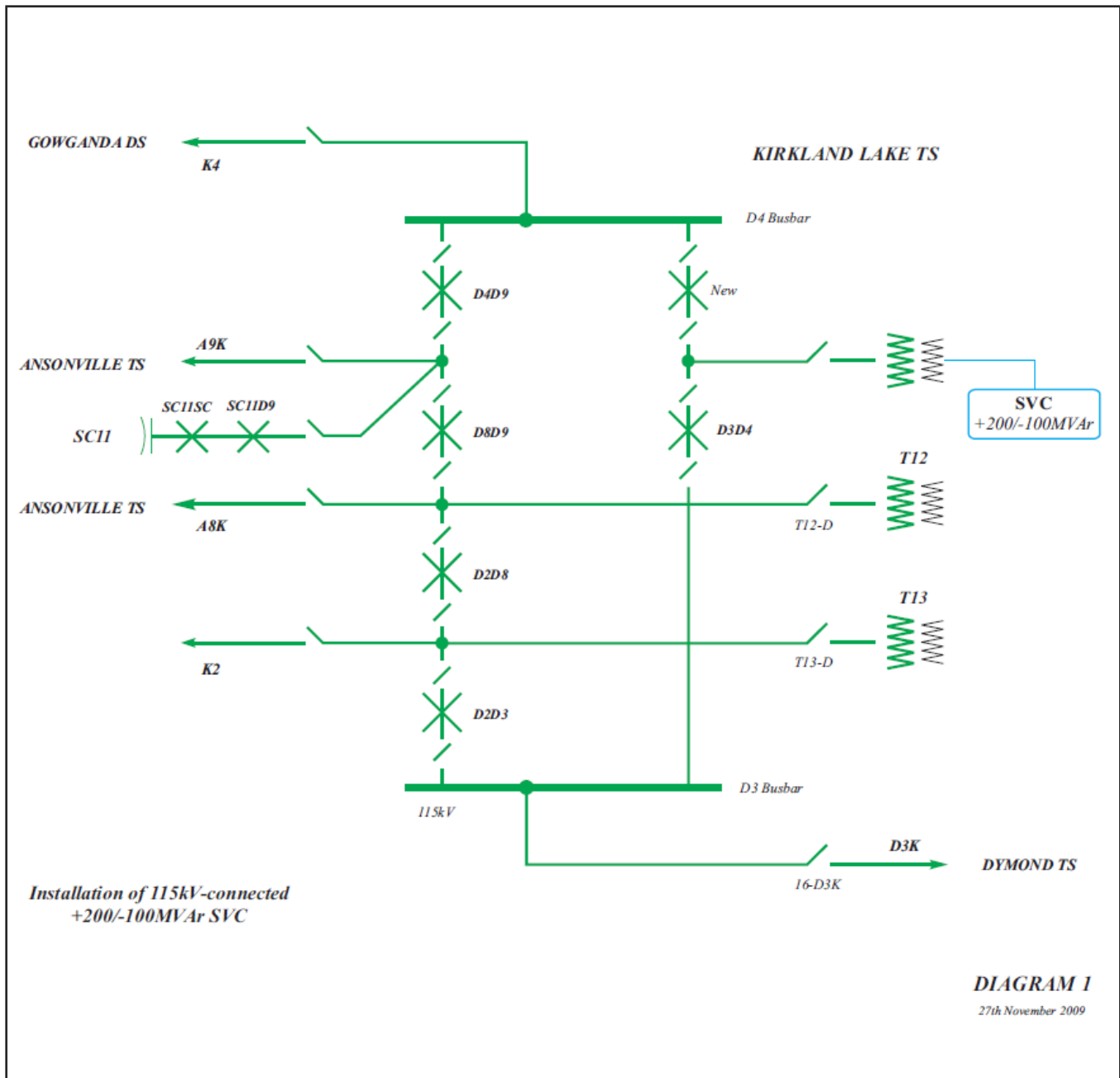

Figure 2 – Single Line Diagram for New SVC Connection at Kirkland Lake TS