



Power to Ontario.
On Demand.

REPORT

System Impact Assessment Report

**Northland Power Solar Martin's
Meadows, Abitibi and Empire**

**CONNECTION ASSESSMENT &
APPROVAL PROCESS**

Final Report

CAA ID 2010-403, 2010-406, 2010-409

*Applicant: Northland Power Solar Martin's Meadows L.P.,
Northland Power Solar Abitibi L.P.
Northland Power Solar Empire L.P*

Market Facilitation Department

January 6, 2011

System Impact Assessment Report

Document ID	IESO_REP_0666
Document Name	System Impact Assessment Report
Issue	1.0
Reason for Issue	Final Report
Effective Date	January 6, 2011

System Impact Assessment Report

Northland Power Solar Martin's Meadows, Abitibi and Empire

Acknowledgement

The IESO wishes to acknowledge the assistance of Hydro One in completing this assessment.

Disclaimers

IESO

This report has been prepared solely for the purpose of assessing whether the connection applicant's proposed connection with the IESO-controlled grid would have an adverse impact on the reliability of the integrated power system and whether the IESO should issue a notice of approval or disapproval of the proposed connection under Chapter 4, section 6 of the Market Rules.

Approval of the proposed connection is based on information provided to the IESO by the connection applicant and the transmitter(s) at the time the assessment was carried out. The IESO assumes no responsibility for the accuracy or completeness of such information, including the results of studies carried out by the transmitter(s) at the request of the IESO. Furthermore, the connection approval is subject to further consideration due to changes to this information, or to additional information that may become available after the approval has been granted. Approval of the proposed connection means that there are no significant reliability issues or concerns that would prevent connection of the proposed facility to the IESO-controlled grid. However, connection approval does not ensure that a project will meet all connection requirements. In addition, further issues or concerns may be identified by the transmitter(s) during the detailed design phase that may require changes to equipment characteristics and/or configuration to ensure compliance with physical or equipment limitations, or with the Transmission System Code, before connection can be made.

This report has not been prepared for any other purpose and should not be used or relied upon by any person for another purpose. This report has been prepared solely for use by the connection applicant and the IESO in accordance with Chapter 4, section 6 of the Market Rules. The IESO assumes no responsibility to any third party for any use, which it makes of this report. Any liability which the IESO may have to the connection applicant in respect of this report is governed by Chapter 1, section 13 of the Market Rules. In the event that the IESO provides a draft of this report to the connection applicant, you must be aware that the IESO may revise drafts of this report at any time in its sole discretion without notice to you. Although the IESO will use its best efforts to advise you of any such changes, it is the responsibility of the connection applicant to ensure that it is using the most recent version of this report.

HYDRO ONE

Special Notes and Limitations of Study Results

The results reported in this study are based on the information available to Hydro One, at the time of the study, suitable for a preliminary assessment of a new generation or load connection proposal.

System Impact Assessment Report

The short circuit and thermal loading levels have been computed based on the information available at the time of the study. These levels may be higher or lower if the connection information changes as a result of, but not limited to, subsequent design modifications or when more accurate test measurement data is available.

This study does not assess the short circuit or thermal loading impact of the proposed connection on facilities owned by other load and generation (including OPG) customers.

In this study, short circuit adequacy is assessed only for Hydro One breakers and does not include other Hydro One facilities. The short circuit results are only for the purpose of assessing the capabilities of existing Hydro One breakers and identifying upgrades required to incorporate the proposed connection. These results should not be used in the design and engineering of new facilities for the proposed connection. The necessary data will be provided by Hydro One and discussed with the connection proponent upon request.

The ampacity ratings of Hydro One facilities are established based on assumptions used in Hydro One for power system planning studies. The actual ampacity ratings during operations may be determined in real-time and are based on actual system conditions, including ambient temperature, wind speed and facility loading, and may be higher or lower than those stated in this study.

The additional facilities or upgrades which are required to incorporate the proposed connection have been identified to the extent permitted by a preliminary assessment under the current IESO Connection Assessment and Approval process. Additional facility studies may be necessary to confirm constructability and the time required for construction. Further studies at more advanced stages of the project development may identify additional facilities that need to be provided or that require upgrading.

Table of Contents

Table of Contents	v
Description	6
Findings	6
IESO’s Requirements for Connection	7
Other Requirements:	10
Recommendations	11
Notification of Conditional Approval	11
1. Project Description	12
2. General Requirements	13
3. Review of Connection Proposal	17
3.1 Proposed Connection Arrangement	17
3.2 Existing System	18
3.2.1 Existing & New Generation	18
3.2.2 Existing Load Facilities	19
3.2.3 Existing Transmission	21
4. Data Verification	25
4.1 Tap Line	25
4.2 Generator	25
4.3 Transformer	25
4.4 Circuit Breakers and Switches	25
4.5 Collector System	26
5. Fault Level Assessment	27
6. System Impact Studies	31
6.1 Assumptions and Background	31
6.2 Protection Impact Assessment	33
6.3 Reactive Power Compensation	33
6.3.1 Dynamic Reactive Power Compensation	34
6.3.2 Static Reactive Power Compensation	35
6.4 Solar Farm Management System	36
6.5 Thermal Analysis	37
6.6 Voltage Analysis	42
6.7 Transient Analysis	44
6.8 Relay Margin	47
6.9 Low-Voltage Ride Through Capability	47
6.10 Special Protection System (SPS)	49
Appendix A: Diagrams for Transient Simulation Results	50
Appendix B: Protection Impact Assessment	59

Executive Summary

Description

Northland Power is developing a new 30 MW solar power generation facility in Cochrane, Ontario. The project was awarded 3 x 10 MW procurement contracts under the Ontario government Feed-In-Tariff (FIT) program, and is expected to start commercial operation in November 2012.

This assessment examined injecting 30 MW of solar power generation into the provincial grid via the 115 kV circuit A5H and its effects on the reliability of the IESO-controlled grid.

The following conclusions and recommendations were made:

Findings

The analysis concluded that:

- (1) The proposed solar development does not have a material adverse impact on the reliability of the IESO-controlled grid.
- (2) The increase in fault levels due to the proposed solar development will not exceed the interrupting capabilities of the existing breakers on the IESO-controlled grid or the proposed breakers at the new facility.
- (3) Protection modifications to accommodate the proposed solar development have no adverse impact on the reliability of the IESO-controlled grid.
- (4) With existing Hanmer TS reactors R1 and R2 in-service and not capable of being switched out of service on-load and with all new FIT and expanded Lower Mattagami generation in-service, congestion will increase on the P502X circuit and the Flow South system interface.
- (5) Existing congestion on the 115 kV circuit H6T was identified with all local area generation in-service and operating near their maximum installed capacity. The proposed project increases pre-contingency power flows and thus increases congestion.
- (6) Congestion of the 115 kV A5H circuit was identified with the proposed project and existing Tunis and Cochrane generation facilities injecting into circuit A5H. To alleviate these congestion issues, operating restrictions will need to be implemented to prevent the simultaneous connection of the three facilities to the A5H circuit when they are operating near their maximum installed capacity.
- (7) Existing post-contingency thermal overloads of 115 kV circuits H6T and H7T were identified for the loss of the Ansonville T2 autotransformer and the inadvertent breaker operation (IBO) of the 115 kV H1L91 circuit breaker at Ansonville. The proposed project increases post-contingency power flows and thus increases these overloading issues.
- (8) Post-contingency voltage stability and overvoltage issues exist with the loss of the 500 kV circuit P502X without the rejection of new and existing capacitor banks at Hanmer TS and Porcupine TS.

No other voltage concerns were identified with the incorporation of the proposed project.

- (9) Relay margin violations exist at the Kirkland Lake terminal of the D3K circuit for a 3 phase fault on the 500 kV circuit P502X at Hanmer TS.
- (10) Existing transient stability issues of the embedded Lower Sturgeon GS generators were identified for L-L-G faults on the 115 kV P13T circuit. The proposed project contributes to this existing issue. Due to the small MW rating of the Lower Sturgeon embedded generators and the fact that their instability is contained within their distribution system, this issue does not pose any reliability concerns to the IESO.

All other transient contingencies show stable and well damped oscillations with the incorporation of the proposed project.
- (11) The reactive power capability of the PV inverters along with the impedance between the inverters and the IESO controlled grid results in an approximate 5 Mvar dynamic reactive deficiency and 1 Mvar static reactive power deficiency at the connection point.
- (12) Based on the information provided by the applicant, the fault ride through capability of the PV inverters is adequate.
- (13) The proposed solar facility must connect to and participate in the Northeast 115 kV L/R & G/R Special Protection System. The Northeast 115 kV L/R & G/R scheme is expected to maintain its Type III Special Protection Scheme classification after the incorporation of the proposed project.

IESO's Requirements for Connection

Transmitter Requirements

The following requirements are applicable for Hydro One for the incorporation of Northland Power Martin's Meadows, Abitibi and Empire.

- (1) The transmitter changes the relay settings of A5H terminal stations to account for the effect of the solar farm. Modifications to protection relays after this SIA is finalized must be submitted to IESO as soon as possible or at least six (6) months before any modifications are to be implemented. If those modifications result in adverse impacts, the connection applicant and the transmitter must develop mitigating solutions.
- (2) The transmitter modifies the existing 115 kV Northeast L/R & G/R scheme to allow for the selection of the Martin's Meadows, Abitibi and Empire solar facility upon the detection of the P502X, P91G, A4H, H6T, H7T, H6T & H7T, H1L91 IBO and Ansonville T2 contingencies. G/R can be initiated by tripping the total 30 MW facility via the 115 kV breaker located at the project's connection point to the IESO controlled grid.

Applicant Requirements

Specific Requirements: The following specific requirements are applicable to the applicant for the incorporation of Northland Power Martin's Meadows, Abitibi and Empire. Specific requirements pertain to the level of reactive compensation needed, operation restrictions, Special Protection System, upgrading of equipment and any project specific items not covered in the general requirements:

- (1) The solar farm (SF) is required to have the capability to inject or withdraw reactive power continuously (i.e. dynamically) at a connection point up to 33% of its rated active power at all levels of active power output. Based on the equivalent parameters for the SF provided by the connection applicant, the IESO's simulations resulted in the following:
 - With the existing 0.95 leading to 0.95 lagging reactive power capability of the SMA SC500HE-US inverters, a dynamic reactive power device (SVC) with a capability of **+6 Mvar** has to be installed at the facility to compensate for the reactive power deficiency of the facility. The location of this device can be at the facility 115 kV overhead bus or behind one of the LV collector buses.
 - Should future enhancements of the SC500HE-US inverter provide an increased dynamic reactive power range of 0.9 leading and lagging (as indicated by the inverter manufacturer), the applicant must communicate the inverter reactive power capability changes to the IESO to allow for reassessment of reactive power requirements.

The connection applicant has the obligation to ensure that the SF has the capability to meet the Market Rules requirement at the connection point and be able to confirm this capability during the commission tests.

- (2) The total 30 MW Martin's Meadows, Empire and Abitibi facility is required to participate in the existing Northeast 115 kV L/R & G/R SPS for various 115, 230 and 500 kV contingencies in the Northeast power system.
- (3) The connection applicant is required to provide a copy of the functionalities of the Solar Farm Management System (SFMS) to the IESO. The SFMS must coordinate the voltage control process.
- (4) The connection applicant is required to ensure that the response time of inverter var output to changes in AVR reference voltages must be minimal and similar to conventional generator technologies. Simulations using minimum acceptable default parameters of a hydroelectric facility in place of the PV inverters yielded a var response time of approximately 0.55 sec. The connection applicant is required to have similar or better var response time performance.

General Requirements: The proposed connection must comply with all the applicable requirements from the Transmission System Code (TSC), IESO Market Rules and standards and criteria. The most relevant requirements are summarized below and presented in more detail in Section 2 of this report.

- (1) The new generator must satisfy the Generator Facility Requirements in Appendix 4.2 of the Market Rules.
- (2) All 115 kV equipment must have a maximum continuous voltage rating and the ability to interrupt fault current at a voltage of at least 132 kV.
- (3) Any revenue metering equipment that is installed must comply with Chapter 6 of the Market Rules.
- (4) Equipment must sustain increased fault levels due to future system enhancements. Should future system enhancements result in fault levels exceeding equipment capability, the applicant is required to replace equipment at its own expense with higher rated equipment, up to 50 kA as per the Transmission System Code for the 115 kV system.

- (5) The 115 kV breakers must meet the required interrupting time of less than or equal to 5 cycles as per the Transmission System Code.
- (6) The connection equipment must be designed such that adverse effects due to failure are mitigated on the IESO-controlled grid.
- (7) The connection equipment must be designed for full operability in all reasonably foreseeable ambient temperature conditions.
- (8) The facility must satisfy telemetry requirements as per Appendices 4.15 and 4.19 of the Market Rules. The determination of telemetry quantities and telemetry testing will be conducted during the IESO Facility Registration/Market entry process.
- (9) Protection systems must satisfy requirements of the Transmission system code and specific requirements from the transmitter. New protection systems must be coordinated with existing protection systems.
- (10) Protective relaying must be configured to ensure transmission equipment remains in service for voltages between 94% of minimum continuous and 105% of maximum continuous values as per Market Rules, Appendix 4.1.
- (11) Protection systems within the generation facility must only trip appropriate equipment required to isolate the fault.
- (12) The autoreclosure of the new 115 kV breaker(s) at the connection point must be blocked. Upon its opening for a contingency, it must be closed only after the IESO approval is granted. The IESO will require reduction of power generation prior to the closure of the breaker(s) followed by gradual increase of power to avoid a power surge.
- (13) The generator must operate in voltage control mode. The generation facility shall regulate automatically voltage at a point whose impedance (based on rated apparent power and rated voltage) is not more than 13% from the highest voltage terminal based within $\pm 0.5\%$ of any set point within $\pm 5\%$ of rated voltage. If the AVR target voltage is a function of reactive output, the slope $\Delta V / \Delta Q_{\max}$ shall be adjustable to 0.5%.
- (14) A disturbance monitoring device must be installed. The applicant is required to provide disturbance data to the IESO upon request.
- (15) Mathematical models and data, including any controls that would be operational, must be provided to the IESO through the IESO Facility Registration/Market Entry process at least seven months before energization from the IESO-controlled grid. That includes both PSS/E and DSA software compatible mathematical models representing the new equipment for further IESO, NPCC and NERC analytical studies. The *connection applicant* may need to contact the software manufacturers directly, in order to have the models included in their packages. If the data or assumptions supplied for the registration of the facilities materially differ from those that were used for the assessment, then some of the analysis might need to be repeated.
- (16) The registration of the new facilities will need to be completed through the IESO's Market Entry process before IESO final approval for connection is granted and any part of the facility can be placed in-service.

- (17) As part of the IESO Facility Registration/Market Entry process, the connection applicant must provide evidence to the IESO confirming that the equipment installed meets the Market Rules requirements and matches or exceeds the performance predicted in this assessment. Until this evidence is provided and found acceptable to the IESO, the Facility Registration/Market Entry process will not be considered complete and the connection applicant must accept any restrictions the IESO may impose upon this project's participation in the IESO administered market or connection to the IESO-controlled grid. Failure to provide evidence may result in disconnection from the IESO-controlled grid.
- (18) During the commissioning period, a set of IESO specified tests must be performed. The commissioning report must be submitted to the IESO within 30 days of the conclusion of commissioning. Field test results should be verifiable using the PSS/E models used for this SIA.
- (19) The proposed facility must be compliant with applicable reliability standards set by the North American Electric Reliability Corporation (NERC) and the North East Power Coordinating Council (NPCC) prior to energization to the IESO controlled grid.
- (20) The applicant may meet the restoration participant criteria as per the NERC standard EOP-005. Further details can be found in section 3 of Market Manual 7.8 (Ontario Power System Restoration Plan).

Please be advised that rules regarding the connection of renewable generation facilities are currently being reviewed through the SE-91 stakeholder initiative and new connection requirements in addition to the ones outlined in this report might be placed. More details can be found through the following link:

http://www.ieso.ca/imoweb/consult/consult_se91.asp

Other Requirements:

The following requirements are applicable to Hydro One to address as soon as practical. Connection to the grid of the NP Solar Martin's Meadows, Abitibi and Empire facility is not dependent on the implementation of the following requirements. While physical implementation of the following requirements are the responsibility of Hydro One, cost responsibility of the following network upgrades will be determined by the rules set forth in the TSC (Transmission System Code).

- (1) The transmitter upgrades 115 kV circuit H6T from Laforest Road JCT to Timmins TS and 115 kV circuit H7T from Warkus JCT to Timmins TS to help alleviate thermal overloads.
- (2) The transmitter modifies the existing 115 kV Northeast L/R & G/R scheme to allow G/R of various 115 kV generation facilities around the Hunta system for the selection of the Ansonville T2 and H1L91 IBO contingencies to help alleviate post-contingency thermal overload of the H6T and H7T circuits. Units selectable for G/R should include Tunis, Cochrane, Long Sault Rapids and the entire NP Solar Martin's Meadows, Abitibi and Empire facility.
- (3) The transmitter implements an automatic switching scheme for new and existing capacitors located at Hanmer TS, Porcupine TS and Pinard TS to help alleviate post-contingency voltage stability and overvoltage issues in the Northeast system. This switching can be implemented using a voltage based switching scheme on the condition that voltage thresholds are suitably chosen and time delays are minimal. Should Hydro One be unable to meet these conditions, the automatic switching of these capacitors will need to be added as responses to various contingencies to the existing Moose River G/R and/or Northeast 115 kV L/R & G/R schemes. This requirement is consistent with conclusions

and requirements made in the Lower Mattagami Generation Expansion system impact assessment (CAA ID 2006-239).

- (4) The transmitter continue work in resolving existing relay margin violations at the Kirkland Lake terminal of the D3K circuit for faults to the 500 kV circuit P502X. Possible solutions include revising 'B' protection settings to reduce the Zone 2 quad characteristic. This requirement is consistent with conclusions and requirements made in various system impact studies completed for the incorporation of Nobel SS (CAA ID 2004-160), Lower Mattagami Expansion (CAA ID 2006-239), Porcupine and Kirkland Lake SVC (CAA ID 2006-223).

Recommendations

- (1) Hydro One improve teleprotections for the 115 kV P13T and P15T circuits, to help improve remote end fault clearing times for faults associated with these circuits.
- (2) Hydro One explore the feasibility of making reactors R1 and R2 at Hanmer TS capable of being switched in and out of service on-load. This will increase power transfer capability through the P502X circuit and the Flow South interface.

Notification of Conditional Approval

From the information provided, our review concludes that the proposed connection of Northland Power Martin's Meadow, Empire and Abitibi, subject to the requirements specified in this report will not result in a material adverse effect on the reliability of the IESO-controlled grid.

It is recommended that a Notification of Conditional Approval for Connection be issued for Northland Power Martin's Meadows, Abitibi and Empire subject to the implementation of the requirements listed in this report.

1. Project Description

Northland Power is proposing to develop a 30 MW solar farm located in Cochrane, Ontario. The project will consist of 3 x 10 MW sites known as Northland Power Solar Martin's Meadows, Abitibi and Empire each of which have been awarded Power Purchase Agreements under the Feed-in-Tariff (FIT) program with the Ontario Power Authority. It is expected that commercial operation will start in November 2012.

The three projects are part of one total facility connecting to Hydro One's existing 115 kV A5H circuit, approximately 14.5 km from Hunta SS. The three individual sites will be connected to A5H via one common 115 kV bus and a newly built 10.5 km, 115 kV tap circuit. Three separate substations will connect each of the three sites to the common 115 kV bus. Each substation will consist of one 27.6/115 kV transformer, one 115 kV circuit breaker and a motorized disconnect switch. The 27.6 kV side of the transformer will connect to an underground cable collector system.

Each of the sites will consist of a total of 20 SMA SC500 PV inverters with a rated power output of 0.5 MW each. Each inverter will be connected to one of two low voltage sides of a three winding step up transformer rated at 1 MVA each.

SMA SC500HE-US (0.5 MW each)				
Site	Martin's Meadows	Abitibi	Empire	Total
Number of PV inverters	20	20	20	60
Maximum MW	10	10	10	30

– End of Section –

2. General Requirements

Generators

Each generator must satisfy the Generator Facility requirements in Appendix 4.2 of Market Rules.

The Market Rules (appendix 4.2) require that the generation facility directly connecting to the IESO-controlled grid must have the capability to operate continuously between 59.4Hz and 60.6Hz and for a limited period of time in the region above straight lines on a log-linear scale defined by the points (0.0s, 57.0Hz), (3.3s, 57.0Hz), and (300s, 59.0Hz).

The generators shall respond to frequency increase by reducing the active power with an average droop based on maximum active power adjustable between 3% and 7% and set at 4%. Regulation deadband shall not be wider than $\pm 0.06\%$. A sustained 10% change of rated active power after 10 s in response to a constant rate of change of frequency of 0.1%/s during interconnected operation shall be achievable.

The generators must be able to ride through routine switching events and design criteria contingencies assuming standard fault detection, auxiliary relaying, communication, and rated breaker interrupting times unless disconnected by configuration.

The generation facility directly connecting to the IESO-controlled grid must have the minimum capability to supply continuously all levels of active power output for 5% deviations in terminal voltage. Rated active power is the smaller output at either rated ambient conditions (e.g. temperature, head, wind speed, solar radiation) or 90% of rated apparent power. To satisfy steady-state reactive power requirements, active power reductions to rated active power are permitted.

The generation facility must have the capability to inject or withdraw reactive power continuously (i.e. dynamically) at a *connection point* up to 33% of its rated active power at all levels of active power output except where a lesser continually available capability is permitted by the IESO. If necessary, shunt capacitors must be installed to offset the reactive power losses within the facility in excess of the maximum allowable losses. If generators do not have dynamic reactive power capabilities as described above, dynamic reactive compensation devices must be installed to make up the deficient reactive power.

The generation facility shall automatically regulate voltage at a point whose impedance (based on rated apparent power and rated voltage) is not more than 13% from the highest voltage terminal based within $\pm 0.5\%$ of any set point within $\pm 5\%$ of rated voltage. If the AVR target voltage is a function of reactive output, the slope $\Delta V / \Delta Q_{\max}$ shall be adjustable to 0.5%. The equivalent time constants shall not be longer than 20 ms for voltage sensing and 10 ms for the forward path to the regulator output.

Connection Equipment (Breakers, Disconnects, Transformers, Buses)

- Appendix 4.1, reference 2 of the Market Rules states that under normal conditions voltages in Northern Ontario are maintained within the range of 113 kV to 132 kV. Thus, the IESO requires that 115 kV equipment in Northern Ontario must have a maximum continuous voltage rating of at least 132 kV.

Fault interrupting devices must be able to interrupt fault current at the maximum continuous voltage of 132 kV.

If revenue metering equipment is being installed as part of this project, please be aware that revenue metering installations must comply with Chapter 6 of the IESO Market Rules for the Ontario electricity market. For more details the applicant is encouraged to seek advice from their Metering Service Provider (MSP) or from the IESO metering group.

2. The Transmission System Code (TSC), Appendix 2 establishes maximum fault levels for the transmission system. For the 115 kV system, the maximum 3 phase and single line to ground (SLG) symmetrical fault levels are 50 kA.

The TSC requires that new equipment be designed to sustain the fault levels in the area where the equipment is installed. If any future system enhancement results in an increased fault level higher than the equipment's capability, the connection applicant is required to replace the equipment at their own expense with higher rated equipment capable of sustaining the increased fault level, up to the TSC's maximum fault level of 50 kA for the 115 kV system.

3. The Transmission System Code (TSC), Appendix 2 states that the maximum rated interrupting time for 115 kV breakers must be ≤ 5 cycles. The connection applicant shall ensure that the new breakers meet the required interrupting time as specified in the TSC.

4. The connection equipment must be designed so that the adverse effects of failure on the IESO-controlled grid are mitigated. This includes ensuring that all circuit breakers fail in the open position.

5. The connection equipment must be designed so that it will be fully operational in all reasonably foreseeable ambient temperature conditions.

IESO Monitoring and Telemetry Data

In accordance with the telemetry requirements for a generation facility (see Appendices 4.15 and 4.19 of the Market Rules) the connection applicant must install equipment at this project with specific performance standards to provide telemetry data to the IESO. The data is to consist of certain equipment status and operating quantities which will be identified during the IESO Market Entry Process.

As part of the IESO Facility Registration/Market Entry process, the connection applicant must also complete end to end testing of all necessary telemetry points with the IESO to ensure that standards are met and that sign conventions are understood. All found anomalies must be corrected before IESO final approval to connect any phase of the project is granted.

Protection Systems

1. Protection systems must be designed to satisfy all the requirements of the Transmission System Code as specified in Schedules E, F and G of Appendix 1 (version B) and any additional requirements identified by the transmitter. New protection systems must be coordinated with existing protection systems.

2. Protective relaying must be set to ensure that transmission equipment remains in-service for voltages between 94% of the minimum continuous and 105% of the maximum continuous values in the Market Rules, Appendix 4.1.

3. Any modifications made to protection relays by the transmitter after this SIA is finalized must be submitted to the IESO as soon as possible or at least six (6) months before any modifications are to be implemented on the existing protection systems. If those modifications result in adverse impacts, the connection applicant and the transmitter must develop mitigation solutions.

Send documentation for protection modifications triggered by new or modified primary equipment (i.e. new or replacement relays) to connection.assessments@ieso.ca.

4. Protection systems within the generation facility must only trip the appropriate equipment required to isolate the fault. After the facility begins commercial operation, if an improper trip of the 115 kV circuit A5H occurs due to events within the facility, the facility may be required to be disconnected from the IESO-controlled grid until the problem is resolved.

5. The autoreclosure of the new 115 kV breakers at the connection point must be blocked. Upon its opening for a contingency, it must be closed only after the IESO approval is granted. The IESO will require reduction of power generation prior to the closure of the breaker followed by gradual increase of power to avoid a power surge.

Miscellaneous

1. The Connection Applicant is required to install at the facility a disturbance recording device with clock synchronization that meets the technical specifications provided by Hydro One. The device will be used to monitor and record the response of the facility to disturbances on the 115 kV system in order to verify the dynamic response of generators. The quantities to be recorded, the sampling rate and the trigger settings will be provided by the transmitter.

Facility Registration/Market Entry Requirements

1. Mathematical models and data, including any controls that would be operational, must be provided to the IESO through the IESO Facility Registration/Market Entry process at least seven months before energization to the IESO-controlled grid. That includes both PSS/E and DSA software compatible mathematical models representing the new equipment for further IESO, NPCC and NERC analytical studies. The *connection applicant* may need to contact the software manufacturers directly, in order to have the models included in their packages

2. The registration of the new facilities will need to be completed through the IESO's Market Entry process before IESO final approval for connection is granted and any part of the facility can be placed in-service. If the data or assumptions supplied for the registration of the facilities materially differ from those that were used for the assessment, then some of the analysis might need to be repeated.

3. As part of the IESO Facility Registration/Market Entry process, the connection applicant must provide evidence to the IESO confirming that the equipment installed meets the Market Rules requirements and matches or exceeds the performance predicted in this assessment. Until this evidence is provided and found acceptable to the IESO, the Facility Registration/Market Entry process will not be considered complete and the connection applicant must accept any restrictions the IESO may impose upon this project's participation in the IESO administered market or connection to the IESO-controlled grid. Failure to provide evidence may result in disconnection from the IESO-controlled grid.

4. During the commissioning period, a set of IESO specified tests must be performed. The commissioning report must be submitted to the IESO within 30 days of the conclusion of commissioning. Field test results should be verifiable using the PSS/E models used for this SIA.

Reliability Standards

Prior to connecting to the IESO controlled grid, the proposed facility must be compliant with the applicable reliability standards set by the North American Electric Reliability Corporation (NERC) and the North East Power Coordinating Council (NPCC). A list of applicable standards, based on the proponent's/connection applicant's market role/OEB license can be found here:

<http://www.ieso.ca/imoweb/ircp/reliabilityStandards.asp>

In support of the NERC standard EOP-005, the proponent/connection applicant may meet the restoration participant criteria. Please refer to section 3 of Market Manual 7.8 (Ontario Power System Restoration Plan) to determine its applicability to the proposed facility.

The IESO monitors and assesses market participant compliance with these standards as part of the IESO Reliability Compliance Program. To find out more about this program, visit the webpage referenced above or write to ircp@ieso.ca.

Also, to obtain a better understanding of the applicable reliability obligations and find out how to engage in the standards development process, we recommend that the proponent/ connection applicant join the IESO's Reliability Standards Standing Committee (RSSC) or at least subscribe to their mailing list at rssc@ieso.ca. The RSSC webpage is located at: http://www.ieso.ca/imoweb/consult/consult_rssc.asp.

- End of Section -

3. Review of Connection Proposal

3.1 Proposed Connection Arrangement

The proposed connection arrangement is shown in Figure 1.

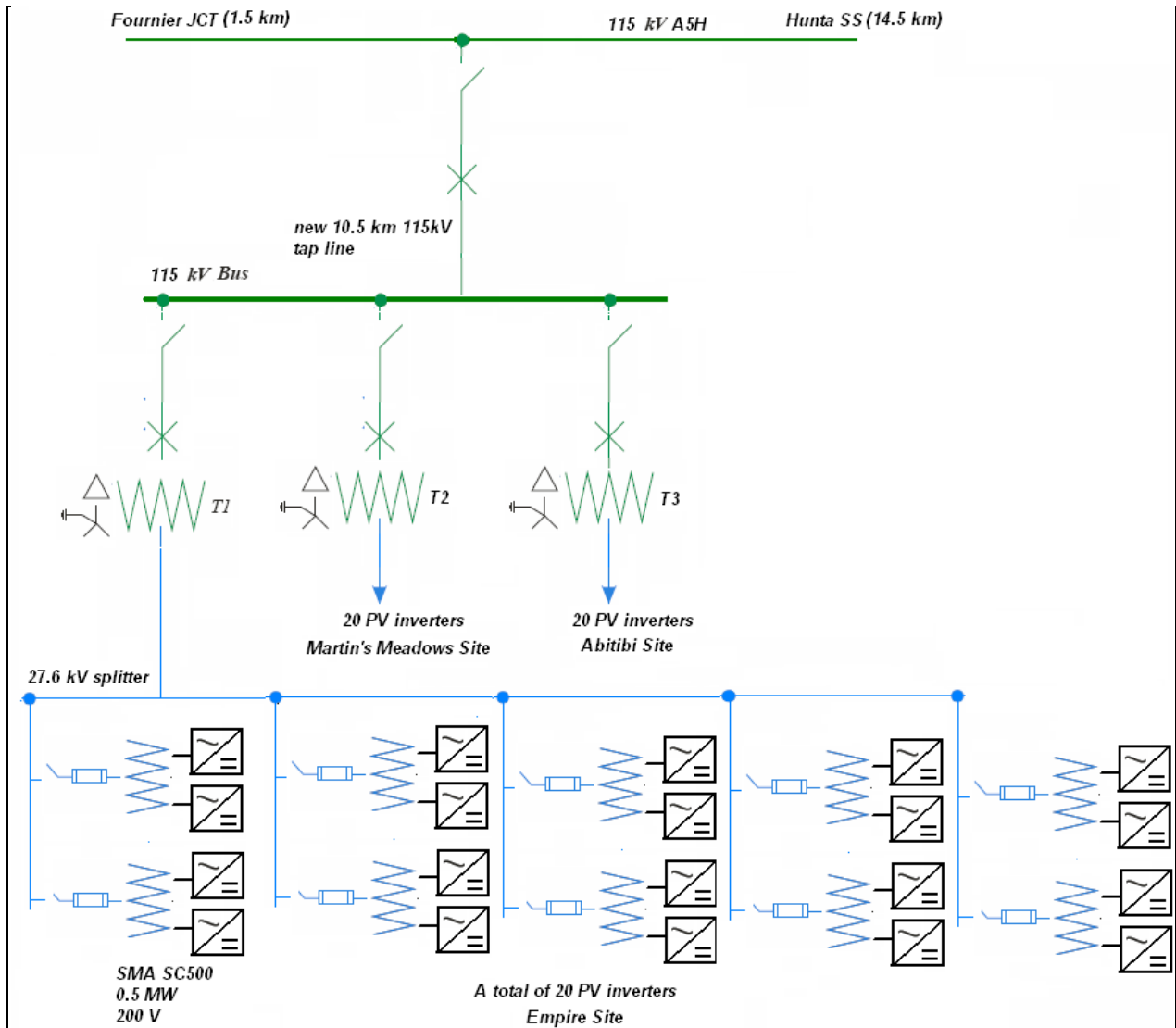

Figure 1: Proposed Connection Arrangement

3.2 Existing System

The solar development is proposing to connect to the existing Hydro One 115 kV A5H circuit between Hunta SS and Fournier JCT. The 115 kV power system around Hunta consists of several existing thermal and hydroelectric generating stations. Major load facilities in the local system include Timmins TS and Falconbridge Kidd Creek Minesite. Under normal daytime operating conditions, the area is over generated with some excess generation being exported through the H6T & H7T circuits into Timmins and in turn, into the 500 kV system through circuits P13T, P15T and the 500/115 kV autotransformers at Porcupine. A diagram of the existing system is shown in Figure 2.

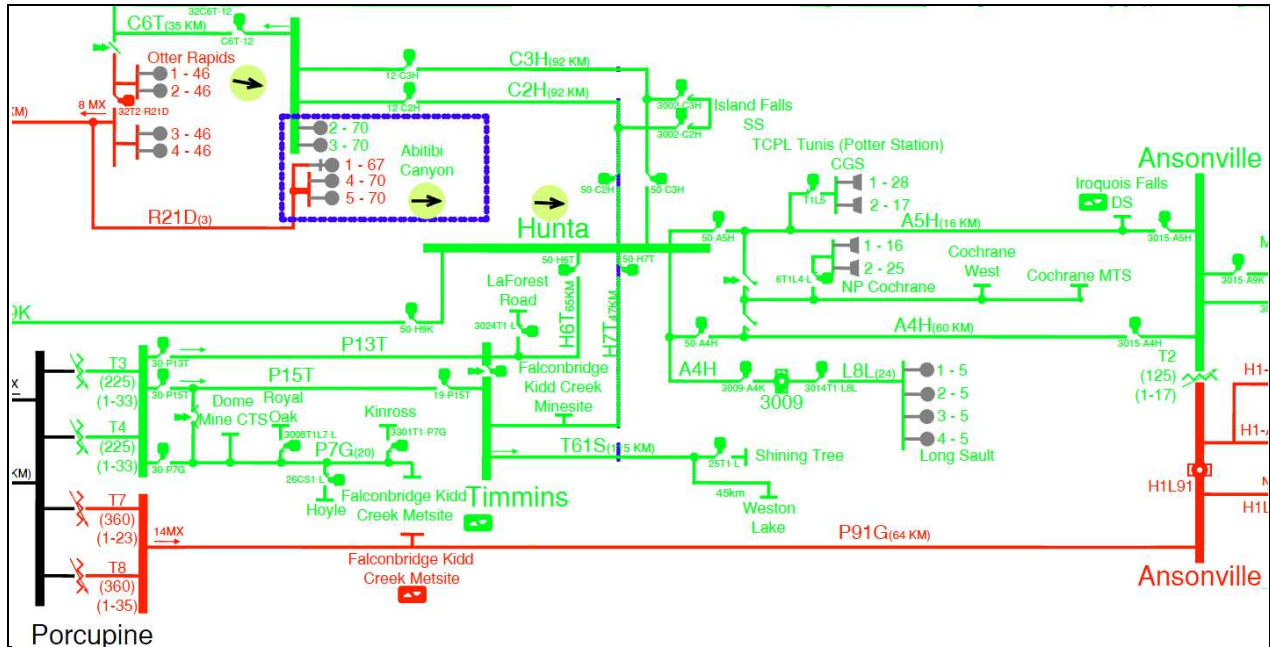

Figure 2: Existing Local Area Power System

3.2.1 Existing & New Generation

Existing generating stations in the local system include Abitibi Canyon 115 kV GS, TCPL Tunis CGS, Northland Power Cochrane and Long Sault Rapids for a total, combined rated active power output of approximately 250 MW. In addition to the existing generating facilities, newly committed generating facilities include the OPG Upper Mattagami Development (Sandy Falls GS, Wawaitin GS and Lower Sturgeon GS) as well as Northland Power Solar Martin’s Meadows/Abitibi/Empire, Northland Power Solar Long Lake and Kapuskasing/Ivanhoe GS, all with scheduled in-service dates prior to 2014. Details regarding existing and newly proposed facilities are outlined in Table 1.

Generating Station	Installed Max. Capacity (MW)	Unit Type	Connection Point
Abitibi Canyon 115 kV GS	140	Hydro	Abitibi Canyon SS
TCPL Tunis CGS	55	Thermal	A5H
NP Cochrane	42	Thermal	A5H/A4H
Long Sault Rapids	16	Hydro	A4H
<i>New:</i> Sandy Falls GS (in-service 2010)	5.5	Hydro	Embedded @ Timmins QZ
<i>New:</i> Wawaitin GS (in-service 2010)	15	Hydro	Embedded @ Timmins QZ
<i>New:</i> Lower Sturgeon GS (in-service 2010)	14	Hydro	Embedded @ Laforest Road

New: NP Solar Martin’s Meadows, Abitibi and Empire (in-service 2012)	30	Solar	A5H
New: NP Solar Long Lake (in-service 2012)	10	Solar	C2H
New: Kapuskasing/Ivanhoe (in-service 2014)	24.55	Hydro	T61S
New: The Chute, Ivanhoe River (in-service 2014)	3.6	Hydro	Embedded @ Weston Lake DS
New: Wanatango Falls (in-service 2014)	4.67	Hydro	Embedded @ Hoyle DS
New: Ramore Solar Park (in-service 2011)	8	Solar	Embedded @ Ramore TS

Table 1: Committed and Existing Local Generation

Figure 3 below displays the total, combined MW output of the Abitibi Canyon 115 kV GS, TCPL Tunis CGS, Northland Power Cochrane and Long Sault Rapids facilities. The data plotted is from January 1, 2009 to March 23, 2010, using hourly average samples obtained from IESO real-time telemetered data. Telemetered data for the new generating facilities as outlined in Table 1 is not available as none of the facilities are in-service yet.

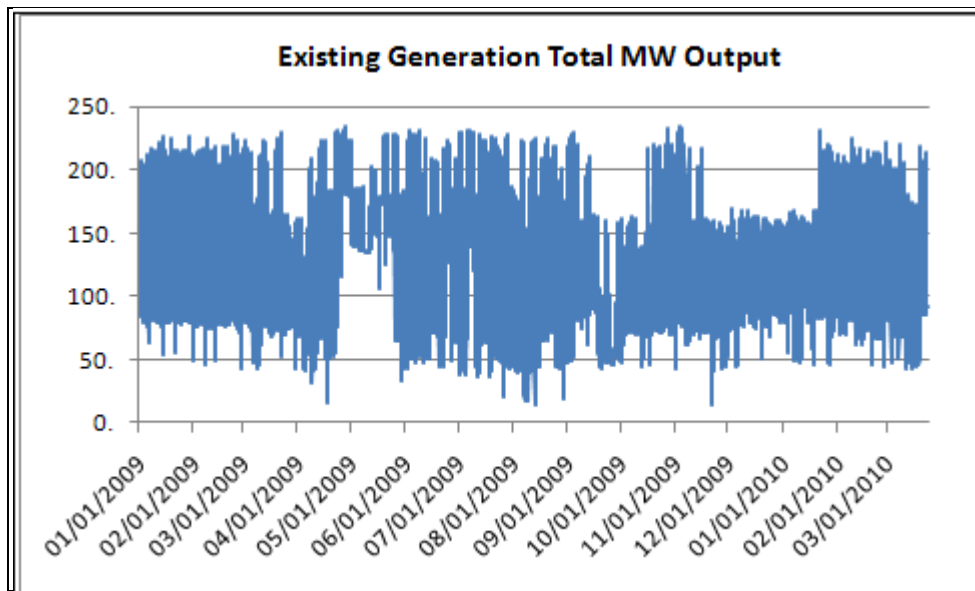

Figure 3: Existing Local Area Generation Telemetered MW Output

It can be observed that the maximum combined MW output of the existing facilities listed in Table 1 is approximately 240 MW. The minimum combined MW output can fall as low as 40 MW. This occurs at night during low demand conditions, when hydroelectric facilities in the North are out-of-service.

3.2.2 Existing Load Facilities

Figures 4-6 below display the MW demand of the major load facilities in the local area from January 1, 2009 to June 1, 2010 and plotted using hourly average samples obtained from IESO real-time telemetered data.

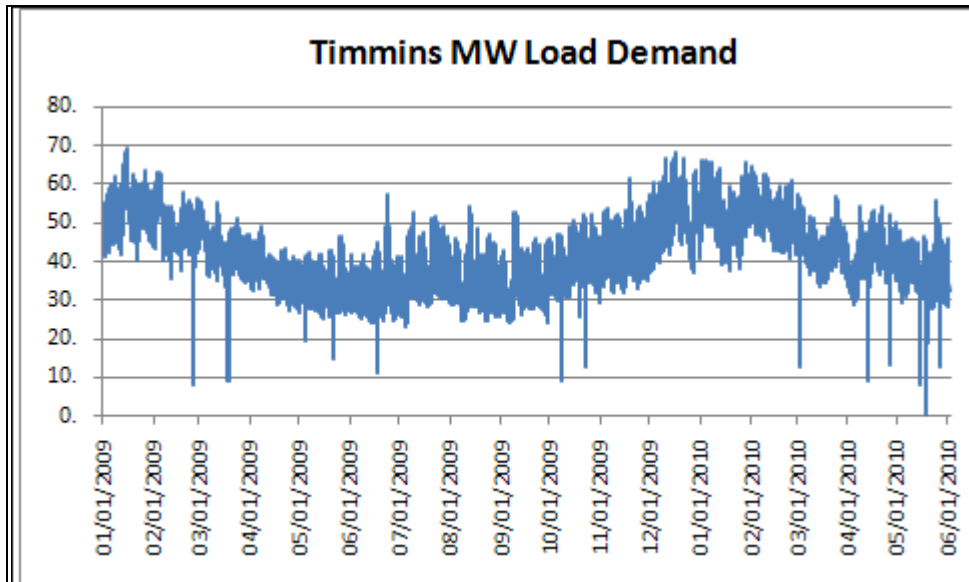

Figure 4: Telemetered Timmins MW Demand

The load behind the Timmins QZ bus varies from a minimum of approximately 30 MW in the summer months to a maximum of approximately 70 MW in the winter months.

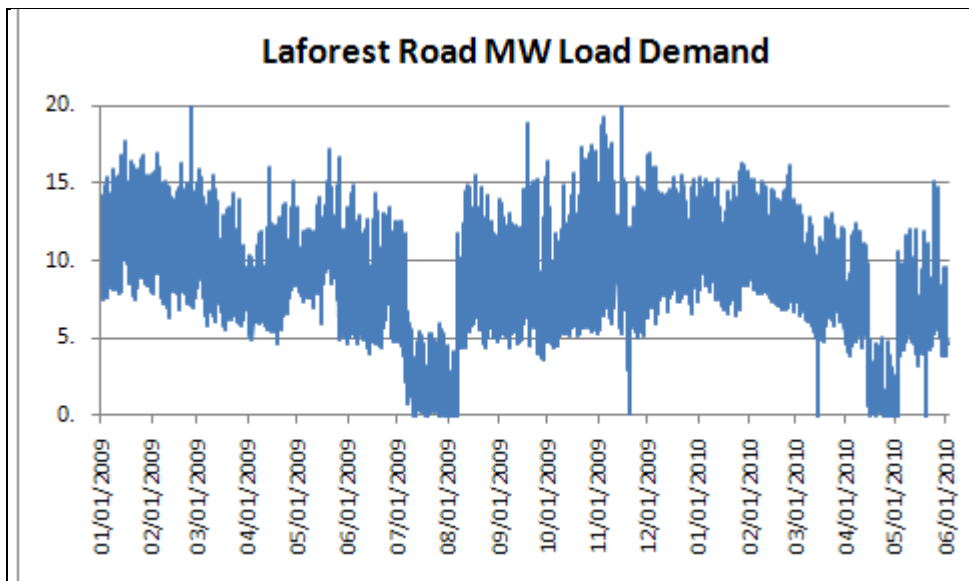

Figure 5: Telemetered Laforest Road MW Demand

When the Laforest Road facility is in-service, its load varies from a minimum of approximately 5 MW to a maximum of approximately 16 MW.

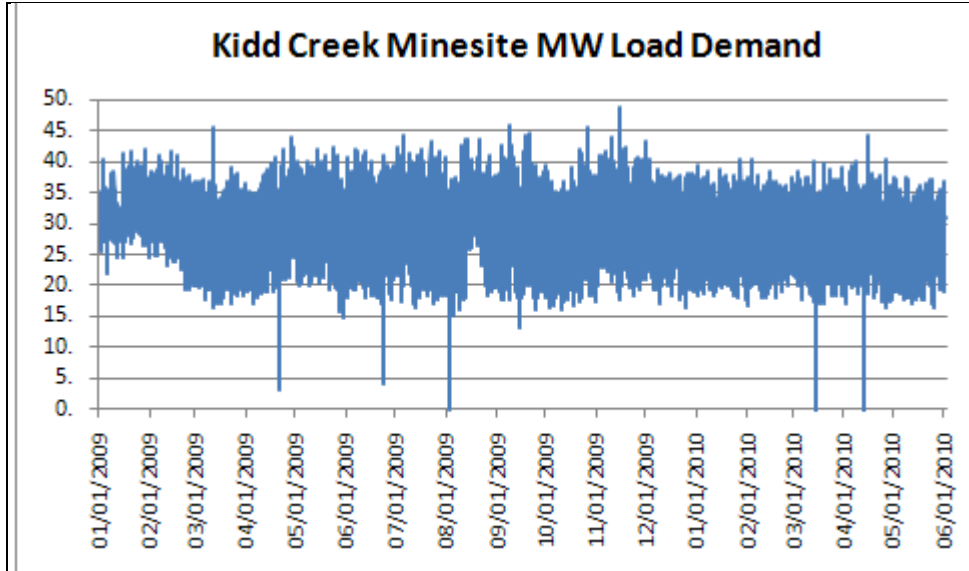

Figure 6: Telemetered Kidd Creek Minesite MW Demand

The load at the Kidd Creek Minesite facility is constant throughout the year and varies from approximately 20 MW to 45 MW.

Table 2 summarizes local load demand values. These values are used to determine the load levels used for various study assumptions as per section 6 of this report.

Station	Maximum Demand (MW)	Minimum Demand (MW)	Average Demand (MW)
Timmins QZ	70	25	Varies Seasonally
Laforest Road	16	5	10
Kidd Creek Minesite	45	17	30

Table 2: Local Load Demand

3.2.3 Existing Transmission

The following are the thermal ratings for all affected transmission equipment in the local area:

Circuit	Section		Continuous		LTE		STE (15 Minute LTR)	
			Amps	MVA	Amps	MVA	Amps	MVA
			A5H	Hunta SS	Fournier JCT	440	89.9	440
	Fournier JCT	EPCOR Tunis JCT	500	102.2	500	102.2	500	102.2
	EPCOR Tunis JCT	Iroquois Falls 115 JCT	500	102.2	530	108.4	540	110.5
	Iroquois Falls 115 JCT	Iroquois Falls DS JCT	380	77.7	490	100.2	580	118.6
	Iroquois Falls DS JCT	Ansonville TS	500	102.2	630	128.8	740	151.3
A4H	Hunta SS	Fournier JCT	260	53.2	260	53.2	260	53.2
	Fournier JCT	Ansonville TS	260	53.2	260	53.2	260	53.2
H7T	Hunta SS	Warkus JCT	500	102.2	530	108.4	530	108.4
	Warkus JCT	Timmins TS	380	77.7	380	77.7	380	77.7
H6T	Hunta SS	Tisdale JCT	500	102.2	530	108.4	530	108.4

	Tisdale JCT	Laforest Road JCT	500	102.2	530	108.4	530	108.4
	Laforest Road JCT	Timmins TS	380	77.7	380	77.7	380	77.7
P15T	Porcupine TS	Timmins TS	890	182.0	1140	233.1	1270	259.7
P13T	Porcupine TS	Timmins TS	890	182.0	1060	216.7	1190	243.3

Table 3: Local Area Equipment Thermal Ratings

The continuous ratings for the conductors were calculated at the lowest of the sag temperature or 93°C operating temperature, with a 30°C ambient temperature and 4 km/h wind speed.

The long term emergency ratings (LTE) for the conductors were calculated at the lowest of the sag temperature or 127°C operating temperature, with a 30°C ambient temperature and 4 km/h wind speed.

The short term emergency ratings (15 Minute LTR) for the conductors were calculated at the sag temperature, with a 30°C ambient temperature, 4 km/h wind speed and 75% continuous preload.

Figures 7 and 8, display the MW flow on circuits H6T and H7T at Hunta and Timmins. These are hourly average samples from Jan 1, 2009 to June 1, 2010 obtained from IESO real-time telemetered data. Positive values mean flow out of the station.

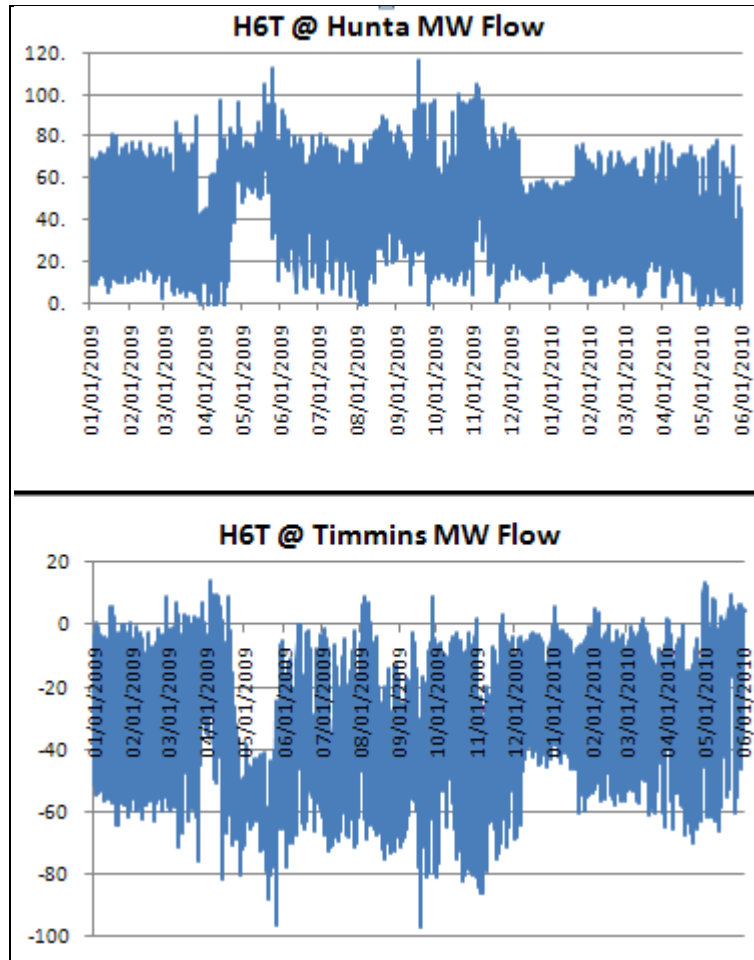

Figure 7: MW Flow on H6T circuit

Maximum loading of the H6T circuit is approximately 100 MW out of Hunta and 80 MW into Timmins. Comparing these flow values with the associated thermal ratings shown in Table 3, shows that the under existing system conditions, the continuous ratings of both sections of the H6T circuit are near or exceed their continuous thermal planning ratings.

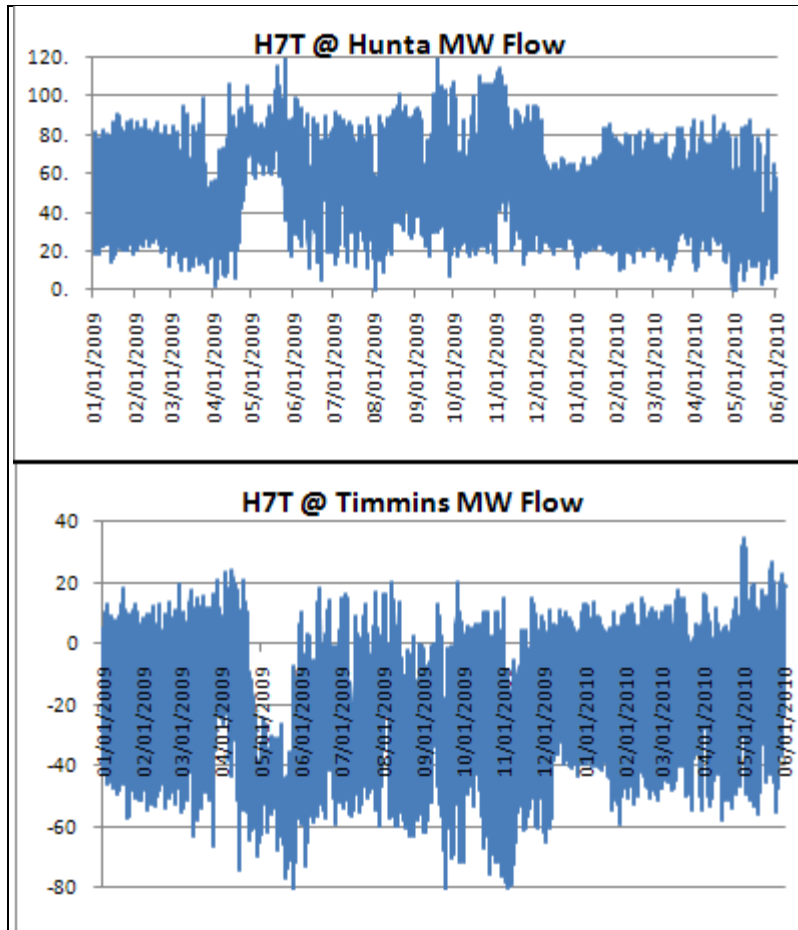

Figure 8: MW Flow on H7T circuit

Maximum loading of the H7T circuit is approximately 110 MW out of Hunta and 80 MW into Timmins. Comparing these flow values with the associated thermal ratings shown in Table 3, shows that under existing system conditions, the continuous ratings of both sections of the H7T circuit are near or exceed their continuous thermal planning ratings.

Figure 9 displays the voltage at Hunta. The data plotted is from March 2009 to June 2010, using hourly average samples obtained from IESO real-time telemetered data. The graph indicates typical voltages of 125-130 kV at Hunta with an average voltage of approximately 127 kV.

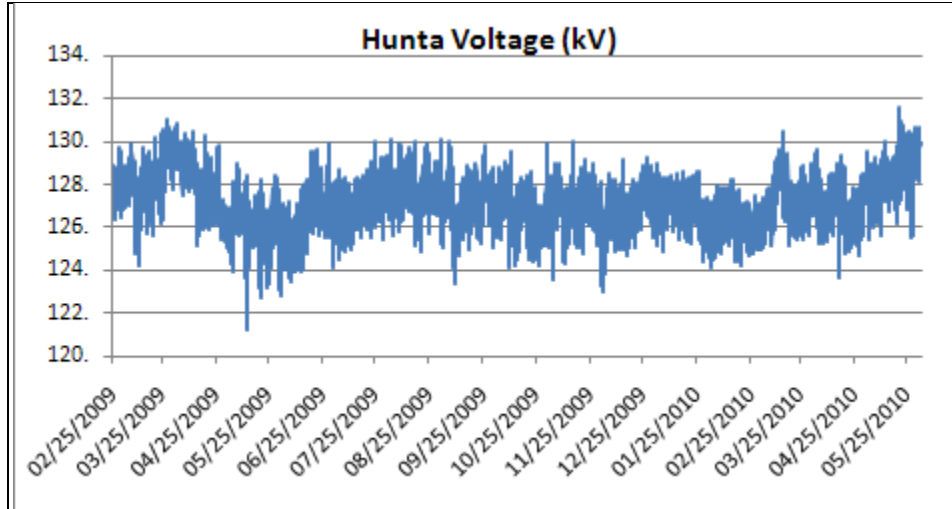

Figure 9: Telemetered Voltage at Hunta

- End of Section -

4. Data Verification

4.1 Tap Line

Specifications of the 115 kV tap line provided by the connection applicant are listed below.

Voltage	115 kV
Length	10.5 km
R/X/B	1.8993/4.7514/0.0000345 Ohms (Mhos)

4.2 Generator

Specifications of the PV Inverter and the inverter step up transformers are listed below.

SMA Sunny Central 500HE-US Photovoltaic Inverter

Voltage	200 V
Rating	0.5 MW
Power Factor	0.95 leading – 0.95 lagging

Three Winding Pad Mount Transformers

	HV1 - LV1	HV1 - LV2	LV1 - LV2
Transformation	27.6 kV – 200V	27.6 kV – 200V	200 V – 200V
X	6.17%	6.17%	3.1%
Base	1.1 MVA	1.1 MVA	1.1 MVA

4.3 Transformer

Specifications for the three 27.6/115 kV step-up transformers are identical and listed below.

Transformation	115/27.6 kV
Rating	9/12 MVA ONAN/ONAF
Impedance	0.0045 + j0.099 pu based on 9 MVA
Configuration	3 phase, high side: delta, low side: grounded wye
Tapping	on-load tap changers at HV (114 kV to 136 kV in 17 steps)

4.4 Circuit Breakers and Switches

Specifications of the isolation devices provided by the connection applicant are listed below.

	Circuit Breakers	Disconnect Switches
Maximum continuous rated voltage (kV)	132	132
Interrupting time (ms)	50	Not Applicable
Rated continuous current (A)	600	600
Rated short circuit breaking current (kA)	45	Not Applicable

The interrupting time of the 115 kV circuit breaker is 50 ms, which satisfies the Transmission System Code requirement of ≤ 5 cycles (83 ms).

The symmetrical rated short circuit breaking current of the 115 kV breakers is 45 kA. This value is below the maximum 3 phase symmetrical fault level of 50 kA established by the Transmission System Code for the 115 kV system. Fault studies shown in Section 5 of this report show that the 115 kV breaker ratings of 45 kA are sufficient to withstand fault levels at the proposed facility. The applicant should be aware that if any future system enhancement results in an increased fault higher than the equipment's capability, the applicant would be required to replace these breakers at its own expense with higher rated breakers up to the maximum fault level of 50 kA.

The 132 kV maximum continuous voltage rating meets IESO connection equipment criteria in Northern Ontario.

4.5 Collector System

The 27.6 kV, collector system equivalent circuit impedances provided by the connection applicant are listed as follows:

Feeder	R/X/B (ohms/mhos)
Empire Site	2.073/0.5127/0.000145
Martin's Meadows Site	2.073/0.5127/0.000145
Abitibi Site	2.073/0.5127/0.000145

– End of Section –

5. Fault Level Assessment

Fault level studies were completed by Hydro One to examine the effects of the proposed facility on fault levels at existing facilities in the area. Studies were performed to analyze the fault levels with and without the new facility and other proposed projects in the surrounding area. The short circuit study was carried out with the following facilities and system assumptions:

Niagara, South West, West Zones

- All hydraulic generation
- 6 Nanticoke
- 2 Lambton
- Brighton Beach (J20B/J1B)
- Greenfield Energy Centre (Lambton SS)
- St. Clair Energy Centre (L25N & L27N)
- East Windsor Cogen (E8F & E9F) + existing Ford generation
- TransAlta Sarnia (N6S/N7S)
- Imperial Oil (N6S/N7S)
- Thorold GS (Q10P)

Central, East Zones

- All hydraulic generation
- 6 Pickering units
- 4 Darlington units
- 4 Lennox units
- GTAA (44 kV buses at Bramalea TS and Woodbridge TS)
- Sithe Goreway GS (V41H/V42H)
- Portlands GS (Hearn SS)
- Kingston Cogen
- TransAlta Douglas (44 kV buses at Bramalea TS)

Northwest, Northeast Zones

- All hydraulic generation
- 1 Atikokan
- 2 Thunder Bay
- NP Iroquois Falls
- AP Iroquois Falls
- Kirkland Lake
- 1 West Coast (G2)
- Lake Superior Power
- Terrace Bay Pulp STG1 (embedded in Neenah paper)

Bruce Zone

- 8 Bruce units (Bruce G1 and Bruce G2 maximum capacity @ 835 MW)
- 4 Bruce B Standby Generators

All constructed wind farms including

- Erie Shores WGS (WT1T)
- Kingsbridge WGS (embedded in Goderich TS)

- Amaranth WGS – Amaranth I (B4V) & Amaranth II (B5V)
- Ripley WGS (B22D/B23D)
- Prince I & II WGS (K24G)
- Underwood (B4V/B5V)
- Kruger Port Alma (C24Z)
- Wolf Island (injecting into X4H)

New Generation Facilities:

- Greenwich Wind Farm (M23L and M24L)
- Gosfield Wind Project (K2Z)
- Kruger Energy Chatham Wind Project (C24Z)
- Raleigh Wind Energy Centre (C23Z)
- Talbot Wind Farm (W45LC)
- Greenfield South GS (R24C)
- Halton Hills GS (T38B/T39B)
- Oakville Generating Station (B15C/B16C)
- York Energy Centre (B82V/B83V)
- Island Falls (H9K)
- Becker Cogeneration (M2W)
- Wawatay G4 (M2W)
- Beck 1 G9: increase capacity to 68.5 MVA (Beck #1 115 kV bus)
- Lower Mattagami Expansion
- All renewable generation projects awarded FIT contracts

Transmission System Configuration

Existing system with the following upgrades:

- Bruce x Orangeville 230 kV circuits up-rated
- Burlington TS: Rebuild 115 kV switchyards
- Leaside TS to Birch JCT: Build new 115 kV circuit. Birch to Bayfield: Replace 115 kV cables.
- Uprate circuits D9HS, D10S and Q11S
- Hurontario SS in service with R19T+V41H open from R21T+V42H (230 kV circuits V41H and V42H extended and connected from Cardiff TS to Hurontario SS). Hurontario SS to Jim Yarrow 2x3km 230 kV circuits in-service
- Cherrywood TS to Claireville TS: Unbundle the two 500 kV super-circuits (C551VP & C550VP)
- Allanburg x Middleport 230 kV circuits (Q35M and Q26M) installed
- Claireville TS: Reterminate circuit 230 kV V1RP to Parkway V71P Reterminate circuit 230 kV V72R to Cardiff(V41H)
- One 250 Mvar (@ 250 kV) shunt capacitor bank installed at Buchanan TS
- LV shunt capacitor banks installed at Meadowvale
- 1250 MW HVDC line ON-HQ in service
- Tilbury West DS second connection point for DESN arrangement using K2Z and K6Z
- Second 500kV Bruce-Milton double-circuit line in service. Double-circuit line from the Bruce Complex to Milton TS with one circuit originating from Bruce A and the other from Bruce B
- Windsor area transmission reinforcement:
 - 230 kV transmission line from Sandwich JCT (C21J/C22J) to Lauzon TS
 - New 230/27.6 DESN, Leamington TS, that will connect C21J and C22J and supply part of the existing Kingsville TS load

- Replace Keith 230/115 kV T11 and T12 transformers
- 115 kV circuits J3E and J4E upgrades
- Woodstock Area transmission reinforcement:
 - Karn TS in service and connected to M31W & M32W at Ingersol TS
 - W7W/W12W terminated at LaFarge CTS
 - Woodstock TS connected to Karn TS
- Nanticoke and Detweiler SVCs
- Series capacitors at Nobel SS in each of the 500 kV circuits X503 & X504E to provide 50% compensation for the line reactance
- Lakehead TS SVC
- Porcupine TS & Kirkland Lake TS SVC
- Porcupine TS: Install 2x125 Mvar shunt capacitors
- Essa TS : Install 250 Mvar shunt capacitor
- Hanmer TS: Install 149 Mvar shunt capacitor
- Pinard TS: Install 2x30 Mvar LV shunt capacitors
- Upper Mattagami expansion
- Fort Frances TS: Install 22 Mvar moveable shunt capacitor
- Dryden TS: Install shunt capacitors
- Lower Mattagami Expansion – H22D line extension from Harmon to Kipling.

System Assumptions

- Lambton TS 230 kV operated open
- Claireville TS 230 kV operated open
- Leaside TS 230 kV operated open
- Leaside TS 115 kV operated open
- Middleport TS 230 kV bus operated open
- Hearn SS 115 kV bus operated open – as required in the Portlands SIA
- Napanee TS 230 kV operated open
- Cherrywood TS north & south 230kV buses operated open
- Cooksville TS 230 kV bus operated open
- Richview TS 230 kV bus operated open
- All capacitors in service
- All tie-lines in service and phase shifters on neutral taps
- Maximum voltages on the buses
- Contact parting time = 25 ms for 500 kV and 230 kV breakers
- Contact parting time = 33 ms for 115 kV breakers

The following table summarizes the symmetric and asymmetrical fault levels near Hunta and the corresponding breaker ratings.

Bus	Solar Farm O/S		Solar Farm I/S		Breaker Ratings Symmetrical (kA)
	Total Fault Current Symmetrical (kA)		Total Fault Current Symmetrical (kA)		
	3-phase	L-G	3-phase	L-G	
Hunta	9	5.8	9.4	5.9	40
Abitibi Canyon 115 kV	5.6	5.8	5.7	5.8	9.8
Ansonville 115 kV	8.4	8.9	8.6	9.0	40
Timmins K1	8.8	8.8	9.1	9.0	40
Timmins K2 + K3	8.8	8.9	9.3	9.2	40
Porcupine 115kV	10.5	13.3	11.0	13.8	40
NP Solar A5H Tap	-	-	6.8	4.1	45

Bus	Solar Farm O/S		Solar Farm I/S		Breaker Ratings Asymmetrical (kA)
	Total Fault Current Asymmetrical (kA)		Total Fault Current Asymmetrical (kA)		
	3-phase	L-G	3-phase	L-G	
Hunta	9.4	6.0	9.8	6.2	48
Abitibi Canyon 115 kV	6.4	7.0	6.5	7.1	11.4
Ansonville 115 kV	9.5	10.4	9.6	10.5	40
Timmins K1	9.7	9.6	10.1	9.8	40
Timmins K2 + K3	9.7	9.7	10.3	10.1	40
Porcupine 115kV	12.4	16.6	13.0	17.2	47
NP Solar A5H Tap	-	-	7.1	4.2	45

Table 4: Short Circuit Study Results

The results show that the fault levels around the Hunta power system are below the symmetrical/asymmetrical breaker ratings and increase slightly when all new generation is in service.

Therefore, it can be concluded that the increases in fault levels due to the proposed projects will not exceed the interrupting capabilities of the existing breakers on the IESO-controlled grid.

The proposed breakers at the solar farm and the existing breakers at local area buses are capable of interrupting the expected short circuit levels on the IESO controlled grid. No short circuit issues are foreseen with the incorporation of the proposed project.

– End of Section –

6. System Impact Studies

This connection assessment was carried out to identify the effect of the proposed facility on the thermal loading of transmission interfaces in the vicinity, the system voltages for pre/post contingencies, the ability of the facility to control voltages and the transient performance of the system.

6.1 Assumptions and Background

Summer 2014 conditions were used for the study, along with the following assumptions:

System Conditions

All transmission system elements were in service.

Stations in the area were set to operate at 0.9 load power factors measured at the HV side of the transformers.

The demand in the Northeast area was scaled to 1200 MW.

Study Assumptions

The summer 2010 base case was used as a starting point for the studies. To the summer 2010 original case, the following new projects were added and considered in-service as part of the Flow South expansion:

- Lower Mattagami Generation Development connected to Pinard 230 kV
- All new committed generation as outlined in Section 3.2.1, Table 1
- Series Compensation of X503E and X504E circuits
- +300/-100 Mvar SVC at Porcupine 230 kV
- +200/-100 Mvar SVC at Kirkland Lake 115 kV
- Shunt Capacitor Banks at Pinard 27.6 kV bus (2 x 32.4 Mvar @ 27.6 kV)
- Second Shunt Capacitor Bank at Hanmer 230 kV bus (149 Mvar @ 220 kV)
- Second Shunt Capacitor Bank at Essa 230 kV bus (245 Mvar @ 250 kV)
- Shunt Capacitor Banks at Porcupine 230 kV bus (2 x 100 Mvar @ 250 kV)
- Shunt Capacitor Bank at Kapuskasing 24.9 kV bus (21.6 Mvar @ 28.8 kV)

The following reactors were removed from service to help maximize power transfers:

- Pinard Reactors R1 and R2
- Hanmer Reactors R6, R7, R8 and R9
- Essa Reactors R3 and R4

Existing Hanmer Reactors R1 and R2 were left in-service due to the inability of switching these reactors in and out of service on-load.

Existing 5 Mvar capacitors SC3 and SC4 at Hearst TS were assumed out of service to avoid pre-contingency overvoltages at Hearst TS.

An over generated northern system scenario was studied to maximize the Flow South transfer. The generation in the Northeast is maximized to obtain the following power transfers pre-contingency. These are the base assumptions used for all studies.

Interface	Transfer Used in Studies (MW)	Study Limit* (MW)
East West Transfer East (EWTE)	325	355
Mississagi Flow East (MISSE)	600	715
Flow South (FS)	2060	2250**
Flow into Hanmer on P502X	1300	-

Table 5: Power Transfer Study Assumptions

* Study Limit = Operating Limit + 10%

** Preliminary limit derived assuming reactors R1 and R2 at Hanmer out-of-service

The transfers through the FS interface and on 500 kV circuit P502X reflect the expected expanded values for these interfaces with the above system configuration assumptions.

In addition to the above pre-contingency limits, the following limits were observed for post-contingency analysis:

Interface	Limit (MW)	Contingency
Flow on A8K + A9K @ Ansonville	40 South / 50 North	Loss of P502X
Flow through Spruce Falls T7	75 South/ 50 North	Loss of D501P
Flow on H9K @ Hunta	80	Loss of D501P

Table 6: Applicable Post-Contingency Limits

Study Scenarios

The assessment was completed trying to incorporate all existing and committed local generation at their maximum rated MW output. The following are the MW dispatches of all local generation and major load facilities:

Generating Station	Output (MW)
Abitibi Canyon 115 kV GS	140
TCPL Tunis CGS	55
NP Cochrane	42
Long Sault Rapids	16
Sandy Falls GS	5.5
Wawaitin GS	15
Lower Sturgeon GS	14
NP Solar Martin's Meadows, Abitibi and Empire	30
NP Solar Long Lake	10
Kapuskasing/Ivanhoe	24.55
The Chute, Ivanhoe River	3.6
Wanatango Falls	4.67
Ramore Solar Park	8

Station	Demand (MW)
Timmins QZ	45
Laforest Road	10
Kidd Creek Minesite	30

Table 7: Local Area Generation and Load Dispatch

To accommodate all new local generation while still respecting system flow limits through the Flow South interface and the P502X circuit (as outlined in Table 5), generation at the expanded Lower Mattagami facility had to be dispatched down.

Due to system limitations, accommodating full generation capacity from the Northeast region will not be possible. To increase generation capacity, it is recommended that Hydro One explore the feasibility of making reactors R1 and R2 at Hanmer capable of being switched in and out of service on-load. This will increase transfer capability through the P502X circuit and the Flow South interface.

Two different connection arrangements were studied:

Normal Arrangement – Tunis GS connected to A5H, Cochrane GS & Long Sault Rapids connected to A4H

Alternate Arrangement – Tunis GS & Cochrane GS connected to A5H, Long Sault Rapids connected to A4H

Both Normal and Alternate Arrangements were considered for thermal analysis. Only the Normal Arrangement was studied for voltage and transient studies.

6.2 Protection Impact Assessment

A Protection Impact Assessment (PIA) was completed by Hydro One to examine the impact of the new generation facility on existing transmission system protections. The existing protections for circuit A5H at the solar farm were described in the PIA report and the proposed protection settings were analyzed based on preliminary fault calculations. Finally, the proposed protection solutions and recommendations were presented.

The connection of the proposed facility will require the revision of zone 2 protections reach settings at Hunta SS and Ansonville TS as well as a new telecommunication link(s) to transmit protection signals amongst existing stations. A copy of the Protection Impact Assessment summary can be found in Appendix B of this report.

The IESO concluded that the proposed protection adjustments have no material adverse impact on the reliability of the IESO-controlled grid.

6.3 Reactive Power Compensation

Market Rules require that generators inject or withdraw reactive power continuously (i.e. dynamically) at a connection point up to 33% of its rated active power at all levels of active power output except where a lesser continually available capability is permitted by the IESO.

The Market Rules accepts that a generating unit with a power factor range of 0.90 lagging and 0.95 leading at rated active power connected via a main output transformer impedance not greater than 13% based on generator rated apparent power provides the required range of dynamic power at the connection point.

Typically, the impedance between the PV inverter and the connection point is larger than 13%. However, provided the PV inverter has the capability to provide a reactive power range of 0.90 lagging power factor

and 0.95 leading power factor at rated active power, the IESO accepts the PV inverter to compensate for the full reactive power requirement range at the connection point with switchable shunt admittances (e.g. capacitors and reactors). Where the PV inverter has no capability to supply the full dynamic reactive power range at its terminal, the shortfall has to be compensated with dynamic reactive power devices (e.g. SVC, Statcom).

This section of the SIA indicates how the Solar Farm can meet the Market Rules requirements regarding reactive power capability, but the connection applicant is free to deploy any other solutions which result in its compliance with the Market Rules.

It is the connection applicant's responsibility to ensure that the Solar Farm has the capability to meet the Market Rules requirement at the connection point and be able to confirm this capability during the commission tests.

6.3.1 Dynamic Reactive Power Compensation

The following table summarizes the IESO's adequate level of reactive power from each generator and the available capability of SMA SC500HE-US PV inverter, at rated terminal voltage and rated power.

	Rated Voltage	Rated Active Power	Reactive Power Capability	Total Facility Output	Power Factor
IESO Requirements	200 V	0.5 MW	$Q_{\max} = 0.5 \times \tan [\cos^{-1} (0.9)] = 0.242 \text{ Mvar}$	$60 \times 0.242 = +14.5 \text{ Mvar}$	0.9 lag
			$Q_{\min} = 0.5 \times \tan [\cos^{-1} (0.95)] = 0.164 \text{ Mvar}$	$60 \times 0.164 = -9.4 \text{ Mvar}$	0.95 lead
SC500HE-US (Existing Capability)	200 V	0.5 MW	$Q_{\max} = 0.164 \text{ Mvar}$	$60 \times 0.164 = +9.4 \text{ Mvar}$	0.95 lag
			$Q_{\min} = 0.164 \text{ Mvar}$	$60 \times 0.164 = -9.4 \text{ Mvar}$	0.95 lead
SC500HE-US (Future Capability)	200 V	0.5 MW	$Q_{\max} = 0.242 \text{ Mvar}$	$60 \times 0.242 = +14.5 \text{ Mvar}$	0.90 lag
			$Q_{\min} = 0.242 \text{ Mvar}$	$60 \times 0.242 = -14.5 \text{ Mvar}$	0.90 lead

Table 8: Inverter Dynamic Reactive Power Requirements & Capability

The existing model of the SC500HE-US inverter has a dynamic reactive power capability of 0.95 lead – 0.95 lag. Future implementations of the SC500HE-US inverter will have a dynamic reactive power capability of 0.9 lead – 0.9 lag. SMA has indicated that this enhanced model will become available by the end of 2010.

With existing SMA models of the SC500HE-US inverter, a dynamic reactive power device (SVC/Statcom) with a capability of **+5.1 Mvar** has to be installed at the facility to compensate for the dynamic reactive power deficiency of the facility. The location of this device can be at the facility 115 kV overhead bus or at one of the LV collector buses.

Should future enhancements of the SC500HE-US inverter provide an increased dynamic reactive power range of 0.9 leading – 0.9 lagging (as indicated by SMA), the applicant must communicate the inverter reactive power capability changes to the IESO to allow for reassessment of reactive power requirements.

6.3.2 Static Reactive Power Compensation

In addition to the dynamic reactive power requirement identified above, the Solar Farm has to compensate for the reactive power losses within the facility to ensure that it has the capability to inject or withdraw reactive power up to 33% of its rated active power at the connection point. As mentioned above, the IESO accepts this compensation to be made with switchable shunt admittances.

Load flow studies were performed to calculate the need for static reactive compensation, based on the equivalent parameters for the Solar Farm provided by the connection applicant.

The reactive power capability in lagging p.f. of the generation facility was assessed under the following assumptions:

- typical voltage of 127 kV at the connection point;
- maximum active power output from the equivalent Solar Farm;
- maximum reactive power output (lagging power factor) from the required dynamic reactive compensation device;
- the main step-up transformer ULTC is available to adjust the LV voltage as close as possible to 1 pu voltage.

The reactive power capability in leading p.f. of the generation facility was assessed under the following assumptions:

- typical voltage of 127 kV at the connection point;
- minimum (zero) active power output from the equivalent Solar Farm;
- maximum reactive power consumption (leading power factor) from the required dynamic reactive compensation device;
- the main step-up transformer ULTC is available to adjust the LV voltage as close as possible to 1 pu voltage.

The IESO's reactive power calculation used the equivalent electrical model for the Solar Farm and collector feeders as provided by the connection applicant. It is very important that the Solar Farm has proper internal design to ensure that the WTG are not limited in their capability to produce active and reactive power due to terminal voltage limits or other facility's internal limitations. For example, it is expected that the transformation ratio of the WTG step up transformers will be set in such a way that it will offset the voltage profile along the collector, and all the WTG would be able to contribute to the reactive power production of the WF in a shared amount.

Based on the equivalent parameters for the SF as provided by the connection applicant, a lagging reactive power deficiency of approximately **+1 Mvar** exists for the total facility. Due to the relatively small size of the deficiency, the required static compensation can be added to the size of the SVC to provide a total of **+6 Mvar** of dynamic reactive compensation for the entire facility.

The connection applicant has the obligation to ensure that the SF design and the reactive power compensation system takes into account the real electrical parameters and real limitations within the SF facility.

6.4 Solar Farm Management System

For any generating facility connecting to the IESO-controlled grid, the IESO requires that the facility assists in maintaining voltages in the high voltage system. It is expected that the solar farm controls the voltage at a point as close as possible to the connection point to values specified by the IESO. This requires that solar farms possess the ability to supply/absorb sufficient dynamic reactive power to the high voltage system during voltage declines/rises.

The generation facility shall regulate automatically voltage at a point whose impedance (based on rated apparent power and rated voltage) is not more than 13% from the highest voltage terminal based within $\pm 0.5\%$ of any set point within $\pm 5\%$ of rated voltage. If the AVR target voltage is a function of reactive output, the slope $\Delta V / \Delta Q_{\max}$ shall be adjustable to 0.5%.

The Solar Farm Management System (SFMS) must coordinate the voltage control process. The proponent has selected the following process:

- (1) All PV inverters control the PCC voltage to a reference value. A control slope is applied for reactive power sharing among the PV inverters as well as with adjacent generators.
- (2) SF main transformer ULTC is adjusted to regulate the collector bus voltage (LV bus voltage) such that it is within normal range;

The proponent must submit a description of the functionalities of the SFMS, including the coordination between the transformer ULTC and PV inverter reactive power production to control the voltage at a desired point. If the SFMS is unavailable, the IESO requires that each PV inverter control its own terminal voltage.

To provide performance benchmarking for the type of var response times expected from a solar facility operating in voltage control mode, studies were performed to simulate the var response time to a change in reference voltage of the AVR in a typical hydroelectric facility. The facility collector system was modelled as per the SIA application, the PV inverters were replaced with minimum IESO acceptable default parameters of a salient pole machine, excitation system and power system stabilizer. At time $t=0$, the reference voltage of the machine bus terminals was changed from 1.00 to 1.05 pu, the var response of the entire facility was monitored at the connection point. Study results are shown on Figure 10.

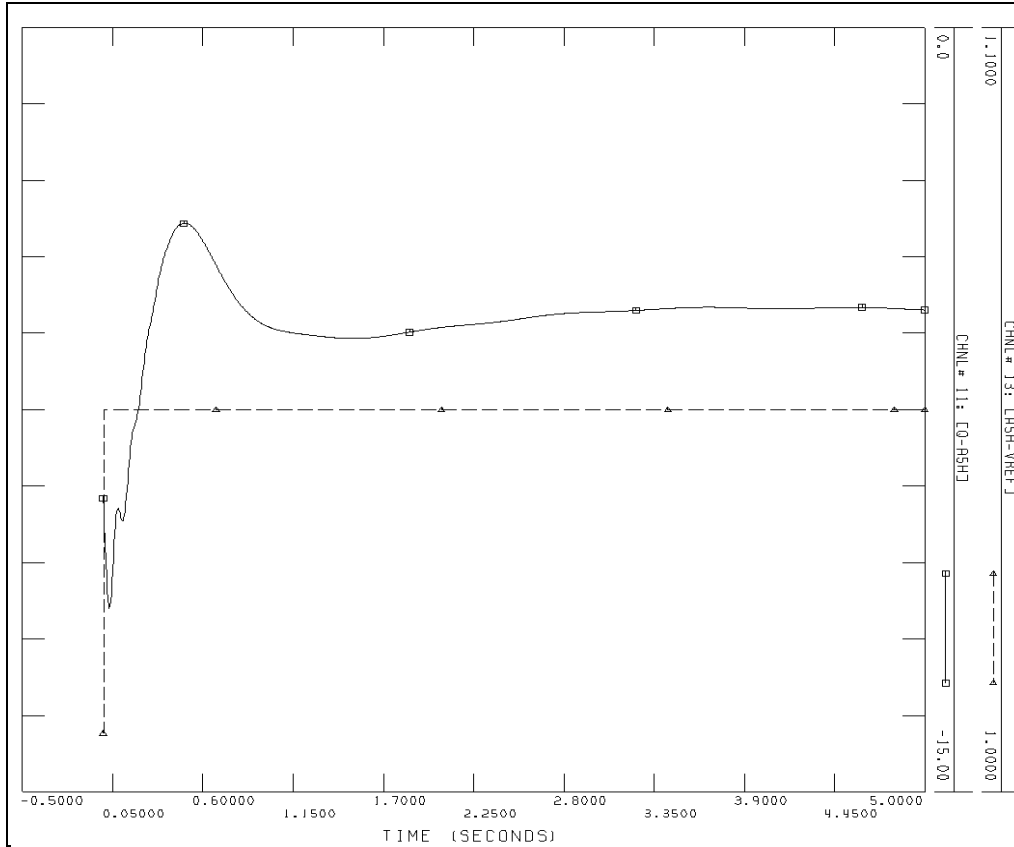

Figure 10: VAR Response Time of Minimum Acceptable Hydroelectric Facility

The generator responds to an increase in reference voltage by increasing its reactive power output in order to achieve the new desired set point in generator terminal voltage. The response time is shown to be approximately 0.55 sec from the time the reference voltage is changed.

The response time of inverter var output to changes in AVR reference voltages must be minimal and similar to conventional generator technologies. Simulations using minimum acceptable default parameters of a hydroelectric facility in place of the PV inverters yielded a var response time of approximately 0.55 sec. The connection applicant is required to have similar or better var response time performance.

6.5 Thermal Analysis

The thermal assessment examined the effects of the proposed facility on the thermal loadings of the Hunta, Timmins and Porcupine 115 kV transmission system.

The *Ontario Resource and Transmission Assessment Criteria* requires that all line and equipment loading to be within their continuous ratings with all elements in service, and within their long-term emergency ratings with any element out of service. Lines and equipment may be loaded up to their short-term emergency ratings immediately following the contingencies to effect re-dispatch, perform switching, or implement control actions to reduce the loading to the long-term emergency ratings.

The following are the pre-contingency flows for the various 115 kV circuits in the local area, before and after the solar development is incorporated into the system:

CCT	Section		Continuous Rating		Normal Arrangement				Alternate Arrangement			
					NP A5H Solar Development Out of Service		NP A5H Solar Development In-Service		NP A5H Solar Development Out of Service		NP A5H Solar Development In-Service	
	From	To	Amps	MVA	Amps	%	Amps	%	Amps	%	Amps	%
A5H	Hunta SS	Fournier JCT	440	89.9	64	14	44	10	60	13	141	32
	Fournier JCT	E. Tunis JCT	500	102.2	64	12	109	21	97	19	143	28
	E. Tunis JCT	Ir. Falls 115 JCT	500	102.2	312	62	359	71	346	69	393	78
	Ir. Falls 115 JCT	Ir. Falls DS JCT	380	77.7	312	82	359	94	346	91	393	103
	Ir. Falls DS JCT	Ansonville TS	500	102.2	300	60	347	69	335	67	382	76
A4H	Hunta SS	Fournier JCT	260	53.2	26	10	38	14	132	50	144	55
	Fournier JCT	Ansonville TS	260	53.2	167	64	179	68	131	50	143	55
H7T	Hunta SS	Warkus JCT	500	102.2	457	91	486	97	457	91	486	97
	Warkus JCT	Timmins TS	380	77.7	336	88	364	95	336	88	364	95
H6T	Hunta SS	Tisdale JCT	500	102.2	412	82	441	88	412	82	441	88
	Tisdale JCT	Laforest Rd JCT	500	102.2	407	81	436	87	407	81	436	87
	Laforest Rd JCT	Timmins TS	380	77.7	428	112	457	120	428	112	457	120
P15T	Porcupine TS	Timmins TS	890	182.0	360	40	389	43	360	40	389	43
P13T	Porcupine TS	Timmins TS	890	182.0	415	46	442	49	415	46	443	49

Table 9: Pre-Contingency Thermal Results

The study results show congestion exists with sections of the H6T and H7T circuits. These congestion issues exist during day time conditions, when all local area generation is in-service causing high power transfers through the 115 kV system. The connection of the Northland Power Martin’s Meadows, Abitibi and Empire development increases the flows on the H6T and H7T circuits and thus increases congestion. Accommodating full generation output from all local generation will not be possible.

Congestion on the H6T circuit was identified with all local area generation in-service and operating near their maximum installed capacity. The incorporation of the proposed project will increase congestion. It is required that Hydro One upgrade 115 kV circuit H6T from Laforest Road JCT to Timmins TS and 115 kV circuit H7T from Warkus JCT to Timmins TS as soon as practical to help alleviate congestion. Connection to the grid of the proposed facility is not dependent on the implementation of this requirement.

The study results also identified congestion on the A5H circuit under the Alternate Connection Arrangement when the new facility is at full output and existing Tunis and Cochrane generating stations are both connected to circuit A5H, operating near their full rated capacity.

Congestion issues were identified trying to accommodate full output from the new SF when Tunis GS and Cochrane GS are both connected to circuit A5H. Operating restrictions will need to be implemented to avoid the simultaneous connection of the three facilities to the A5H circuit when all units are operating near their full MW capacity.

To alleviate congestion, Northeast generation was re-dispatched so that pre-contingency power flows on the H6T and H7T circuits were below their continuous ratings. In particular, Lower Sturgeon GS was placed out of service while generation at Abitibi Canyon 115 kV GS and NP Cochrane was reduced. The following outlines the local generation dispatch used in this non-congested case:

Generating Station	Output (MW)
Abitibi Canyon 115 kV GS	120
TCPL Tunis CGS	55
NP Cochrane	38
Long Sault Rapids	16
Sandy Falls GS	5.5
Wawaitin GS	15
Lower Sturgeon GS	Out of service
NP Solar Martin's Meadows, Abitibi and Empire	30
NP Solar Long Lake	10
Kapuskasing/Ivanhoe	24.55
The Chute, Ivanhoe River	3.6
Wanatango Falls	4.67
Ramore Solar Park	8

Table 10: Local Area Generation Dispatch Used for Post-Contingency Thermal Studies

Using this non-congested case with the Normal Connection arrangement, contingency studies were performed to identify potential post-contingency thermal violations. The following summarizes the pre-contingency and post-contingency flows for the 115 kV circuits in the local system. The pre-contingency flow on each circuit is expressed in amperes and percentage of continuous rating. The post-contingency loadings of the monitored circuits include loading in amperes, and percentage of loading of the LTE and STE.

CCT	Section		Cont. Rating	LTE	STE	Pre-Contingency		Loss of A4H			Loss of H6T ⁽¹⁾			Loss of H7T ⁽²⁾			Loss of P91G ⁽³⁾		
	From	To	Amps	Amps	Amps	Amps	Cont %	Amps	LTE %	STE %	Amps	LTE %	STE %	Amps	LTE %	STE %	Amps	LTE %	STE %
A5H	Hunta SS	Fournier JCT	440	440	440	59	13	25	5	5	178	40	40	139	31	31	133	30	30
	Fournier JCT	E. Tunis JCT	500	500	500	90	18	137	27	27	178	35	35	139	27	27	133	26	26
	E.Tunis JCT	Ir. Falls 115 JCT	500	530	540	339	67	389	73	72	179	33	33	142	26	26	139	26	25
	Ir. Falls 115 JCT	Ir. Falls DS JCT	380	490	580	339	89	389	79	67	179	36	31	142	29	24	139	28	24
	Ir. Falls DS JCT	Ansonville TS	500	630	740	327	65	377	59	51	168	26	22	130	20	17	147	23	19
A4H	Hunta SS	Fournier JCT	260	260	260	35	13	-	-	-	185	71	71	153	59	59	102	39	39
	Fournier JCT	Ansonville TS	260	260	260	158	60	-	-	-	140	54	54	107	41	41	116	44	44
H7T	Hunta SS	Warkus JCT	500	530	530	461	92	455	85	85	465	87	87	-	-	-	412	77	77
	Warkus JCT	Timmins TS	380	380	380	338	89	332	87	87	351	92	92	-	-	-	298	78	78
H6T	Hunta SS	Tisdale JCT	500	530	530	424	84	418	78	78	-	-	-	363	68	68	377	71	71
	Tisdale JCT	Laforest Rd JCT	500	530	530	420	84	413	78	78	-	-	-	357	67	67	371	70	70
	Laforest Rd JCT	Timmins TS	380	380	380	382	100	376	99	99	-	-	-	324	85	85	338	89	89
P15T	Porcupine TS	Timmins TS	890	1140	1270	380	42	374	32	42	373	32	29	52	4	4	335	29	26
P13T	Porcupine TS	Timmins TS	890	1060	1190	373	42	368	34	41	79	7	6	318	30	26	343	32	28

Table 11a: Post-Contingency Thermal Results

Notes:

(1) G/R is required to obey the 15 minute LTR of H7T. Units rejected = NP Cochrane, TCPL Tunis, Long Sault Rapids, NP MM/Empire/Abitibi

(2) G/R is required to obey the 15 minute LTR of H6T. Units rejected = NP Cochrane, TCPL Tunis, Abitibi Canyon G2, NP MM/Empire/Abitibi

(3) G/R is required to obey the 15 minute LTR of H6T and H7T. Units rejected = NP Cochrane, TCPL Tunis, NP MM/Empire/Abitibi, Abitibi Canyon G2, NP Iroquois Falls G1

CCT	Section		LTE	STE	Loss of Ansonville T2 ⁽⁴⁾			Loss of Ansonville T2 ⁽⁵⁾			P91G H1L91 IBO ⁽⁶⁾			P91G H1L91 IBO ⁽⁷⁾		
	From	To	Amps	Amps	Amps	LTE %	STE %	Amps	LTE %	STE %	Amps	LTE %	STE %	Amps	LTE %	STE %
A5H	Hunta SS	Fournier JCT	440	440	228	52	52	26	6	6	209	47	47	37	8	8
	Fournier JCT	E. Tunis JCT	500	500	95	19	19	26	5	5	76	15	15	37	7	7
	E. Tunis JCT	Ir. Falls 115 JCT	530	540	148	28	27	36	6	6	167	31	30	43	8	7
	Ir. Falls 115 JCT	Ir. Falls DS JCT	490	580	148	30	25	36	7	6	167	34	28	43	8	7
	Ir. Falls DS JCT	Ansonville TS	630	740	137	21	18	31	4	4	156	24	21	33	5	4
A4H	Hunta SS	Fournier JCT	260	260	122	46	46	56	21	21	107	41	41	67	25	25
	Fournier JCT	Ansonville TS	260	260	9	3	3	11	4	4	17	6	6	19	7	7
H7T	Hunta SS	Warkus JCT	530	530	593	112	112	429	81	81	579	109	109	415	78	78
	Warkus JCT	Timmins TS	380	380	468	123	123	311	81	81	454	119	119	297	78	78
H6T	Hunta SS	Tisdale JCT	530	530	556	104	104	393	74	74	542	102	102	379	71	71
	Tisdale JCT	Laforest Rd JCT	530	530	552	104	104	388	73	73	538	101	101	374	70	70
	Laforest Rd JCT	Timmins TS	380	380	514	135	135	353	93	93	500	131	131	339	89	89
P15T	Porcupine TS	Timmins TS	1140	1270	511	44	40	348	30	27	497	43	39	334	29	26
P13T	Porcupine TS	Timmins TS	1060	1190	502	47	42	354	33	29	488	46	41	340	32	28

Table 11b: Post-Contingency Thermal Results

Notes:

(4) No G/R simulated.

(5) G/R is required to obey the 15 minute LTR of H6T and H7T. Units rejected = NP Cochrane, TCPL Tunis, NP MM/Empire/Abitibi

(6) G/R is required to obey the 15 minute LTR of H6T and H7T. Units rejected = NP Iroquois Falls G1, G2, G3 (as per existing SPS capability)

(7) G/R is required to obey the 15 minute LTR of H6T and H7T. Units rejected = NP Iroquois Falls G1, G2, G3, NP Cochrane, TCPL Tunis, NP MM/Empire/Abitibi

The study results show that for the loss of the Ansonville T2 autotransformer and the inadvertent breaker operation (IBO) of the 115 kV H1L91 circuit breaker at Ansonville, sufficient generation rejection resources do not exist to mitigate post contingency thermal overloads. Rejecting or the loss by configuration of the existing Northland Power Iroquois Falls generation facility will not be enough to mitigate the overloads on the H6T and H7T circuits for these contingencies. As such, it is required that Hydro One modify the existing 115 kV Northeast L/R & G/R scheme, to have various 115 kV generation facilities as selectable options for the loss of Ansonville T2 and H1L91 IBO inputs.

Post-contingency power flows through the H6T and H7T circuits will violate their respective limited time ratings for the loss of Ansonville T2 and H1L91 IBO contingencies. The incorporation of the proposed project will increase these overloading issues. Hydro One is required to modify the existing 115 kV Northeast L/R & G/R scheme to allow G/R of various 115 kV generation facilities for the selection of the Ansonville T2 and H1L91 IBO contingencies. Units selectable for G/R should include Tunis, Cochrane, Long Sault Rapids and the entire NP Solar Martin's Meadows, Abitibi and Empire facility.

6.6 Voltage Analysis

The assessment of the voltage performance in the Northeast system was done in accordance with the IESO's *Ontario Resource and Transmission Assessment Criteria*. The criteria states that with all facilities in service pre-contingency, 115 kV system voltage declines/rises following a contingency shall be limited to 10% both before and after transformer tap changer action.

The voltage study was completed with the flow levels, assumptions and generation dispatch listed in section 6.1. The constant MVA model was used in both pre-contingency state and in post-contingency post-ULTC state. The voltage dependant load model was used in post-contingency pre-ULTC state.

The study results summarized in Table 12 show no voltage performance concerns with local area 115 kV contingencies.

For contingencies to the 500 kV P502X circuit, the study results show overvoltage and voltage stability issues in the immediate post-contingency state. These issues are the result of excess vars in the post-contingency system due to capacitor banks that are left connected at Hanmer and Porcupine. A solution to this problem would be the automatic switching of capacitor banks at Porcupine and Hanmer to help mitigate overvoltage issues. This solution is consistent with conclusions and requirements made in the Lower Mattagami Generation Expansion system impact assessment (CAA ID 2006-239). Other possible solutions would include increasing the reactive absorbing capability of the Porcupine SVC.

Monitored Busses		Pre-Cont Voltage (kV)	<i>Loss of NP A5H Solar Farm</i>				<i>Loss of A5H</i>				<i>Loss of P13T</i>				<i>Loss of P15T</i>			
Bus Name	Base (kV)		Pre-ULTC		Post-ULTC		Pre-ULTC		Post-ULTC		Pre-ULTC		Post-ULTC		Pre-ULTC		Post-ULTC	
			kV	%	kV	%	kV	%	kV	%	kV	%	kV	%	kV	%	kV	%
Porcupine TS	118	126.4	127.1	0.6	127.1	0.6	127.7	1	127.7	1	127.3	0.7	127.4	0.8	127.6	1	127.6	1
Timmins K1	118	125.7	126.4	0.6	126.1	0.3	127.0	1	127.0	1	126.7	0.8	126.7	0.8	126.4	0.6	126.4	0.6
Timmins K2/K3	118	125.9	126.6	0.6	126.6	0.6	127.3	1.1	127.3	1.1	126.3	0.3	126.3	0.3	125.1	-0.6	124.9	-0.8
Hunta SS	118	127.7	128.1	0.3	128.1	0.3	128.7	0.8	128.7	0.8	127.7	0	127.9	0	127.7	0	127.7	0
Canyon SS	118	129.2	129.3	0.1	129.3	0.1	129.7	0.4	129.7	0.4	129.1	-0.1	129.1	-0.1	129.1	-0.1	129.1	-0.1
Ansonville SS	118	123.6	123.9	0.3	123.9	0.3	122.3	-1.1	122.3	-1.1	122.6	-0.8	122.6	-0.8	122.8	-0.6	122.8	-0.6
NP SF A5H	118	127.1	127.6	0.4	127.6	0.4	127.1	0	127.1	0	126.9	-0.2	126.9	-0.2	126.9	-0.1	126.9	-0.1

Monitored Busses		Pre-Cont Voltage (kV)	<i>Loss of P502X⁽¹⁾</i>				<i>Loss of P502X⁽²⁾</i>			
Bus Name	Base (kV)		Pre-ULTC		Post-ULTC		Pre-ULTC		Post-ULTC	
			kV	%	kV	%	kV	%	kV	%
Pinard TS	500	526.5	-	-	-	-	-	-	-	-
Porcupine TS	500	525.9	562.1	6.9	Diverged	N/A	528.7	0.5	529.2	0.6
Hanmer TS	500	537.7	558.3	3.8	Diverged	N/A	548.4	2	550.7	2.4
Pinard TS	220	238	-	-	-	-	-	-	-	-
Porcupine TS	220	242.9	259.2	6.7	Diverged	N/A	242.9	0	242.9	0
Hanmer TS	220	243.2	250.3	2.9	Diverged	N/A	243.9	0.3	245.4	0.9
Ansonville SS	220	239.2	258.1	7.9	Diverged	N/A	244.7	2.3	244.8	2.3
Porcupine TS	118	126.4	137	8.4	Diverged	N/A	129.5	2.5	129.8	2.7
Timmins K1	118	125.7	136.4	8.5	Diverged	N/A	129.1	2.7	129.3	2.8
Timmins K2/K3	118	125.9	136.6	8.5	Diverged	N/A	129.3	2.7	129.7	3
Hunta SS	118	127.7	133.8	4.8	Diverged	N/A	129.2	1.1	129.5	1.4
Canyon SS	118	129.1	134.3	4	Diverged	N/A	130.1	0.8	130.5	1.1
Ansonville SS	118	123.6	130.3	5.4	Diverged	N/A	126	1.9	126.2	2.1
NP SF A5H	118	127.1	132.7	4.4	Diverged	N/A	128.2	0.8	128.5	1.1

Table 12: Voltage Study Results

Notes:

(1) Post-Contingency Flow on A9K + A8K = 16 MW South
 Cross tripping of circuits D501P, L21S and K38S
 Total G/R = 1460 MW

(2) Post-Contingency Flow on A9K + A8K = 35 MW South
 Cross tripping of circuits D501P, L21S and K38S
 Total G/R = 1460 MW
 Automatic Capacitor Switching = 2 x Porc. + 1 x Hanmer

Post-contingency voltage stability and overvoltage issues exist with the loss of the 500 kV P502X circuit without the rejection of new and existing capacitor banks at Hanmer TS and Porcupine TS. Automatic switching of these capacitors, as well as newly installed capacitors at Pinard TS will need to be implemented to mitigate overvoltage concerns in the Northeast system. This switching can be implemented using a voltage based switching scheme on the condition that voltage thresholds are suitably chosen and time delays are minimal. Should Hydro One be unable to meet these conditions, the automatic switching of these capacitors will need to be added as responses to various contingencies to the existing Moose River G/R and/or Northeast 115 kV L/R & G/R schemes.

No other voltage concerns were identified with the incorporation of the proposed project.

6.7 Transient Analysis

Transient stability analyses were performed considering faults in the Northeast system with the Northland Power Martin's Meadows, Abitibi and Empire facilities in-service. Various three phase and LLG faults were considered under the study conditions outlined in Section 6.1.

ID	Contingency	Location	Fault MVA	Fault Clearing Time (ms)		G/R Scheme (ms)		Circuit Cross Tripping (ms)	
				Local	Remote	Moose River	NE 115 kV	L21S/K38S	D501P
TC1	X503E	Hanmer	3 Phase	66	91	-	-	-	-
TC2	P502X ⁽¹⁾	Hanmer	3 Phase	66	91	180	230	180	@P=91ms, @D=120 ms
TC3	H7T	Hunta	520 – j2150	83	111	-	230	-	-
TC4	H6T	Hunta	520 – j2150	83	111	-	230	-	-
TC5	P13T	Timmins	460 – j3300	83	349 ⁽²⁾	-	-	-	-
TC6	P15T	Timmins	460 – j3300	83	349 ⁽²⁾	-	-	-	-
TC7	P13T	Porcupine	420 – j7200	83	349 ⁽²⁾	-	-	-	-
TC8	P15T	Porcupine	420 – j7200	83	349 ⁽²⁾	-	-	-	-

Table 13: Transient Simulation Information

Notes:

(1) Capacitors at Porcupine 230 kV and Hanmer 230 kV were tripped 1 second after the fault

(2) Long remote end fault clearing time is due to the use of Remote Trip communication signals on the P13T and P15T circuits instead of normally used Transfer Trip communication signals. The use of single channel remote trip signals through DC metallic leased wires results in a communication delay of 270 ms

Transient simulations for the P13T @ Porcupine contingency resulted in the transient instability of the Lower Sturgeon generators. Due to the small size of these embedded units and the fact their instability does not propagate to the rest of the system, this does not pose any reliability concerns to the IESO controlled grid. Plots of all local generator angles during this fault are shown in Figure 11. Lower Sturgeon units are tripped when their rotor angles reach approximately 360 degrees to simulate their generator out-of-step protections. All other units remain stable and show well-damped angle oscillations.

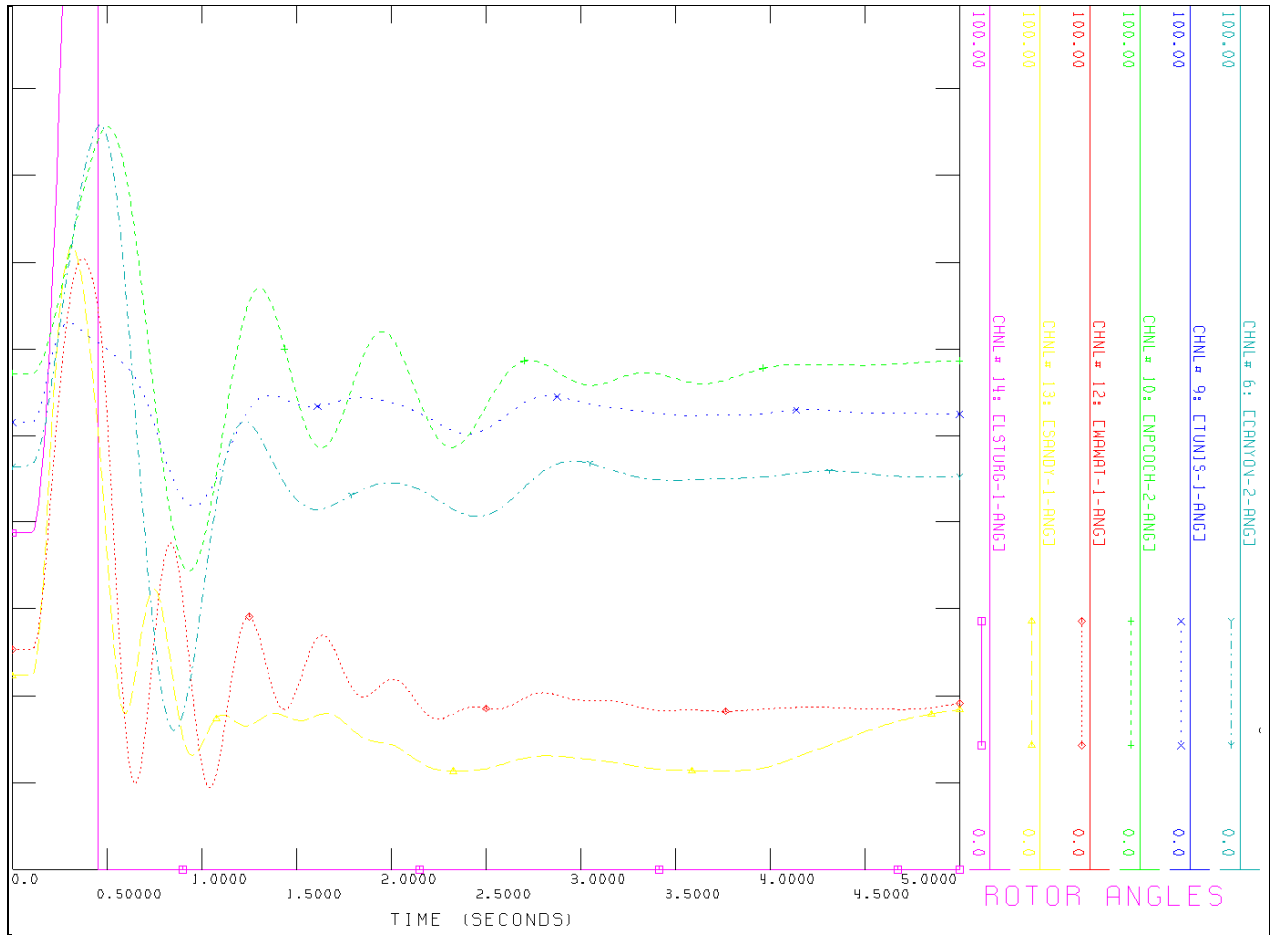

Figure 11: Local Area Generator Angles for P13T @ Porcupine L-L-G Fault

Appendix A shows the plots of all other simulated transient contingencies, which show no transient performance issues. It can be concluded from the results that, with Northland Power Abitibi, Martin’s Meadows and Empire on-line, none of the simulated contingencies result in transient performance concerns.

L-L-G faults at Porcupine on the P13T circuit result in transient instability of the Lower Sturgeon embedded generators, but do not pose any reliability concerns to the IESO controlled grid. The incorporation of the proposed facility will contribute to this existing issue. It is recommended that Hydro One upgrade teleprotections for the P13T and P15T circuits to reduce remote end fault clearing times for faults on these circuits.

All other transient contingencies show stable and well damped oscillations with the incorporation of the proposed project.

6.8 Relay Margin

It is necessary that sufficient margin is maintained between the impedance characteristics of the relays at the terminals of un-faulted circuits and the apparent impedance trajectories during external faults. This is required to ensure that protective relaying does not inadvertently trip for any external faults.

The IESO requires that the relay margin following fault clearance for 115 kV circuits to be a minimum of 15 percent on all instantaneous relays and zero percent on all timed relays having time delays less than or equal to 0.4 seconds. For relays with time delay settings greater than 0.4 seconds, the apparent impedance trajectory may enter the tripping characteristic after fault clearance for a period of time no greater than one-half of the relay time delay setting.

The following are the time delay settings of all relays used in the analysis:

Circuit	Terminal	Protection	Time Delay (seconds)
D3K	Dymond	A21	Zone 1 = 0 Zone 2 = 0.4
	Kirkland Lake	A21	Zone 1 = 0 Zone 2 = 0.65
	Kirkland Lake	B21	Zone 1 = 0 Zone 2 = 0.65

Note:

'B' Protections at the Dymond terminal have no zone 2 coverage, thus, no relay margin analysis has been completed for those protections

Figures 12 and 13 show the relay characteristics and the apparent impedance trajectory of 115 kV circuit D3K for a 3 phase fault at Hanmer on P502X.

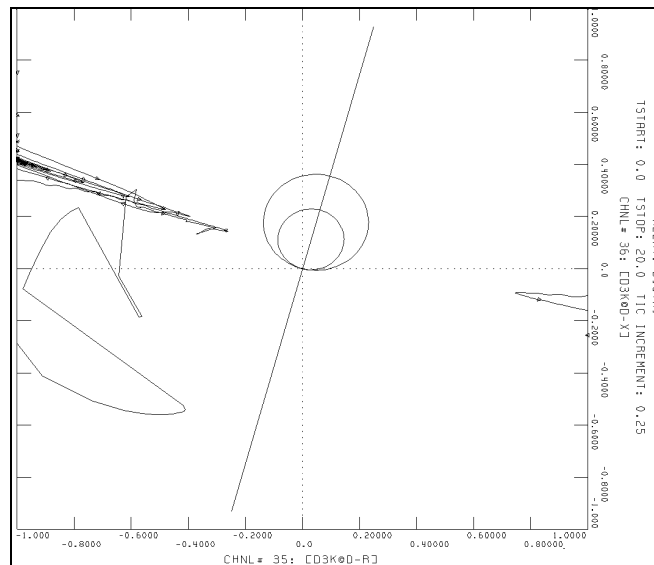

Figure 12: D3K @ Dymond 'A' protections for 3 phase fault at Hanmer on P502X

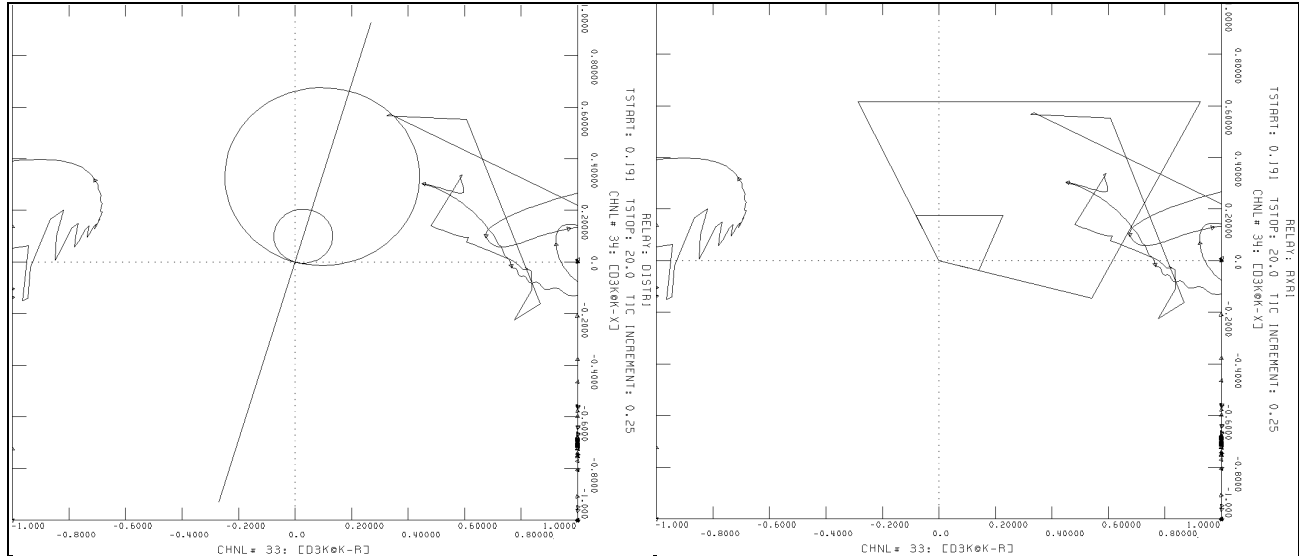

Figure 13: D3K @ Kirkland Lake ‘A’ & ‘B’ protections for 3 phase fault at Hanmer on P502X

It can be seen that the trajectory for the Kirkland Lake terminal of D3K enters the ‘A’ and ‘B’ protections, zone 2 characteristics. While ‘A’ protections incursions were minimal, ‘B’ protections incursions would enter the zone 2 characteristic for approximately 350 ms, resulting in the violations of the IESO relay margin criteria. This result is consistent with conclusions and requirements made in various system impact studies completed for the incorporation of Nobel SS (CAA ID 2004-160), Lower Mattagami Expansion (CAA ID 2006-239), Porcupine and Kirkland Lake SVC (CAA ID 2006-223).

Relay margin violations exist at the Kirkland Lake terminal of the D3K circuit for a 3 phase fault on the P502X circuit at Hanmer. Hydro One is required to continue work on resolving these relay margin violations. Possible solutions include revising ‘B’ protection settings to reduce the Zone 2 quad characteristic.

6.9 Low-Voltage Ride Through Capability

The new generating facility is required to ride through routine switching events and design criteria contingencies assuming standard fault detection, auxiliary relaying, communication, and rated breaker interrupting times, unless disconnected by configuration.

Large shunt reactive elements are common at transmission stations in Ontario. The magnitude of routine switching transients is site dependent and must be considered in equipment design. Please be aware that in the electrical proximity of the facility there are the following switching elements:

- +300/-100 MVar SVC at Porcupine 230 kV
- +200/-100 MVar SVC at Kirkland Lake 115 kV
- Shunt Capacitor Banks at Porcupine 230 kV bus (2 x 100 MVar @ 250 kV)
- 500 kV circuits P502X and D501P

As with any other generator, the SC500 is expected to trip only for contingencies which remove the generator by configuration or abnormal conditions such as severe and sustained under-voltage, over-voltage, under-frequency, over-frequency etc. The severity of under-voltage seen by generator terminals is to be temporarily mitigated by the LVRT capability. The LVRT feature is implemented by injection of

additional reactive current by the grid side AC/DC converter to maintain generator terminal voltage in the event of a disturbance in the power system that causes the terminal voltage to drop. The implementation of LVRT should not require any instant modification to under-voltage protection settings. In the PSS/E model for the SC500 inverter, the LVRT feature accompanies a change of under-voltage/overvoltage settings as shown below.

<i>Voltage range</i>	<i>Event</i>
$V > 1.20 \text{ pu}$	Trips in 0.16 sec
$1.20 > V > 1.10 \text{ pu}$	Trips in 1.00 sec
$1.10 > V > 0.85 \text{ pu}$	No trip
$0.85 > V > 0.45 \text{ pu}$	Trips in 2.00 sec
$0.45 > V > 0.00 \text{ pu}$	Trips in 0.16 sec

In order to examine the need for low voltage ride through (LVRT) capability, the terminal voltages of the PV inverters was monitored for the contingencies outlined in Table 13 of Section 6.7. The variation of the terminal voltage of the new generation facility is plotted in Figure 14. It can be seen that the duration during which the PV inverter terminal voltage drops below 0.85 pu is about 0.1 sec and that the terminal voltage never drops below 0.45 pu. Therefore, fault ride through capability of the proposed inverters is adequate.

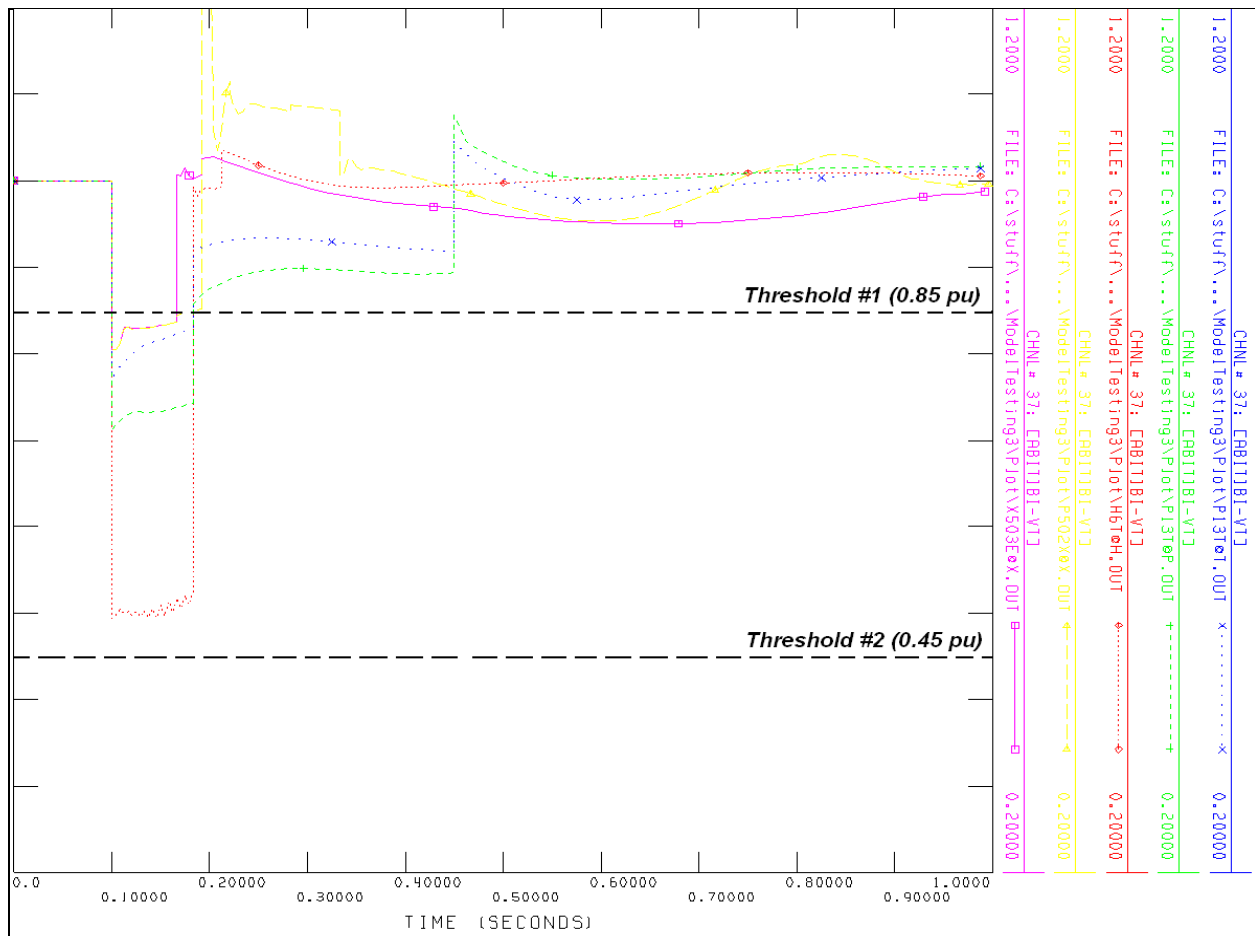

Figure 14: Terminal Voltage of SC500 Inverter During Various Simulated Faults

The LVRT capability must be demonstrated during commissioning by monitoring several variables under a set of IESO specified field tests and the results should be verifiable using the PSS/E model.

6.10 Special Protection System (SPS)

The Northeast 115 kV Load and Generation Rejection Scheme was designed to address the problem of excess generation being imposed on the underlying 115 kV system under contingency conditions involving the 500 kV, 230 kV and 115 kV Systems north of Sudbury.

Due to the MW capacity of the Northland Power Abitibi, Martin’s Meadow and Empire project and its location in the Northeast power system, the proposed project must be added to the NE 115 kV L/R & G/R Scheme to help address post-contingency thermal overloading of the H6T and H7T circuits, as well as to help respect existing post-contingency operating limits at Ansonville TS. The G/R for the facility must be initiated upon the detection of the P502X, P91G, A4H, H6T, H7T, H6T & H7T, H1L91 IBO and Ansonville T2 contingencies. G/R can be initiated by tripping the total 30 MW facility via the 115 kV breaker located at the project’s connection point to the IESO controlled grid.

North East 115 kV L/R & G/R Scheme								
OUTPUT: CONTROL ACTIONS	INPUT: CONTINGENCY SIGNALS							
	P502X	P91G	A4H	H6T	H7T	H6T & H7T	new: P91G H1L91 IBO	new: Ansonville T2
new: Martin’s Meadows, Empire, Abitibi	X	X	X	X	X	X	X	X
Long Sault Rapids NUG	X	X	X	X	X	X	X	X
Cochrane Power NUG	X	X	X	X	X	X	X	X
Tunis NUG	X	X	X	X	X	X	X	X

- Existing
 - New

Figure 15: Modifications to the NE 115 kV L/R & G/R Scheme

Similar to existing generation facilities connected in the Northeast system, the proposed project must participate in the North East 115 kV L/R & G/R Special Protection Scheme to address post-contingency thermal overloading of the H6T and H7T circuits, as well as to respect existing post-contingency operating limits at Ansonville TS. The facility must be able to be selected for G/R upon the detection of the P502X, P91G, A4H, H6T, H7T, H6T & H7T, H1L91 IBO and Ansonville T2 contingencies. The Northeast 115 kV L/R & G/R scheme is expected to maintain its Type III Special Protection Scheme classification after the proposed modifications.

– End of Report –

Appendix A: Diagrams for Transient Simulation Results

TC1 – X503E @ Hanmer:

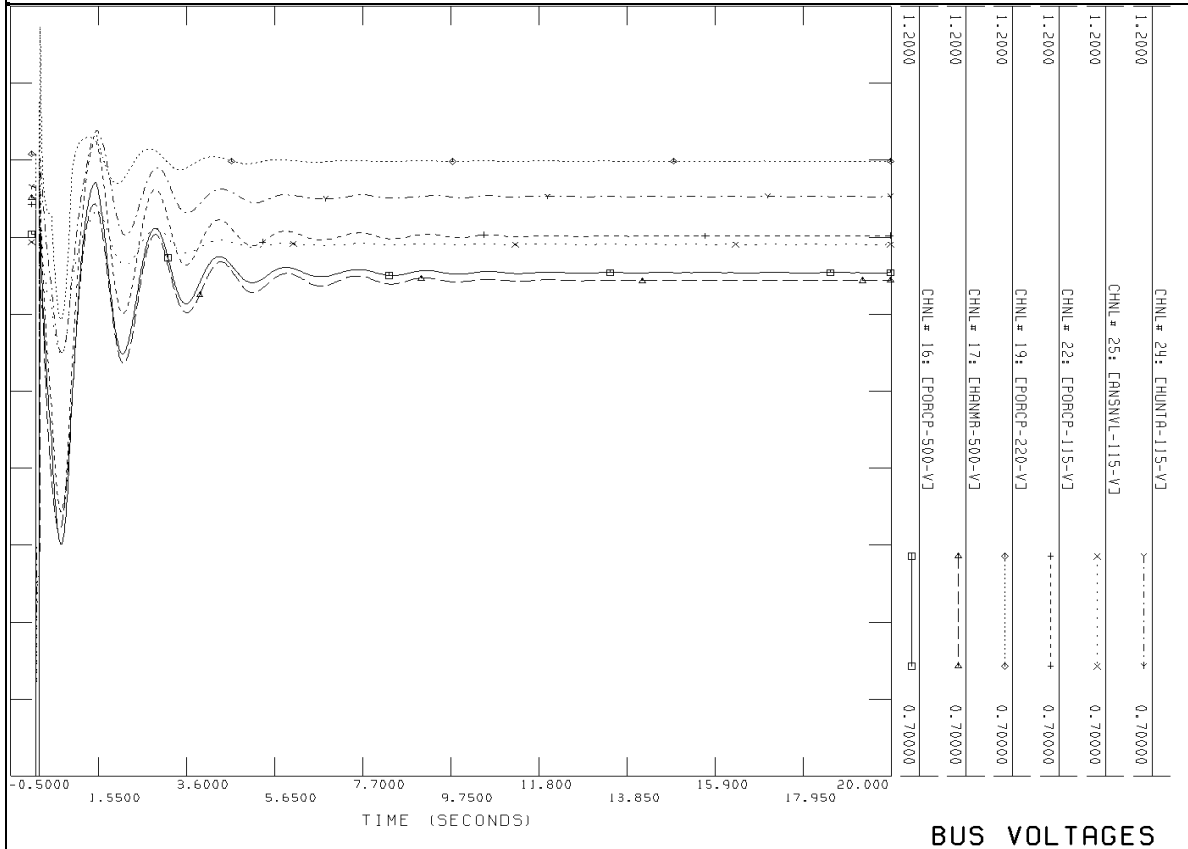
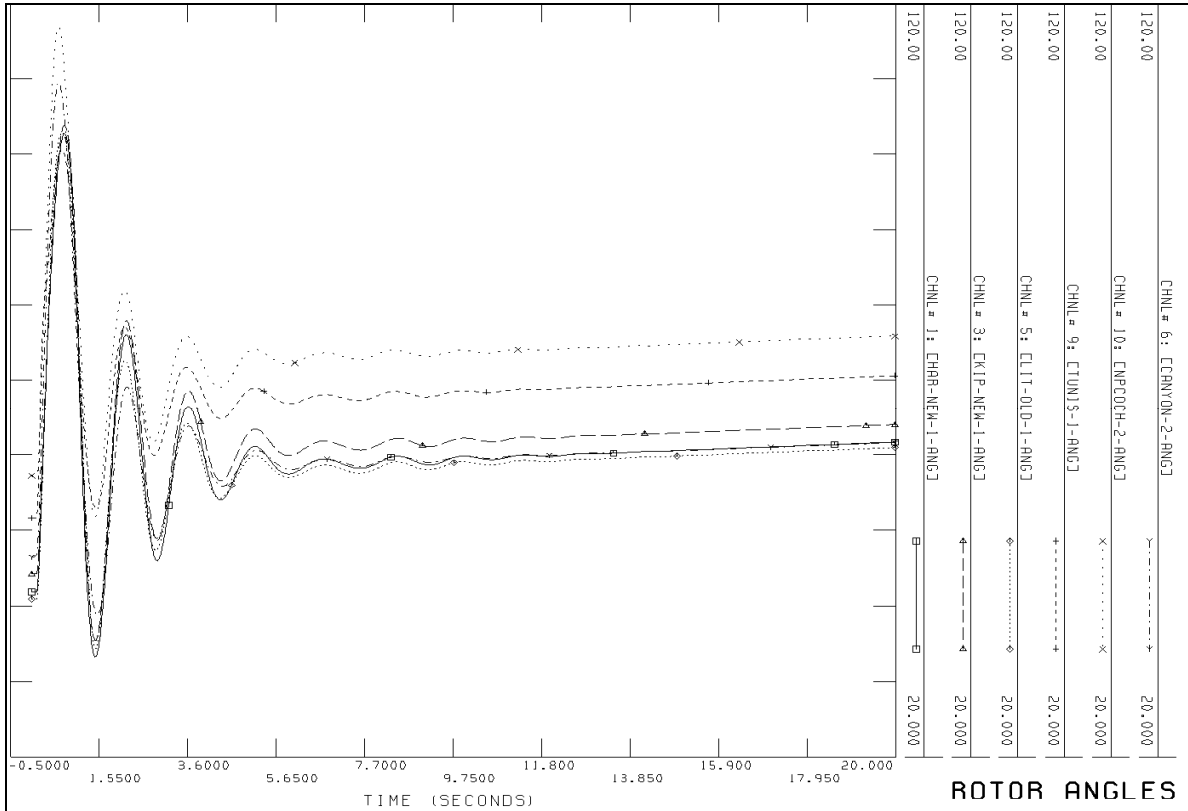

TC2 – P502X @ Hanmer:

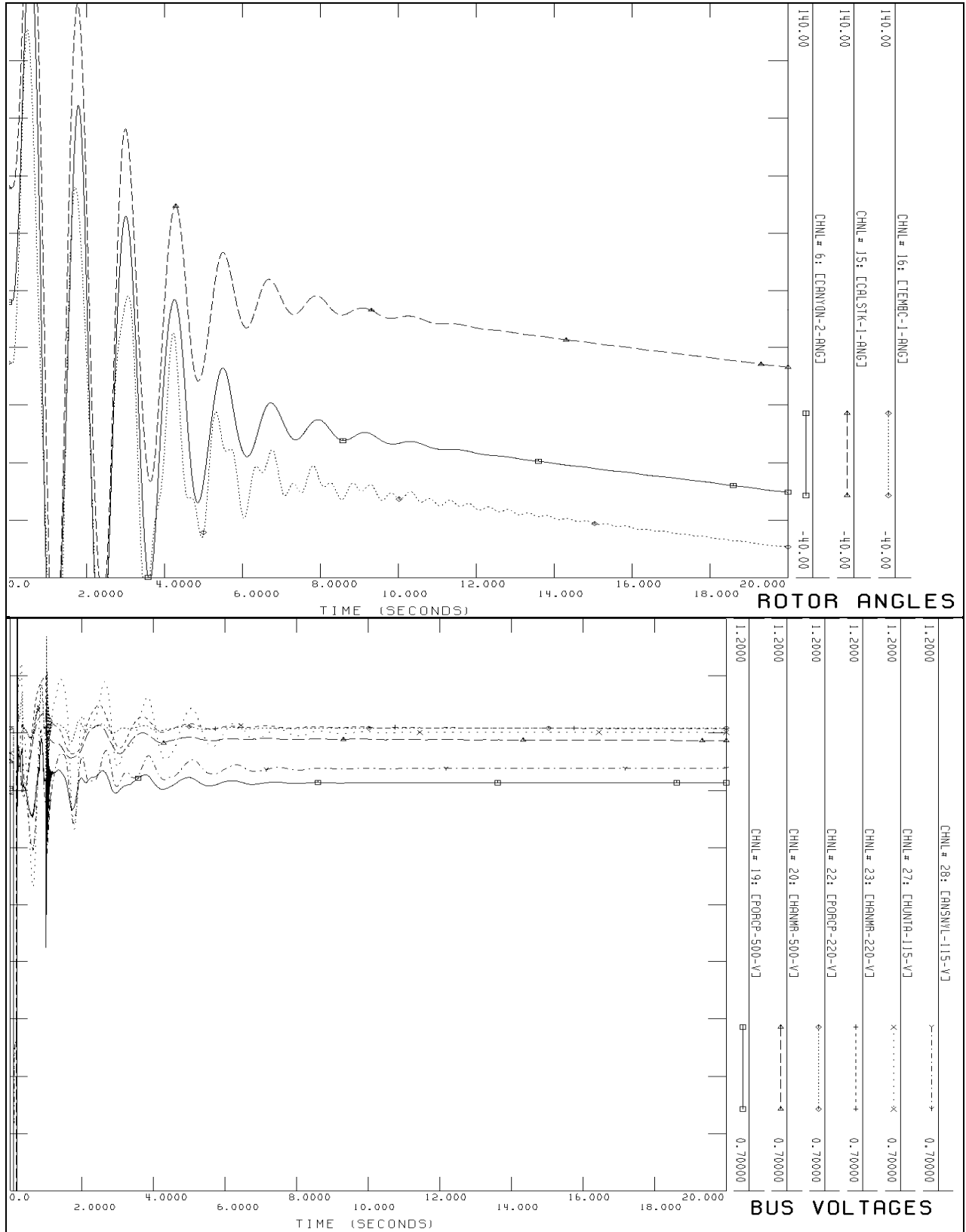

TC3 – H7T @ Hunta:

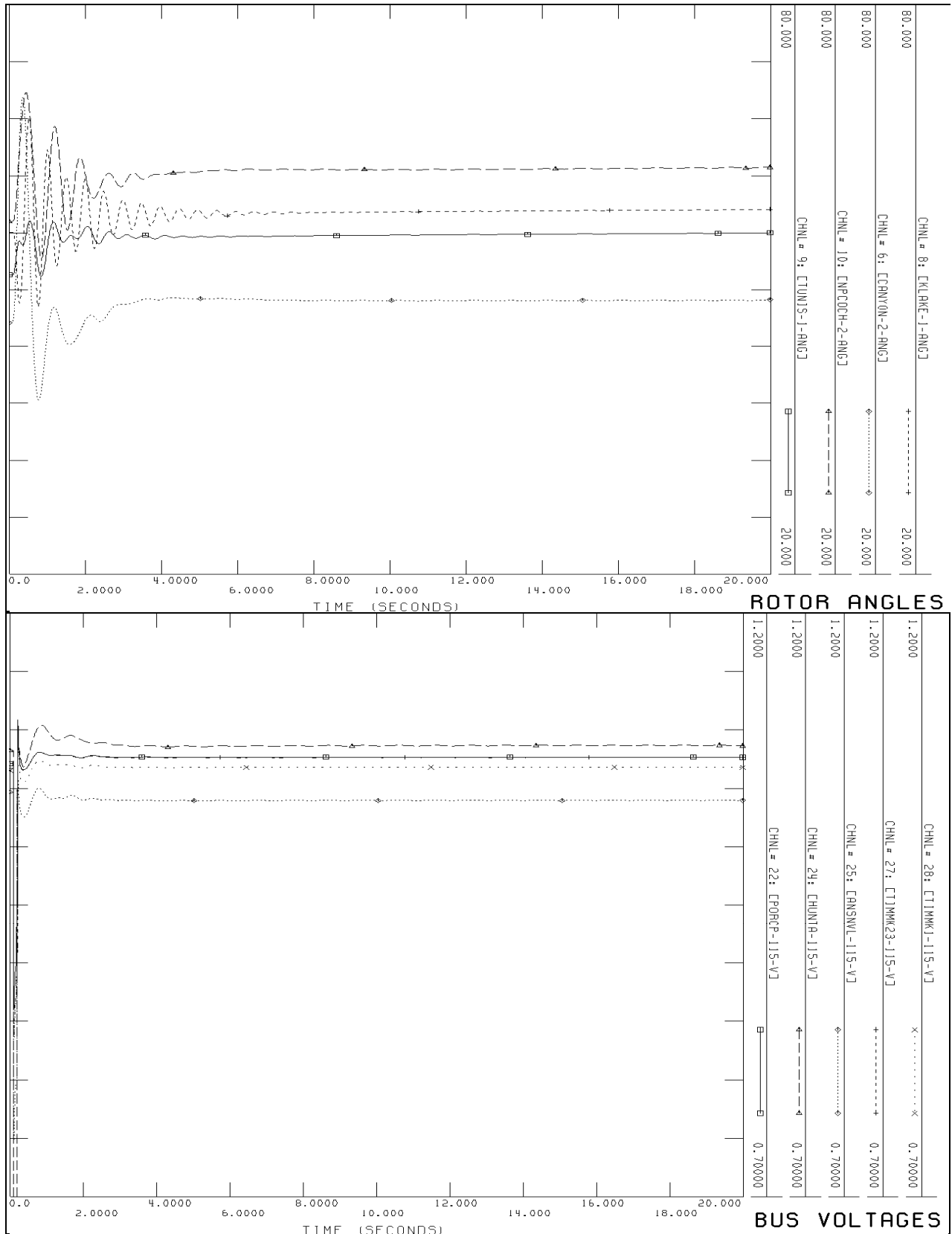

TC4 – H6T @ Hunta:

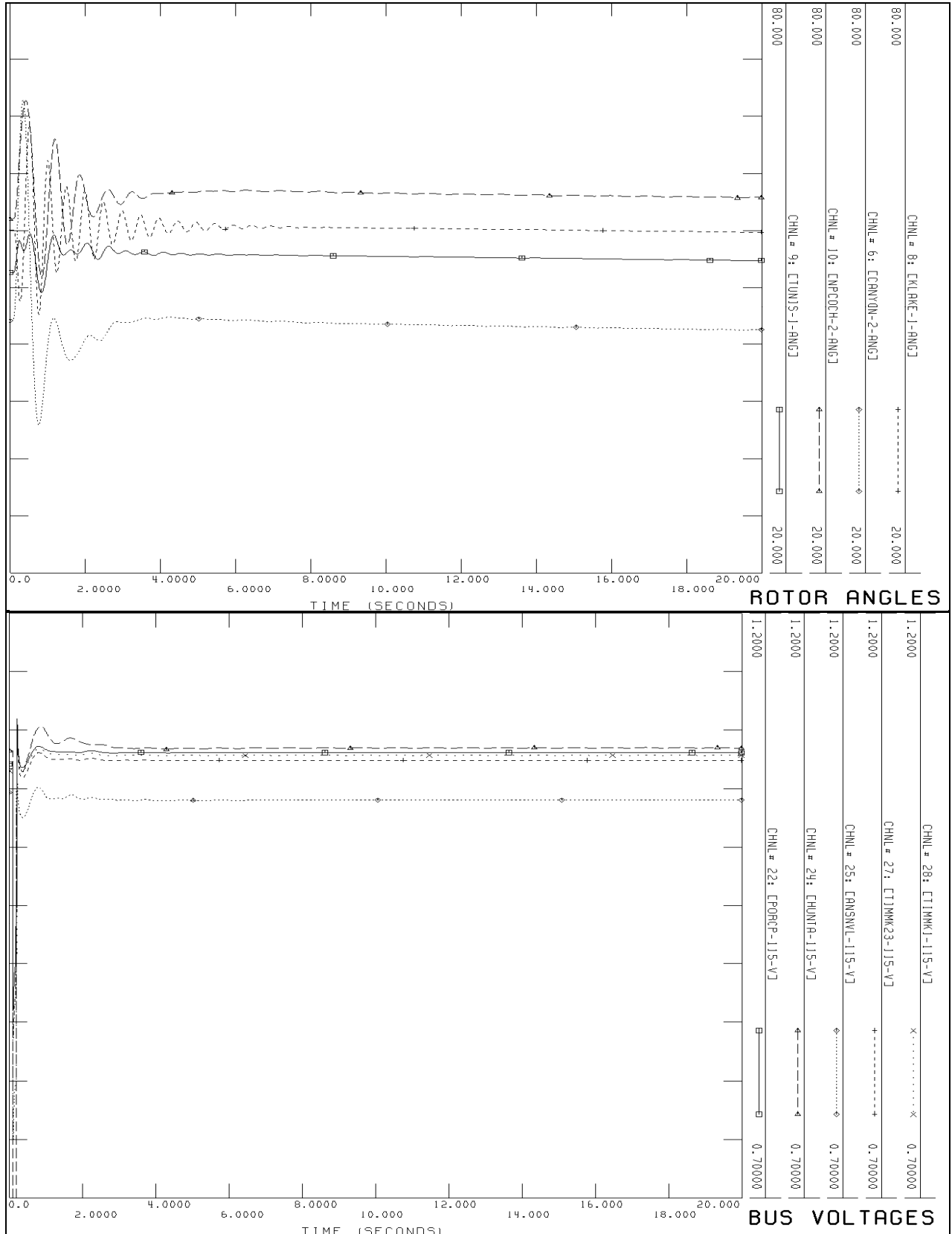

TC5 – P13T @ Timmins:

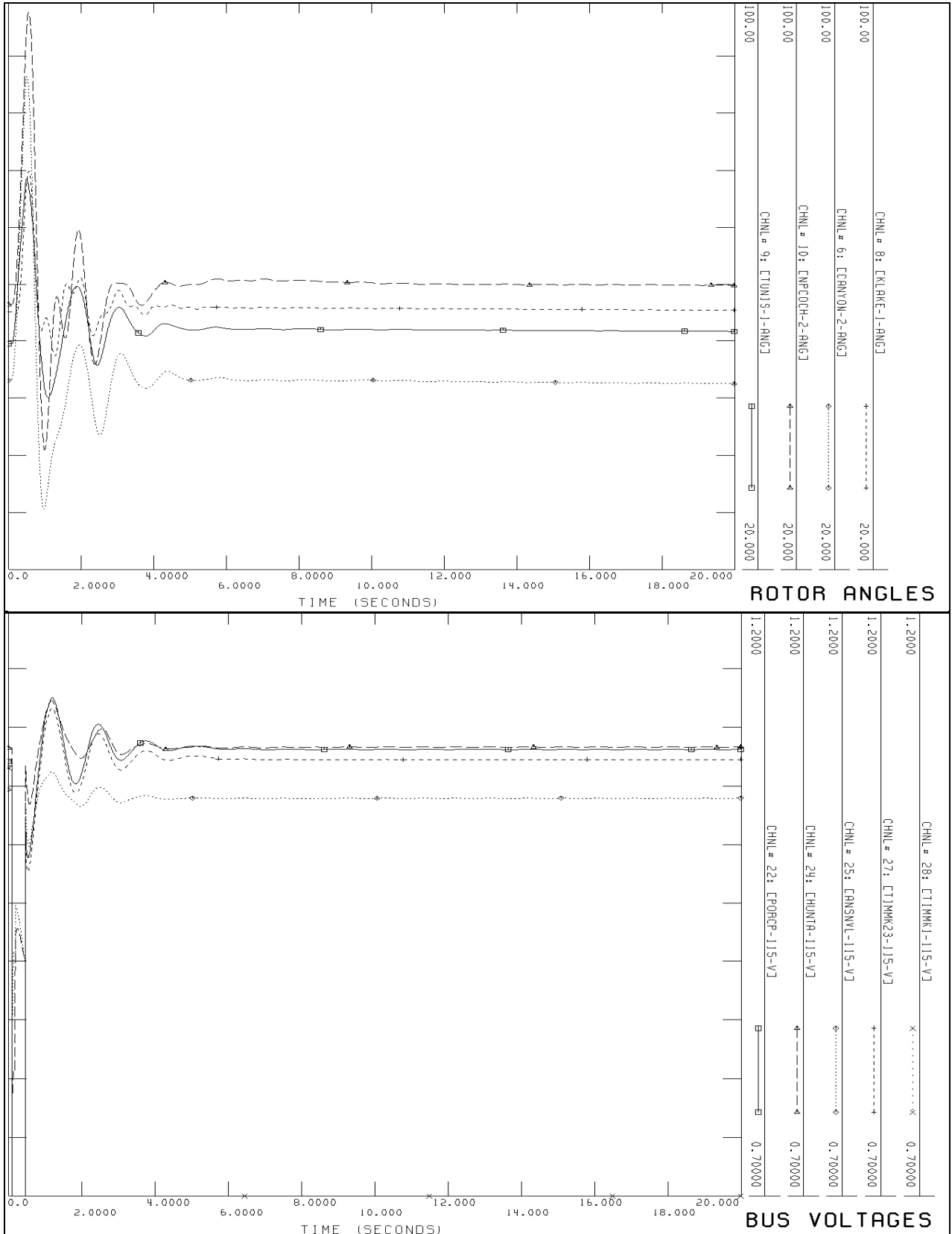

TC6 – P15T @ Timmins:

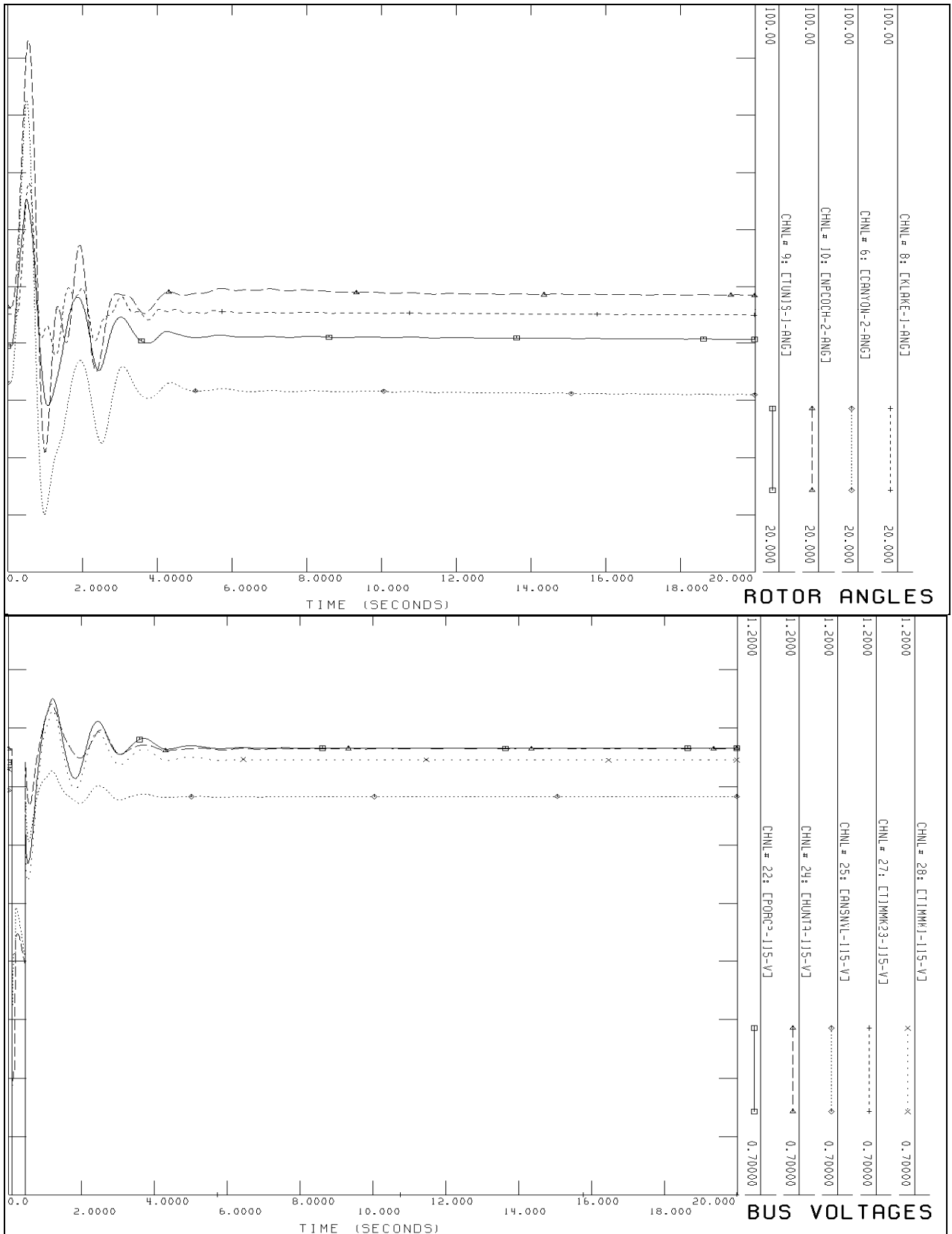

TC7 – P13T @ Porcupine:

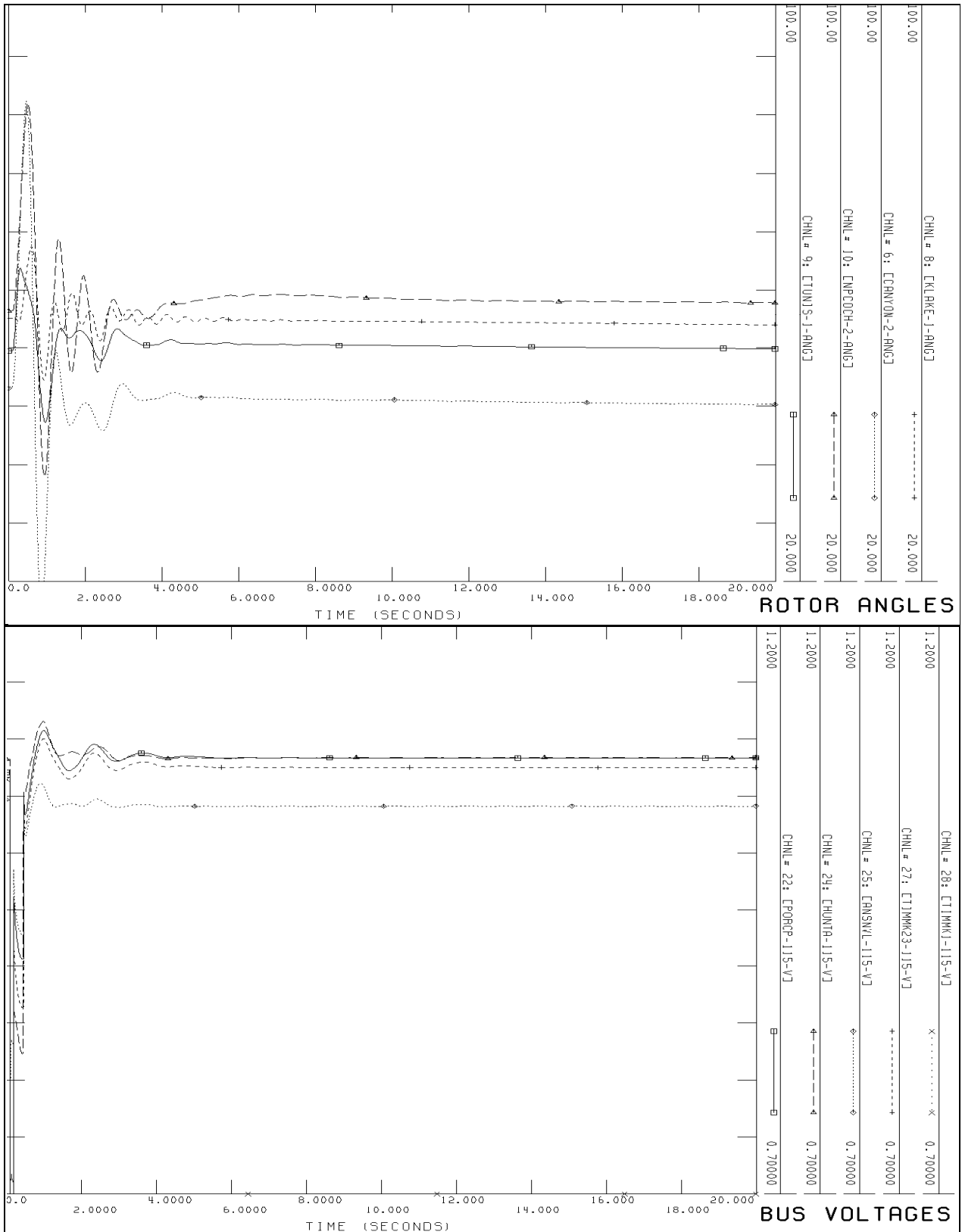

TC8 – P15T @ Porcupine:

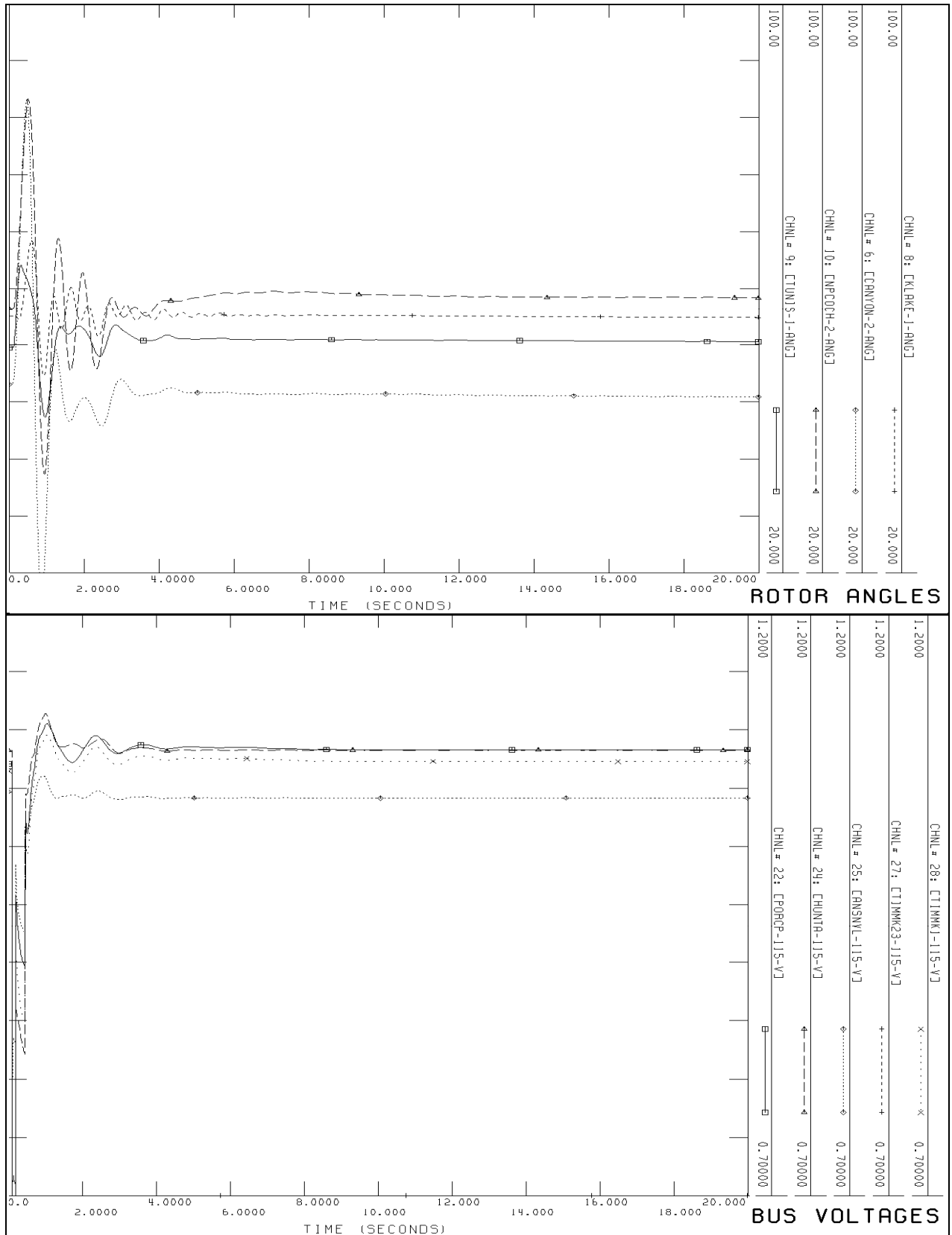

Appendix B: Protection Impact Assessment

Hydro One Networks Inc.
483 Bay Street
Toronto, Ontario
M5G 2P5



PROTECTION IMPACT ASSESSMENT

NORTHLAND SOLAR GENERATORS ON A5H PROJECT

3x10 MVA SOLAR GENERATORS
GENERATION CONNECTION

Date: September 24, 2010
P&C Planning Group Project #: PCT-016-PIA

Prepared by
Hydro One Networks Inc.

COPYRIGHT © HYDRO ONE NETWORKS INC. ALL RIGHTS RESERVED

Disclaimer

This Protection Impact Assessment has been prepared solely for the IESO for the purpose of assisting the IESO in preparing the System Impact Assessment for the proposed connection of the proposed generation facility to the IESO-controlled grid. This report has not been prepared for any other purpose and should not be used or relied upon by any person, including the connection applicant, for any other purpose.

This Protection Impact Assessment was prepared based on information provided to the IESO and Hydro One by the connection applicant in the application to request a connection assessment at the time the assessment was carried out. It is intended to highlight significant impacts, if any, to affected transmission protections early in the project development process. The results of this Protection Impact Assessment are also subject to change to accommodate the requirements of the IESO and other regulatory or legal requirements. In addition, further issues or concerns may be identified by Hydro One during the detailed design phase that may require changes to equipment characteristics and/or configuration to ensure compliance with the Transmission System Code legal requirements, and any applicable reliability standards, or to accommodate any changes to the IESO-controlled grid that may have occurred in the meantime.

Hydro One shall not be liable to any third party, including the connection applicant, which uses the results of the Protection Impact Assessment under any circumstances, whether any of the said liability, loss or damages arises in contract, tort or otherwise.

EXECUTIVE SUMMARY

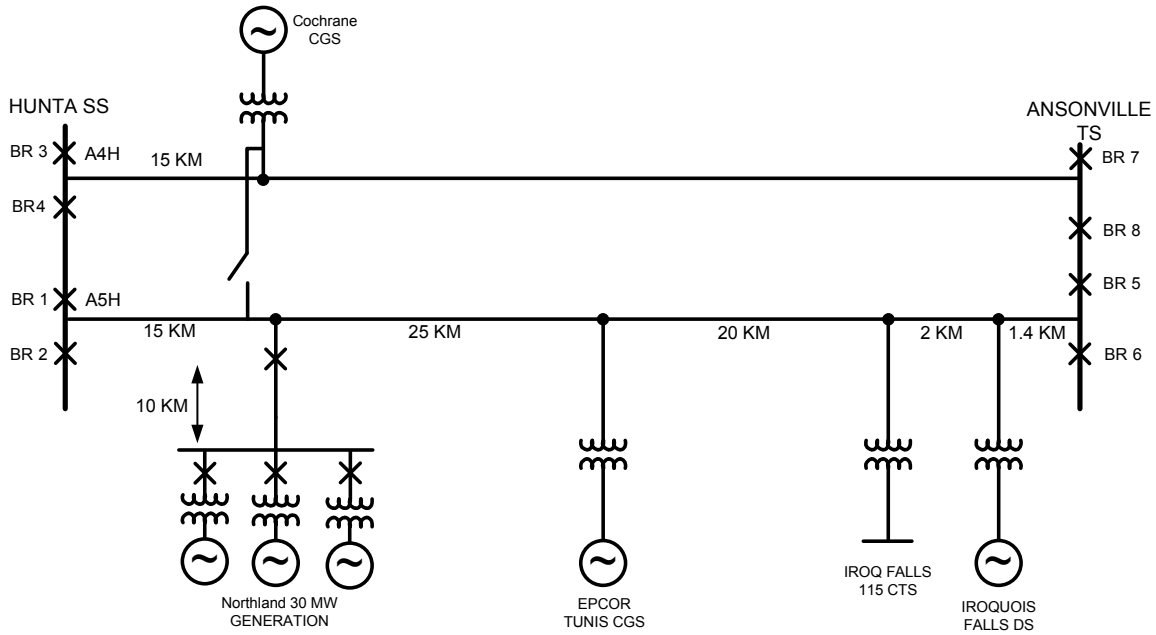

Figure 1: 30 MVA Solar Generation Connection to HONI Transmission System

It is feasible for Northland Solar Farm to connect the proposed 30 MW generation at the location in Figure 1 as long as the proposed changes are made:

PROTECTION HARDWARE

The present distance relays will need to be upgraded to standard IEDs.

The present protections on A5H will continue to function with the existing teleprotection scheme for the Hunta and Ansonville terminals. Protection scheme will have to be modified and hardware addition is required for a blocking signal from the new Northland Solar generator to be incorporated into the existing scheme.

PROTECTION SETTING

Two setting groups will be required for when (1) Cochrane is on A4H and (2) Cochrane is on A5H. The existing Zone 2 reach will be adjusted to cover the maximum apparent impedance due to the connection of the Northland Solar Farm, for both setting groups.

TELECOMMUNICATIONS

New telecommunication link(s) need to be established to transmit protection signals among all stations that are required for the reliable fault clearing. The provision of new telecommunication facilities that are required to facilitate this connection (subject to final design considerations) is responsibility of the proponent.