

---

**NORTHGATE MINERALS CORPORATION**  
**SYSTEM IMPACT ASSESSMENT**  
**FOR**  
**YOUNG-DAVIDSON PROJECT**

Report No.: RP-158985-00-141-0001  
CAA ID No. 2008-312

Rev. 02

Prepared by:



AMEC Americas Limited  
Energy and Mining Division  
Power & Process Group  
Suite 700, 2020 Winston Park Drive  
Oakville, ON L6H 6X7

August 2009

---





**REVISION HISTORY**

Rev.	Description	Prepared By	Checked By	Approved By	Date
00	Original	MME	BJN	DW	05/12/2009
01	Revised base case	MME	BJN	DW	07/20/2009
02	Changes to text and SVC size	MME	BJN	DW	2009/AUG/07

This report was prepared exclusively for Northgate Minerals Corporation and the Independent Electricity System Operator (IESO), by AMEC Americas Limited, a wholly owned subsidiary of AMEC Inc. The quality of information, conclusions and estimates contained herein is consistent with the level of effort involved in AMEC services and based on:

1. information available at the time of preparation,
2. data supplied by outside sources, and
3. the assumptions, conditions and qualifications set forth in this report.

This report is intended to be used by Northgate Minerals Corporation and the IESO, subject to the terms and conditions of the contract with AMEC. Other use of, or reliance on, this report by a third party is at that party's sole risk.

## TABLE OF CONTENTS

<b>1.0</b>	<b>SUMMARY .....</b>	<b>1</b>
<b>2.0</b>	<b>INTRODUCTION .....</b>	<b>2</b>
<b>3.0</b>	<b>EXISTING SYSTEM .....</b>	<b>3</b>
<b>3.1</b>	<b>BASE CASE CONFIGURATION .....</b>	<b>3</b>
<b>4.0</b>	<b>PROPOSED SYSTEM .....</b>	<b>4</b>
<b>4.1</b>	<b>DESCRIPTION OF YOUNG-DAVIDSON .....</b>	<b>4</b>
<b>4.2</b>	<b>SYSTEM MODELLING SETTINGS .....</b>	<b>5</b>
4.2.1	AG Mill Load .....	5
4.2.2	Young-Davidson VAR Support .....	5
4.2.3	Other .....	5
<b>5.0</b>	<b>SYSTEM STUDY PARAMETERS .....</b>	<b>6</b>
<b>5.1</b>	<b>DESCRIPTION OF TEST CASES .....</b>	<b>6</b>
<b>5.2</b>	<b>SYSTEM CONSTRAINTS .....</b>	<b>8</b>
<b>6.0</b>	<b>IMPACT ON THE IESO-CONTROLLED GRID .....</b>	<b>9</b>
<b>6.1</b>	<b>SHORT CIRCUIT ASSESSMENT .....</b>	<b>9</b>
<b>6.2</b>	<b>THERMAL ANALYSIS .....</b>	<b>9</b>
<b>6.3</b>	<b>STEADY STATE VOLTAGE ANALYSIS .....</b>	<b>10</b>
<b>6.4</b>	<b>STEADY STATE MOTOR STARTING ANALYSIS .....</b>	<b>11</b>
<b>6.5</b>	<b>TRANSIENT VOLTAGE ANALYSIS .....</b>	<b>11</b>
6.5.1	Motor Starting .....	11
6.5.2	Line-to-Line-to-Ground (LLG) Fault .....	12
6.5.3	Dynamic SVC Requirements .....	12
<b>6.6</b>	<b>SUMMARY OF YD SVC REQUIREMENTS .....</b>	<b>13</b>
<b>6.7</b>	<b>ADDITIONAL TESTS WITH YD REACTIVE COMPENSATION SYSTEM .....</b>	<b>14</b>
<b>6.8</b>	<b>LIMIT TESTS WITH YD REACTIVE COMPENSATION SYSTEM .....</b>	<b>14</b>
<b>7.0</b>	<b>CONCLUSIONS .....</b>	<b>16</b>

## LIST OF TABLES

Table 4.1: New K4 Conductor Impedance.....	4
Table 5.1: Summary of Test Cases.....	6
Table 5.2: ORTAC Acceptable System Voltages .....	8
Table 6.1: YD Short Circuit Contribution Assessment Results .....	9
Table 6.2: Summary of Thermal Analysis.....	9
Table 6.3: Summary of Line Losses.....	10
Table 6.4: Load Distribution Factors .....	10
Table 6.5: Steady State Voltage Analysis YD SVC Requirement .....	11
Table 6.6: Transient Study YD SVC Requirement.....	13
Table 6.7: Limit Tests - SVC and Capacitor Output.....	14

## LIST OF APPENDICES

<b>APPENDIX A: FIGURES.....</b>	<b>19</b>
Appendix A1: One Line Diagram of the Northeastern Ontario Area	
Appendix A2: One Line Diagram of the Dymond Load Area (DAL)	
Appendix A3: 115 kV Circuits K2 and K4 Historical Loads from July 7, 2007 to July 7, 2008	
Appendix A4: Voltage Starting Characteristics for the AG Mill	
Appendix A5: Calculated Open and Short Circuit Saturation Curves for AG Mill	
Appendix A6: One Line Diagram of the Young-Davidson Project	
<b>APPENDIX B: PSS/E MODELLING DATA.....</b>	<b>29</b>
Appendix B1: CIM5BL Induction Motor Load Model	
Appendix B2: GENROU Round Rotor Generator Model (Quadratic Saturation)	
Appendix B3: CSVGN1 Static Shunt Compensator Model	
<b>APPENDIX C: RESULTS SUMMARY TABLE.....</b>	<b>35</b>
<b>APPENDIX D: TRANSIENT RESULTS GRAPHS.....</b>	<b>39</b>
Appendix D1: Case D1 – Motor Starting	
Appendix D2: Case D1b – Motor Starting with Circuit A9K Out-of-Service	
Appendix D3: Case D1c – Motor Starting with Circuit A9K Out-of-Service and S&C Model	
Appendix D4: Case D2 – LLG Fault at Kirkland Lake with NP Kirkland Generation Off	
Appendix D5: Case D3 - LLG Fault at Kirkland Lake with NP Kirkland Generation On	

## 1.0 SUMMARY

Northgate Minerals Corporation (Northgate) is proposing late stage development of the Young-Davidson (YD) project located in Matachewan, Ontario, approximately 60 km west of Kirkland Lake. The YD project will consist of 17 MW of load connected to the 115 kV circuit K4 from Kirkland Lake TS. A decommissioned 47.5 km section of line will be upgraded from Macassa Shaft No.3 to Matachewan Junction, and another 7 km of new 115 kV line will be constructed to complete the electrical interconnection.

This assessment indicates that for the cases studied and with the YD recommended requirements implemented, the impact of the proposed project on the IESO-controlled grid is acceptable. The recommended YD requirements include a reactive power compensation system, consisting of static (Capacitor bank) and dynamic (SVC) components. With an 8 MVAR, 118 kV capacitor bank, the SVCs will need a combined continuous output capability of 10.6 MVAR, a minimum 10 second short term capability of 24 MVAR output, a maximum continuous input capability of 6 MVAR and a maximum initial response time of 500 msec. These are the minimum requirements necessary to maintain system voltages during contingencies and motor starting according to ORTAC guidelines – ie no lower than 113 kV. The 8 MVAR capacitor bank should normally be energized in order to maintain 118 kV at the YD bus, which will minimize the output of the SVCs during normally operating conditions.

The capacitor bank will be installed on the YD high voltage bus and will be operated normally in service, switching out of service automatically at 125 kV and back into service below 115 kV. The three SVC units will each be sized at 50% of the necessary reactive power requirements, which is during starting of the AG Mill motor. One SVC will be installed on the YD high voltage bus and the remaining two SVC units will be installed on the two YD main low voltage buses. All three units, in conjunction with the normally energized capacitor bank, will be configured to control the high voltage YD bus to a minimum set point of 118 kV. This configuration will ensure reliability in the event that one of the devices is down for maintenance, which is one of the IESO contingencies that must be met.

An operational study is required in order to ensure that the manufacturer's equipment meets the technical requirements assumed in this assessment.

## 2.0 INTRODUCTION

Northgate is proposing to redevelop a gold mine in Matachewan, Ontario, near Kirkland Lake. The Young Davidson project will be connected to the 115 kV circuit K4 from Kirkland Lake TS. Currently this circuit extends 9km east of Kirkland Lake TS to Macassa Shaft No. 3. In order to facilitate the Young-Davidson project, 47.5 km of decommissioned 115 kV line will be upgraded from Macassa Shaft No. 3 to Matachewan Junction. Another 7 km of new 115 kV line will extend from Matachewan Junction to the Young-Davidson substation.

The YD project consists of two 115 kV–13.8 kV transformers supplying a peak load of 17 MW. The largest load in the project is the AG Mill with a load requirement up to 6,000 kW. For system modelling purposes, this load is simulated separately with the remainder of the mine load lumped and balanced across the two low voltage buses.

The purpose of this System Impact Assessment is to examine the feasibility of the proposed connection arrangement of the project and the impact of the new load facility on the local transmission facilities. This study reviews the steady state, transient voltages and equipment thermal ratings during various contingency outages and starting the largest YD motor.

The study was completed using the Power Technologies Inc. (PTI) Power System Simulator (PSS/E), version 30.2 analysis software, in accordance with the IESO Ontario Resource and Transmission Assessment Criteria (ORTAC)<sup>1</sup>. An initial model for the Ontario transmission system was provided by the IESO in order to determine the impact of the proposed YD load facility on the existing system.

---

<sup>1</sup>Independent Electricity System Operator, Ontario Resource and Transmission Assessment Criteria, Document ID: IMO\_REQ\_0041, Issue 5.0, August 22, 2007.

### 3.0 EXISTING SYSTEM

Northgate is proposing to connect the YD project to the 115 kV transmission system in the Northeast area of Ontario (see Appendix A1). The existing circuit extends 7 km southwest from Kirkland Lake TS to Macassa Shaft LAC Minerals, and a further 1.9 km to Macassa Shaft No. 3. The existing load on the K4 line is 8 MW.

Other 115 kV circuits extending from Kirkland Lake TS include the double circuit line A8K/A9K to Ansonville TS, D3K to Dymond TS, and the radial circuit K2 to Kirkland Lake Power and Barrick Gold. The closest generation facilities to YD are NP Kirkland Lake and Lower Notch. The status of these generating stations is varied during the study in order to simulate the worst-case scenario for individual test cases. For the majority of tests, this corresponds to both facilities out of service.

### 3.1 BASE CASE CONFIGURATION

The basis of the assessment is the IESO winter 2008-2009 system model with the following changes or additions made to the Northeast Ontario area:

- Coincident peak load conditions for Northeastern Ontario scaled to 1830 MW. This is the forecast peak load in the area as of the project's in-service date based on median growth forecast with normal weather conditions;
- Dymond Area Load (DAL) is 110 MW (see Appendix A2);
- Local loads are as per historical non-coincident peak (see Appendix A3);
- Load on the K4 line is 8 MW;
- Load on the K2 line is 11 MW (flow from Kirkland Lake TS including losses);
- 23.3 MW load at Kirkland Lake TS;
- Power factor at existing load facilities is assumed to be 0.9;
- All existing transmission facilities are assumed to be in service;
- Both Pinard reactors out of service;
- Only Hanmer reactor R7 in service (51 MVAR);
- 13.44 MVAR capacitor SC11 on the 115 kV Kirkland Lake bus is on;
- One of the 24 MVAR capacitors on the 115 kV Dymond bus is on;
- The proposed SVC at Kirkland Lake TS is not in service;
- Ansonville TS transformer adjusted to obtain 125 kV at Ansonville and set to manual control;
- Dymond TS transformers set to manual control;
- Porcupine TS autotransformers T3 and T4 regulating voltage between 126 kV – 131 kV;
- Generation dispatch is based on the historical typical conditions;
- NP Iroquois Falls, TCPL Tunis, NP Cochrane, and Long Sault generation are in service; and
- For the transient analysis, an acceleration factor (ACC) of 0.5 and delta time step (DELTA) of 0.001 were used for all cases.

## 4.0 PROPOSED SYSTEM

### 4.1 DESCRIPTION OF YOUNG-DAVIDSON

In order to facilitate the Young-Davidson project, 47.5 km of decommissioned 115 kV line will be upgraded from Macassa Shaft No. 3 to Matachewan Junction. Another 7 km of new 115 kV line will extend from Matachewan Junction to the Young-Davidson substation. The refurbished and new sections of transmission line from Macassa No. 3 to Young-Davidson will be equipped with 795 kcmil, ACSR conductors (Drake) with a maximum conductor operating temperature of 100°C. The impedance of the new conductor in per unit per kilometre on a 100 MVA, 118.05 kV base is shown in the table below.

**Table 4.1: New K4 Conductor Impedance**

	<b>Impedance in pu / km</b>
R	0.003131
X	0.003249
B	0.000359

Emergency power for the project will be supplied by back-up generators on site. These generators will not be paralleled with the IESO grid.

The Young-Davidson 115 kV substation will be equipped with three 120 kV-13.8 kV Delta-Wye transformers, with two transformers operating in parallel to supply the plant load, five 145 kV motorized disconnect switches, one IESO compliant Revenue Meter system including a set of outdoor 115 kV CT/VT combination units, one set of outdoor 115 kV CCVTs for metering and protection, two 145 kV circuit breakers, four sets of station class surge arresters and one 8 MVAR capacitor unit.

The power delivered via the new transmission line is stepped down at the site via two 120 kV-13.8 kV 12/16/20 MVA ONAN/ONAF/ONAF transformers. Both transformers have 6% impedance on a 12 MVA base.

The project will consist of a total load of approximately 17 MW that will be supplied through two 13.8 kV busbars. The largest load in the project is the AG Mill with a capacity up to 6,000 kW. The proposed motor is a synchronous machine with a nameplate speed of 180 RPM, leading power factor of 90%, and efficiency of 96%. The voltage starting characteristics of the AG Mill can be found in Appendix A4 and the open and short circuit saturation curves in Appendix A5. This load is supplied at 4.16 kV, via a 13.8 kV-4.16 kV Delta-Wye 9/12 MVA transformer with 5.75% impedance on a 9 MVA base. Other areas of the mine with large combined loads include the underground development with a peak load of 3.8 MW and the underground power distribution at 3.9 MW.

The Young-Davidson project will have a significant impact on the total load on the K4 line, increasing it from 8 MW to 25 MW.

A single line diagram of the YD configuration and local system facilities is shown in Appendix A6.

## **4.2 SYSTEM MODELLING SETTINGS**

### **4.2.1 AG Mill Load**

The YD project will use an existing AG Mill that has two 4,476 kW synchronous motors operating at a leading power factor of 0.9 PF. The maximum total AG Mill load for full production is 6,000 kW. The AG Mill motors will be started individually, and not simultaneously. For the load flow studies, the AG Mill was represented as a single load on a 4.16 kV bus with a real power requirement of 6 MW. The motor supplies 2.9 MVAR of reactive power to the grid during normal operation. A single 6 MW load is sufficient for both load flow and dynamic analyses.

For the transient analysis, two models were used to simulate the AG Mill. The CIM5BL induction motor load model was selected for the motor starting studies as shown in Appendix B1. This model accurately provides the starting characteristics of the AG Mill and the associated reactive power support requirement during motor starting. After the motor has reached synchronous speed, this model is no longer valid. At this point, the synchronous machine returns to steady state conditions as established in the load flow analysis. For the transient fault analyses, the GENROU model shown in Appendix B2 was chosen. To enable this simulation, a generator model with negative power and positive reactive power equivalent to the AG Mill capacity was used in load flow.

### **4.2.2 Young-Davidson VAR Support**

During the course of analysis, it was determined that dynamic reactive compensation would be required at the YD project site. For load flow studies, the static VAR compensation (SVC) units were modelled as two generators with a high MVAR capability in order to determine the MVAR requirements. The units were installed on each of the two low voltage YD buses and were set to control the voltage at the high voltage YD bus to a minimum transient of 113 kV in order to determine the minimum amount of VAR support required to meet ORTAC standards. (Operation of the units at site will use a setpoint of 118 kV, as described in section 6.6.) For the transient analysis, the CSVGN1 static shunt compensator model shown in Appendix B3 was used to represent the SVC. Conservative parameters were selected for use in the model, on the expectation that the SVC installed will meet or exceed the performance in this analysis. For example, a 500 ms delay on starting was used in the model. Information from a number of manufacturers confirms that units can be purchased with much faster starting times. In addition to the CSVGN1 model, the S&C Electric DSTATCOM SVC model was tested during the worst case motor starting study as one example of a manufacturer's standard equipment.

### **4.2.3 Other**

The remaining YD loads were lumped and balanced across the two YD low voltage buses and modelled in the transient and short circuit studies as 95% constant MVA and 5% constant admittance. System modelling settings not described in this report are as provided by the IESO.

## 5.0 SYSTEM STUDY PARAMETERS

### 5.1 DESCRIPTION OF TEST CASES

The addition of the Young-Davidson project to the transmission system was studied under normal conditions, contingencies, and faults that were stipulated by the IESO. Computer simulations included power flow, short circuit, and transient analyses. The test cases are summarized below.

**Table 5.1: Summary of Test Cases**

	Case	YD In-Service	Area Generation In-Service	Contingency
<b>Short Circuit</b>	SC1	Yes	Yes	Three-phase fault
	SC2	Yes	Yes	Line-to-ground fault
<b>Thermal Analysis</b>	A1	No	Yes	NONE
	A2	Yes	Yes	NONE
<b>Steady State Voltage Analysis</b>	B1	Yes	No	NONE
	B2	No	No	Loss of YD project
	B3	Yes	No	Loss of largest reactive source at YD
	B4	Yes	No	230 kV line outage - W71D
	B5	Yes	No	115 kV line outage D3K + Dymond SC11 + Dymond T3
	B6	Yes	No	115 kV line outage A9K + Kirkland SC11
	B7	Yes	No	115 kV line outage A8K + Kirkland T12
	B8	Yes	Yes (Kirk4&5 <sup>1</sup> )	Outage of line D3K + Dymond SC11 + Dymond T3 + NP Kirkland Lake Generators 1, 2, 3, and 6
<b>Steady State Motor Starting</b>	C	Yes	No	Start AG Mill motor with all other site loads operating Voltage Dependent Load
<b>Transient Voltage Analysis</b>	D1	Yes	No	Starting of most critical YD motor with CSVGN1 SVC model
	D1b	Yes	No	Starting of most critical YD motor after outage of A9K with CSVGN1 SVC model
	D1c	Yes	No	Starting of most critical YD motor after outage of A9K with S&C

	Case	YD In-Service	Area Generation In-Service	Contingency
				DSTATCOM model
	D2	Yes	No	LLG fault at Kirkland Lake TS with CSVGN1 SVC model
	D3	Yes	Yes	LLG fault at Kirkland Lake TS with CSVGN1 SVC model
<b>Additional tests with YD reactive compensation system<sup>2</sup></b>	E	Yes	No	Local generation O/S, YD SVC's O/S. Test YD capacitor bank switching
	E6	Yes	No	Same as case B6 above, post-contingency, post-ULTC with proposed reactive compensation system <sup>2</sup>
	E8	Yes	Yes (Kirk4&5 <sup>1</sup> )	Same as case B8 above, pre-contingency with proposed reactive compensation system**
<b>Limit tests with YD reactive compensation system<sup>3</sup></b>	F1	No	No	Kirkland Lake voltage at base case levels, base case settings as in section 3.1, YD load 0MW, test both 2 and 3 SVCs
	F2	Yes	No	Same as case F1 with YD load 17 MW
	F3	No	Yes	Kirkland Lake voltage at maximum (127 kV), DAL = 55 MW, both Dymond TS capacitor banks off, all Kirkland Lake generation in service, YD load 0MW, test both 2 and 3 SVCs
	F4	Yes	Yes	Same as case F3, but with 17 MW YD load

<sup>1</sup> All NP Kirkland Lake Power generators are in service pre-contingency, and generators G4 and G5 remain in service post-contingency.

<sup>2</sup> For the tests indicated, "proposed reactive compensation system" includes two SVC units with one installed on each of the two low voltage YD buses and one 8 MVAR capacitor bank installed on the high voltage YD bus. SVC voltage set point is 118 kV on the high voltage YD bus for both SVC's.

<sup>3</sup> For Cases F1 to F4, voltages are also examined with all three SVC's in service. The conditions are the same as <sup>2</sup>, except that the third SVC, installed on the high voltage YD bus, is also operating.

## 5.2 SYSTEM CONSTRAINTS

According to ORTAC, the system voltages for both continuous operation and immediately following a contingency must be within specified ranges. These are specified in the table below.

**Table 5.2: ORTAC Acceptable System Voltages**

	<b>Nominal Bus Voltage</b>	<b>500 kV</b>	<b>230 kV</b>	<b>115 kV</b>	<b>Transformer Stations (eg. 44, 27.6, 13.8 kV)</b>
<b>Pre-Contingency Voltage Limits</b>	Maximum continuous	550 kV	250 kV	127 kV <sup>4</sup>	106%
	Minimum continuous	490 kV	220 kV	113 kV	98%
<b>Voltage Changes Immediately Following a Contingency</b>	% Voltage change pre-ULTC	10%	10%	10%	10%
	% Voltage change post-ULTC	10%	10%	10%	5%
	Maximum value	550 kV	250 kV	127 kV	112% of nominal
	Minimum value	470 kV	207 kV	108 kV	88% of nominal

<sup>4</sup> From ORTAC<sup>1</sup>: “Certain buses can be assigned specific maximum and minimum voltages as required for operations. In northern Ontario, the maximum continuous voltage for the 115 kV system can be as high as 132 kV.

Current flows must not exceed the circuit ratings defined in the PTI model provided by the IESO.

For transient voltage studies, the voltage drop following a fault must remain above 70% of the nominal voltage and must not remain below 80% of the nominal voltage for greater than 250 ms within 10 sec after a fault.

During YD motor starting, the voltage flicker at delivery point buses must not exceed 4%. This criterion assumes infrequent starting of the AG Mill motor, which is appropriate as the motor may be started no more than once per week.

## 6.0 IMPACT ON THE IESO-CONTROLLED GRID

### 6.1 SHORT CIRCUIT ASSESSMENT

The purpose of the short circuit assessment is to evaluate the maximum short circuit current contribution of the Young-Davidson project into the IESO-Controlled Grid. Pre-contingency voltages are assumed to be at maximum levels and all local generation resources are in-service. In order to achieve the maximum voltage at YD, local loads on K4 were modelled with zero demand and all YD loads were modelled as operating with 5% demand, i.e. all YD loads contributing to the fault. All three SVC units were assumed to be in service with their maximum overload output of 300 % of 8 MVA<sub>r</sub>, or 24 MVA<sub>r</sub> each.

The fault contribution of the YD project was calculated for both a three phase fault and a line-to-ground fault in the transmission system at Matachewan Junction. Both symmetrical and asymmetrical values were determined. The results are summarized in the table below.

**Table 6.1: YD Short Circuit Contribution Assessment Results**

Case	Description	Symmetrical Current (Amps rms)		Asymmetrical Current (Amps rms)
SC1	Three-phase fault	554		648
SC2	Line-to-ground fault	I <sub>a</sub>	310	-
		523	703	823

### 6.2 THERMAL ANALYSIS

The thermal assessment determined the impact of YD on the thermal ratings of the existing transmission facilities. The analysis includes an evaluation of the pre-contingency thermal impact on the 115 kV circuit K4 (Case A1) and a comparison of the flows on the existing system and the system with YD connected (Case A2).

All local generation was assumed to be in-service for the thermal analysis, including NP Kirkland Lake and Lower Notch. YD loads were modelled as constant MVA.

Summaries of the thermal analysis and line losses follow. No overcurrent issues were identified.

**Table 6.2: Summary of Thermal Analysis**

From	To	Current (A)		
		Case A1	Case A2	Rated
Kirkland Lake TS	Macassa MJ	38	120	260
Macassa MJ	Macassa No. 3	24	106	260
Macassa No. 3	Matachewan Jct	-	82	260
Matachewan Jct	Young-Davidson	-	82	260

**Table 6.3: Summary of Line Losses**

From	To	Losses			
		MW		MVA <sub>r</sub>	
		Case A1	Case A2	Case A1	Case A2
Kirkland Lake TS	Macassa MJ	0.01	0.09	0.02	0.16
Macassa MJ	Macassa No. 3	0.00	0.02	0.00	0.03
Macassa No. 3	Matachewan Jct	-	0.43	-	0.44
Matachewan Jct	Young-Davidson	-	0.06	-	0.07

The distribution factors of the new load on the 115 kV circuits A8K, A9K, and D3K are shown in the table below. The distribution factors (DF) are a set of sensitivity coefficients describing the effect of YD on the monitored transmission lines. A DF is defined as follows:

$$DF = \frac{(MW \text{ in new case with YD in service}) - (MW \text{ in base case without YD})}{\text{Power Shift (new YD load of 17 MW)}}$$

The power flow direction is defined as from Dymond to Kirkland Lake (D3K) and from Kirkland to Ansonville (A8K / A9K). As shown in the table, the majority of the YD load is supplied from circuit D3K. 40% of the new 17 MW of load at Young Davidson is supplied via Dymond TS (D3K) and the remaining 60% is supplied from A8K and A9K.

**Table 6.4: Load Distribution Factors**

Circuit	Distribution Factor
A8K	-0.31
A9K	-0.29
D3K	0.40

### 6.3 STEADY STATE VOLTAGE ANALYSIS

The steady state analysis examined the affect of YD on the voltage performance of the system. Load was modelled as voltage dependent for pre-ULTC action and constant MVA pre-contingency and post-ULTC action. Generation at NP Kirkland Lake and Lower Notch was out of service. A table summarizing the voltage performance of relevant nearby buses for the contingencies studied can be found in Appendix C.

With the reactive power support noted in Table 6.5, all contingency cases meet the ORTAC requirements. Under normal conditions with all YD loads operating, no additional reactive power is needed to support the voltage at the YD site. The reactive power requirement shown in Table 6.5 can be supplied by either static capacitors or dynamic SVCs.

The maximum reactive power requirement for system contingencies necessary to maintain at least 113 kV at the YD bus is 10.6 MVA<sub>r</sub>, as determined by Case B6, the loss of circuit A9K from Ansonville to Kirkland Lake. With an 8 MVA<sub>r</sub> capacitor in service,

the SVCs will only need to provide a total of approximately 2.6 MVAR to meet the steady state contingency cases.

The loss of one of the three SVC units comprises contingency case B3, loss of the largest reactive source on site. Since all steady state and contingency cases studied were performed with only two of the three SVC's in service, Case B3 will have acceptable results even when combined with the worst case transmission line outage scenario.

**Table 6.5: Steady State Voltage Analysis YD SVC Requirement**

Case	MVAR Required to keep YD bus above 113.0 kV	
	Pre-ULTC	Post-ULTC
B2	0.0	0.0
B3	-	-
B4	0.0	0.8
B5	4.4	5.6
B6	8.8	10.6
B7	2.6	4.2
B8	0.0	0.0

#### 6.4 STEADY STATE MOTOR STARTING ANALYSIS

The steady state motor starting analysis determined the affect of starting the motor that causes the largest voltage drop at the YD site on the IESO-controlled grid. Since the starting of YD motors can be staggered, the worst case motor starting study is defined as the starting of the motor with the largest MVA inrush with all other site loads in service. This motor is the AG Mill, with a maximum load of 6,000 kW. All loads were modelled as voltage dependent and NP Kirkland Lake and Lower Notch Generation were out of service. The motor starting studies assumed that 11 MW of YD load was already in service, including one of the AG Mill motors operating at lagging PF. This is a worst case scenario from the project perspective.

A table summarizing the voltage performance of relevant nearby buses for this study can be found in Appendix C. Voltage performance is shown pre-ULTC action. All steady state voltage declines are acceptable for this worst case scenario.

#### 6.5 TRANSIENT VOLTAGE ANALYSIS

The dynamic performance of the YD project during contingency scenarios was examined in the transient voltage analysis. Two motor starting cases and two line-to-line-to-ground (LLG) fault cases were studied.

##### 6.5.1 Motor Starting

As with the steady state motor starting analysis, the worst case transient motor starting study was defined as the starting of the AG Mill with all other site loads in service. This motor has the largest MVA inrush.

Two cases were identified for the motor starting studies. Case D1 examines starting of the AG Mill motor with all local system facilities in service, with the exception of NP

Kirkland Lake and Lower Notch generation. Case D1b looks at motor starting with the outage of one transmission line after the system has been re-dispatched and the voltages and flows have been adjusted so that the system is operating within normal parameters. The worst-case transmission line outage in the scope of this study – the loss of circuit A9K – was used for this motor starting case.

Starting time for the AG Mill was approximately six seconds in both cases. For the first six seconds following motor starting, the total short time reactive power overload capability of about 24 MVAR is required in order to maintain a voltage drop of no more than 4% voltage at the nearest customer's 115 kV bus in both motor starting study cases. The dynamic reactive power support for motor starting is summarized in Table 6.6. Post-motor starting values of reactive power support correspond to the steady state conditions for the synchronous motor as determined in the load flow analysis. As outlined in section 4.2.1, the CIM5BL model is only applicable for this motor starting study until the motor reaches synchronous speed. The dynamic response graphs can be found in Appendices D1 and D2.

Case D1c is a repeat of motor starting case D1b, with the A9K outage, except using the S&C Electric DSTATCOM SVC model (version 4d). This is one example of a standard manufacturer's SVC that could be utilized for this project. The unit size used was -2.5 MVAR to +8.75 MVAR range, based on S&C's standard 1.25 MVAR modules. The maximum overload capability is 264% for 2 seconds with 1.25 MVAR modules; longer overload duration will occur when the overload peak is less than 264 %. This SVC is larger than the required SVCs determined in cases D1 and D1b, which produced acceptable results. Case D1c test results are shown in the dynamic response graphs in Appendix D3. The SVCs in case D1c produced more MVAR than in cases D1 and D1b (28 MVAR vs 24 MVAR), which provided a better voltage profile during motor starting.

### 6.5.2 Line-to-Line-to-Ground (LLG) Fault

Two fault cases were identified for study. Both Case D2 and D3 examine a line-to-line-to-ground fault (LLG) at Kirkland Lake TS with normal clearing time, such that circuit D3K and NP Kirkland Lake GS are lost by configuration. Case D2 looks at this case with NP Kirkland Lake generation out of service, and Case D3 is studied with NP Kirkland Lake generation in-service. Both tests are studied with Lower Notch generation out of service.

With Kirkland Lake generation out of service in Case D2, transient oscillations die out after 3.5 seconds. For Case D3, oscillations continue for 4.5 seconds. Both LLG fault cases are well within the transient voltage sag range as defined in ORTAC. Voltage oscillations at YD and at Macassa are minimal post-fault. Voltage levels return to pre-fault levels within 10 seconds.

Dynamic reactive power support for the LLG fault studies are summarized in Table 6.6. Continuous requirements are approximately 5.5 MVAR for both Cases D2 and D3. The transient response graphs can be found in Appendices D4 and D5.

### 6.5.3 Dynamic SVC Requirements

The dynamic VAR compensation requirements for the dynamic study cases are summarized below. Peak ratings are specified for SVC output immediately following motor starting for Cases D1 and D1b and post-fault for Cases D2 and D3.

**Table 6.6: Transient Study YD SVC Requirement**

Case	MVAR Required			
	Peak	Post Motor Starting	Pre-Transient	Post- <sup>5</sup> Transient
D1	23.3	0.0	-	-
D1b	23.8	10.6	-	-
D2	-	-	0.0	5.5
D3	-	-	0.0	5.6

<sup>5</sup> With D3K out of service following a LLG fault at Kirkland Lake TS.

## 6.6 SUMMARY OF YD SVC REQUIREMENTS

For system reliability purposes, a reactive compensation system is required, which can consist of both static (Capacitor bank) and dynamic (SVC) components. In order to permit the AG Mill motor to be started with transmission line A9K and one SVC out of service and still maintain minimum voltages, as determined by Case D1b, an 8 MVAR, 118 kV capacitor bank and three SVCs will be needed. The combined SVC requirements will need a continuous output capability of 10.6 MVAR, a minimum 10 second short term output capability of 24 MVAR, a maximum continuous input capability of 6 MVAR and a maximum initial response time of 500 msec in order to maintain minimum voltages as defined by ORTAC. Based on the above requirement and using three 50 % units, each SVC will need a minimum continuous output capability of 5.3 MVAR, a minimum 10 second short term output capability of 12 MVAR, a maximum continuous input capability of 2 MVAR and a maximum initial response time of 500 msec.

The 8 MVAR capacitor bank should normally be energized in order to maintain the YD bus at 118 kV, which will minimize the output of the SVCs during normally operating conditions. All three SVCs will normally be in service with a set point of 115 kV.

The coordination philosophy of the SVC units will be as follows: SVC-HV on the YD 115 kV bus will have the fastest response time, followed by SVC-LV1 on the YD low voltage bus that serves the AG Mill, and SVC-LV2 will have the slowest response time.

The capacitor bank will be installed on the high voltage YD bus and operated normally in service. To mitigate the risk of high voltage levels, the capacitor bank will be automatically switched out of service when the YD voltage increases above 125 kV and back in service when the YD voltage decreases below 115 kV. The capacitor bank will also be equipped with manual override. System studies have shown that high voltage levels at Kirkland Lake (127 kV and above) result in proportionately lower voltages at YD when the capacitor bank is out of service, even during low load scenarios at both YD and in the Dymond Area.

In the event of loss of the main supply to YD (115 kV transmission line K4), the capacitor bank will be tripped. It will return to service following a 5 minute time delay after the reconnection of the 115 kV line. In the same outage scenario, the circuit breakers for the large motors will trip on undervoltage prior to the transmission line automatically reclosing.

The reactive power compensation system is designed to minimize the output of the SVC's. An operational limit study by the manufacturer is required to determine the detailed specifications of the system.

**6.7 ADDITIONAL TESTS WITH YD REACTIVE COMPENSATION SYSTEM**

The worst case line outage contingency (loss of A9K, Case B6) was studied with the addition of the proposed YD reactive compensation system with a voltage setpoint of 118 kV. With two SVC's and the capacitor bank in service, the total reactive power required from the YD reactive compensation system in order to keep the YD bus at 118 kV is 21 MVAR (8 MVAR capacitor bank plus 6.5 MVAR from each of the two SVCs'). By allowing the YD bus voltage to drop to 115 kV then no more than 5.3 MVAR continuous is required from each of the two SVCs.

As seen in Appendix C, the addition of the 8 MVAR capacitor to the case study with the highest voltage levels (Case B8, pre-contingency) results in a 2% increase in the YD voltage levels. The voltage on the main 115 kV bus increases from 120.1 kV to 122.8 kV. System voltage increases are limited to 1% or less for all monitored buses.

Switching of the YD 8 MVAR capacitor bank was studied in order to ensure that it did not cause a voltage change greater than 4 %. The study case parameters included: all local generation out-of-service, maximum Dymond Area Load of 110 MW, and the YD SVC units out-of-service. The results are shown in Appendix C (Case E), and meet the IESO requirements.

**6.8 LIMIT TESTS WITH YD REACTIVE COMPENSATION SYSTEM**

The affect of the YD reactive compensation system on system voltages was studied under base and maximum voltage levels at Kirkland Lake TS and minimum and maximum YD load. All voltages are within acceptable levels (see Appendix C, Cases F1, F2, F3, F4). The output of the SVC's and capacitor bank for each test is summarized below.

**Table 6.7: Limit Tests - SVC and Capacitor Output**

Case	No. of SVC's	Output of ea. SVC (MVAR) <sup>6</sup>	Output of Cap Bank (MVAR)	Net Output (MVAR)	YD 115 kV Bus Voltage (kV)
F1	2	-2	8	4	122.9
F1	3	-2	8	2	122.0
F2	2	0.4	8	8.8	118.1
F2	3	0.3	8	8.9	118.1
F3	2	-2	0 <sup>7</sup>	-4	125.1
F3	3	-2	0 <sup>7</sup>	-6	124.5
F4	2	-2	8	4	123.0
F4	3	-2	8	2	122.3

- 6 -2 MVar is the minimum SVC output
- 7 The YD capacitor bank switches out when the voltage on the YD bus reaches 125 kV.

## 7.0 CONCLUSIONS

The impact of the YD project on the IESO-grid was studied during line outage contingencies, motor starting, and faults. The simulation results indicate that the impact of the Young-Davidson project on the IESO-grid is acceptable provided a reactive compensation system is implemented. The results are contingent on each 4,476 kW synchronous AG Mill motor starting individually and not simultaneously, with a maximum total AG Mill load during full production of 6,000 kW. The motor starting tests using a 6,000 kW motor are thus conservative enough to cover the maximum motor starting requirement of 4,476 MW.

As a minimum, the reactive compensation system needs to include a continuous reactive power capability of 18.6 MVAR, with a short term capability of 32 MVAR for 10 seconds. Based on one 115 kV capacitor bank and three SVCs, the recommended arrangement is with the capacitor bank and one of the SVC units installed on the 115 kV YD bus and the remaining two SVC units installed on each of the two main low voltage YD buses. This configuration ensures that there are no performance issues at the YD site during single contingencies and motor starting.

As determined by the cases studied and with an 8 MVAR, 118 kV capacitor bank, the SVCs will need a combined continuous output capability of 10.6 MVAR, a minimum 10 second short term capability of 24 MVAR output, a maximum continuous input capability of 6 MVAR and a maximum initial response time of 500 msec. Based on the above requirement and using three 50 % units, each SVC will need a minimum continuous output capability of 5.3 MVAR, a minimum 10 second short term output capability of 12 MVAR, a maximum continuous input capability of 2 MVAR and a maximum initial response time of 500 msec.

The study assumes that the proposed Kirkland Lake SVC is not in service. The addition of this SVC into the system will reduce the amount of YD reactive compensation required.

The recommended reactive compensation system enables the successful integration of the Young-Davidson project into the IESO-controlled grid, and permits starting of the AG Mill motor with transmission line A9K and one of the SVCs out of service.

## APPENDICES

- Appendix A: Figures
- Appendix B: PSS/E Modelling Data
- Appendix C: Results Summary Table
- Appendix D: Transient Results Graphs



## **APPENDIX A: FIGURES**

- Appendix A1: One Line Diagram of the Northeastern Ontario Area
- Appendix A2: One Line Diagram of the Dymond Load Area (DAL)
- Appendix A3: 115 kV Circuits K2 and K4 Historical Loads from July 7, 2007 to July 7, 2008
- Appendix A4: Voltage Starting Characteristics for the AG Mill
- Appendix A5: Calculated Open and Short Circuit Saturation Curves for AG Mill
- Appendix A6: One Line Diagram of the Young-Davidson Project



## APPENDIX A1: ONE LINE DIAGRAM OF THE NORTHEASTERN ONTARIO AREA

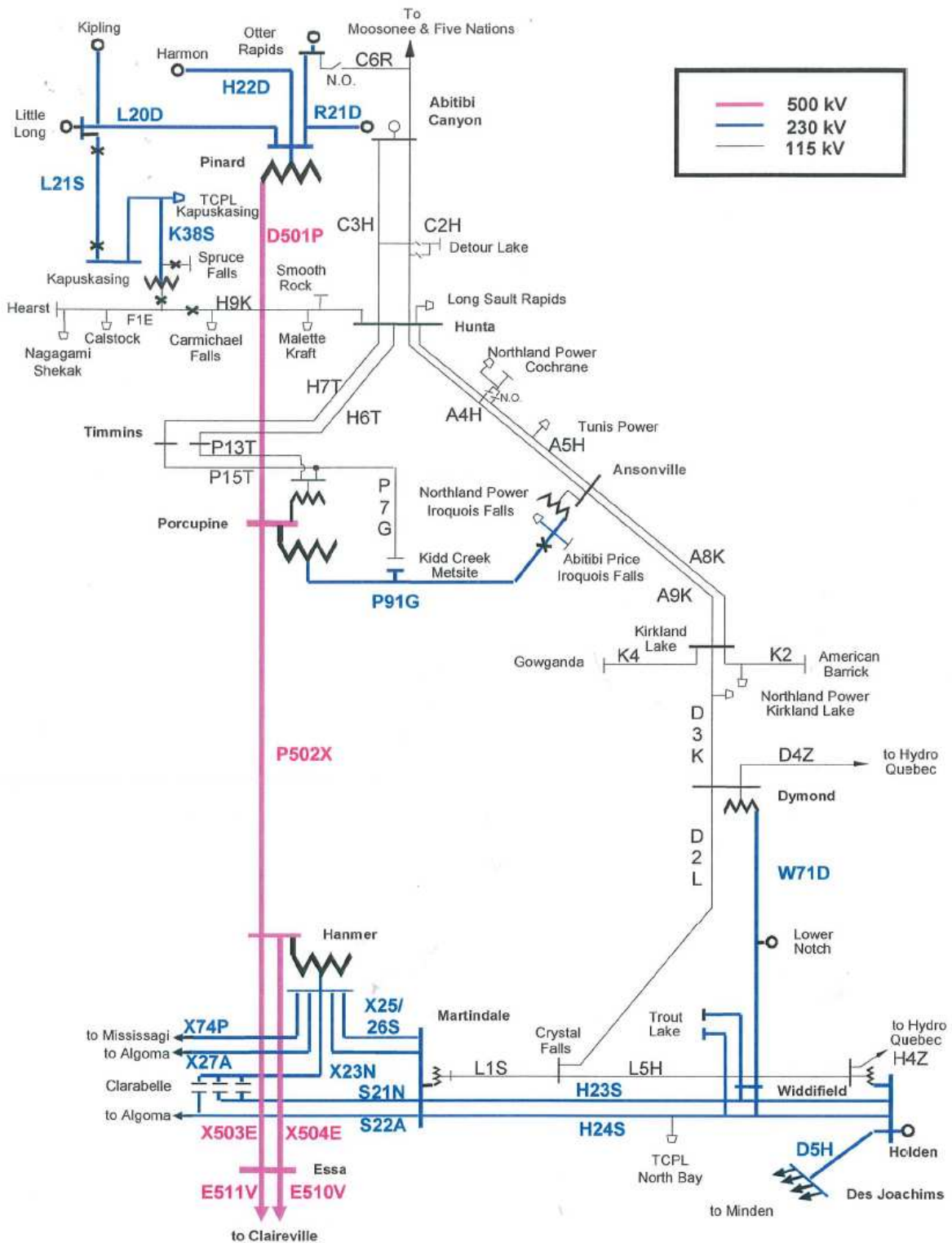

## APPENDIX A2: ONE LINE DIAGRAM OF THE DYMOND LOAD AREA (DAL)

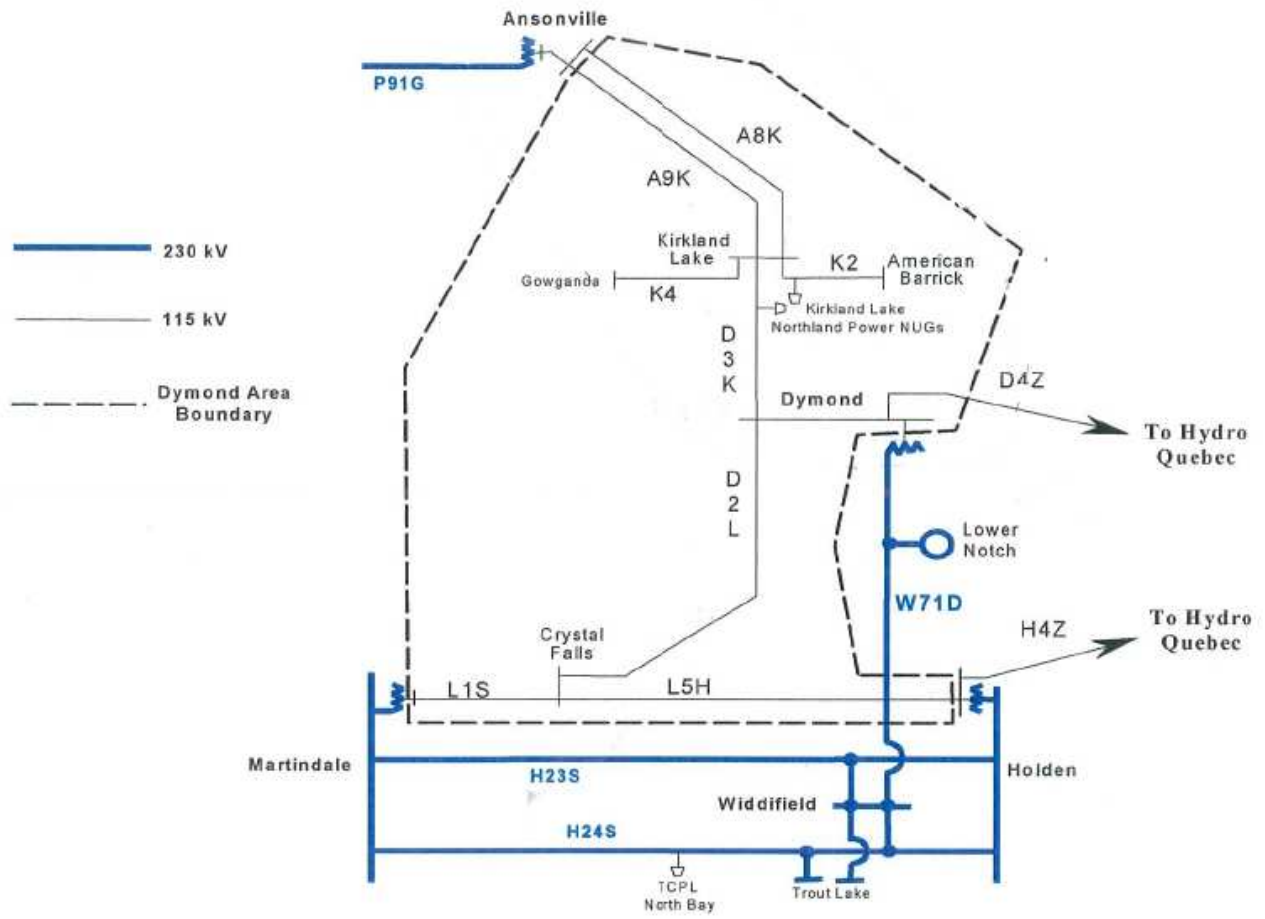

### APPENDIX A3: 115 KV CIRCUITS K2 AND K4 HISTORICAL LOADS FROM JULY 7, 2007 TO JULY 7, 2008

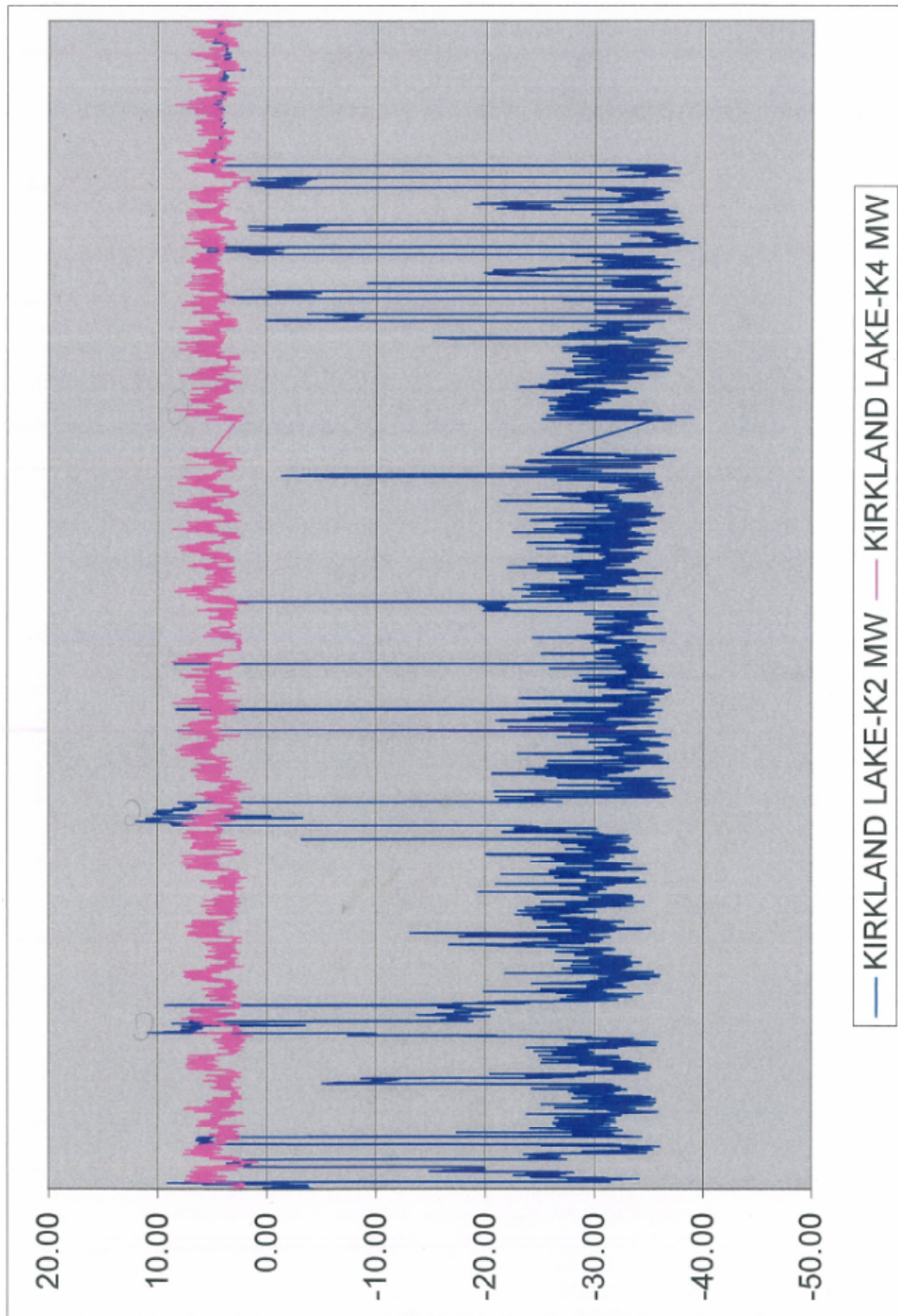

### APPENDIX A4: VOLTAGE STARTING CHARACTERISTICS FOR THE AG MILL

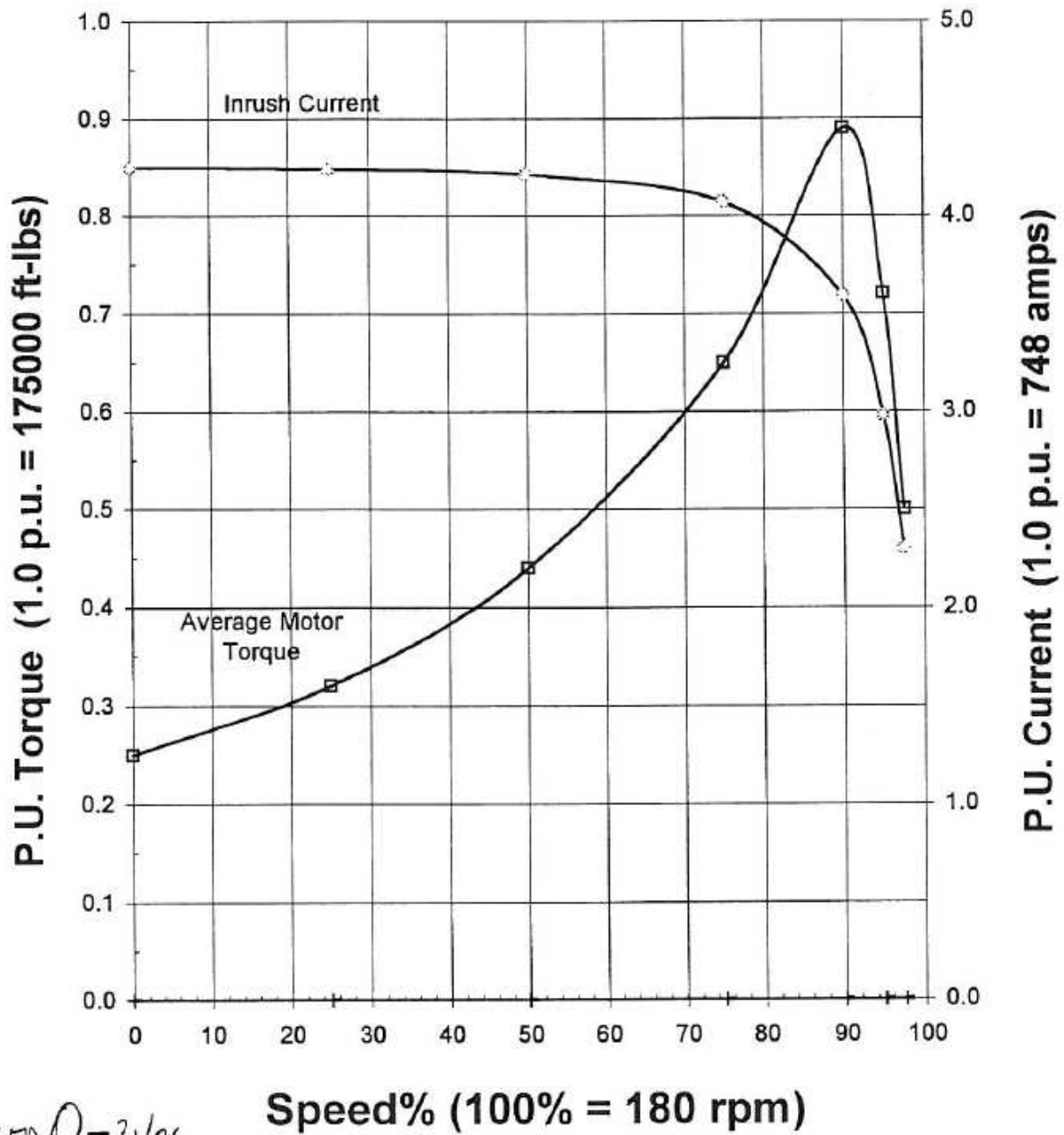

REVISED OCT 21/96

Speed% (100% = 180 rpm)

### APPENDIX A5: CALCULATED OPEN AND SHORT CIRCUIT SATURATION CURVES FOR AG MILL

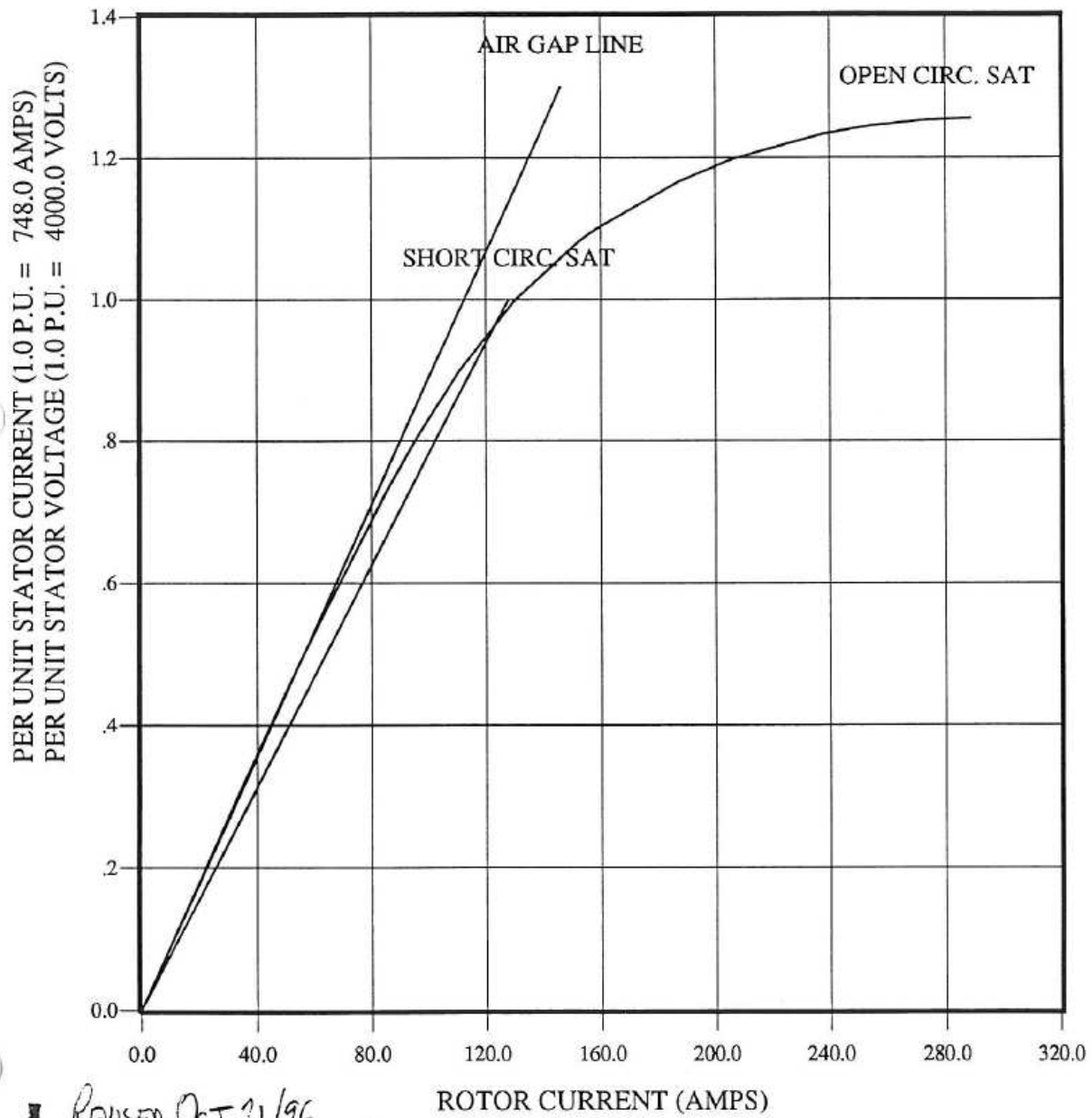

# Appendix A6: One Line Diagram of the Young-Davidson Project

(Case B1 Configuration with 8MVar capacitor bank I/S and 3 YD SVC's not in operation)

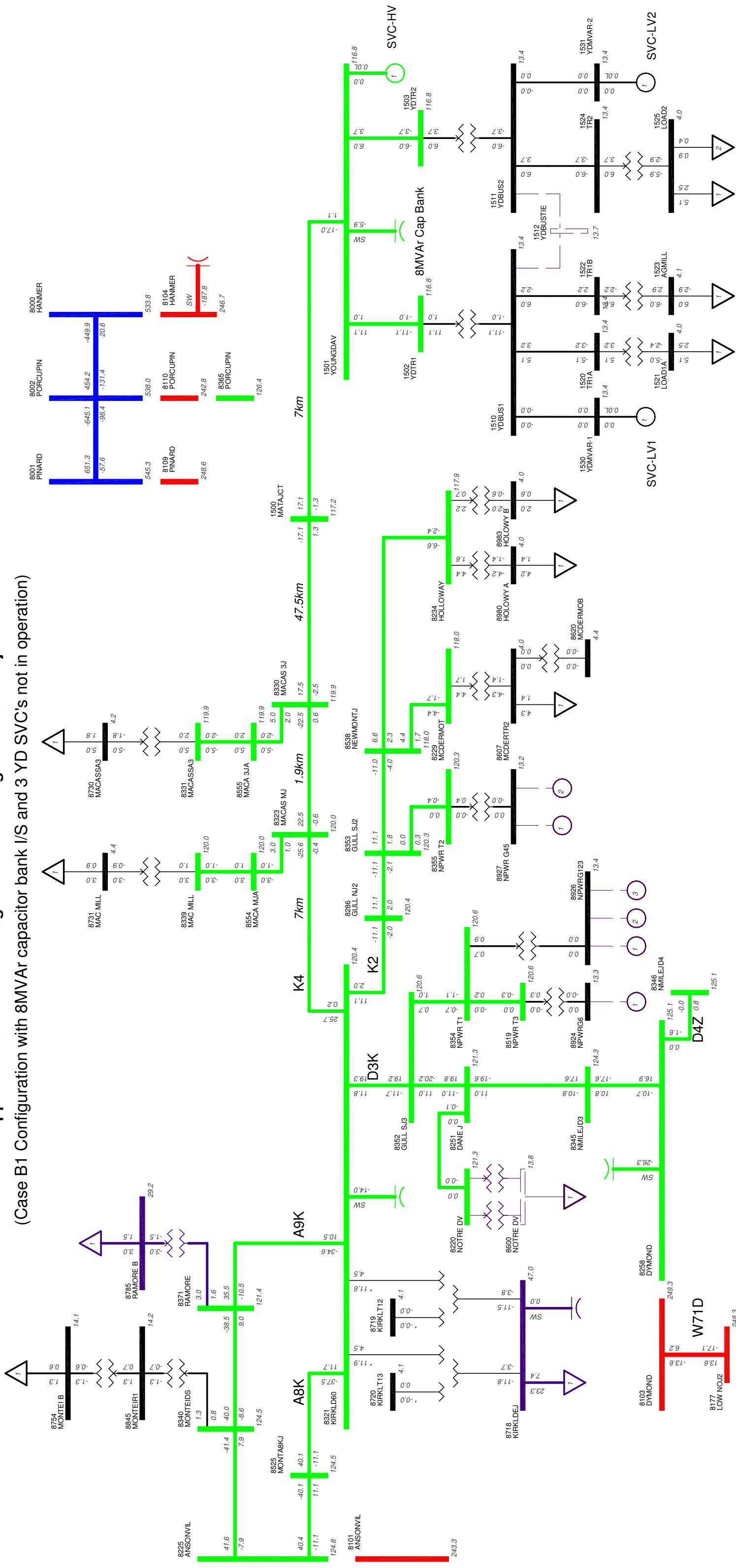

## **APPENDIX B: PSS/E MODELLING DATA**

- Appendix B1: CIM5BL Induction Motor Load Model
- Appendix B2: GENROU Round Rotor Generator Model (Quadratic Saturation)
- Appendix B3: CSVGN1 Static Shunt Compensator Model
- Appendix B4: S&C STATCOM Model (UNIDST Version 4d)



## APPENDIX B1: CIM5BL INDUCTION MOTOR LOAD MODEL

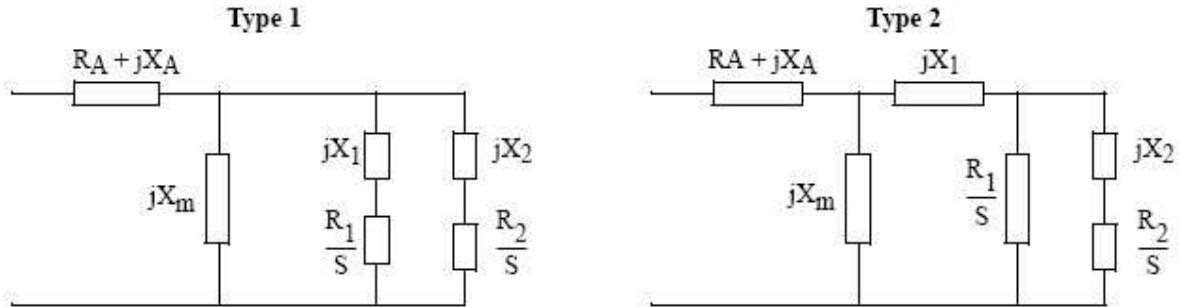

Impedances on Motor MVA Base

**Model Notes:**

1. To model single cage motor: set  $R_2 = X_2 = 0$ .
2. When  $MBASE = 0$ .; motor MVA base =  $PMULT \times MW$  load. When  $MBASE > 0$ .; motor MVA base =  $MBASE$ .
3. Load torque,  $T_L = T (1 + Dw)^D$
4. For motor starting,  $T = T_{nom}$  is specified by the user in CON (J+18). For motor online studies,  $T = T_O$  is calculated in the code during initialization and stored in VAR (L+4).
5.  $V_1$  is the per unit voltage level below which the relay to trip the motor will begin timing. To disable relay, set  $V_1 = 0$ .
6.  $T_1$  is the time in cycles for which the voltage must remain below the threshold for the relay to trip.  $T_B$  is the breaker delay time cycles.

Description	Value
IT (motor type, 1 or 2)	1
RA	0.008
XA	0.13
XM	6.0
R1	0.025
X1	0.1
R2 (0 for single cage)	0
X2 (0 for single cage)	0
E1	1.0
S(E1)	0.17
E2	1.2
S(E2)	0.52
MBASE	6.67
PMULT	0
H (inertia – per unit motor base)	1.5
VI (pu)	0
TI (cycles)	0
TB (cycles)	0
D (load damping factor)	2
Tnom (Load torque at 1 pu speed, used for motor starting only)	0.87

## APPENDIX B2: GENROU ROUND ROTOR GENERATOR MODEL (QUADRATIC SATURATION)

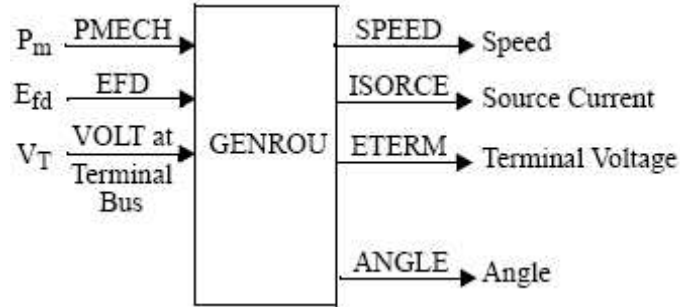

Description	Value
MBASE	6.67
ZSOURCE	0.00 + j0.26
XTRAN	0.00 + j0.00
GENTAP	1.0
T'do	3.5
T''do	0.035
T'qo	0.10
T''qo	0.070
H (inertia)	1.50
D (speed damping)	2.00
Xd	1.28
Xq	0.95
X'd	0.48
X'q	0.95
X''d = X''q	0.26
X1	0.16
S(1.0)	0.17
S(1.2)	0.52

### APPENDIX B3: CSVGN1 STATIC SHUNT COMPENSATOR MODEL

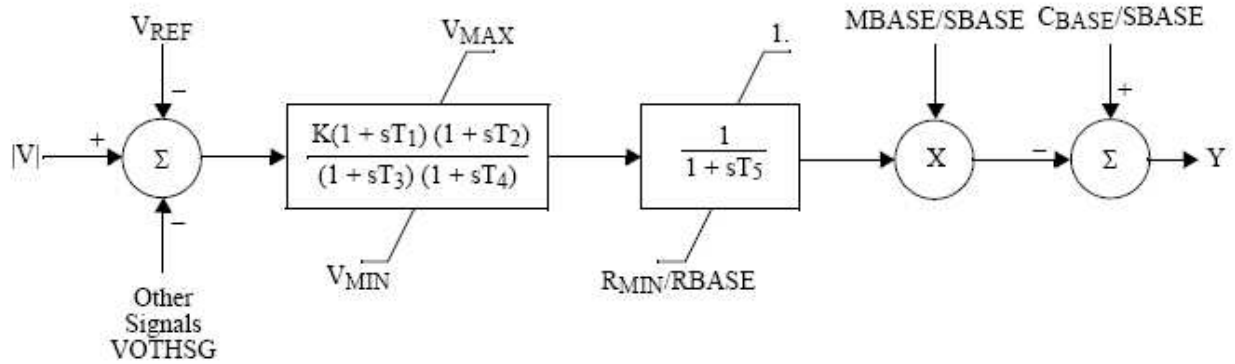

RBASE = MBASE

**Note:** |V| is the voltage magnitude on the high side of generator step-up transformer if present.

Description	Value
K	32
T1	0
T2	0
T3	0.5
T4	0
T5	0
RMIN (Reactor minimum MVar output)	0
VMAX	1.0
VMIN	0
CBASE (Capacitor MVar output)	12
MBASE (MVar range of SVC)	12

## APPENDIX B4: S&C STATCOM MODEL WITH OVERLOAD CAPABILITY

### UNIDST Version 4d, Revised 03/25/08

CONs	Value	Description
J	1	(Kp) Proportional gain constant
J+1	1000	(Ki) Integral gain constant
J+2	8.75	(+ MBASE) +MVAR rating
J+3	-2.5	(-MBASE) -MVAR rating
J+4	0.0	(DB) Voltage Deadband (pu)
J+5	0.30	(UV) Undervoltage pickup (pu)
J+6	1.25	(INV) MVAR rating of inverter module
J+7	0.00	(Kd) Droop constant

## **APPENDIX C: RESULTS SUMMARY TABLE**



Appendix C: Results Summary Table

Bus #	Bus Name	Nominal kV	B1 (BASE)		B2 (LOSEYD)				B4 (W71D)					B5 (D3K)					B6 (A9K + Kirkland SC11)						B7 (A8K + Kirkland T12)					
			Pre-Cont		Post-Contingency				Pre-Cont		Post-Contingency			Pre-Cont		Post-Contingency			Pre-Cont		Post-Contingency				Pre-Cont		Post-Contingency			
			kV	kV	kV	Pre-ULTC kV	Change %	Post-ULTC kV	Change %	kV	Pre-ULTC kV	Change %	Post-ULTC kV	Change %	kV	Pre-ULTC kV	Change %	Post-ULTC kV	Change %	kV	Pre-ULTC kV	Change %	Post-ULTC kV	Change %	w/2SVCs&Cap kV	Change %	kV	Pre-ULTC kV	Change %	Post-ULTC kV
8000	HANMER	500	533.6	533.6	533.7	0%	533.8	0%	533.6	533.0	0%	532.7	0%	533.6	533.0	0%	532.8	0%	533.6	533.2	0%	533.0	0%	533.3	0%	533.6	533.3	0%	533.2	0%
8001	PINARD	500	545.1	545.1	545.2	0%	545.2	0%	545.1	544.9	0%	544.8	0%	545.1	544.5	0%	544.4	0%	545.1	544.7	0%	544.6	0%	544.9	0%	545.1	544.8	0%	544.7	0%
8002	PORCUPIN	500	537.8	537.8	537.9	0%	538.0	0%	537.8	537.8	0%	537.2	0%	537.8	536.9	0%	537.2	0%	537.8	537.2	0%	537.0	0%	537.4	0%	537.8	537.3	0%	537.2	0%
8101	ANSONVIL	220	243.0	243.0	243.9	0%	243.4	0%	243.0	242.8	0%	242.7	0%	243.0	242.3	0%	242.2	0%	243.0	242.8	0%	242.8	0%	243.1	0%	243.0	242.8	0%	242.8	0%
8103	DYMOND	220	248.6	248.6	249.8	0%	250.0	1%	248.6	246.5	-1%	245.9	-1%	248.6	245.9	-1%	245.6	-1%	248.6	246.6	-1%	246.3	-1%	247.8	0%	248.6	247.5	0%	247.2	-1%
8104	HANMER	220	246.6	246.6	246.6	0%	246.7	0%	246.6	246.1	0%	246.0	0%	246.6	246.3	0%	246.2	0%	246.6	246.4	0%	246.3	0%	246.5	0%	246.6	246.4	0%	246.4	0%
8109	PINARD	220	248.5	248.5	248.5	0%	248.6	0%	248.5	248.5	0%	248.4	0%	248.5	248.3	0%	248.3	0%	248.5	248.4	0%	248.4	0%	248.4	0%	248.5	248.4	0%	248.4	0%
8110	PORCUPIN	220	242.7	242.7	242.8	0%	242.8	0%	242.7	242.5	0%	242.4	0%	242.7	242.1	0%	242.0	0%	242.7	242.3	0%	242.3	0%	242.5	0%	242.7	242.4	0%	242.3	0%
1500	MATAJCT	118.05	114.7	114.7	121.5	6%	121.8	6%	114.7	113.7	-1%	113.6	-1%	114.7	113.5	-1%	113.4	-1%	114.7	113.3	-1%	113.3	-1%	118.1	3%	114.7	113.5	-1%	113.5	-1%
1501	YOUNGDAV	118.05	114.1	114.1					114.1	113.2	-1%	113.0	-1%	114.1	113.0	-1%	113.0	-1%	114.1	113.0	-1%	113.0	-1%	118.1	3%	114.1	113.0	-1%	113.0	-1%
1502	YDTR1	118.05	114.1	114.1					114.1	113.2	-1%	113.0	-1%	114.1	113.0	-1%	113.0	-1%	114.1	113.0	-1%	113.0	-1%	118.1	3%	114.1	113.0	-1%	113.0	-1%
1503	YDTR2	118.05	114.1	114.1					114.1	113.2	-1%	113.0	-1%	114.1	113.0	-1%	113.0	-1%	114.1	113.0	-1%	113.0	-1%	118.1	3%	114.1	113.0	-1%	113.0	-1%
8220	NOTRE DV	118.05	120.2	120.2	122.2	2%	122.5	2%	120.2	119.2	-1%	119.0	-1%	120.2				120.2	117.2	-3%	117.0	-3%	119.2	-1%	120.2	118.7	-1%	118.4	-2%	
8225	ANSONVIL	118.05	124.5	124.5	125.0	0%	125.1	0%	124.5	124.3	0%	124.2	0%	124.5	123.6	-1%	123.5	-1%	124.5	124.3	0%	124.3	0%	124.7	0%	124.5	124.3	0%	124.3	0%
8229	MCDERMOT	118.05	116.8	116.8	119.0	2%	119.4	2%	116.8	115.8	-1%	115.6	-1%	116.8	114.6	-2%	114.3	-2%	116.8	113.4	-3%	113.0	-3%	115.6	-1%	116.8	115.0	-2%	114.7	-2%
8234	HOLLOWAY	118.05	116.8	116.8	118.9	2%	119.4	2%	116.8	115.8	-1%	115.5	-1%	116.8	114.6	-2%	114.2	-2%	116.8	113.4	-3%	113.0	-3%	115.5	-1%	116.8	115.0	-2%	114.6	-2%
8251	DANE J	118.05	120.2	120.2	122.2	2%	122.5	2%	120.2	119.2	-1%	119.0	-1%	120.2				120.2	117.2	-3%	117.0	-3%	119.2	-1%	120.2	118.7	-1%	118.4	-2%	
8258	DYMOND	118.05	124.6	124.6	125.4	1%	125.5	1%	124.6	123.4	-1%	123.1	-1%	124.6	122.9	-1%	122.8	-1%	124.6	123.4	-1%	123.3	-1%	124.3	0%	124.6	124.0	0%	123.9	-1%
8286	GULL NJ2	118.05	119.2	119.2	121.5	2%	121.8	2%	119.2	118.3	-1%	118.0	-1%	119.2	117.0	-2%	116.8	-2%	119.2	115.8	-3%	115.5	-3%	118.1	-1%	119.2	117.4	-2%	117.1	-2%
8321	KIRKLD60	118.05	119.3	119.3	121.5	2%	121.8	2%	119.3	118.3	-1%	118.0	-1%	119.3	117.0	-2%	116.8	-2%	119.3	115.8	-3%	115.6	-3%	118.1	-1%	119.3	117.4	-2%	117.2	-2%
8323	MACAS MJ	118.05	118.6	118.6	121.3	2%	121.6	3%	118.6	117.6	-1%	117.4	-1%	118.6	116.6	-2%	116.3	-2%	118.6	115.5	-3%	115.2	-3%	118.1	0%	118.6	116.9	-1%	116.7	-2%
8330	MACAS 3J	118.05	118.5	118.5	121.3	2%	121.6	3%	118.5	117.5	-1%	117.3	-1%	118.5	116.5	-2%	116.2	-2%	118.5	115.4	-3%	115.2	-3%	118.1	0%	118.5	116.8	-1%	116.6	-2%
8331	MACASSA3	118.05	118.5	118.5	121.3	2%	121.6	3%	118.5	117.5	-1%	117.3	-1%	118.5	116.4	-2%	116.2	-2%	118.5	115.4	-3%	115.2	-3%	118.1	0%	118.5	116.8	-1%	116.5	-2%
8339	MAC MILL	118.05	118.6	118.6	121.3	2%	121.6	3%	118.6	117.6	-1%	117.4	-1%	118.6	116.5	-2%	116.3	-2%	118.6	115.5	-3%	115.2	-3%	118.1	0%	118.6	116.9	-1%	116.7	-2%
8340	MONTEIDS	118.05	124.1	124.1	124.8	1%	124.9	1%	124.1	123.8	0%	123.7	0%	124.1	123.1	-1%	123.0	-1%	124.1						124.1	123.8	0%	123.7	0%	
8345	NMILEJD3	118.05	123.7	123.7	124.7	1%	124.9	1%	123.7	122.5	-1%	122.2	-1%	123.7				123.7	122.1	-1%	121.9	-1%	123.2	0%	123.7	122.9	-1%	122.7	-1%	
8352	GULL SJ3	118.05	119.5	119.5	121.7	2%	122.0	2%	119.5	118.5	-1%	118.2	-1%	119.5				119.5	116.1	-3%	115.9	-3%	118.3	-1%	119.5	117.7	-1%	117.5	-2%	
8353	GULL SJ2	118.05	119.2	119.2	121.4	2%	121.7	2%	119.2	118.2	-1%	118.0	-1%	119.2	117.0	-2%	116.7	-2%	119.2	115.8	-3%	115.5	-3%	118.0	-1%	119.2	117.4	-2%	117.1	-2%
8354	NPWR T1	118.05	119.5	119.5	121.6	2%	121.9	2%	119.5	118.5	-1%	118.2	-1%	119.5				119.5	116.1	-3%	115.9	-3%	118.3	-1%	119.5	117.7	-1%	117.4	-2%	
8355	NPWR T2	118.05	119.2	119.2	121.4	2%	121.7	2%	119.2	118.2	-1%	118.0	-1%	119.2	117.0	-2%	116.7	-2%	119.2	115.8	-3%	115.5	-3%	118.0	-1%	119.2	117.4	-2%	117.1	-2%
8365	PORCUPIN	118.05	126.4	126.4	126.4	0%	126.4	0%	126.4	126.3	0%	126.3	0%	126.4	126.1	0%	126.0	0%	126.4	126.2	0%	126.1	0%	126.2	0%	126.4	126.2	0%	126.2	0%
8371	RAMORE	118.05	120.7	120.7	122.2	1%	122.5	1%	120.7	119.9	-1%	119.8	-1%	120.7	119.3	-1%	119.1	-1%	120.7						120.7	118.8	-2%	118.6	-2%	
8519	NPWR T3	118.05	119.5	119.5	121.6	2%	121.9	2%	119.5	118.5	-1%	118.2	-1%	119.5				119.5	116.1	-3%	115.9	-3%	118.3	-1%	119.5	117.7	-1%	117.4	-2%	
8525	MONTA8KJ	118.05	124.1	124.1	124.8	1%	124.9	1%	124.1	123.8	0%	123.7	0%	124.1	123.1	-1%	123.0	-1%	124.1	123.5	0%	123.4	-1%	124.1	0%	124.1				
8538	NEWMONTJ	118.05	116.8	116.8	119.0	2%	119.4	2%	116.8	115.8	-1%	115.6	-1%	116.8	114.6	-2%	114.3	-2%	116.8	113.4	-3%	113.0	-3%	115.6	-1%	116.8	115.0	-2%	114.7	-2%
8554	MACA MJA	118.05	118.6	118.6	121.3	2%	121.6	3%	118.6	117.6	-1%	117.4	-1%	118.6	116.6	-2%	116.3	-2%	118.6	115.5	-3%	115.2	-3%	118.1	0%	118.6	116.9	-1%	116.7	-2%
8555	MACA 3JA	118.05	118.5	118.5	121.3	2%	121.6	3%	118.5	117.5	-1%	117.3	-1%	118.5	116.5	-2%	116.2	-2%	118.5	115.4	-3%	115.2	-3%	118.1	0%	118.5	116.8	-1%	116.6	-2%
1510	YDBUS1	13.8	13.1	13.1					13.1	13.0	-1%	13.0	-1%	13.1	13.0	-1%	13.0	-1%	13.1	13.0	-1%	13.0	-1%	13.6	4%	13.1	13.0	-1%	13.0	-1%
1511	YDBUS2	13.8	13.1	13.1					13.1	13.0	-1%	13.0	-1%	13.1	13.0	-1%	13.0	-1%	13.1	13.0	-1%	13.0	-1%	13.6	4%	13.1	13.0	-1%	13.0	-1%
1520	TR1A	13.8	13.1	13.1					13.1	13.0	-1%	13.0	-1%	13.1	13.0	-1%	13.0	-1%	13.1	13.0	-1%	13.0	-1%	13.6	4%	13.1	13.0	-1%	13.0	-1%
1521	LOAD1A	4.16	3.9	3.9					3.9	3.9	-1%	3.9	-1%	3.9	3.9	-1%	3.9	-1%	3.9	3.9	-1%	3.9	-1%	4.1	4%	3.9	3.9	-1%	3.9	-1%
1522	TR1B	13.8	13.1	13.1					13.1	13.0	-1%	13.0	-1%	13.1	13.0	-1%	13.0	-1%	13.1	13.0	-1%	13.0	-1%	13.6	4%	13.1	13.0	-1%	13.0	-1%
1523	AGMILL	4.16	4.0	4.0					4.0	3.9	-1%	3.9	-1%	4.0	3.9	-1%	3.9	-1%	4.0	3.9	-1%	3.9	-1%	4.1	4%	4.0	3.9	-1%	3.9	-1%
1524	TR2	13.8	13.1	13.1					13.1	13.0	-1%	13.0	-1%	13.1	13.0	-1%	13.0	-1%	13.1	13.0	-1%	13.0	-1%	13.6	4%	13.1	13.0	-1%	13.0	-1%
1525	LOAD2	4.16	3.9	3.9					3.9	3.9	-1%	3.9	-1%	3.9	3.9	-1%	3.9	-1%	3.9	3.9	-1%	3.9	-1%	4.1	4%	3.9	3.9	-1%	3.9	-1%
8607	MCDERTR2	4.16	4.0	4.0	4.1	2%	4.1	2%	4.0	4.0	-1%	3.9	-1%	4.0	3.9	-2%	3.9	-2%	4.0											

Appendix C: Results Summary Table

Bus #	Bus Name	B8 (D3K w/Kirk Gen) (note 1)				C				E (8MVA capacitor switching)			F1		F2		F3		F4				
		Nominal kV	Pre-Cont w/Cap		Post-Contingency				(Steady State Motor Starting)			Base = Case B6, A9K out, no DVAR			(Kirk Volt Base, YD=0MW)		(Kirk Volt Base, YD=17MW)		(Kirk Volt Max, YD=0MW)		(Kirk Volt Max, YD=17MW)		
			kV	YD Cap kV	Change %	Pre-ULTC kV	Change %	Post-ULTC kV	Change %	Base kV	MtrStt kV	Change %	Base kV	Add Cap kV	Change %	two SVC kV	three SVC kV	two SVC kV	three SVC kV	two SVC kV	three SVC kV	two SVC kV	three SVC kV
8000	HANMER	500	532.1	532.2	0%	532.4	0%	532.5	0%	533.5	533.6	0.0%	532.6	532.9	0%	533.9	533.8	533.9	533.9	532.3	532.3	532.9	532.9
8001	PINARD	500	543.4	543.5	0%	543.7	0%	543.9	0%	545.0	545.1	0.0%	544.4	544.6	0%	545.3	545.2	245.3	245.3	542.9	542.8	543.5	543.4
8002	PORCUPIN	500	535.2	535.3	0%	535.7	0%	535.9	0%	537.7	537.7	0.0%	536.6	536.9	0%	538.1	538.0	538.1	538.1	534.4	534.3	535.3	535.3
8101	ANSONVIL	220	242.7	242.9	0%	242.9	0%	242.9	0%	243.0	243.0	0.0%	242.4	242.6	0%	243.5	242.4	243.4	243.4	242.6	242.6	242.8	242.8
8103	DYMOND	220	245.6	245.9	0%	245.5	0%	245.6	0%	248.6	248.7	0.0%	244.4	245.7	1%	250.3	250.1	249.6	249.6	247.5	247.4	248.2	248.1
8104	HANMER	220	245.8	245.8	0%	246.0	0%	246.1	0%	246.6	246.6	0.0%	246.1	246.2	0%	246.7	246.7	246.7	246.7	246.0	245.9	246.2	246.2
8109	PINARD	220	248.0	248.0	0%	248.1	0%	248.1	0%	248.5	248.5	0.0%	248.3	248.3	0%	248.6	248.6	248.6	248.6	247.8	247.8	248.0	248.0
8110	PORCUPIN	220	241.6	241.7	0%	241.8	0%	241.9	0%	242.6	242.6	0.0%	242.0	242.2	0%	242.9	242.8	242.9	242.9	241.3	241.3	241.6	241.6
1500	MATAJCT	118.05	120.6	123.1	2%	119.2	-1%	118.9	-1%	115.4	115.5	0.1%	107.7	111.5	4%	122.8	122.0	118.4	118.4	125.3	124.7	123.4	122.8
1501	YOUNGDAV	118.05	120.1	122.8	2%	118.6	-1%	118.3	-1%	114.9	115.0	0.1%	107.1	111.1	4%	122.9	122.0	118.1	118.1	125.1	124.5	123.0	122.3
1502	YDTR1	118.05	120.1	122.8	2%	118.6	-1%	118.3	-1%	114.9	115.0	0.1%	107.1	111.1	4%	122.9	122.0	118.1	118.1	125.1	124.5	123.0	122.3
1503	YDTR2	118.05	120.1	122.8	2%	118.6	-1%	118.3	-1%	114.9	115.0	0.1%	107.1	111.1	4%	122.9	122.0	118.1	118.1	125.1	124.5	123.0	122.3
8220	NOTRE DV	118.05	124.6	125.1	0%					120.3	120.5	0.1%	114.3	116.1	2%	122.9	122.6	121.8	121.8	125.8	125.7	126.0	125.9
8225	ANSONVIL	118.05	124.6	124.8	0%	124.6	0%	124.6	0%	124.5	124.5	0.1%	123.7	124.1	0%	125.2	125.1	125.0	125.0	124.5	124.5	124.8	124.7
8229	MCDERMOT	118.05	122.8	123.4	0%	121.4	-1%	121.2	-1%	116.9	117.0	0.1%	110.0	112.0	2%	119.9	119.5	118.5	118.5	125.5	125.4	125.6	125.5
8234	HOLLOWAY	118.05	122.8	123.3	0%	121.3	-1%	121.1	-1%	116.8	117.0	0.1%	109.9	112.0	2%	119.9	119.5	118.5	118.5	125.5	125.4	125.6	125.5
8251	DANE J	118.05	124.6	125.1	0%					120.3	120.5	0.1%	114.3	116.1	2%	122.9	122.6	121.8	121.8	125.8	125.7	126.0	125.9
8258	DYMOND	118.05	122.4	122.6	0%	122.7	0%	122.8	0%	124.6	124.7	0.1%	122.1	122.9	1%	125.7	125.6	123.8	123.8	123.6	123.5	124.0	123.9
8286	GULL NJ2	118.05	125.0	125.6	0%	123.6	-1%	123.4	-1%	119.3	119.5	0.1%	112.6	114.6	2%	122.3	121.9	120.9	120.9	126.5	126.4	126.6	126.5
8321	KIRKLD60	118.05	125.0	125.6	0%	123.5	-1%	123.3	-1%	119.3	119.5	0.1%	112.6	114.6	2%	122.3	121.9	121.0	121.0	126.5	126.3	126.6	126.4
8323	MACAS MJ	118.05	124.4	125.2	1%	122.9	-1%	122.7	-1%	118.7	118.9	0.2%	111.9	114.2	2%	122.2	121.7	120.6	120.6	126.2	126.0	126.2	126.0
8330	MACAS 3J	118.05	124.3	125.2	1%	122.8	-1%	122.6	-1%	118.6	118.8	0.2%	111.8	114.1	2%	122.2	121.7	120.5	120.5	126.2	126.0	126.2	125.9
8331	MACASSA3	118.05	124.3	125.2	1%	122.8	-1%	122.6	-1%	118.6	118.8	0.2%	111.8	114.1	2%	122.2	121.7	120.5	120.5	126.2	126.0	126.1	125.9
8339	MAC MILL	118.05	124.4	125.2	1%	122.9	-1%	122.7	-1%	118.7	118.9	0.2%	111.9	114.2	2%	122.2	121.7	120.6	120.6	126.2	126.0	126.2	126.0
8340	MONTEIDS	118.05	124.7	124.9	0%	124.6	0%	124.6	0%	124.1	124.2	0.1%				125.1	124.9	124.7	124.7	124.7	124.6	125.0	124.9
8345	NMILEJD3	118.05	122.7	123.0	0%					123.7	123.8	0.1%	120.4	121.4	1%	125.1	124.9	124.6	124.6	123.8	123.7	124.2	124.2
8352	GULL SJ3	118.05	125.1	125.6	0%					119.6	119.7	0.1%	113.0	115.0	2%	122.4	122.0	121.1	121.1	126.4	126.3	126.5	126.4
8353	GULL SJ2	118.05	125.1	125.6	0%	123.6	-1%	123.5	-1%	119.3	119.4	0.1%	112.5	114.6	2%	122.2	121.8	120.9	120.9	126.5	126.4	126.6	126.5
8354	NPWR T1	118.05	125.3	125.8	0%					119.5	119.7	0.1%	113.0	114.9	2%	122.4	122.0	121.1	121.1	126.5	126.4	126.6	126.5
8355	NPWR T2	118.05	125.2	125.7	0%	123.8	-1%	123.6	-1%	119.3	119.4	0.1%	112.5	114.5	2%	122.2	121.8	120.9	120.9	126.6	126.4	126.7	126.5
8365	PORCUPIN	118.05	126.1	126.1	0%	126.3	0%	126.3	0%	126.3	126.3	0.0%	126.0	126.1	0%	126.5	126.4	126.5	126.5	126.4	126.3	126.0	126.0
8371	RAMORE	118.05	124.7	125.1	0%	123.8	-1%	123.6	-1%	120.8	120.8	0.1%				122.8	122.5	121.8	121.8	125.8	125.7	125.9	125.8
8519	NPWR T3	118.05	125.3	125.8	0%					119.5	119.7	0.1%	113.0	114.9	2%	122.4	122.0	121.1	121.1	126.5	126.4	126.7	126.5
8525	MONTA8KJ	118.05	124.8	125.0	0%	124.7	0%	124.6	0%	124.1	124.2	0.1%	122.6	123.2	0%	125.1	124.9	124.7	124.7	124.8	124.7	125.0	125.0
8538	NEWMONTJ	118.05	122.8	123.4	0%	121.4	-1%	121.2	-1%	116.9	117.0	0.1%	110.0	112.0	2%	119.9	119.5	118.5	118.5	125.5	125.4	125.6	125.5
8554	MACA MJA	118.05	124.4	125.2	1%	122.9	-1%	122.7	-1%	118.7	118.9	0.2%	111.9	114.2	2%	122.2	121.7	120.6	120.6	126.2	126.0	126.2	126.0
8555	MACA 3JA	118.05	124.3	125.2	1%	122.8	-1%	122.6	-1%	118.6	118.8	0.2%	111.8	114.1	2%	122.2	121.7	120.5	120.5	126.2	126.0	126.2	125.9
1510	YDBUS1	13.8	13.8	14.1	2%	13.6	-1%	13.6	-1%	13.2	13.2	0.3%	12.3	12.8	4%	14.1	14.0	13.6	13.6	14.4	14.3	14.1	14.0
1511	YDBUS2	13.8	13.8	14.1	2%	13.6	-1%	13.6	-1%	13.2	13.2	0.3%	12.3	12.7	4%	14.1	14.0	13.5	13.5	14.4	14.3	14.1	14.0
1520	TR1A	13.8	13.8	14.1	2%	13.6	-1%	13.6	-1%	13.2	13.2	0.3%	12.3	12.8	4%	14.1	14.0	13.6	13.6	14.4	14.3	14.1	14.0
1521	LOAD1A	4.16	4.2	4.2	2%	4.1	-1%	4.1	-1%	4.0	4.0	0.3%	3.7	3.8	4%	4.3	4.2	4.1	4.1	4.3	4.3	4.2	4.2
1522	TR1B	13.8	13.8	14.1	2%	13.6	-1%	13.6	-1%	13.2	13.2	0.3%	12.3	12.8	4%	14.1	14.0	13.6	13.6	14.4	14.3	14.1	14.0
1523	AGMILL	4.16	4.2	4.3	2%	4.1	-1%	4.1	-1%	4.0	4.0	0.4%	3.7	3.9	4%	4.3	4.2	4.1	4.1	4.3	4.3	4.3	4.2
1524	TR2	13.8	13.8	14.1	2%	13.6	-1%	13.6	-1%	13.2	13.2	0.1%	12.3	12.7	4%	14.1	14.0	13.5	13.5	14.3	14.3	14.1	14.0
1525	LOAD2	4.16	4.1	4.2	2%	4.1	-1%	4.1	-1%	4.0	4.0	0.1%	3.7	3.8	4%	4.3	4.2	4.1	4.1	4.4	4.3	4.2	4.2
8607	MCDERTR2	4.16	4.2	4.2	0%	4.2	-1%	4.1	-1%	4.0	4.0	0.1%	3.8	3.8	2%	4.1	4.1	4.1	4.1	4.2	4.3	4.3	4.3
8620	MCDERMOB	4.16	4.4	4.4	0%	4.3	-1%	4.4	1%	4.4	4.4	0.1%	4.2	4.3	2%	4.5	4.4	4.5	4.5	4.2	4.4	4.4	4.4
8730	MACASSA3	4.16	4.1	4.1	1%	4.1	-1%	4.1	1%	4.2	4.2	0.2%	4.1	4.1	0%	4.2	4.2	4.2	4.2	4.2	4.1	4.2	4.2
8731	MAC MILL	4.16	4.4	4.4	1%	4.3	-1%	4.4	0%	4.4	4.4	0.2%	4.3	4.4	1%	4.4	4.4	4.4	4.4	4.4	4.4	4.4	4.4
8754	MONTEI B	13.8	14.1	14.2	0%	14.1	0%	14.1	0%	14.1	14.1	0.1%				14.2	14.2	14.2	14.2	14.3	14.3	14.3	14.3
8785	RAMORE B	27.6	29.2	29.3	0%	29.0	-1%	29.1	0%	29.0	29.0	0.1%				29.5	29.4	29.3	29.3	29.4	29.4	29.5	29.4
8924	NPWRG6	13.8	14.0	14.0	0%											13.5	13.4	13.3	13.3	14.0	14.0	14.0	14.0
8926	NPWRG123	13.8	13.8	13.8	0%											13.6	13.6	13.5	13.5	13.8	13.8	13.8	13.8
8927	NPWR G45	13.8	13.8	13.8	0%	13.8	0%	13.8	0%							13.4	13.4	13.3	13.3	13.8	13.8	13.8	13.8
8980	HOLLOWY A	4.16	4.2	4.2	0%	4.1	-1%	4.1	-1%	4.0	4.0	0.1%	3.7	3.8	2%	4.1	4.1	4.0	4.0	4.3	4.3	4.3	4.3
8983	HOLLOWY B	4.16	4.2	4.2	0%	4.2	-1%	4.1	-1%	4.0	4.0												

## **APPENDIX D: TRANSIENT RESULTS GRAPHS**

### Appendix D1: Case D1 – Motor Starting

- Case D1 – Motor Data
- Case D1 – Bus Voltages
- Case D1 – SVC Operation

### Appendix D2: Case D1b – Motor Starting with Circuit A9K Out-of-Service

- Case D1b – Motor Data
- Case D1b – Bus Voltages
- Case D1b – SVC Operation

### Appendix D3: Case D1c – Motor Starting with Circuit A9K Out-of-Service and S&C DSTATCOM

- Case D1c – Motor Data
- Case D1c – Bus Voltages
- Case D1c – S&C DSTATCOM Operation

### Appendix D4: Case D2 – LLG Fault at Kirkland Lake with NP Kirkland Generation Off

- Case D2 – Motor Data
- Case D2 – Bus Voltages
- Case D2 – SVC Operation

### Appendix D5: Case D3 - LLG Fault at Kirkland Lake with NP Kirkland Generation On

- Case D3 – Motor Data
- Case D3 – Bus Voltages
- Case D3 – SVC Operation



2008-09 WINTER BASE CASE---- 6\_6B4P4D8N0LK16BK2LB4LX11SD10S  
1004BLIP,4747FABC,3019FETT,-98FN,1232CLAN,731FIO,

FILE: ... \CaseD1 \CaseD1-MS-Aug5-500ms-CSVGN1.out

THU, AUG 06 2009 17:43  
CASED1 - MOTOR DATA

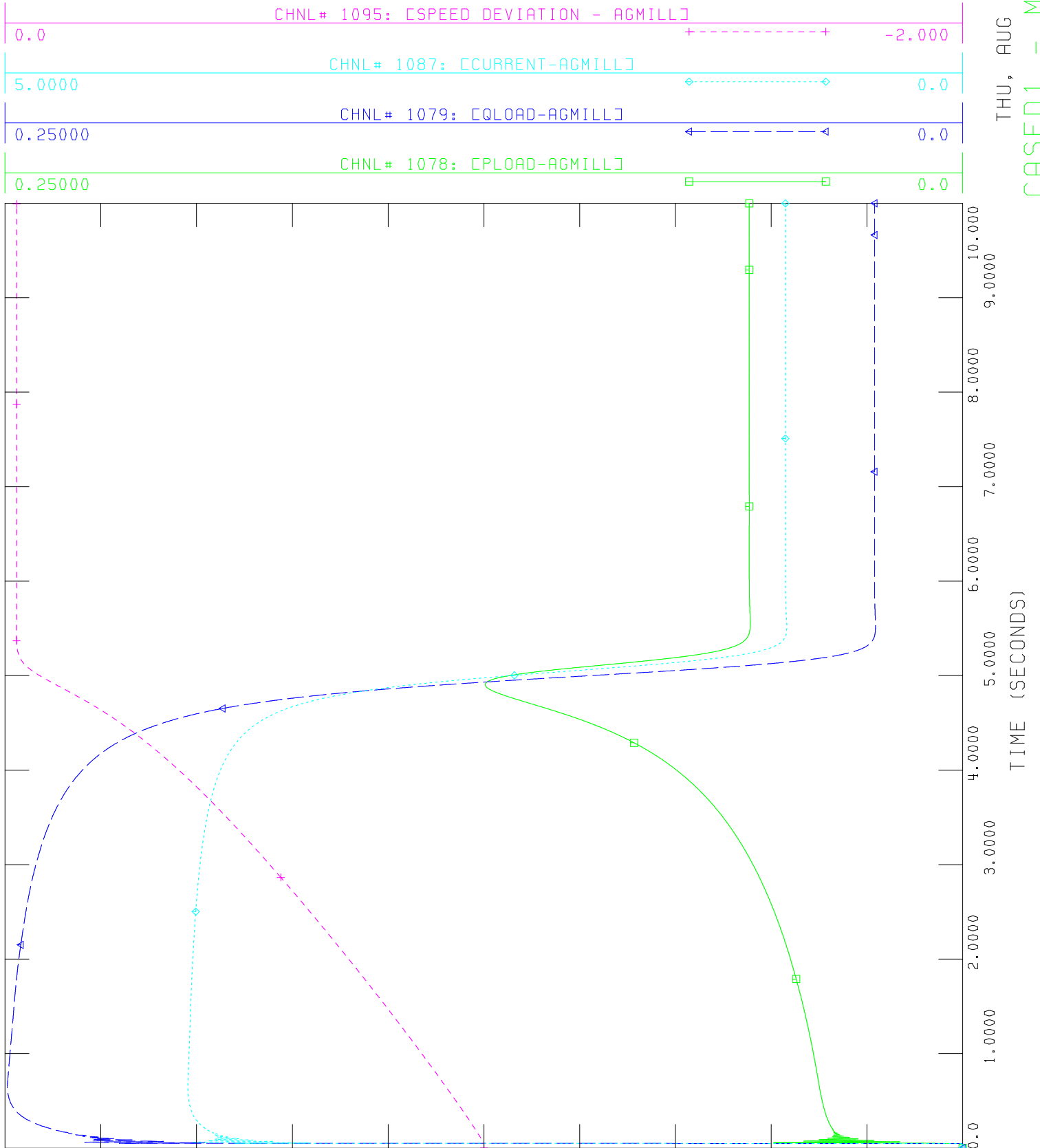



2008-09 WINTER BASE CASE---- 6\_6B4P4D8N0LK16BK2LB4LX11SD10S  
1004BLIP,4747FABC,3019FETT,-98FN,1232CLAN,731FIO,

FILE: ...\\CaseD1\\CaseD1-MS-Aug5-500ms-CSVGN1.out

THU, AUG 06 2009 17:45  
CASED1 - BUS VOLTAGES

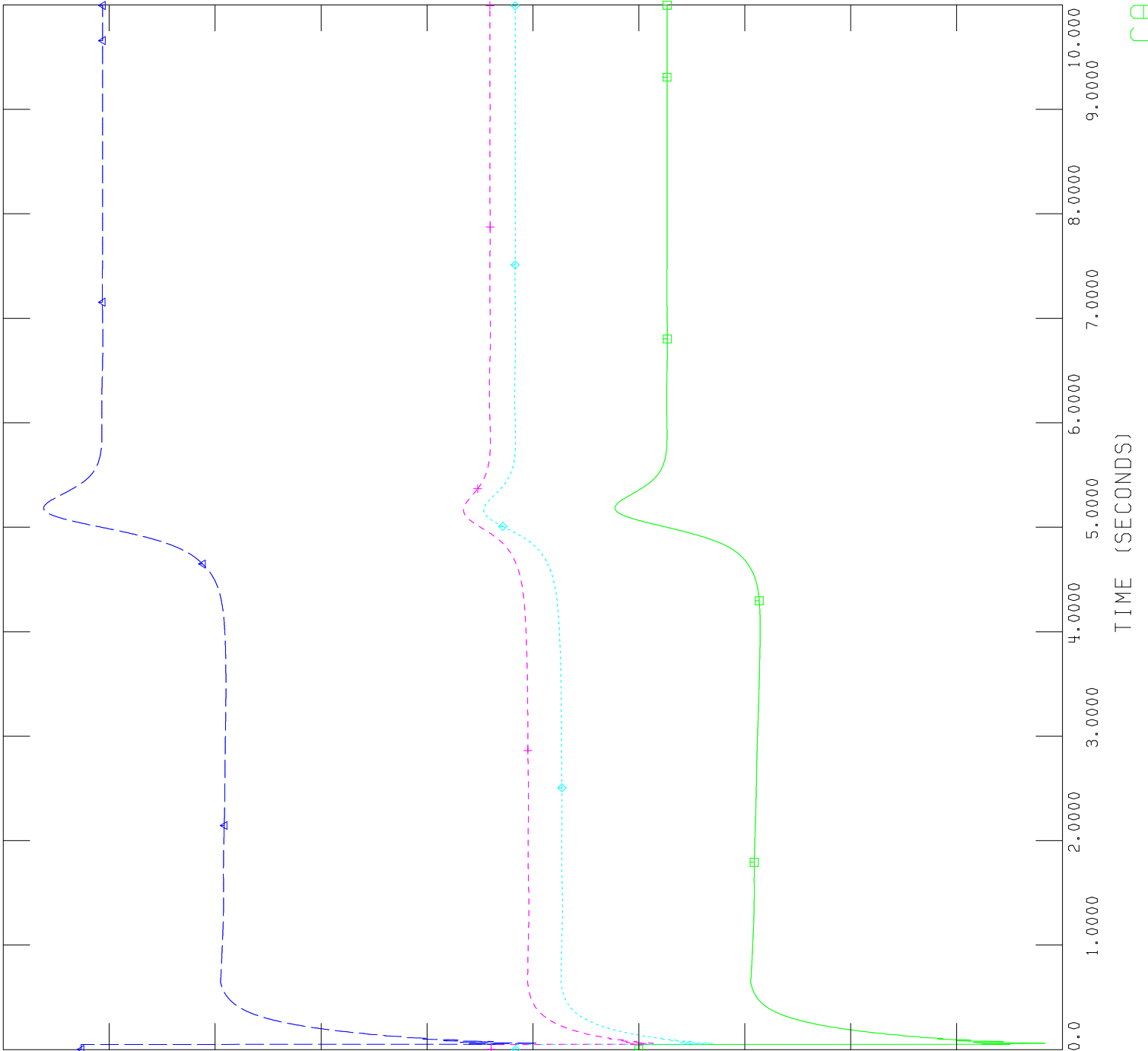
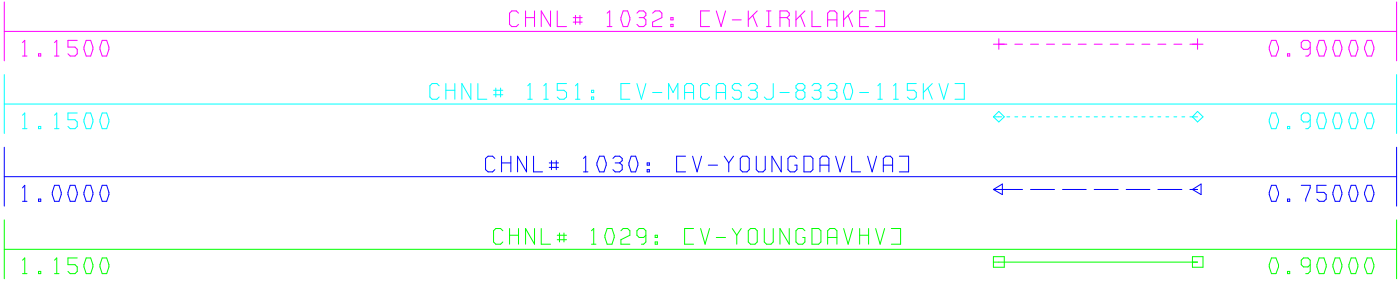

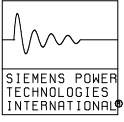

2008-09 WINTER BASE CASE---- 6\_6B4P4D8N0LK16BK2LB4LX11SD10S  
1004BLIP,4747FABC,3019FETT,-98FN,1232CLAN,731FIO,

FILE: ...\\CaseD1\\CaseD1-MS-Aug5-500ms-CSVGN1.out

THU, AUG 06 2009 17:45  
CASED1 - SVC OPERATION

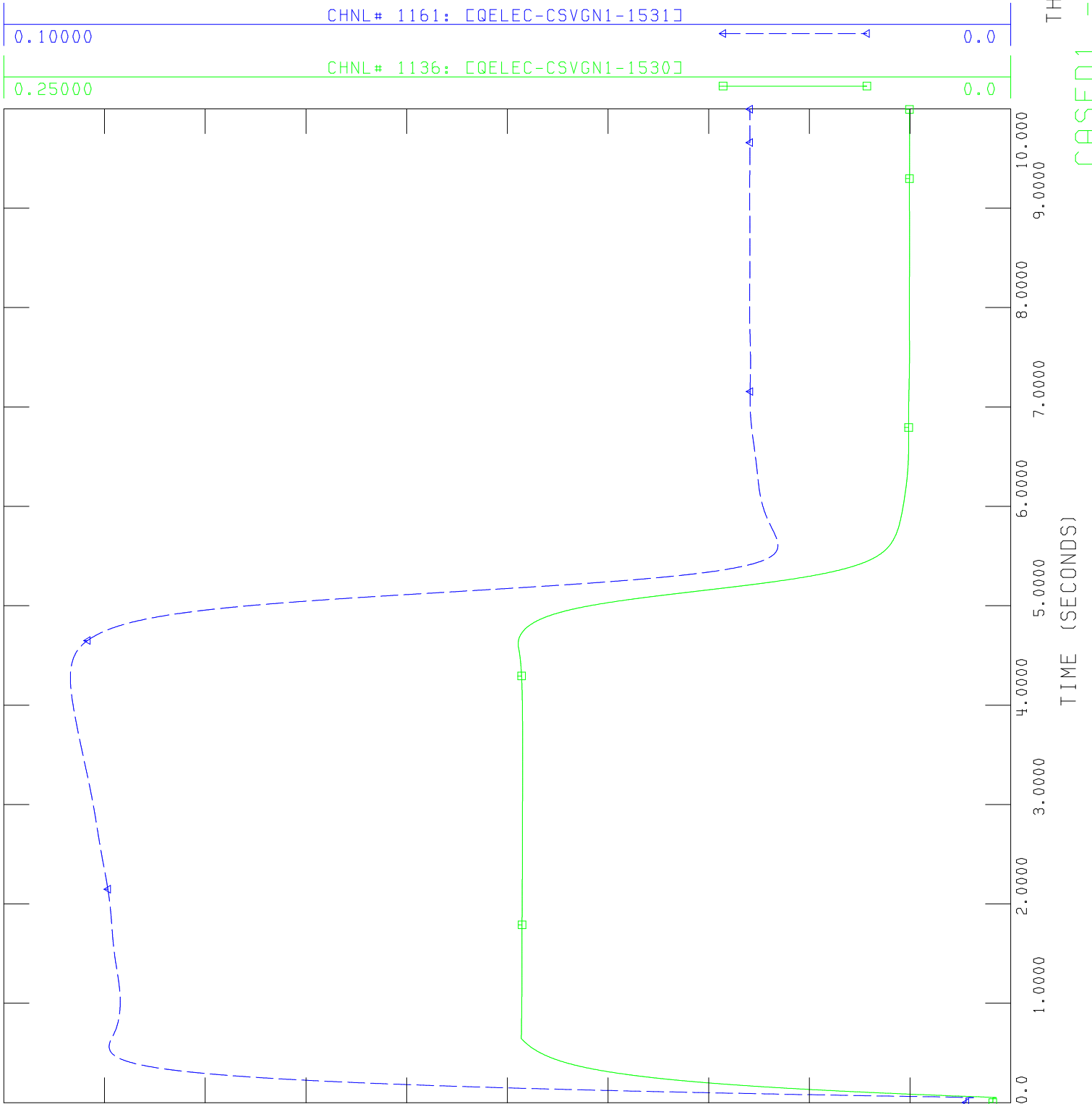



2008-09 WINTER BASE CASE---- 6\_6B4P4D8N0LK16BK2LB4LX11SD10S  
1004BLIP,4747FABC,3019FETT,-98FN,1232CLAN,731FIO,

FILE: ... \PTI\CaseD1b-MS-July28-0to13.5SVC-Vmax1.out

THU, AUG 06 2009 17:48  
CASED1B - MOTOR DATA

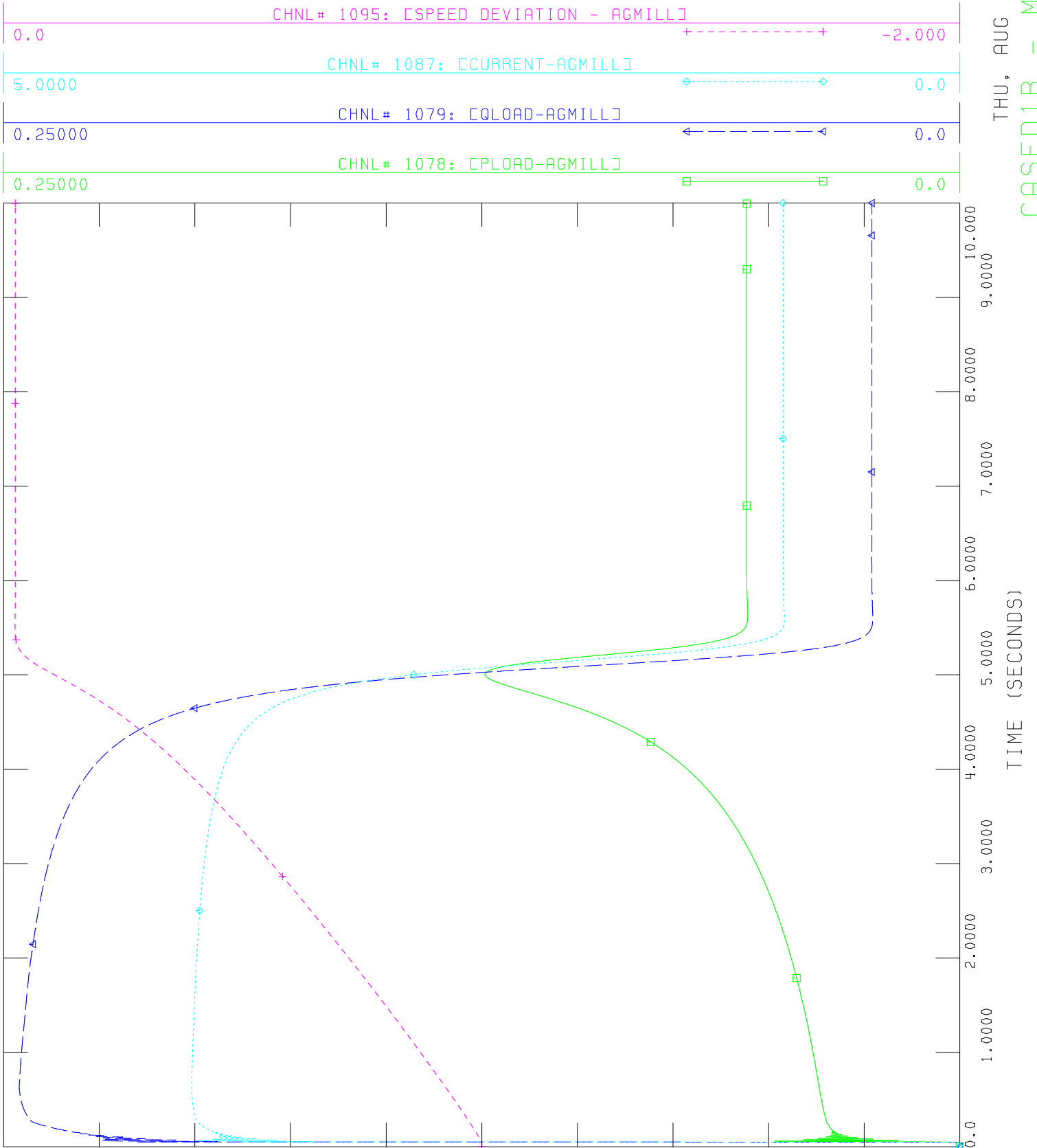



2008-09 WINTER BASE CASE---- 6\_6B4P4D8N0LK16BK2LB4LX11SD10S  
1004BLIP,4747FABC,3019FETT,-98FN,1232CLAN,731FIO,

FILE: ... \PTI\CaseD1b-MS-July28-0to13.5VC-Vmax1.out

THU, AUG 06 2009 17:48  
CASED1B - BUS VOLTAGES

Channel	Color	Max Value	Min Value
CHNL# 1032: [V-KIRKLAKE]	Magenta	1.1500	0.90000
CHNL# 1151: [V-MACAS3J-8330-115KV]	Cyan	1.1500	0.90000
CHNL# 1030: [V-YOUNGDAVLVA]	Blue	1.0000	0.75000
CHNL# 1029: [V-YOUNGDAVHV]	Green	1.0500	0.80000

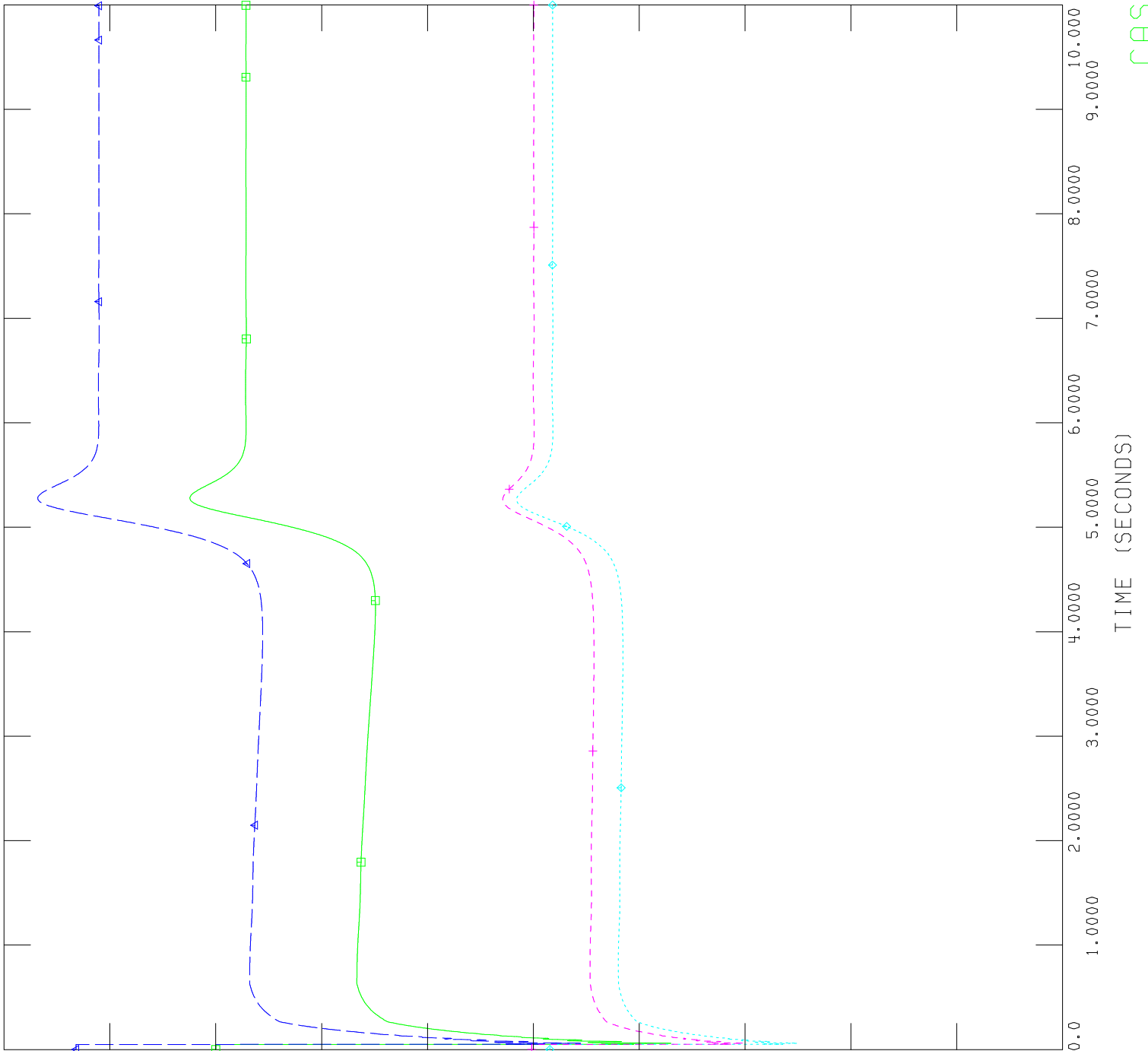



2008-09 WINTER BASE CASE---- 6\_6B4P4D8N0LK16BK2LB4LX11SD10S  
1004BLIP,4747FABC,3019FETT,-98FN,1232CLAN,731FIO,

FILE: ... \PTI \CaseD1b-MS-July28-0to13.5SVC-Vmax1.out

THU, AUG 06 2009 17:50  
CASED1B - SVC OPERATION

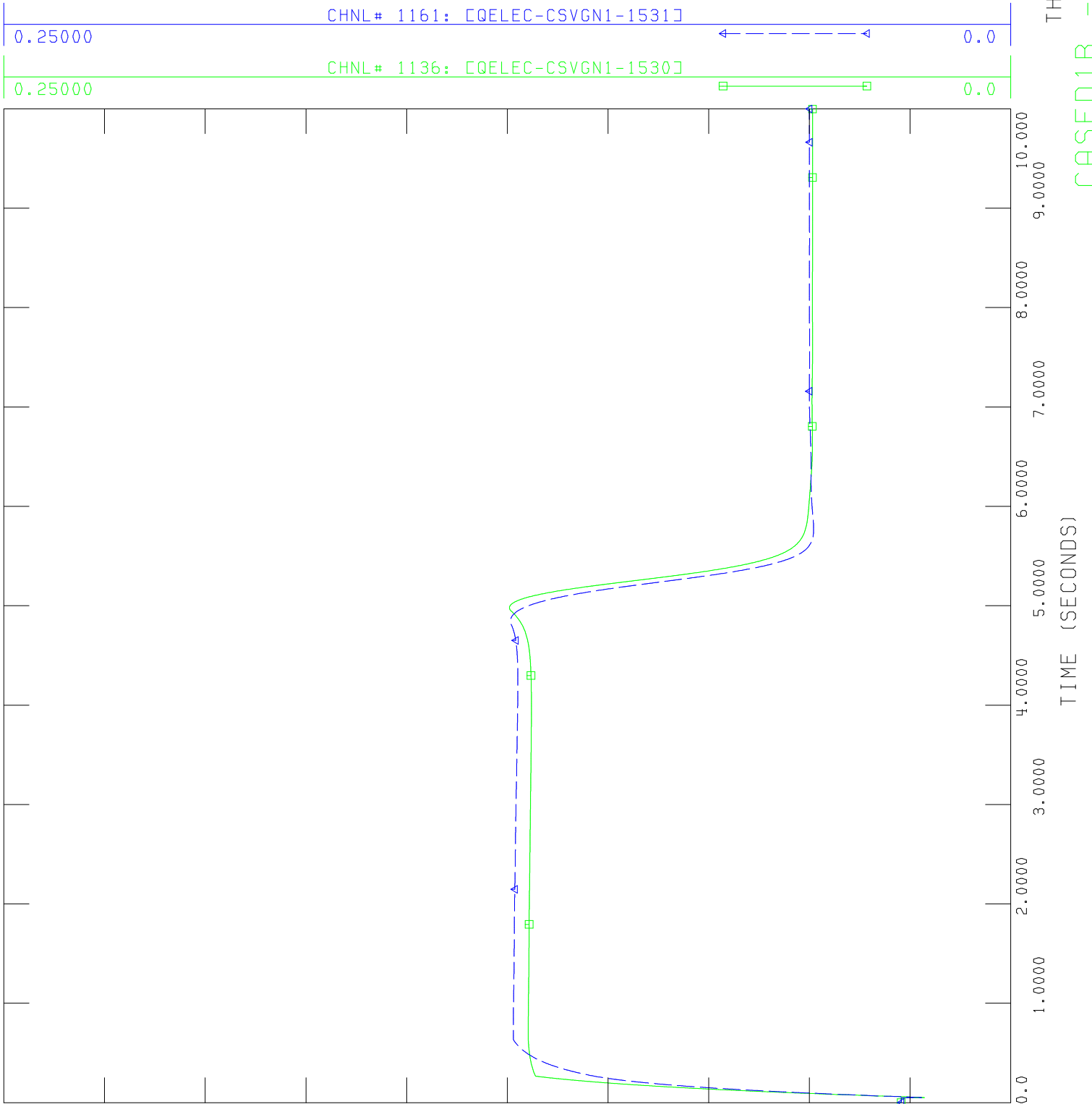



2008-09 WINTER BASE CASE---- 6\_6B4P4D8N0LK16BK2LB4LX11SD10S  
1004BLIP,4747FABC,3019FETT,-98FN,1232CLAN,731FIO,

FILE: P:\300 General Engineering\...\PTI\CaseD1b-MS-endofday.out

THU, AUG 06 2009 17:57  
CASEDIC - MOTOR DATA

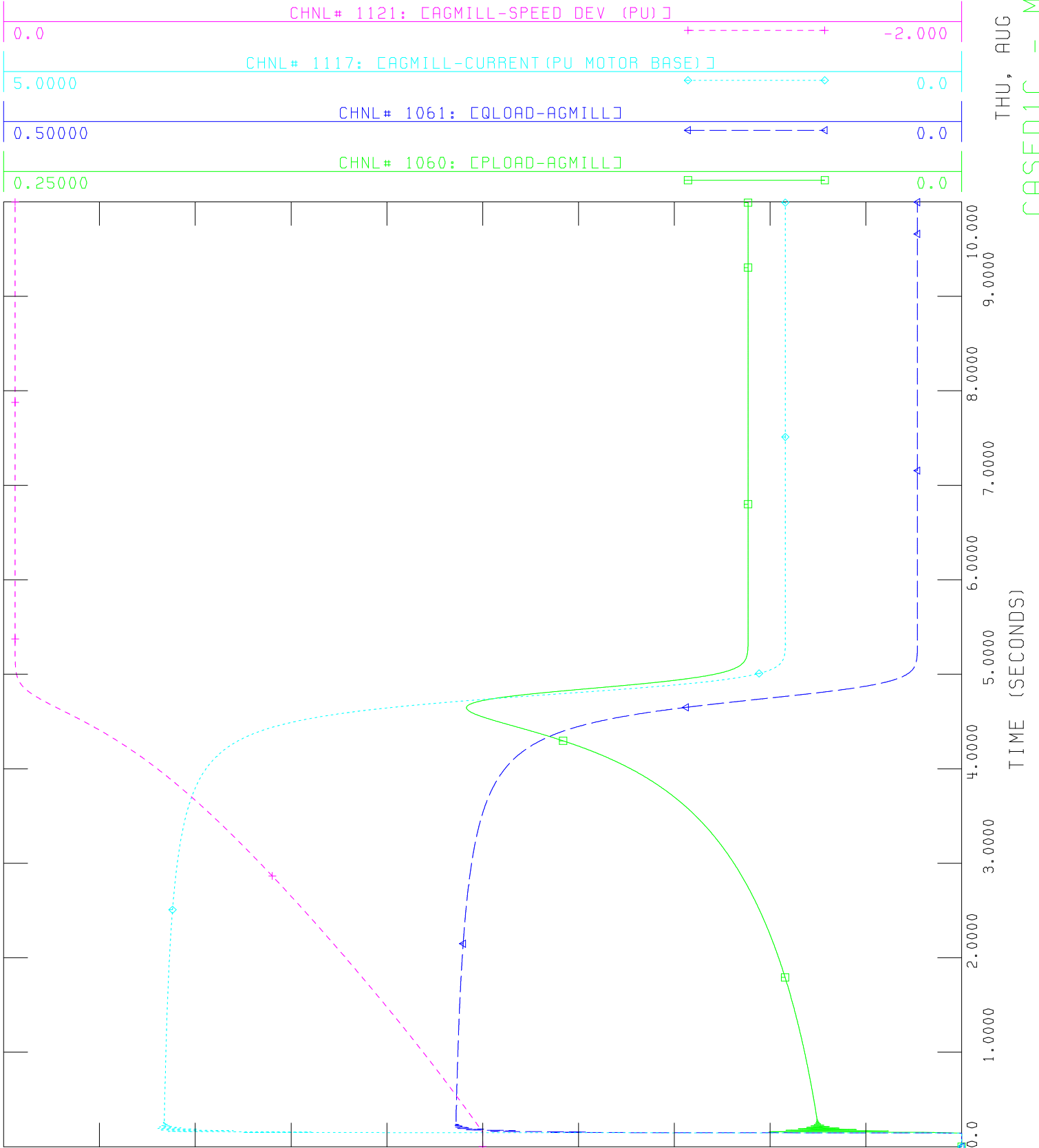



2008-09 WINTER BASE CASE---- 6\_6B4P4D8N0LK16BK2LB4LX11SD10S  
1004BLIP,4747FABC,3019FETT,-98FN,1232CLAN,731FIO,

FILE: P:\300 General Engineering\...\PTI\CaseD1b-MS-endofday.out

THU, AUG 06 2009 17:58  
CASEDIC - VOLTAGES

Channel	Value
CHNL# 1032: [V-KIRKLAKE]	0.90000
CHNL# 1101: [V-MACAS3J-8330-115KV]	0.90000
CHNL# 1030: [V-YOUNGDAVLVA]	0.75000
CHNL# 1029: [V-YOUNGDAVHV]	0.90000

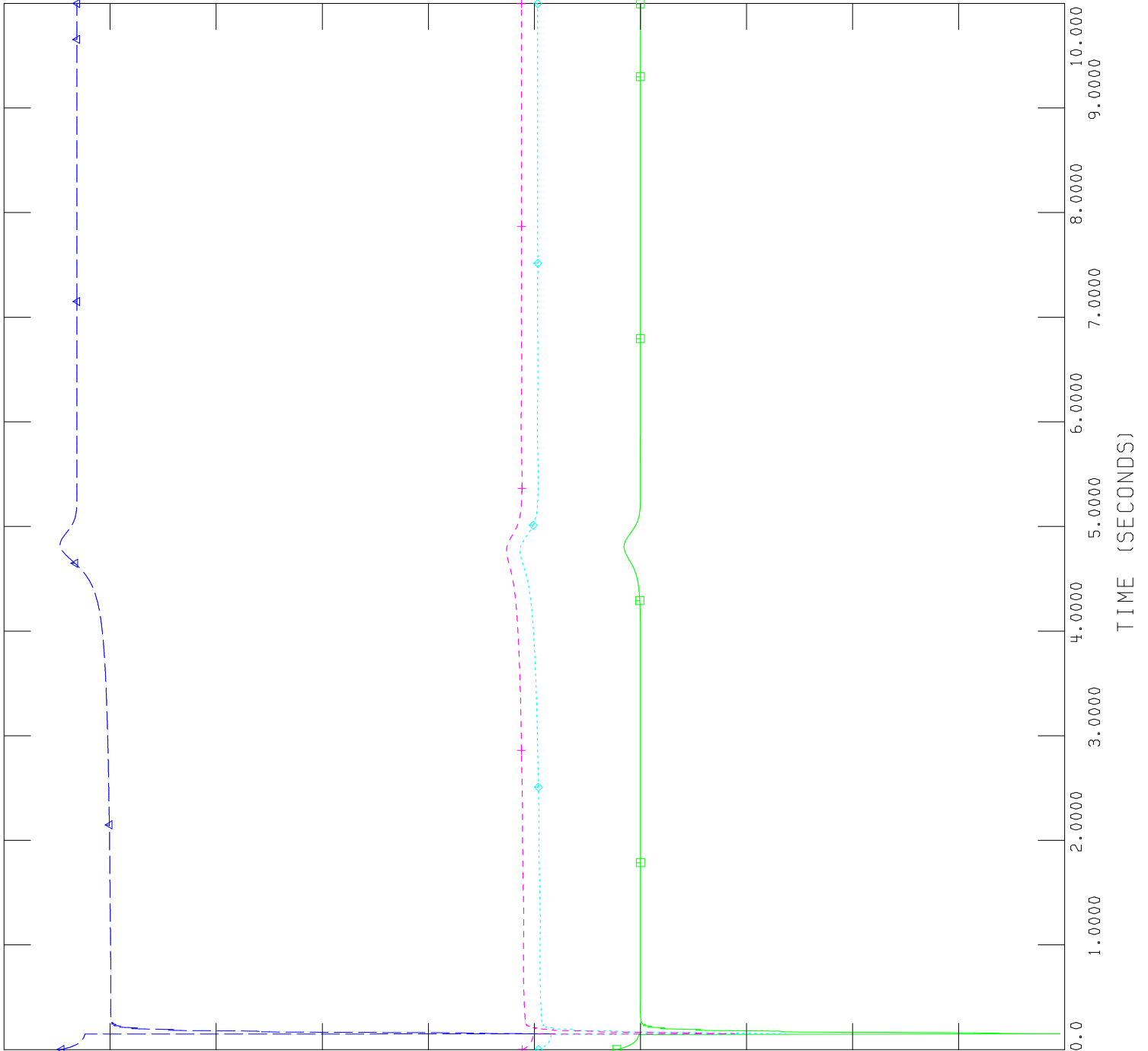



2008-09 WINTER BASE CASE---- 6\_6B4P4D8N0LK16BK2LB4LX11SD10S  
1004BLIP,4747FABC,3019FETT,-98FN,1232CLAN,731FIO,

FILE: P:\300 General Engineering\...\PTI\CaseD1b-MS-endofday.out

THU, AUG 06 2009 17:59  
CASEDIC - S&C DSTATCOM

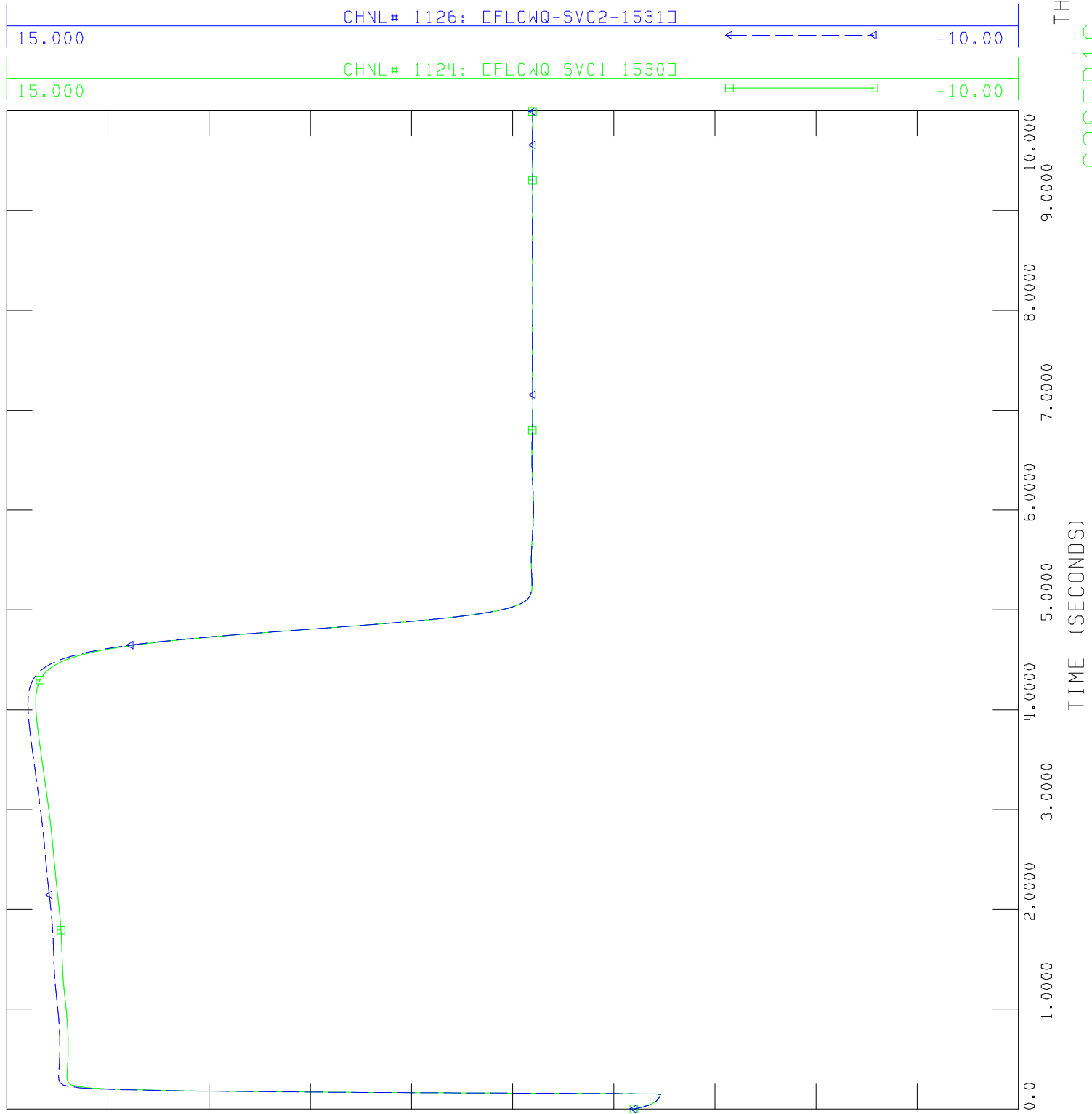



2008-09 WINTER BASE CASE---- 6\_6B4P4D8N0LK16BK2LB4LX11SD10S  
1004BLIP,4747FABC,3019FETT,-98FN,1232CLAN,731FIO,

FILE: ...\\CaseD1\\CaseD2-LLG-KirkNoGen-500ms-CSVGN1model.out

FRI, AUG 07 2009 8:40  
CASED2 - MOTOR DATA

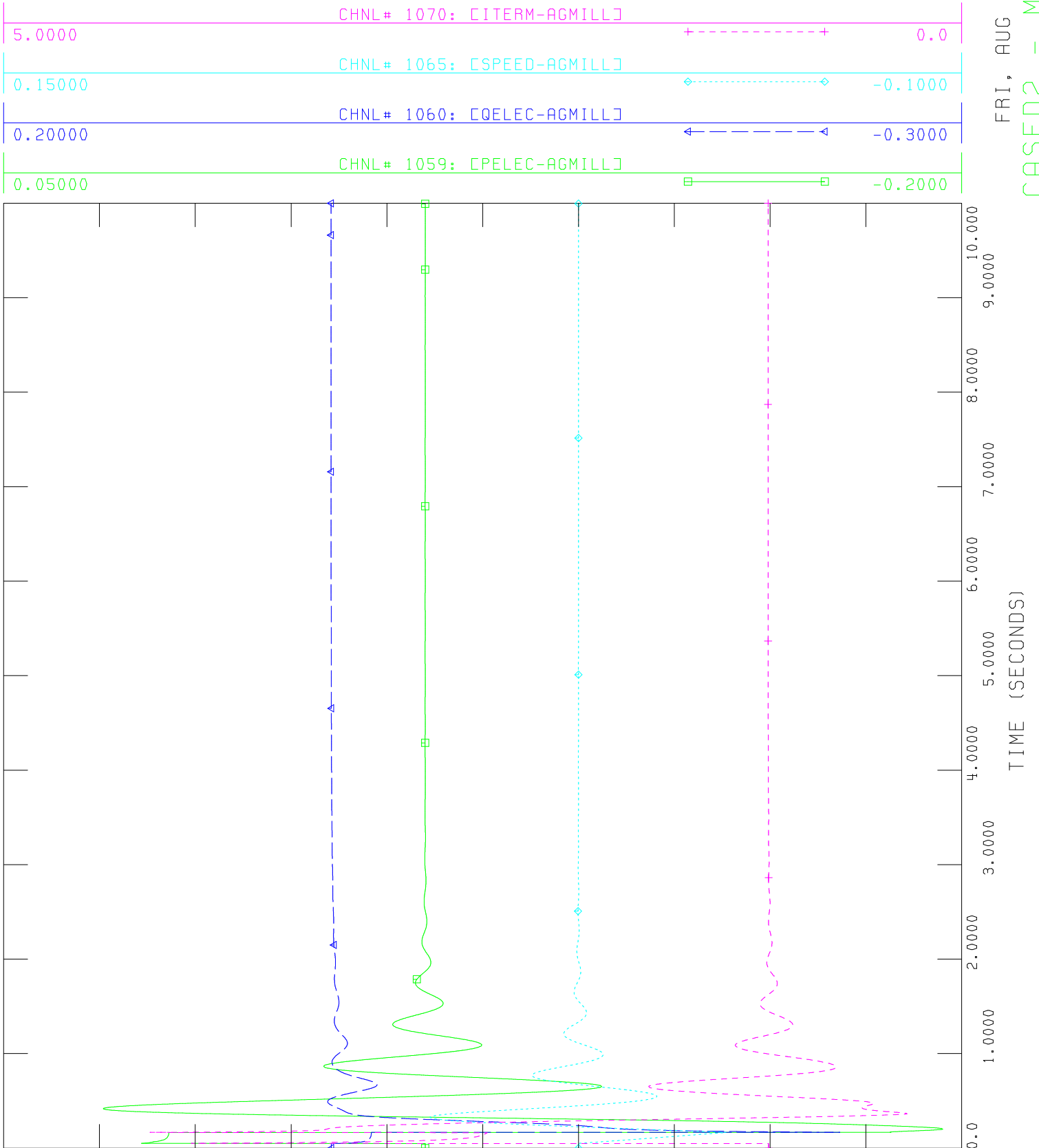



2008-09 WINTER BASE CASE---- 6\_6B4P4D8N0LK16BK2LB4LX11SD10S  
1004BLIP,4747FABC,3019FETT,-98FN,1232CLAN,731FIO,

FILE: ...\\CaseD1\\CaseD2-LLG-KirkNoGen-500ms-CSVG1model.out

FRI, AUG 07 2009 8:41  
CASED2 - BUS VOLTAGES

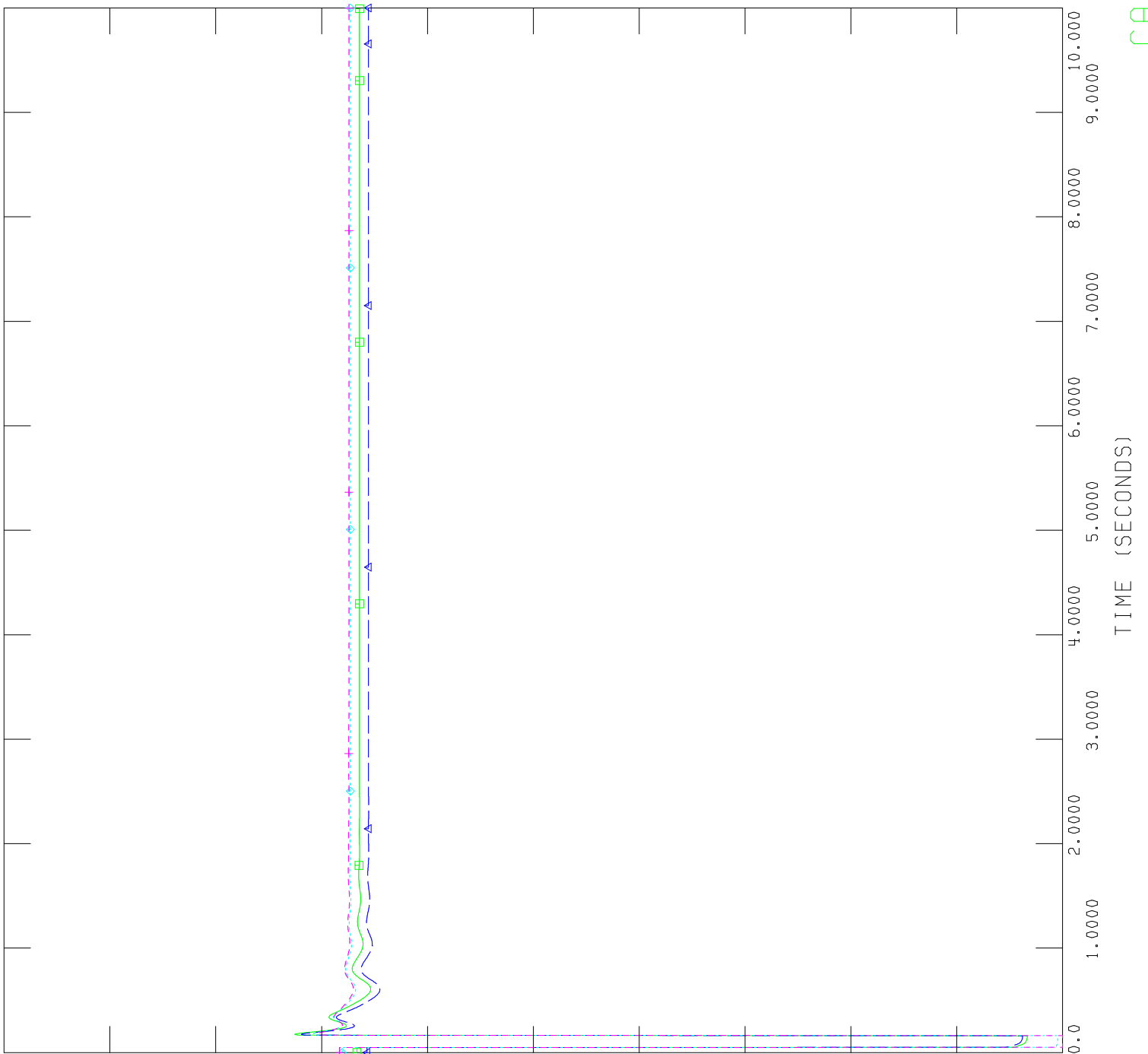
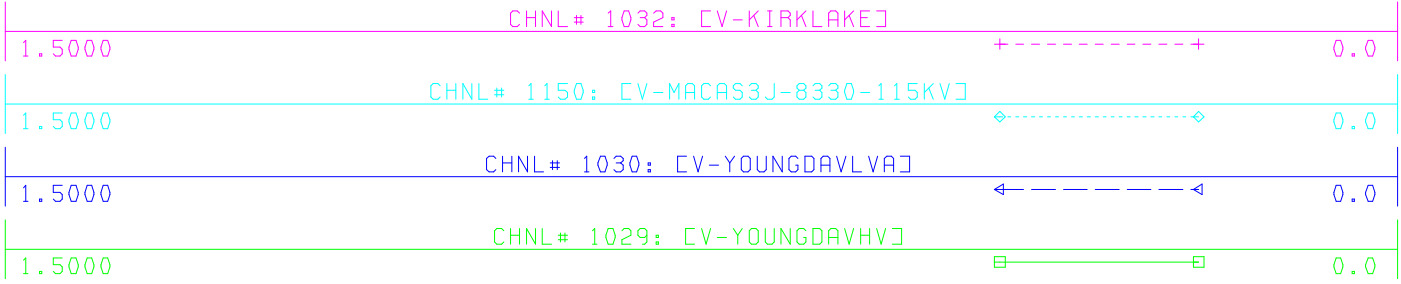



2008-09 WINTER BASE CASE---- 6\_6B4P4D8N0LK16BK2LB4LX11SD10S  
1004BLIP,4747FABC,3019FETT,-98FN,1232CLAN,731FIO,

FILE: ...\\CaseD1\\CaseD2-LLG-KirkNoGen-500ms-CSVG1model.out

FRI, AUG 07 2009 8:43  
CASED2 - SVC OPERATION

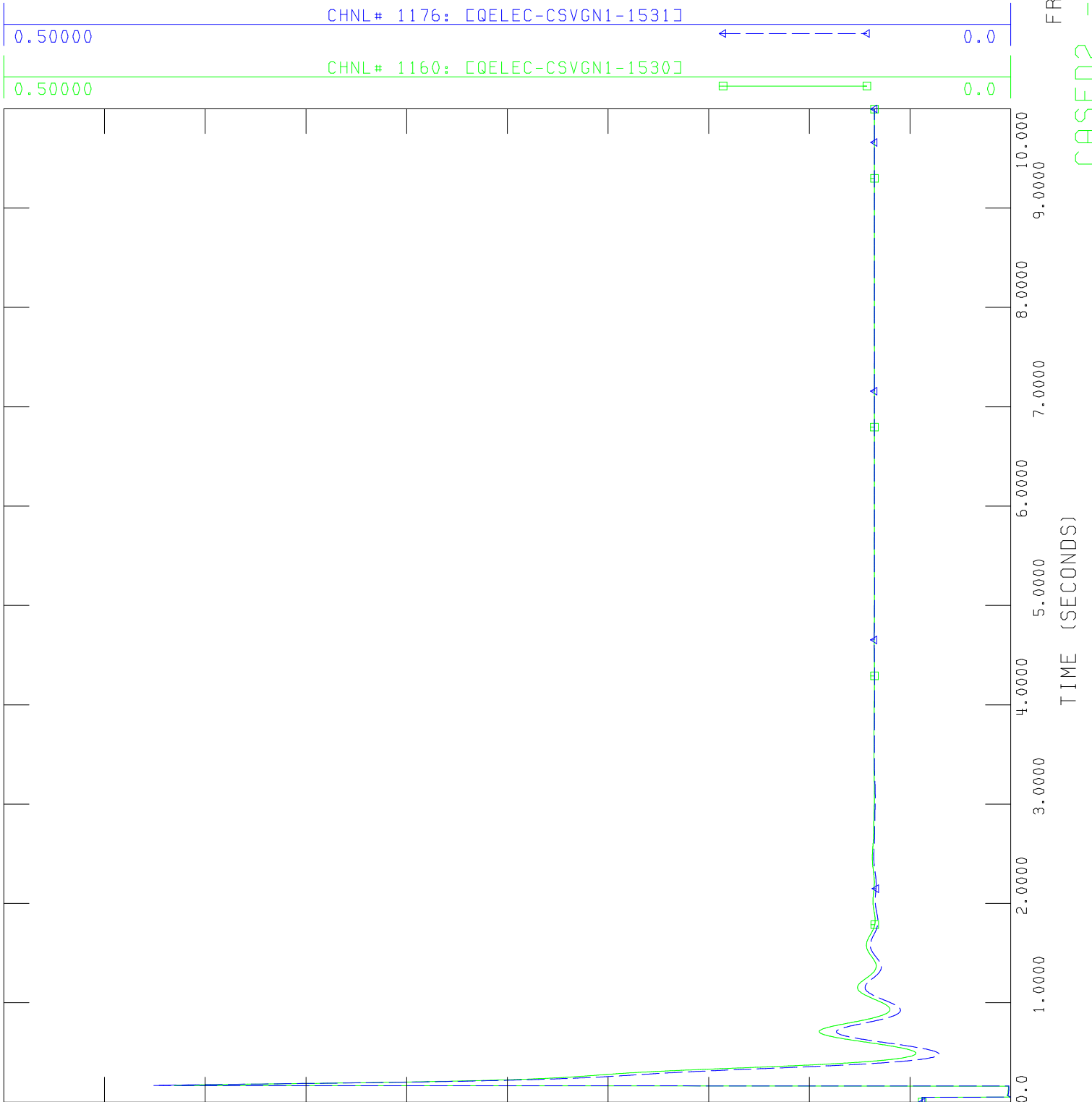



2008-09 WINTER BASE CASE---- 6\_6B4P4D8N0LK16BK2LB4LX11SD10S  
1004BLIP,4747FABC,3019FETT,-98FN,1232CLAN,731FIO,

FILE: ... \PTI \CaseD3-Dynamic-LLGFault-withKirkGen-LoseDyT3.out

FRI, AUG 07 2009 14:03  
CASED3 - MOTOR DATA

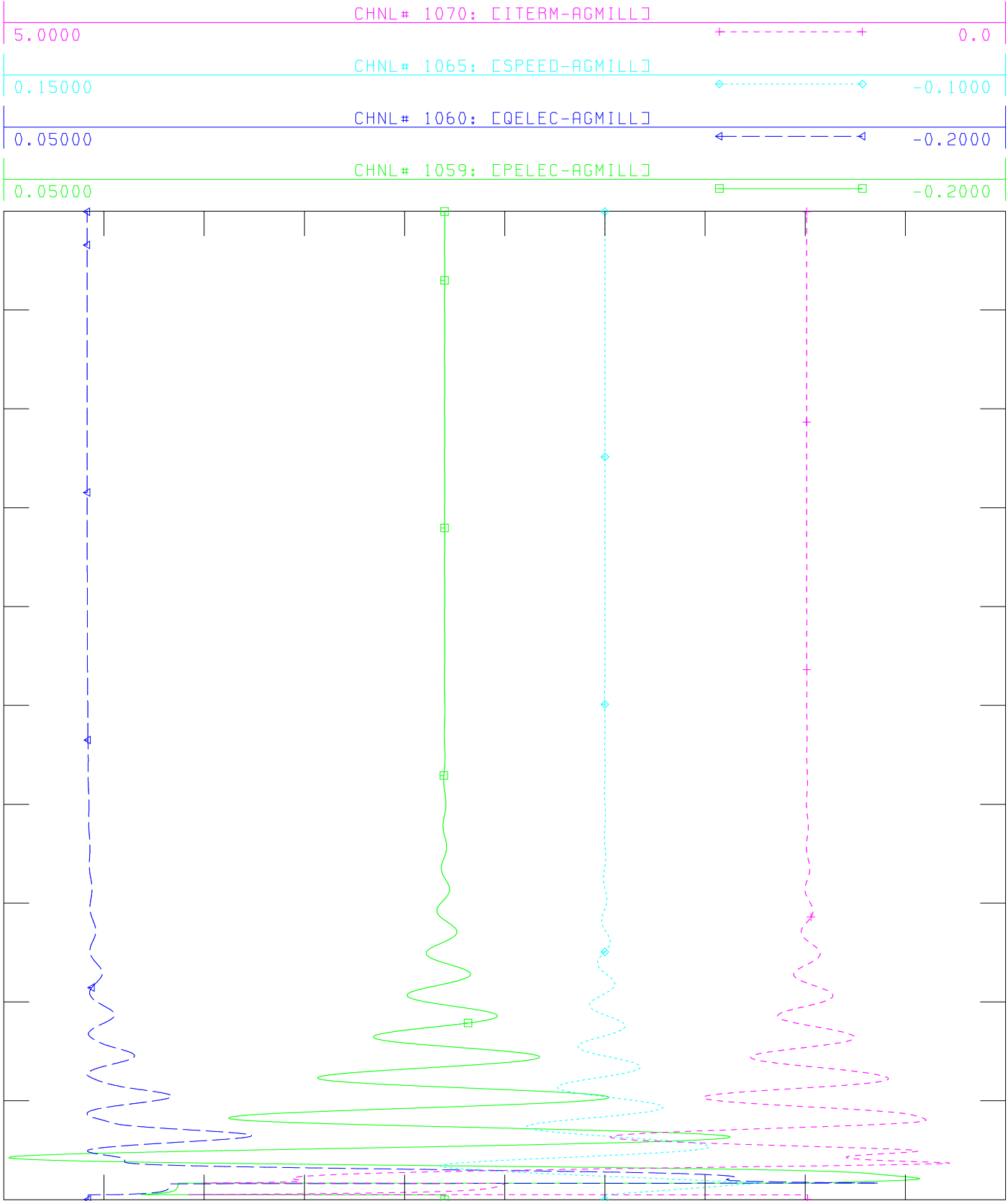



2008-09 WINTER BASE CASE---- 6\_6B4P4D8N0LK16BK2LB4LX11SD10S  
1004BLIP,4747FABC,3019FETT,-98FN,1232CLAN,731FIO,

FILE: ... \PTI \CaseD3-Dynamic-LLGFault-withKirkGen-LoseDyT3.out

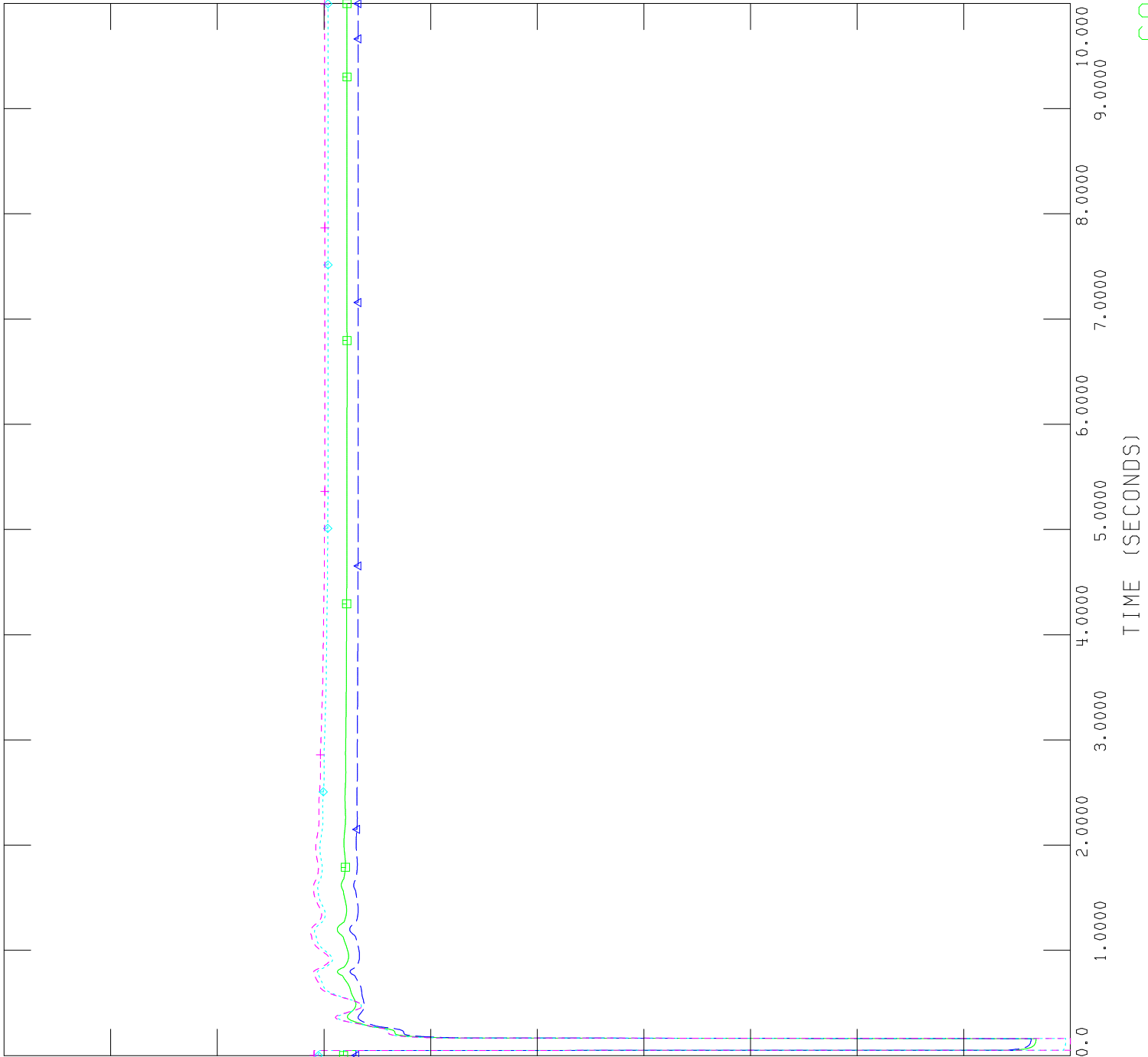
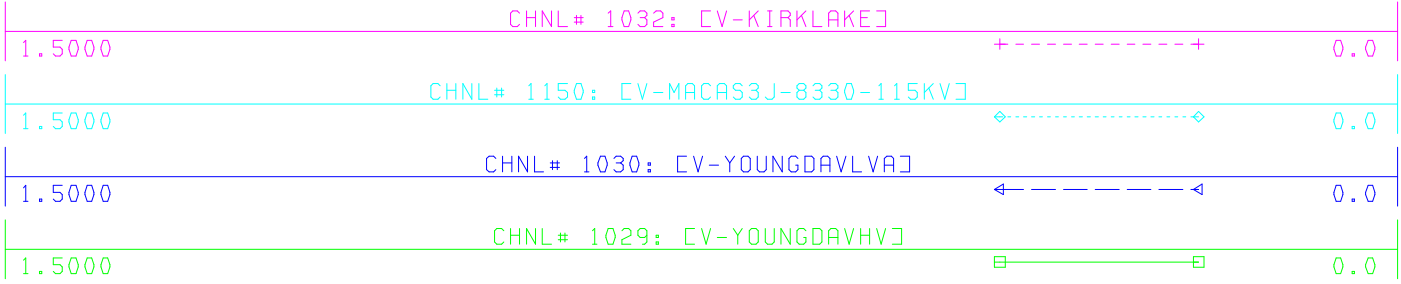

FRI, AUG 07 2009 14:04  
CASED3 - BUS VOLTAGES

