

1.0 General Description

Ontario Power Generation Inc. is planning to replace the aging Voith EHR 530 analogue electronic governors equipped to generators G3, G4, G5, G6, G8, G9 and G10 at Beck#1 GS with TEPID digital governors made by North American Phoenix Energy Services. The project is scheduled as follows:

2009 – Units G5 and G8

2010 – Units G4 and G9

2011 – Unit G6

2012 – Unit G10

2013 – Unit G3

All proposed governors are virtually identical.

2.0 Models and Parameters

2.1 Governor model

The appropriate simulation model for the proposed governors is the WECC Double-Derivative Hydro Governor (WSHYDD). The block diagram of this governor model is shown in Figure 1. The parameters of the governor model are shown in Table 1.

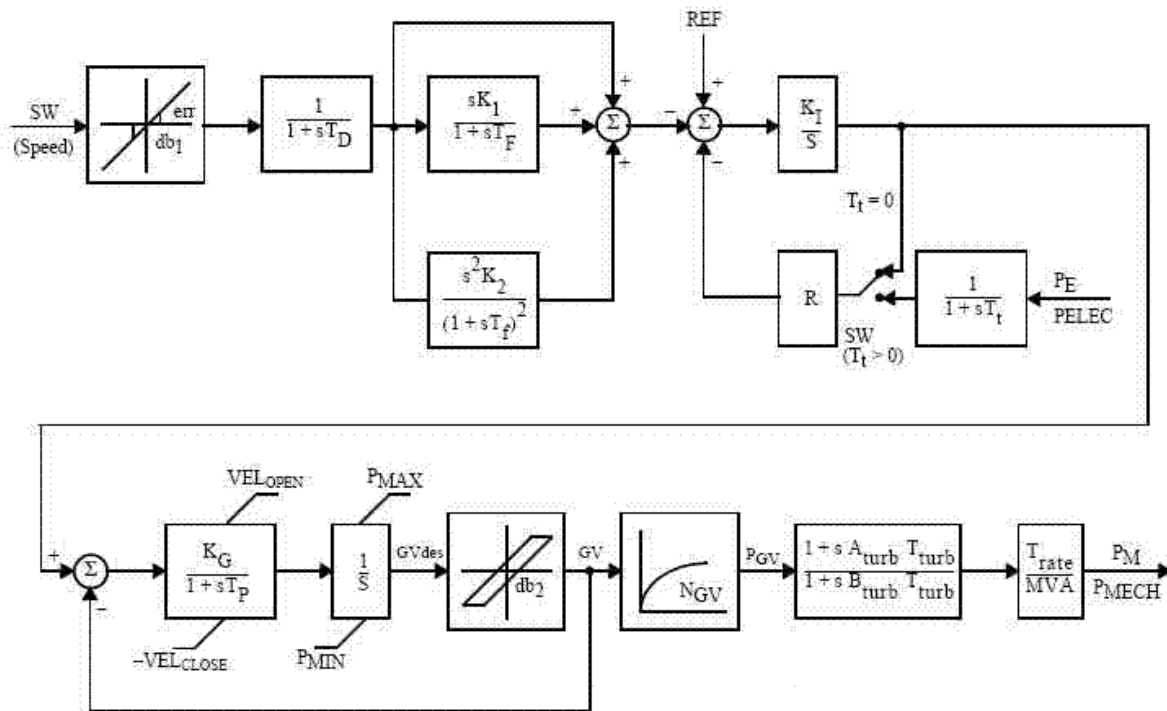

Figure 1: Block Diagram of WSHYDD governor

Description	CON	Parameter	Value	Units
Intentional deadband width	J	db1	0	Hz
Intentional deadband hysteresis	J+1	err	0	Hz
Input filter time constant	J+2	Td	0.1	sec
Single derivative gain	J+3	K1	6.3	pu
Washout time constant	J+4	Tf	0.1	sec
Double derivative gain	J+5	K2	1.9	pu
Integral gain	J+6	Ki	0.25	pu
Droop	J+7	R	0.04	
Power feedback time constant	J+8	Tt	1	sec
Gate servo gain	J+9	Kg	1.4	pu
Gate servo time constant	J+10	Tp	0.2	sec
Maximum gate opening velocity	J+11	Velopen	0.07	pu/sec
Maximum gate closing velocity	J+12	Velclose	0.07	pu/sec
Maximum gate opening	J+13	Pmax	1	pu of Trate
Minimum gate opening	J+14	Pmin	0	pu of Trate
Unintentional deadband	J+15	db2	0	MW
Non-linear gain point 1	J+16	GV1	0.1	pu - gv
Non-linear gain point 1	J+17	Pgv1	0	pu – power
Non-linear gain point 2	J+18	GV2	0.6	pu - gv
Non-linear gain point 2	J+19	Pgv2	0.7	pu - power
Non-linear gain point 3	J+20	GV3	0.7	pu - gv
Non-linear gain point 3	J+21	Pgv3	0.82	pu - power
Non-linear gain point 4	J+22	GV4	0.8	pu - gv
Non-linear gain point 4	J+23	Pgv4	0.9	pu - power
Non-linear gain point 5	J+24	GV5	0.9	pu - gv
Non-linear gain point 5	J+25	Pgv5	0.95	pu – power
Turbine numerator multiplier	J+26	Aturb	-1	
Turbine denominator multiplier	J+27	Bturb (>0)	0.5	
Turbine time constant	J+28	Trub (>0)	0.9	sec
Turbine MCR	J+29	Trate	61.6	MW

Table 1: WSHYDD Model Parameters

3.0 Assessment

Ontario Power Generation Inc. is planning to replace the aging HER 530 analogue electronic governors equipped to generators G3, G4, G5, G6, G8, G9 and G10 at Beck#1 GS with TEPID digital governors made by North American Hydro.

3.1 Governor Test

Transient simulation was performed to determine the speed governor droop which is required to be between 3% and 7%. It was determined that the speed governor droop of the proposed governors is within this range:

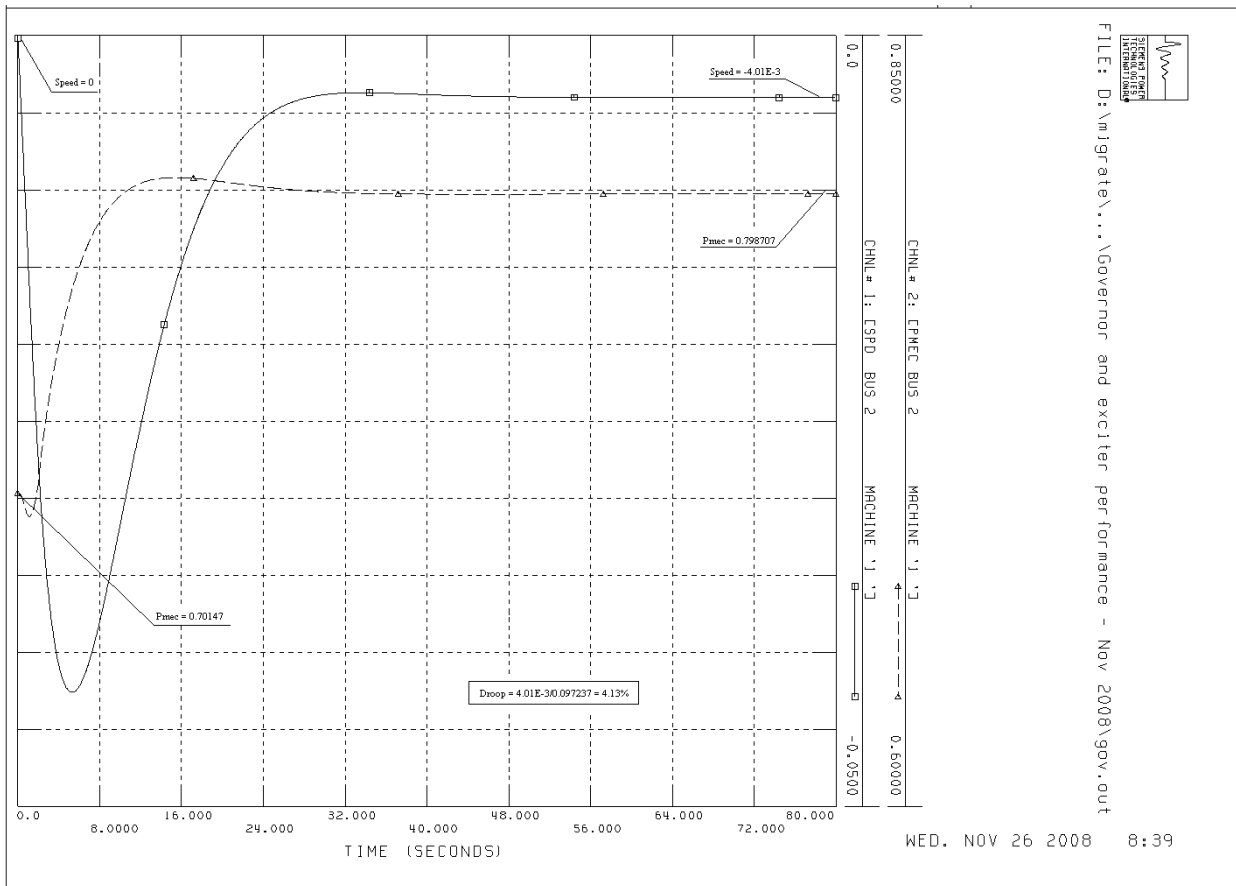

Figure 2: Governor test results for Beck#1 proposed governors

The hydraulic governor droop of the model used in this study is 4.13 % which is within the required range.

3.2 Contingency Analysis

Transient stability analysis was performed for a fault close to the Beck#1 60 Hz 115 kV bus on the Q4N circuit with the normal clearing time of 244 msec.

The mechanical power of generators G3, G4, G5, G6, G8, G9 and G10 was monitored to assess the response of the governor. The following figures are showing the results:

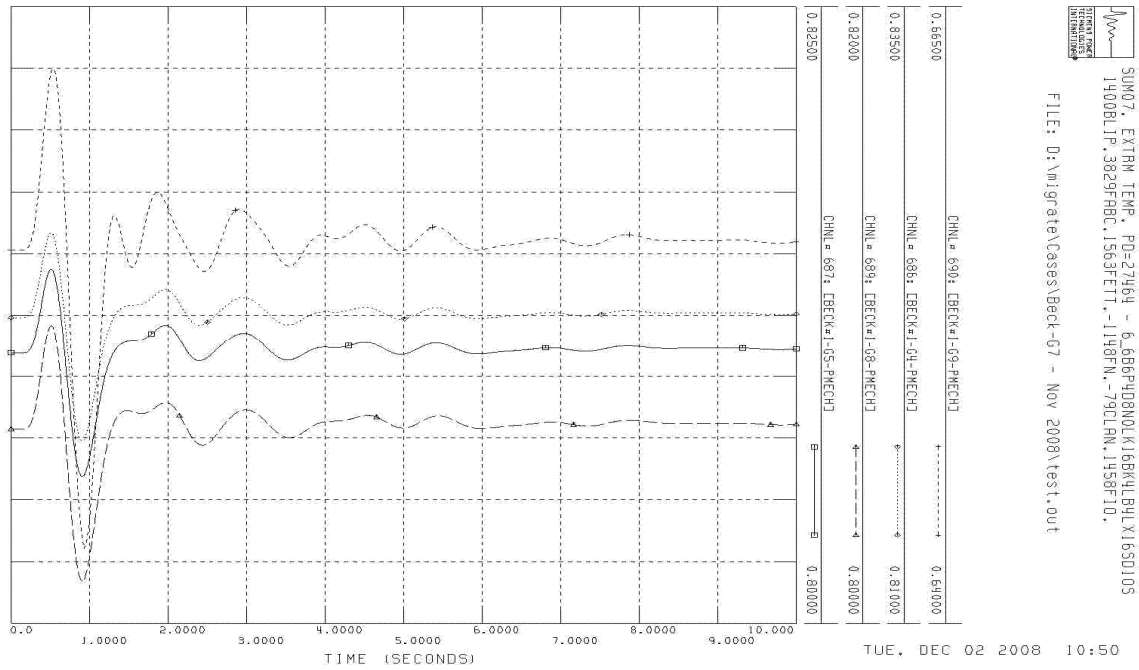

Figure 3: Simulation Results for a fault close to Beck#1 115 kV bus for G5, G8, G4 and G9

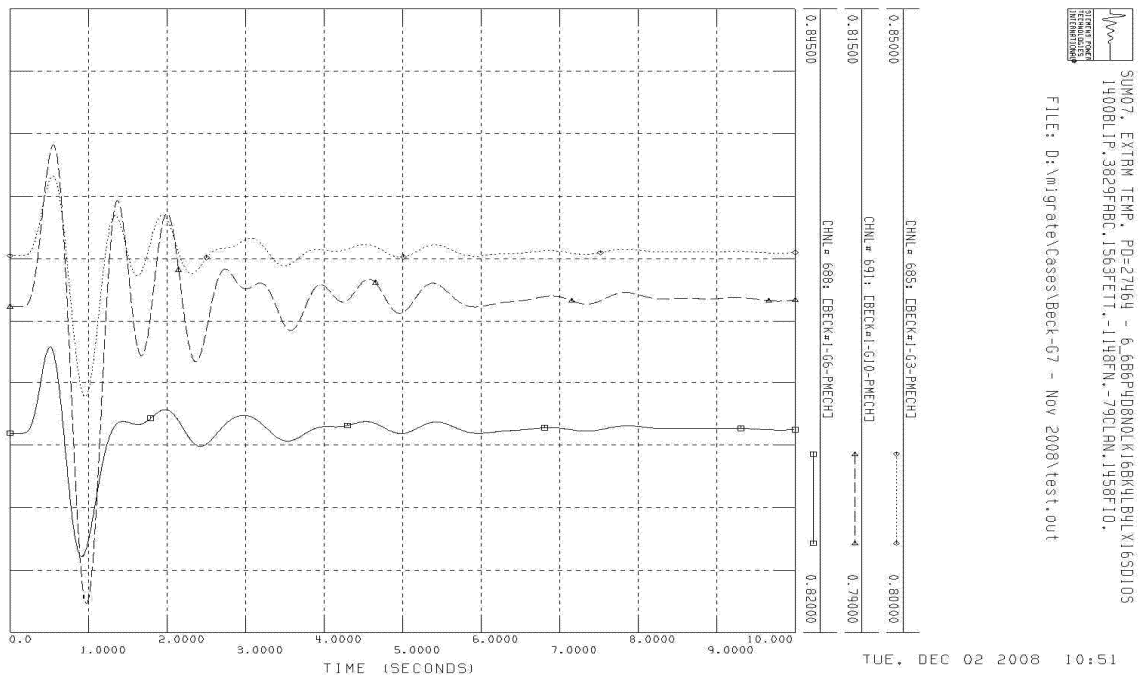

Figure 4: Simulation Results for a fault close to Beck#1 115 kV bus for G6, G10 and G3

The results show that all generators at Beck#1 GS display well damped and stable performance.

It can be concluded that the replacement of the governors do not have a material adverse impact on the dynamic performance of the system and hence on system reliability.

4.0 Conclusions

The proposed governors satisfies the requirements of Market Rules Chapter 4 Appendix 4.2 – Generation Facility Requirements (Embedded and Non-Embedded), Reference 16.

The IESO controlled grid reliability is not materially affected by the replacement of governors at Beck#1 GS.