

LAKE SUPERIOR GS – STG1 AVR UPGRADE IESO EXPEDITED SYSTEM IMPACT ASSESSMENT – 2008-EX396

1. PROJECT DESCRIPTION

Brookfield Power Inc. is proposing to change the static pilot exciter to a modern digital unit implementing a PID AVR control for STG1 at Lake Superior GS.

The scheduled commissioning date for the upgrade is July 21, 2008, and in-service date July 28, 2008.

2. EQUIPMENT DATA VERIFICATION

A. Generator Model

Table 1: Parameters of the Generator Model

GENROU: Round Rotor Generator Model

Description	Cons	Parameter	Value	Units
D-Axis O.C. Transient Time Constant	J	T'do (>0)	4.01	sec
D-Axis O.C. Sub-Transient Time Constant	J+1	T''do (>0)	0.022	sec
Q-Axis O.C. Transient Time Constant	J+2	T'qo (>0)	0.41	sec
Q-Axis O.C. Sub-Transient Time Constant	J+3	T''qo (>0)	0.051	sec
Inertia	J+4	H	4.78	pu
Speed Damping	J+5	D	0	pu
D-Axis Synchronous Reactance	J+6	Xd	1.914	pu
Q-Axis Synchronous Reactance	J+7	Xq	1.78	pu
D-Axis Transient Reactance	J+8	X'd	0.273	pu
Q-Axis Transient Reactance	J+9	X'q	0.476	pu
D-Axis/Q-Axis Sub-Transient Reactance	J+10	X''d = X''q	0.187	pu
Leakage Reactance	J+11	Xl	0.158	pu
Open Circuit Saturation factor	J+12	S(1.0)	0.0811	pu
Open Circuit Saturation factor	J+13	S(1.2)	0.2862	pu

Table 1 shows the parameters of the generator model. The IESO noticed that the saturation factors S(1.0) and S(1.2), provided by the applicant, are different from the data already in the IESO database based on facility registration. New data are used for this assessment.

B. Excitation System with new AVR

The excitation system with the proposed new AVR is an IEEE Type AC7B exciter model. The block diagram of excitation system provided by the connection applicant is shown in Figure 1. The parameters of the exciter are shown in Table 2.

Table 2 Parameters of the Excitation System

Description	CONs	Parameter	Value	Units
Voltage transducer time constant	J	Tr	0.01	sec
AVR proportional gain	J+1	Kpr	64.4	
AVR integral gain	J+2	Kir	64.6	
AVR derivative gain	J+3	Kdr	0	
AVR derivative time constant	J+4	Tdr	0	sec
Maximum output	J+5	Vrmax	999	
Minimum output	J+6	Vrmin	-999	
Proportional gain	J+7	Kpa	1.68	
Integral gain	J+8	Kia	3.03	
Maximum output	J+9	Vamax	1	
Minimum output	J+10	Vamin	-0.8	
Exciter field voltage source gain	J+11	Kp	19.53	
Exciter field voltage lower limit	J+12	Kl	99	
Field voltage feedback gain	J+13	Kf1	0	
Field current feedback gain	J+14	Kf2	1	
Rate feedback gain	J+15	Kf3	0	
Rate feedback time constant	J+16	Tf	0	sec
Rectifier loading factor	J+17	Kc	0.05	
Demagnetization factor	J+18	Kd	2.95	
Exciter constant	J+19	Ke	1	
Exciter field time constant	J+20	Te	0.555	sec
Exciter field maximum output	J+21	Vfemax	26.34	
Exciter field minimum output	J+22	Vemin	0	
Flux at knee of curve	J+23	E1	7	
Saturation factor at knee of curve	J+24	S(E1)	0.07	
Maximum exciter flux	J+25	E2	8	
Saturation factor at max exciter flux	J+26	S(E2)	0.24	

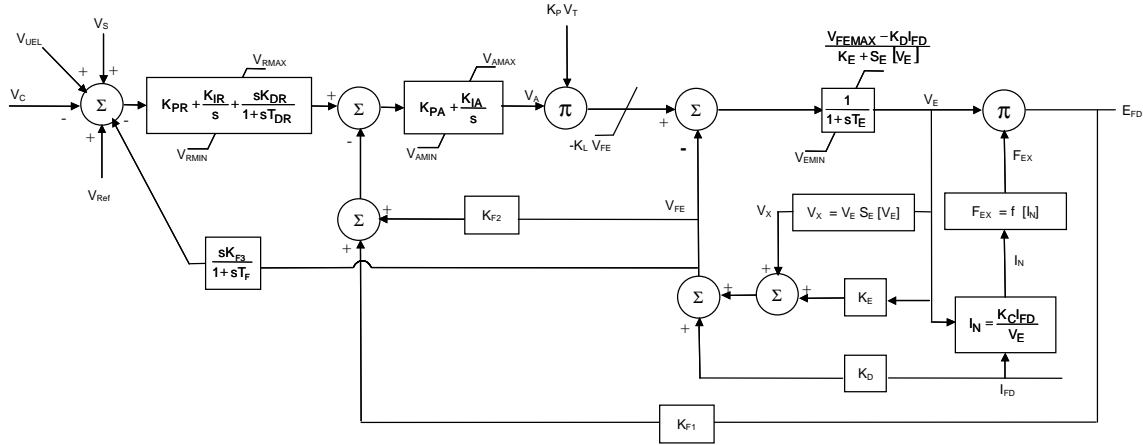

Figure 1 Block Diagram of the Excitation System

C. Power System Stabilizer Model

In accordance with the Market Rules, the generating unit shall be equipped with a power system stabilizer. Brookfield Power Inc. will add a power system stabilizer (PSS) to the unit during the AVR upgrade. The PSS will be IEEE type PSS2A Dual-Input Power System Stabilizer. The block diagram of the PSS provided by the applicant is shown in Figure 2 and the parameters of the PSS are shown in Table 3.

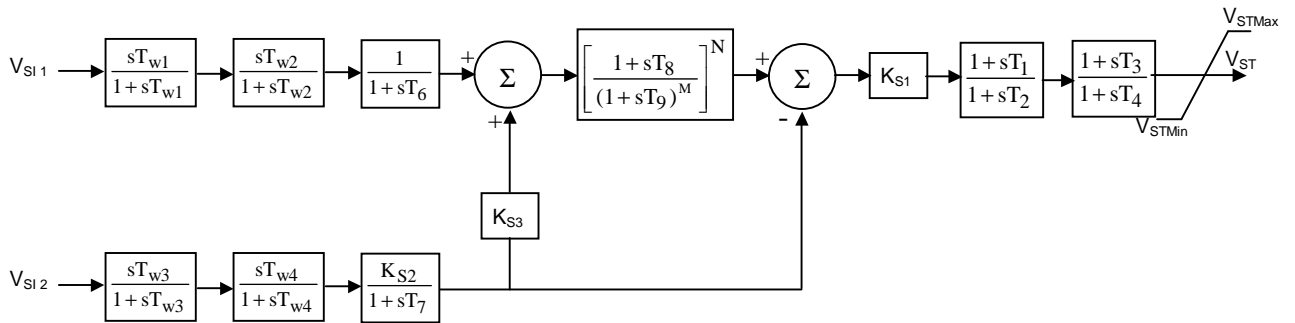

Figure 2 Block Diagram of the PSS

Table 3: Parameters of the PSS

Description	ICONS	Parameter	Value	Units
First stabilizer input code	IC	ICS1	1	Rotor speed deviation (pu)
First remote bus number	IC+1	REMBUS1	0	remote sensing bus (not used)
Second stabilizer input code	IC+2	ICS2	3	Generator electrical power on MBASE base (pu)
Second remote bus number	IC+3	REMBUS2	0	remote sensing bus (not used)
Ramp tracking filter order	IC+4	M	5	
Ramp tracking filter order	IC+5	N	1	

Description	CONS	Parameter	Value	Units
Washout time constant	J	Tw1 (>0)	5	sec
Washout time constant	J+1	Tw2	5	sec
Filter time constant	J+2	T6	0	sec
Washout time constant	J+3	Tw3 (>0)	5	sec
Filter time constant	J+4	Tw4	0	sec
Washout time constant	J+5	T7	5	sec
Gain	J+6	KS2 (= T7/2H)	0.523	
Gain	J+7	KS3	1	
Ramp-tracking filter time constant	J+8	T8	0.5	sec
Ramp-tracking filter time constant	J+9	T9 (>0)	0.1	sec
Stabilizer gain	J+10	KS1	5	
Phase lead time constant	J+11	T1	0.09	sec
Phase lag time constant	J+12	T2	0.02	sec
Phase lead time constant	J+13	T3	0.09	sec
Phase lag time constant	J+14	T4	0.02	sec
Output limits	J+15	VSTMAX	0.05	pu E _{ref}
Output limits	J+16	VSTMIN	-0.05	pu E _{ref}
Generator Apparent Power		MBASE	30.7	MVA
Turbine Generator Inertia		H	4.78	MW-s/MVA

As soon as the commissioning tests are completed and actual data is available, the connection applicant is required to provide an updated block diagram model and data of the excitation system. If the models and data differ materially from those used in the studies, the IESO may be performing additional studies to verify the behavior of the excitation system and establish the need for any new controls and adjustments, as part of the Facility Registration Process.

3. ASSESSMENTS OF NEW EXCITATION SYSTEM

The following requirements for exciters on generation unit rated at 10 MVA or higher are listed in Reference 12 of Appendix 4.2 in Market Rules:

- A voltage response time not longer than 50 ms for a voltage reference step change not to exceed 5%;
- A positive ceiling voltage of at least 200% of the rated field voltage, and
- A negative ceiling voltage of at least 140% of the rated field voltage.

Since only AVR is upgraded in this project, the new AVR will be acceptable if

- Performance of the excitation system with new AVR meets the Market Rules, or
- Performance of the excitation system with new AVR is not worse than that of the excitation with old AVR in terms of response time and ceiling voltage.

To perform a fair comparison between the old and new excitation systems, several parameters of the EXAC2 model representing the old excitation system are corrected based on the new exciter parameters provided by the applicant. These parameters relate to the main exciter and the permanent magnet generator (PMG) power source, which will not be changed in this project. The affected parameters are shown in Table 4.

Table 4 Corrected Parameters of the EXAC2 Model Representing the Old Excitation System

	Old Value	New Value
V _{rmax}	25.4	19.53
K _c	0	0.05
K _d	0	2.95
E1	2.98	7
S(E1)	2.98	0.07
E2	3.98	8
S(E2)	3.16	0.24

In addition, the requirements for power system stabilizers (PSS) are described in Reference 15 of Appendix 4.2:

- Each synchronous generating unit that is equipped with an excitation system that meets the performance requirements shall also be equipped with a power system stabilizer. The power system stabilizer shall, to the extent practicable, be tuned to increase damping torque without reducing synchronizing torque.

In this assessment dynamic simulations are performed to verify if the transient response of the new excitation systems meets the above requirements and investigate transient stability under system contingencies.

3.1 Open Circuit Test

The results of the exciter system voltage response test to a 5% step change in reference voltage are displayed in Figure 3. The terminal voltage response time based on the new exciter is about 101 ms, which is much faster than the old exciter (679 ms). The new exciter performance is better than the old exciter, thus meeting the above-mentioned requirements.

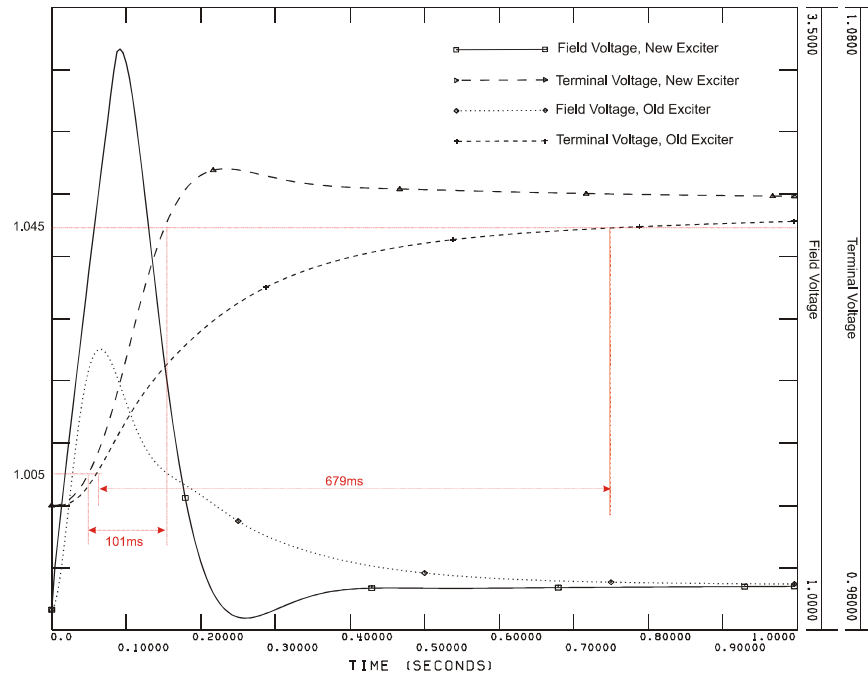

Figure 3 Open Circuit Test Results

3.2 Response Ratio Test

Response ratio tests are conducted to evaluate the positive ceiling voltage for the excitation system. Each generator is initialized to its rated MVA at a 95% lagging power factor. At $t=0$, the voltage set point is raised suddenly to drive to the exciter's ceiling voltage as quickly as possible.

Figure 4 shows that the exciter rated field voltage is about 2.56 pu. The ceiling voltage of the new exciter is about 6.82 pu, which is more than twice the rated field voltage. Figure 4 indicates that the new exciter has a better performance than the old one.

The results of the excitation system response ratio test indicate that the exciter ceiling voltage meets the requirement of the Market Rules.

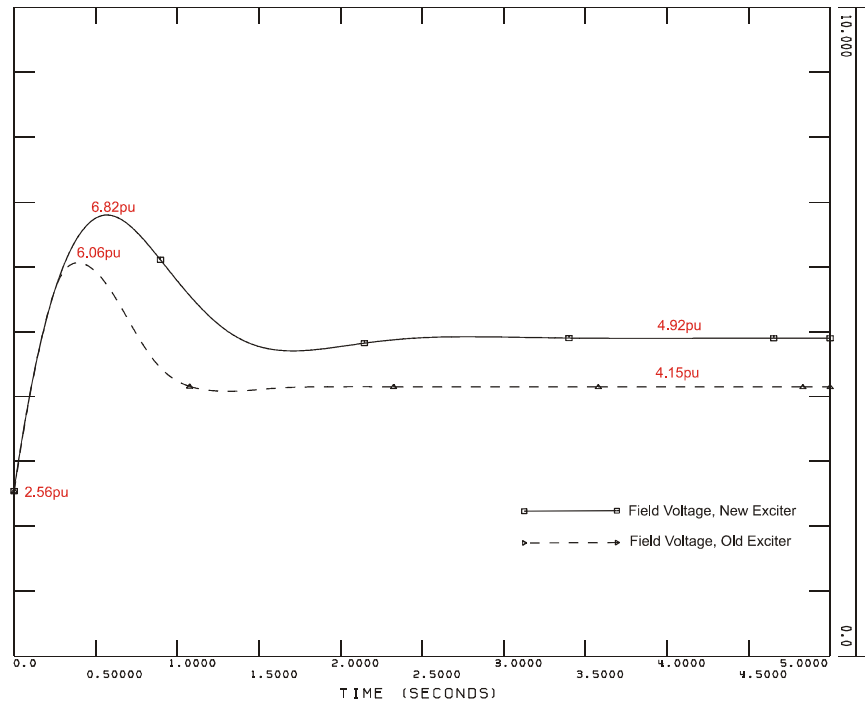

Figure 4 Response Ratio Test Results

3.3 Transient Stability Test

The transient stability analysis was performed for a LLG fault on 115 kV circuit Clergue #2, from Steelton TS to Clergue GS, with normal clearing time. The generating unit field voltages, rotor angles, terminal voltages, and power outputs of GTG1/GTG2 and STG1 at Lake Superior GS are investigated.

Figures 5(A) and 5(B) show the rotor angles of STG1 and GTG1 at Lake Superior GS. Figure 5(A) indicates that the damping of STG1 rotor angle is a bit worse for the new exciter without PSS as compared with the old exciter. However, the PSS contributes a positive damping on the rotor angle during the transient, eliminating the small adverse impact mentioned above. Figure 5(B) shows that the AVR upgrade of STG1 has insignificant impact on the dynamics of GTG1. Both generating units display stable performance for the defined fault. Thus, the excitation systems with new AVR do not have material adverse impact on the system dynamic performance and the PSS performance is also acceptable.

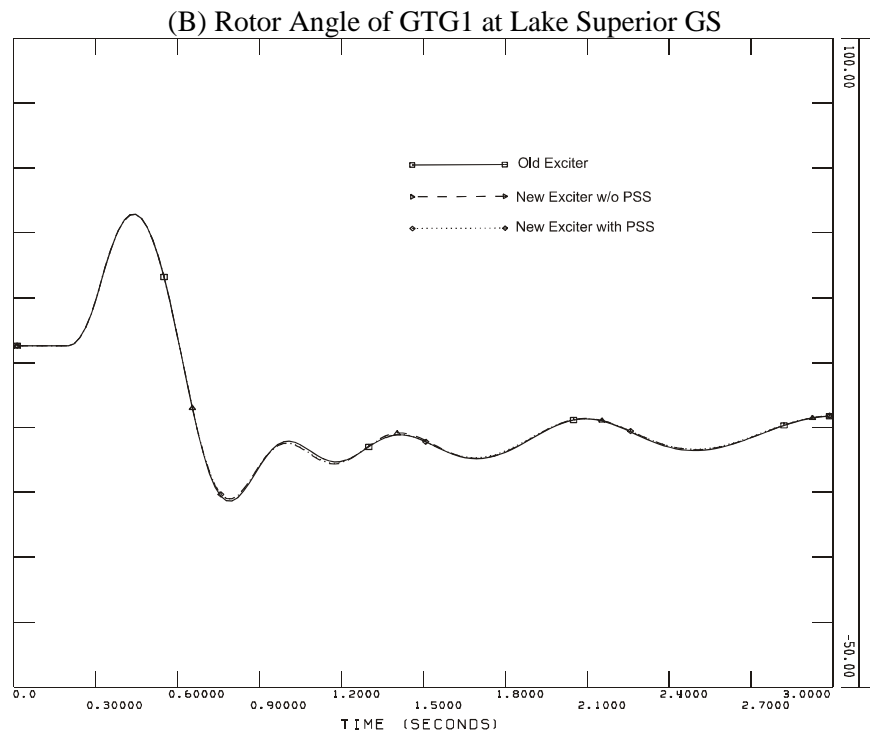
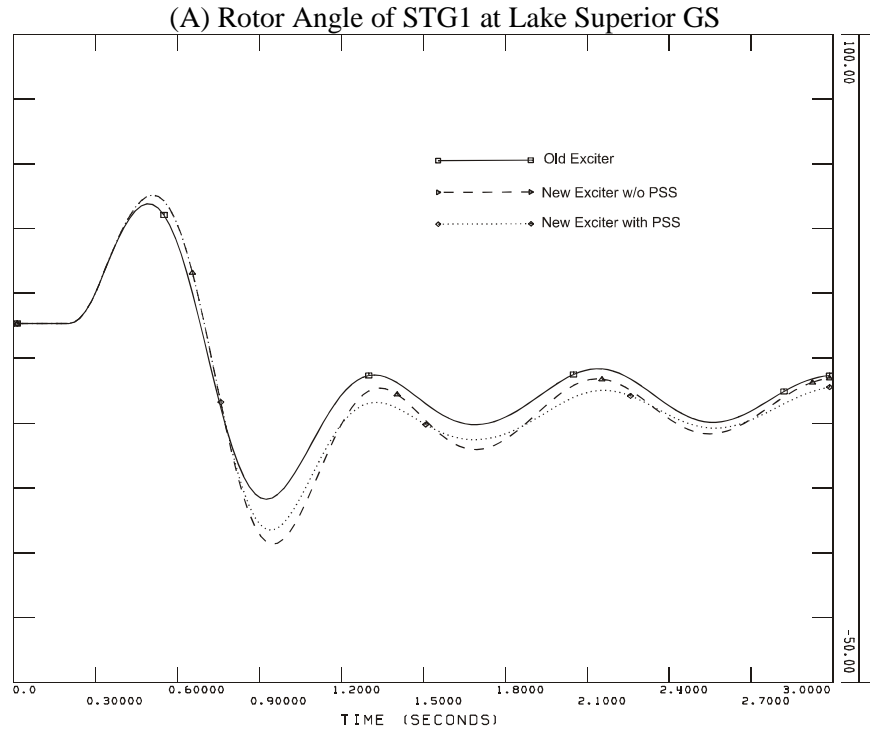

Figure 5 Simulation Results for a LLG Fault

4. CONCLUSIONS AND REQUIREMENTS

The IESO has concluded that the proposed AVR upgrade will not have a negative effect on the reliability of the IESO-controlled grid.

The applicant is required to ensure that the performance of the equipment that is eventually supplied and installed on the unit STG1 at Lake Superior GS is similar to the predicted performance or exceeds the predicted performance observed in the simulation results obtained using the above models.

As soon as the commissioning tests are completed and actual data is available, the connection applicant is required to provide updated parameters and models for STG1. Using these data the IESO will verify the tested results and establish the need for any new controls and adjustments, as part of the Facility Registration process. If the actual data differ materially from the data that was used in the assessment, the analysis will need to be repeated.

Since some parameters of the generator STG1, provided by the applicant in this project, are different from the IESO database, the applicant should also update the generator data and model with the IESO during the Facility Registration process.

5. NOTIFICATION OF APPROVAL

It is therefore recommended that a Notification of Conditional Approval of the Connection Proposal be issued to the applicant, subject to the requirements detailed above.